

**MINI**  **TECNO**™  
**small** but strong

**Ott** Antriebstechnik  
Standardisierte Individualität

**AC - Getriebemotoren**  
**AC - Bremsmotoren**  
**AC - UL-Motoren**



















**MINI**  **TECNO**™ brand of  
**TRANSTECNO**®



AC



	Indice	Index	Pag. Page
 	<b>A-A</b> Motori elettrici CA SM	AC Electric motors SM	A-A1
	<b>A-B</b> Motori elettrici CA autofrenanti SM..BR	Braked AC Electric motors SM..BR	A-A1
	<b>A-C</b> Motori elettrici CA servoventilati SM..SV	AC Electric Motors with forced-ventilation SM..SV	A-A1
	<b>A-D</b> Motori elettrici CA SM..UL	AC Electric motors SM..UL	A-A1
 	<b>A-E</b> Motoriduttori CA ad ingranaggi cilindrici CMG	AC Helical in-line garmotors CMG	A-B1
 	<b>A-F</b> Motoriduttori CA ad assi ortogonali CMB	AC Helical bevel garmotors CMB	A-C1
 	<b>A-G</b> Motoriduttori CA pendolari KFT105 - FT	AC Helical parallel garmotors KFT105 - FT	A-D1
	<b>A-H</b> Motoriduttori CA a vite senza fine CM/CMP	AC Wormgarmotors CM/CMP	A-E1
	<b>A-I</b> Motoriduttori CA combinati a vite senza fine CMM	AC Doble reduction wormgarmotors CMM	A-F1
 	<b>A-L</b> Motoriduttori CA epicicloidali P	AC Planetary garmotors P	A-G1
	<b>A-M</b> Motoriduttori CA combinati WMP	AC Doble reduction garmotors WMP	A-H1

Questo catalogo annulla e sostituisce ogni precedente edizione o revisione.  
Ci riserviamo inoltre il diritto di apportare modifiche senza preavviso.  
La versione più aggiornata è disponibile sul sito  
[www.transtecno.com](http://www.transtecno.com)

*This catalogue supersedes any previous edition and revision.  
We reserve the right to implement modifications without notice.  
The most updated version is available on our website  
[www.transtecno.com](http://www.transtecno.com)*



**MINI**  **TECNO**™  
**small** but strong

**SM**



AC

**Motori elettrici asincroni CA**  
**AC asynchronous electric motors**



**MINI**  **TECNO**™ brand of  
**TRANSTECNO**®





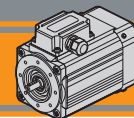

<b>Indice</b>	<b>Index</b>	Pag. Page
Caratteristiche tecniche	<i>Technical features</i>	<b>AA2</b>
Designazione	<i>Classification</i>	<b>AA3</b>
Simbologia e formule	<i>Symbols and formulas</i>	<b>AA3</b>
Dati tecnici motori trifase	<i>Three phase motors technical data</i>	<b>AA4</b>
Dati tecnici motori monofase	<i>Single phase motors technical data</i>	<b>AA5</b>
Dimensioni motori trifase	<i>Three phase motors dimensions</i>	<b>AA6</b>
Dimensioni motori monofase	<i>Single phase motors dimensions</i>	<b>AA8</b>
Cava esagonale	<i>Hexagonal socket</i>	<b>AA10</b>
Opzione guarnizione CA	<i>Rubber gasket option</i>	<b>AA10</b>
Gradi di protezione IP	<i>IP protection rating</i>	<b>AA11</b>
Normative di riferimento	<i>Reference standards</i>	<b>AA11</b>
Tipo di servizio IEC	<i>IEC duty cycles</i>	<b>AA12</b>
Classe di isolamento termico	<i>Insulation class</i>	<b>AA12</b>
Serie SM - Funzionamento a 60 Hz	<i>Series SM - 60 Hz line power supply</i>	<b>AA13</b>
Tabella pressacavi	<i>Table of cable glands data</i>	<b>AA13</b>
Connessioni e collegamenti	<i>Connection diagram</i>	<b>AA13</b>
Targhetta	<i>Nameplate</i>	<b>AA18</b>

Questa sezione annulla e sostituisce ogni precedente edizione o revisione. Qualora questa sezione non Vi sia giunta in distribuzione controllata, l'aggiornamento dei dati ivi contenuto non è assicurato. **In tal caso la versione più aggiornata è disponibile sul nostro sito internet [www.transtecno.com](http://www.transtecno.com)**

*This section replaces any previous edition and revision. If you obtained this catalogue other than through controlled distribution channels, the most up to date content is not guaranteed. In this case the latest version is available on our web site [www.transtecno.com](http://www.transtecno.com)*

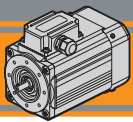

## Caratteristiche tecniche

## Technical characteristics

I motori delle serie SMT ed SMM hanno le seguenti caratteristiche principali:

*SMT and SMM motor range has the following main features:*

- Costruzione compatta
  - Motorizzazioni in corrente alternata monofase e trifase
  - Carcassa estrusa in alluminio anodizzato nero
  - Motore elettrico AC con grado di protezione IP66 eccetto il condensatore.
  - Rumorosità e vibrazioni contenute
  - Isolamento termico di classe F
  - Flangia motore IEC B14
  - Temperatura ambiente: -20°C / +40°C
  - Disponibili sia nella versione ventilata TEFC (servizio S1) che non ventilata TENV (servizio S3)
  - Protezione termica PTO 150°C per le taglie 56, 63 e 71.
  - SMT56, SMT63 e SMT71 adatti al funzionamento con alimentazione da inverter.
  - Cava esagonale su albero motore lato NDE.
  - Condensatore di marcia sempre cablato ad esclusione della taglia SMM50.
  - La tolleranza di tensione è  $\pm 10\%$  per tutti i motori ad esclusione della taglia 50 ( $\pm 5\%$ ).
  - Disponibili nelle versioni autofrenante, servoventilata e con certificazione UL.
- *Compact design*
  - *AC single phase and three phase motors available*
  - *Black anodized extruded aluminium housing*
  - *AC electric motor in IP66 protection Standard, except capacitor*
  - *Low noise and vibrations*
  - *Class F insulation Standard*
  - *Motor flange IEC B14*
  - *Ambient temperature: -20°C / +40°C*
  - *Fan cooled TEFC (duty S1) and not ventilated TENV (duty S3) versions available*
  - *PTO 150°C thermal protection for motor sizes 56, 63 and 71.*
  - *SMT56, SMT63 and SMT71 are suitable for inverter duty.*
  - *Motor shaft hexagon socket on the NDE side.*
  - *Running capacitor always connected, except for SMM50.*
  - *The voltage tolerance is  $\pm 10\%$  for all motors, except for size 50 ( $\pm 5\%$ ).*
  - *Brake motors, forced ventilation motors and UL compliance versions available.*

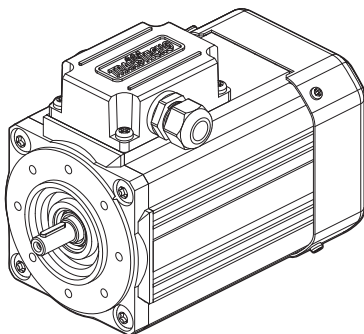

**SM .. TEFC**

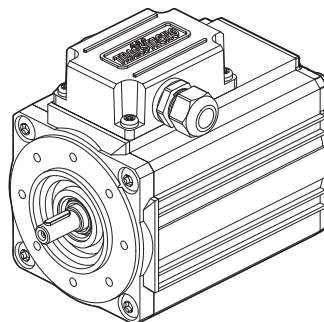

**SM .. TENV**



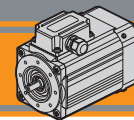

**Designazione**
**Classification**

MOTORE TRIFASE / THREE PHASE MOTOR									
SMT	63	2	4	0.18 kW	B14	230-400 V	50 Hz	TEFC	BR
Tipo Type	Grandezza Size	Indicativo potenza Power coefficient	Poli Poles	Potenza Power	Forma costruttiva Version	Tensione Voltage	Frequenza Frequency	Ventilazione Fan cooling	Opzioni Options
SMT  	Vedi tabelle See tables	1-2-3-4-5	4	0.04 kW ... 0.75 kW	B14	230-400 V  460V	50Hz  60Hz	TEFC  TENV	BR →  SV →  UL-CSA →

MOTORE MONOFASE / SINGLE PHASE MOTOR									
SMM	63	2	4	0.18 kW	B14	230 V	50 Hz	TEFC	-
Tipo Type	Grandezza Size	Indicativo potenza Power coefficient	Poli Poles	Potenza Power	Forma costruttiva Version	Tensione Voltage	Frequenza Frequency	Ventilazione Fan cooling	Opzioni Options
SMM  	Vedi tabelle See tables	1-2-3-4	4	0.04 kW ... 0.55 kW	B14	230V  115V (UL-CSA)	50Hz	TEFC  TENV	UL-CSA →

**Simbologia e formule**
**Symbols and formulas**

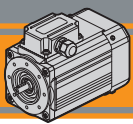
$P_n$	[kW]	Potenza nominale	<i>Rated power</i>
$I_n$	[A]	Corrente nominale (a 400V)	<i>Rated current (at 400V)</i>
$M_n$	[Nm]	Coppia nominale	<i>Rated torque</i>
$n_n$	[rpm]	Velocità nominale	<i>Rated speed</i>
$M_s / M_n$		Rapporto coppia spunto / coppia nominale	<i>Ratio start torque / rated torque</i>
$M_k / M_n$		Rapporto coppia massima / coppia nominale	<i>Ratio max torque / rated torque</i>
$I_s / I_n$		Rapporto corrente di spunto / corrente nominale	<i>Ratio start current / rated current</i>
$\cos\varphi$		Fattore di potenza al carico nominale	<i>Power factor at rated torque load</i>
$\eta$		Rendimento al carico nominale	<i>Efficiency at rated torque load</i>
Potenza Power	[HP]	Potenza [kW] x 1.341	<i>Power [kW] x 1.341</i>
Potenza resa $P_n$ $P_n$ output power	[kW]	Potenza assorbita x $\eta$	<i>Absorbed power x <math>\eta</math></i>
Pot. assorbita Absorbed power	[kW]	$\frac{\sqrt{x} \cdot I \cdot \cos\varphi}{1000}$ (monofase)	$\frac{\sqrt{x} \cdot I \cdot \cos\varphi}{1000}$ (singlephase)
		$\frac{\sqrt{x} \cdot I \cdot \sqrt{3} \cdot \cos\varphi}{1000}$ (trifase)	$\frac{\sqrt{x} \cdot I \cdot \sqrt{3} \cdot \cos\varphi}{1000}$ (threephase)
$I_n$ (230 V)		$I_n$ (400 V) x $\sqrt{3}$	$I_n$ (400 V) x $\sqrt{3}$



**Dati tecnici motori trifase**

**Three phase motors technical data**

**SMT** Motori trifase / **SMT** Three phase motors

(230-400 V / 50 Hz) poli / poles **4**

	TAGLIA SIZE	P <sub>n</sub> [kW]	M <sub>n</sub> [Nm]	n <sub>n</sub> [min <sup>-1</sup> ]	I <sub>n</sub> (400V) [A]	η %	cosφ	M <sub>s</sub> /M <sub>n</sub>	I <sub>s</sub> /I <sub>n</sub>	M <sub>k</sub> /M <sub>n</sub>	PTO [°C]	Servizio Duty TEFC	Servizio Duty TENV
	5014	0.04	0.30	1290	0.25	34.0	0.68	1.65	1.75	1.70	-	S1	S3 30%
	5024	0.06	0.44	1300	0.35	35.7	0.69	1.55	1.80	1.60			
	5034	0.09	0.65	1315	0.54	38.0	0.64	1.80	2.00	1.85			
	5044	0.12	0.87	1315	0.64	43.0	0.63	1.80	2.00	1.80		S3 75%	
	5624	0.09	0.64	1345	0.45	46.5	0.62	2.50	2.40	2.70	PTO 150°	S1	S3 50%
	5634	0.12	0.89	1300	0.45	52.0	0.74	1.90	2.40	1.90		S3 75%	
<b>IE2</b>	5634 IE2	0.12	0.84	1360	0.48	59.1	0.61	2.70	2.90	2.70		S1	-
	5644	0.18	1.26	1360	0.69	59.0	0.65	2.50	3.00	2.60		S3 75%	S3 50%
	5654	0.25	1.80	1330	0.93	59.0	0.66	2.50	2.80	2.60			
	6324	0.18	1.26	1360	0.69	57.0	0.66	2.50	2.90	2.50		S1	-
<b>IE2</b>	6324 IE2	0.18	1.27	1360	0.65	64.7	0.62	2.50	2.90	2.50			
	6334	0.25	1.74	1375	0.94	62.0	0.64	2.80	3.00	2.80		S3 75%	S3 50%
<b>IE2</b>	6334 IE2	0.25	1.72	1390	0.88	68.5	0.60	3.20	3.50	3.20		S1	-
	6344	0.37	2.60	1360	1.24	65.3	0.66	2.70	3.00	2.70		S3 75%	S3 50% S3 45%
	7124	0.37	2.52	1400	1.10	67.9	0.72	2.75	4.20	2.75			
<b>IE2</b>	7124 IE2	0.37	2.48	1425	1.05	72.7	0.70	2.80	4.90	2.90		S1	-
	7134	0.55	3.76	1395	1.55	70.2	0.73	2.90	4.40	2.90		S3 75%	S3 45%
<b>IE2</b>	7134 IE2	0.55	3.70	1420	1.56	77.1	0.66	3.40	5.20	3.40			
	7144	0.75	5.09	1405	2.00	74.0	0.73	2.90	5.00	2.90		S3 75%	S3 45%
<b>IE3</b>	8024 IE3	0.75	4.96	1440	1.94	82.5	0.68	3.60	6.00	3.70		S1	S3 70% S3 75%
	8034 IE3	1.1	7.25	1450	2.91	84.1	0.65	4.00	6.80	4.40			
	9024 IE3	1.5	10.0	1430	3.48	85.3	0.73	3.20	6.30	3.50			
	9034 IE3	2.2	14.9	1410	4.68	86.7	0.79	3.00	6.20	3.30			

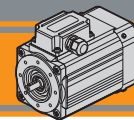
**Dati tecnici motori monofase**
**Single phase motors technical data**
**SMM Motori monofase / SMM Single phase motors**

 (230 V / 50 Hz) poli / poles **4**

TAGLIA SIZE	P <sub>n</sub> [kW]	M <sub>n</sub> [Nm]	n <sub>n</sub> [min <sup>-1</sup> ]	I <sub>n</sub> (230V) [A]	η %	cosφ	M <sub>s</sub> /M <sub>n</sub>	I <sub>s</sub> /I <sub>n</sub>	M <sub>k</sub> /M <sub>n</sub>	Cond/cap [μF]	PTO [°C]	Servizio Duty TEFC	Servizio Duty TENV
5014	0.04	0.27	1390	0.60	33.4	0.88	0.74	1.60	1.55	8.0	-	S1	S3 30%
5024	0.06	0.42	1380	0.89	34.3	0.85	0.76	1.70	1.50	12.0			
5034	0.09	0.63	1375	1.10	40.0	0.89	0.80	1.70	1.45	16.0	PTO 150°	S3 75%	S3 50%
5624	0.09	0.63	1370	0.82	48.6	0.98	0.72	1.70	1.45	6.3			
5634	0.12	0.83	1380	1.06	50.3	0.98	0.75	2.10	1.65	9.0			
5644	0.18	1.25	1375	1.50	53.8	0.97	0.70	2.20	1.58	12.5			
6324	0.18	1.33	1290	1.50	54.5	0.97	1.00	1.80	1.45	12.0			
6334	0.25	1.85	1290	1.95	56.8	0.98	0.93	1.90	1.50	16.0			
7124	0.37	2.72	1300	2.78	58.6	0.99	0.77	2.00	1.35	20.0			
7134	0.55	3.95	1330	3.54	68.9	0.98	0.66	2.40	1.40	25.0			
8024	0.75	5.31	1350	4.93	67.4	0.98	0.67	2.50	1.54	35.0		S3 45%	
													S3 40%

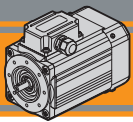

Dimensioni motori trifase

Three phase motors dimensions

3~

**SMT50.. - B14 - TEFC / TENV**

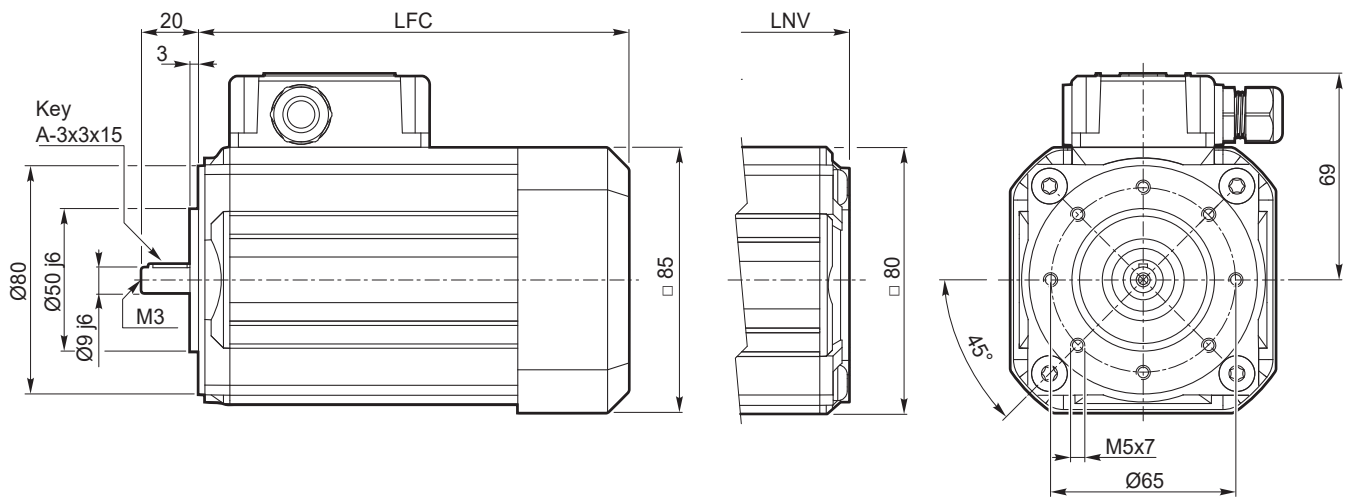

SMT	... TEFC		... TENV	
	LFC	kg	LNV	kg
5014	135.5	2.3	108.5	2.2
5024	150.5	2.7	123.5	2.6
5034	175.5	3.5	148.5	3.4
5044	200.5	4.2	173.5	4.1

3~

**SMT56.. - B14 - TEFC / TENV**

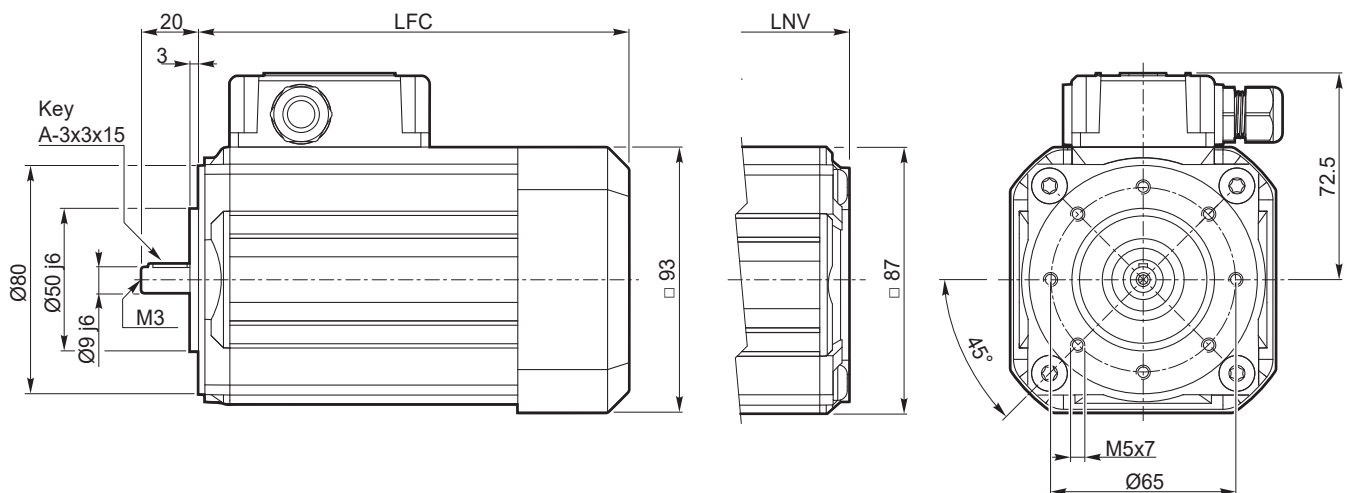

SMT	... TEFC		... TENV	
	LFC	kg	LNV	kg
5624	141	2.9	117	2.8
5634	151	3.2	127	3.1
5634 IE2	171	3.8	-	-
5644	186	4.4	162	4.3
5654	206	5.1	182	5.0

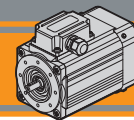

## Dimensioni motori trifase

## Three phase motors dimensions

3~

## SMT63.. - B14 - TEFC / TENV

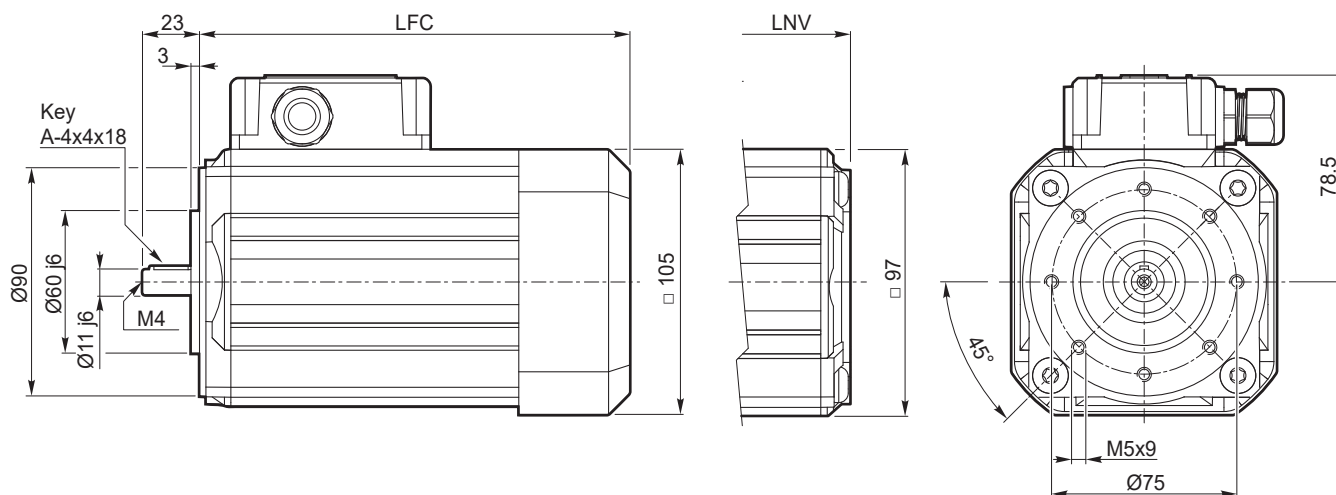

SMT	... TEFC		... TENV	
	LFC	Kg	LNV	Kg
6324	165.5	4.3	138.5	4.2
6324 IE2	180.5	4.9	-	-
6334	180.5	5.0	153.5	4.9
6334 IE2	205.5	6.1	-	-
6344	205.5	6.2	178.5	6.1

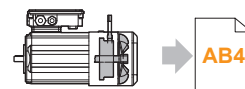
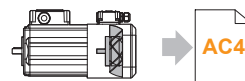

 SM.BR..  
 Motori autofrenanti  
 Brake motors

 SM.V..  
 Motori servoventilati  
 Motors with forced-ventilation

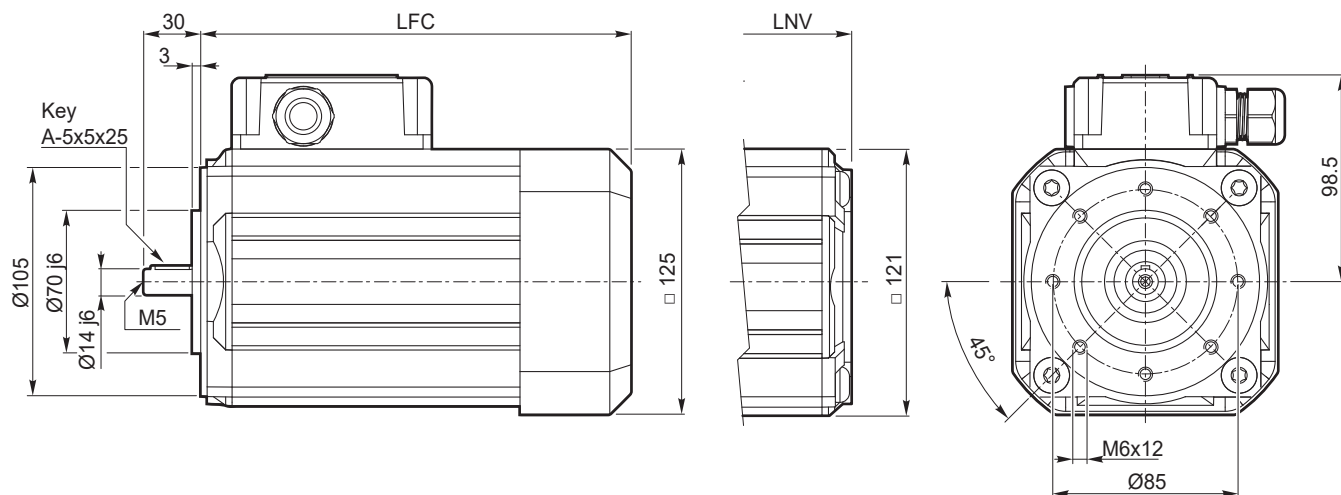
3~

## SMT71.. - B14 - TEFC / TENV

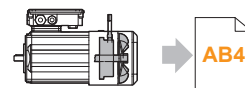
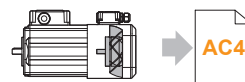

SMT	... TEFC		... TENV	
	LFC	Kg	LNV	Kg
7124	174	6.6	145.5	6.4
7124 IE2	189	7.5	-	-
7134	189	7.7	160.5	7.5
7134 IE2	214	9.2	-	-
7144	214	9.4	185.5	9.2

 SM.BR..  
 Motori autofrenanti  
 Brake motors

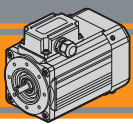
 SM.V..  
 Motori servoventilati  
 Motors with forced-ventilation



Dimensioni motori monofase

Single phase motors dimensions

1~

**SMM50.. - B14 - TEFC / TENV**

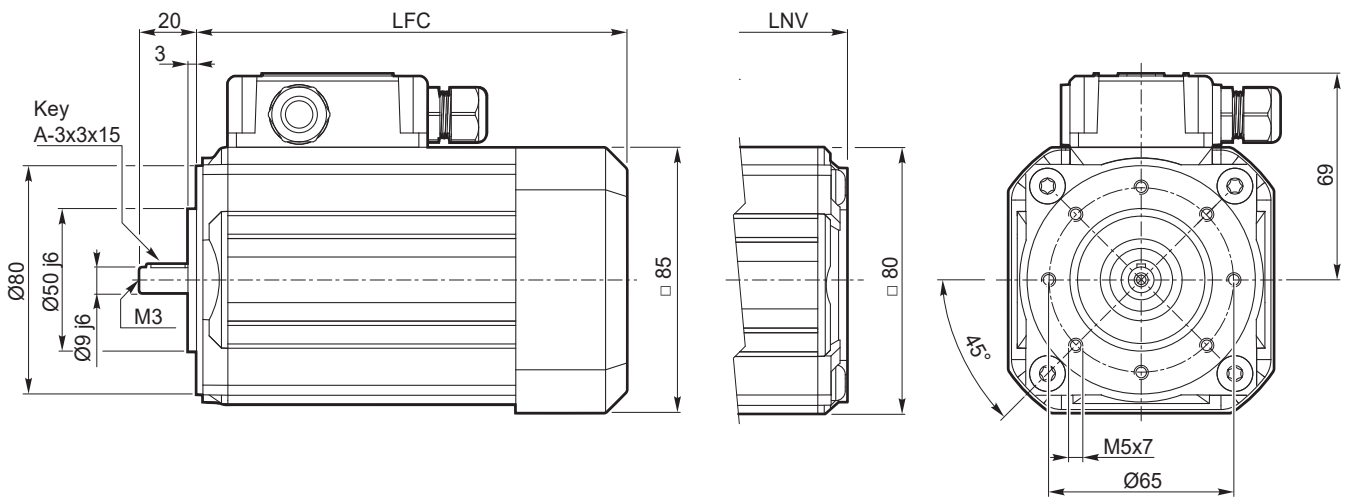

SMM	... TEFC		... TENV	
	LFC	kg	LNV	kg
5014	150.5	2.7	123.5	2.6
5024	175.5	3.5	148.5	3.4
5034	200.5	4.2	173.5	4.1

**Nota:**  
il condensatore sarà fornito a corredo

**Note:**  
the capacitor will be supplied separately

1~

**SMM56.. - B14 - TEFC / TENV**

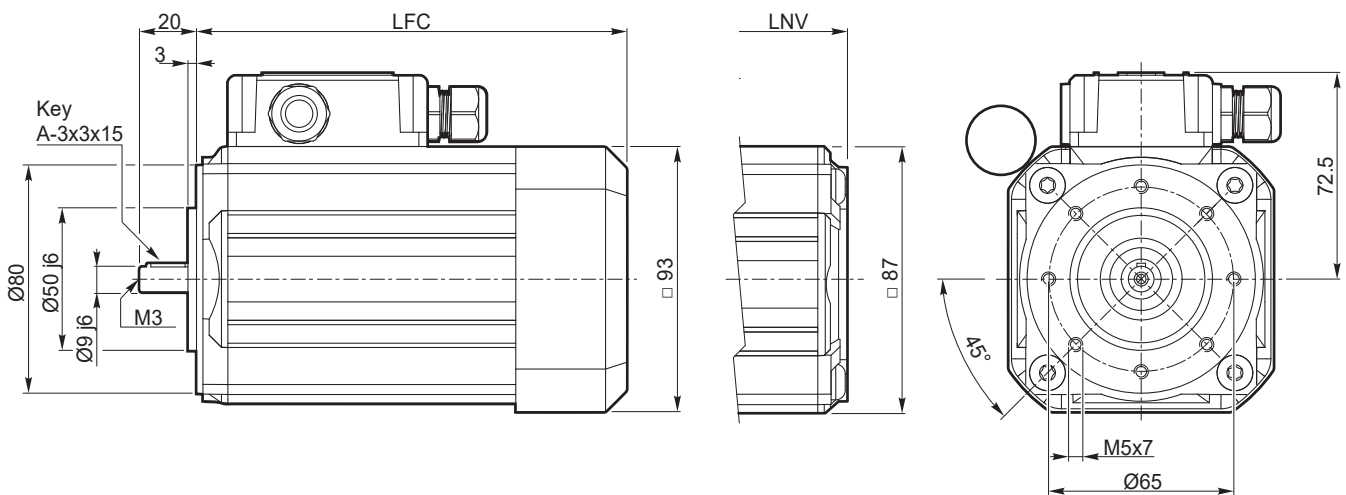

SMM	... TEFC		... TENV	
	LFC	kg	LNV	kg
5624	151	3.3	127	3.2
5634	171	3.9	147	3.8
5644	206	5.0	182	4.9

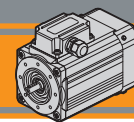

Dimensioni motori monofase

Single phase motors dimensions

1 ~

**SMM63.. - B14 - TEFC / TENV**

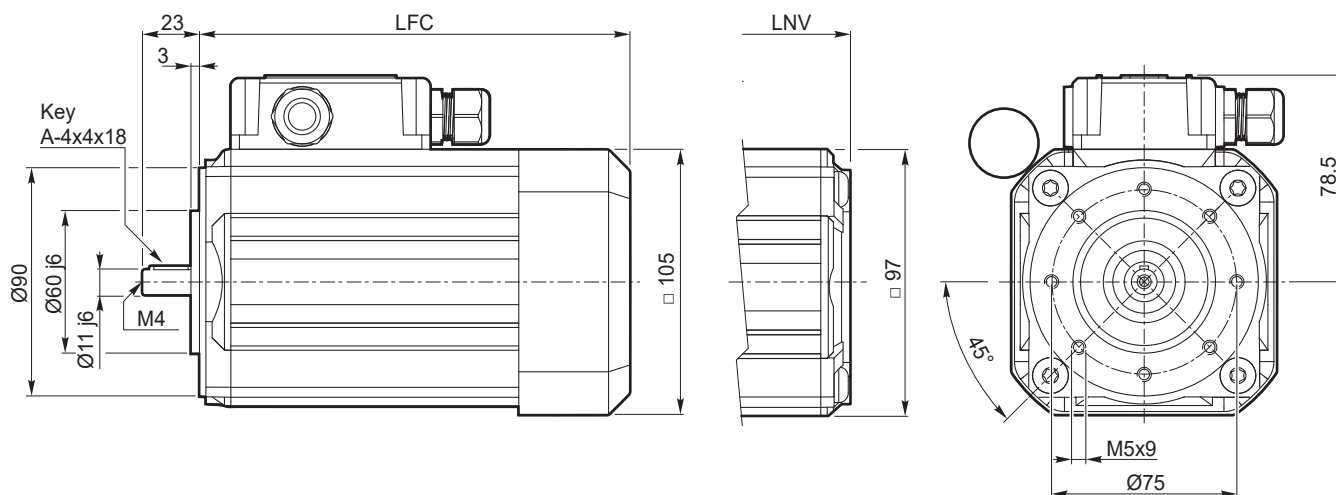

SMM	... TEFC		... TENV	
	LFC	kg	LNV	kg
6324	180.5	5.1	153.5	5.0
6334	205.5	6.2	178.5	6.1

1 ~

**SMM71.. - B14 - TEFC / TENV**

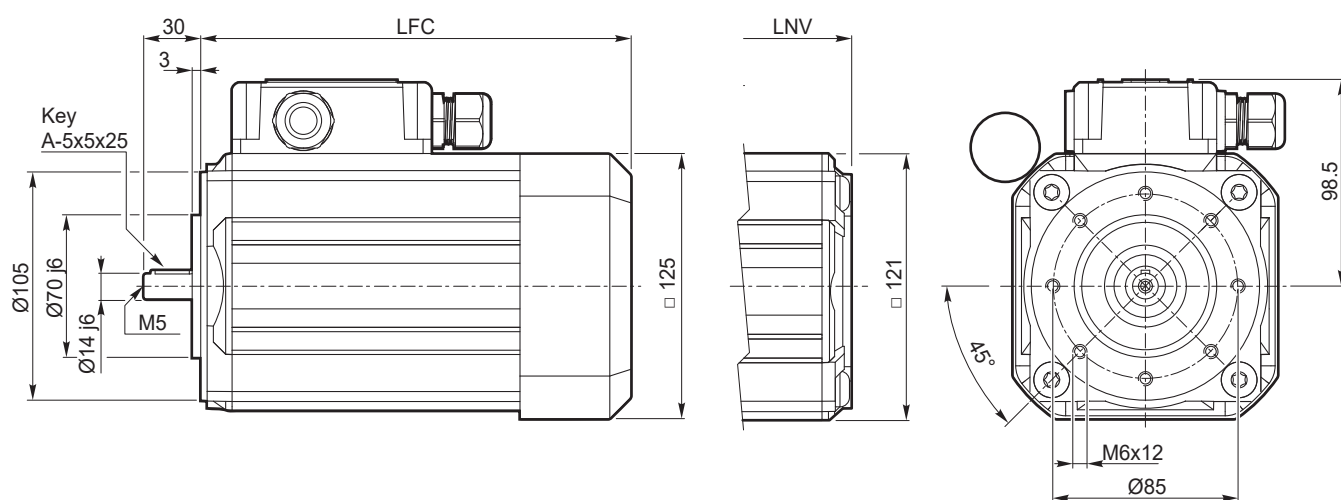

SMM	... TEFC		... TENV	
	LFC	kg	LNV	kg
7124	189	7.3	160.5	7.1
7134	214	9.2	185.5	9.0

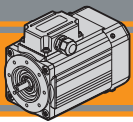

**Cava esagonale**

**Hexagonal socket**

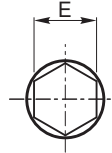
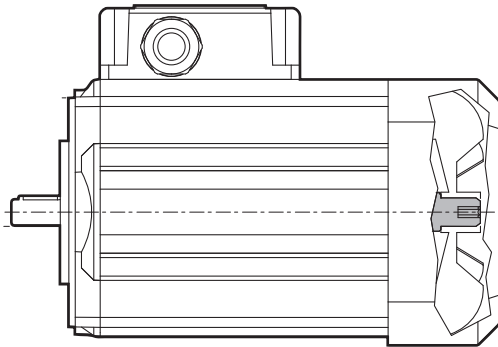

Esagono / Hexagon

SM..	E
50	
56	4
63	
71	6

**Nota:**

Installare a monte dell'alimentazione un dispositivo che assicuri la disconnessione della rete omipolare, durante le operazioni di rotazione manuale è obbligatorio l'utilizzo di tale sezionatore.

Il quadro elettrico del motore deve essere lucchettabile al fine di evitare il riarmo non previsto alla rete elettrica.

E' severamente vietata la messa in servizio del motore elettrico senza copriventola opportunamente montata.

**Note:**

*An omnipolar cut-off device must be fitted upstream of the power supply; the use of this device is mandatory during manual rotation operations.*

*The switchgear for the motor must be padlockable in order to prevent the power supply from being accidentally reset. It is strictly prohibited to put the electric motor into service if the fan cover is not fitted.*

**Opzione guarnizione CA**

**Rubber gasket option**

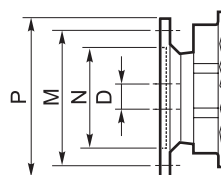
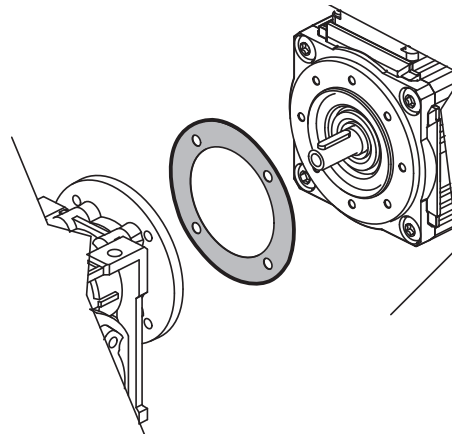

Dimensioni IEC / IEC Dimensions			
	56 B14	63 B14	71 B14
<b>N</b>	50	60	70
<b>M</b>	65	75	85
<b>P</b>	80	90	105
<b>D</b>	9	11	14

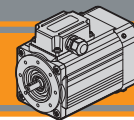
**Grado di protezione IP**
**IP protection rating**

Indica il grado di isolamento meccanico del corpo motore.















1ª cifra protezione alla penetrazione di corpi solidi.

2ª cifra protezione contro la penetrazione d'acqua.

IP protection rating indicates the degree of mechanical insulation of the motor casing.

 The 1<sup>st</sup> figure indicates the level of protection against the intrusion of solid matter.

 The 2<sup>nd</sup> figure indicates to which degree the motor is waterproof.

IP		Definizione / Description	IP		Definizione / Description
0		Non protetto / No protection	0		Non protetto / No protection
1		Protetto da corpi solidi superiori a Ø 50 mm. Protected against solid matter (over Ø 50 mm).	1		Protetto contro la caduta verticale di gocce d'acqua. Protected against drops of water falling vertically.
2		Protetto da corpi solidi superiori a Ø 12 mm. Protected against solid matter (over Ø 12 mm).	2		Protetto contro la caduta verticale di gocce d'acqua con inclinazione max di 15°. Protected against drops of water falling up to 15°.
3		Protetto da corpi solidi superiori a Ø 2.5 mm. Protected against solid matter (over Ø 2.5 mm).	3		Protetto contro la pioggia. Rain proof.
4		Protetto da corpi solidi superiori a Ø 1 mm. Protected against solid matter (over Ø 1 mm).	4		Protetto contro gli spruzzi. Splash proof.
5		Protetto contro la polvere. Dust protected.	5		Protetto contro getti d'acqua. Water jet proof.
6		Totalmente protetto contro la polvere. Fully dust tight.	6		Protetto dalle ondate. Waveproof.
7		N.A.	7		Protetto contro immersione. Immersion up to 1 metre.
8		N.A.	8		Protetto contro immersione/sommersione prolungata. Immersion beyond 1 metre.

**Normative di riferimento**
**Reference Standards**

	Europe EN	World IEC	Italy CEI
<b>Requisiti generali per macchine elettriche</b> <i>General requirements electrical machines</i>	EN 60034-1:2010	IEC 60034-1:2010	CEI EN 60034-1:2010
<b>Classificazione del grado di protezione</b> <i>Classification degree of protection provided by enclosures</i>	EN 60034-5:2001	IEC 60034-5:2001	CEI EN 60034-5:2001
<b>Sistema di raffreddamento</b> <i>Cooling system</i>	EN 60034-6:1993	IEC 60034-6:1993	CEI EN 60034-6:1993
<b>Modalità di montaggio</b> <i>Mounting arrangements</i>	EN 60034-7:1993	IEC 60034-7:1993	CEI EN 60034-7:1993

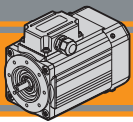

**Tipi di servizi IEC**

**IEC duty cycles**

Il servizio di un motore indica il tipo di utilizzo e la gravosità del ciclo di lavoro.

The duty cycle of a motor indicates its use and running cycle.

Grafico servizi più comuni

Most common duty cycles diagram

N = funzionamento / run  
R = riposo / rest

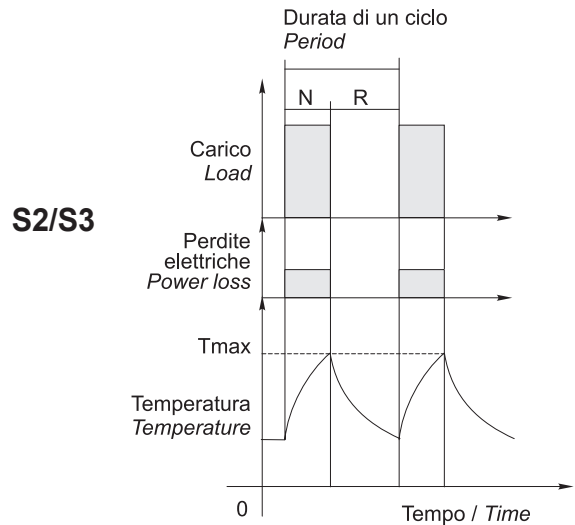
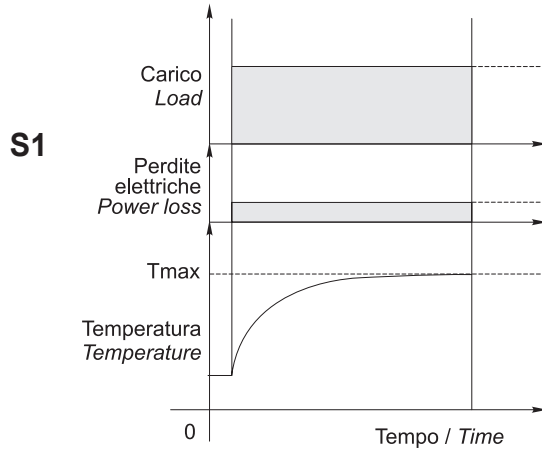

NOTA: Lo stesso motore può essere usato per cicli e servizi diversi, con l'unica limitazione che la temperatura interna non superi mai la Tmax stabilita dalla classe di isolamento termico del motore.

NOTE: The same motor can run under all duty services, limitation is due to internal temperature that must not override Tmax stated by motor thermal class.

**Classe di isolamento termico**

**Insulation class**

La classe termica indica il grado di resistenza alla temperatura interna, nel punto più caldo (avvolgimenti). Isolamento termico classe F.

Thermal insulation class indicates the level of thermal protection measured at the hottest point inside the motor (windings). Thermal insulation class F.

Classe Class	Massima temperatura interna Max. windings temp.
E	120°C
B	130°C
F	155°C
H	180°C

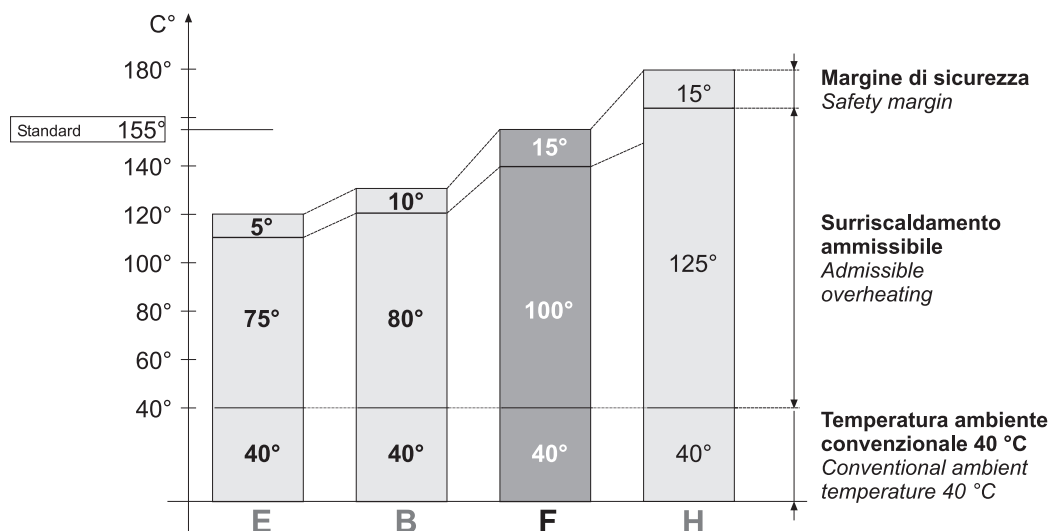

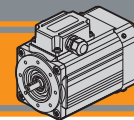

**Serie SM - Funzionamento a 60 Hz**

**Series SM - 60 Hz line power supply**

Velocità, coppia e potenza nominale nel funzionamento a 60 Hz varieranno come da tabella:

Speed, torque and rated power in 60 Hz operation is shown in the following table:

	50 Hz	60 Hz
<b>400 V</b>	Vedi dati tecnici / see technical data 	Velocità / speed ≈ + 20% Coppia / torque ≈ -20% Potenza / power ≈ invariata / the same
<b>480 V</b>	Non permesso / not allowed	Velocità / speed ≈ + 20% Coppia / torque ≈ invariata / the same Potenza / power ≈ + 20%

**Tabella pressacavi**

**Table of cable glands data**

**Serie SMT / SMT Series**

**Serie SMM / SMM Series**

TAGLIA SIZE	Pressacavo Cable gland
50 / 56 / 63	M16x1.5
71	M20x1.5

TAGLIA SIZE	Pressacavo Cable gland
50 / 56 / 63	n°2 - M16x1.5
71	M20x1.5 + M16x1.5

**Connessioni e collegamenti**

**Connection diagram**

**Riferimenti**

**References**

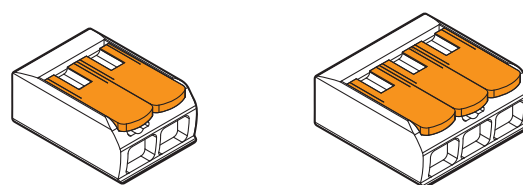
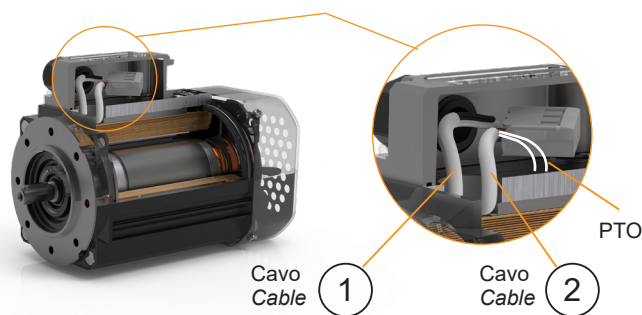

Morsetto di collegamento a leva a 2 e 3 poli  
Splicing connector with lever 2 - and 3 - pin.

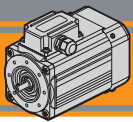

**Connessioni e collegamenti**

**Connection diagram**

**400/460 V - Trifase / Three phase**

**Collegamento a stella / Star connection**

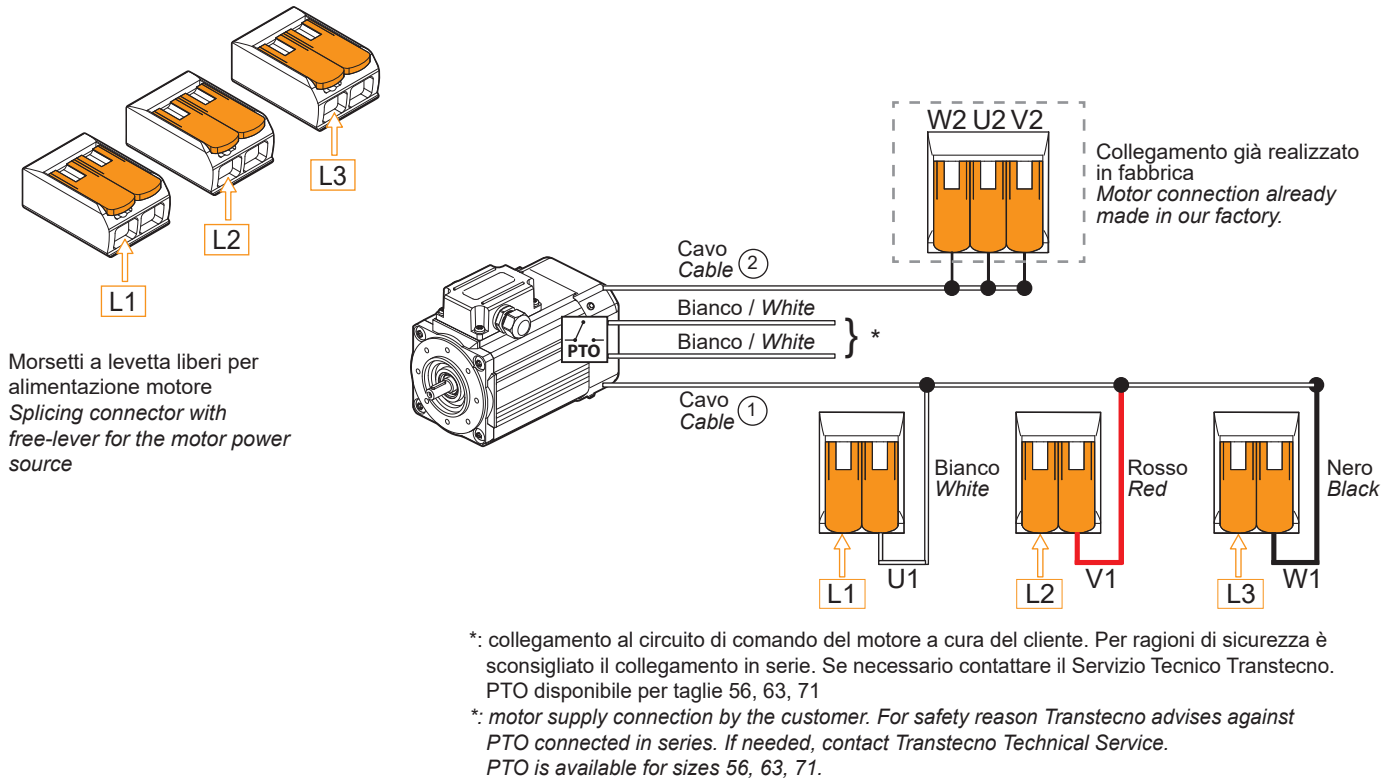

**230 V - Trifase / Three phase**

**Collegamento a triangolo / Delta connection**

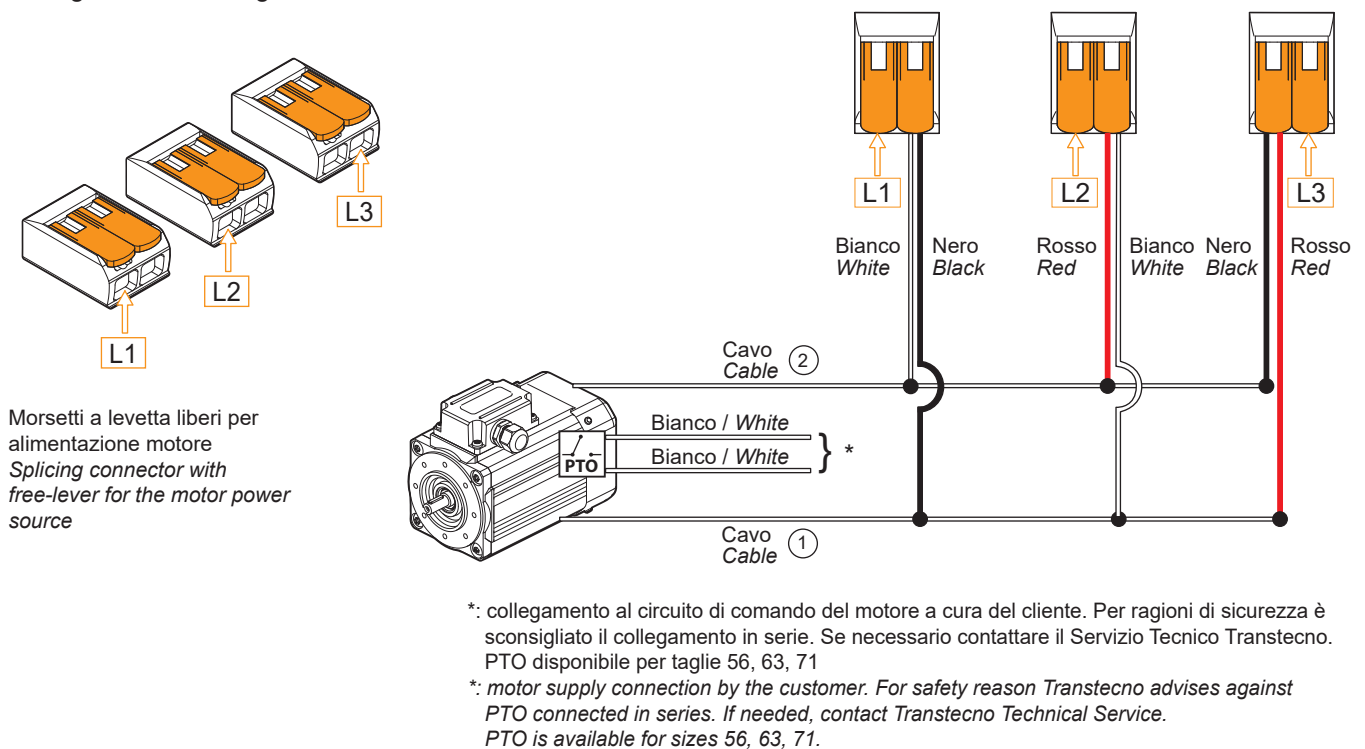

I motori della serie SM sono forniti in collegamento a stella, lo schema di collegamento a triangolo sopra riportato fornisce una chiara indicazione delle modifiche che il cliente può apportare in autonomia. Se necessario contattare il Servizio Tecnico Transtecno.

*The SM series is supplied in star connection, the delta connection diagram shown above provides a clear indication of the modification that the customer can make independently. If needed, contact Transtecno Technical Service.*

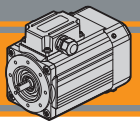

Connessioni e collegamenti

Connection diagram

**230 V - Monofase / Single phase**

Monofase SMM 50... / Single phase SMM 50...

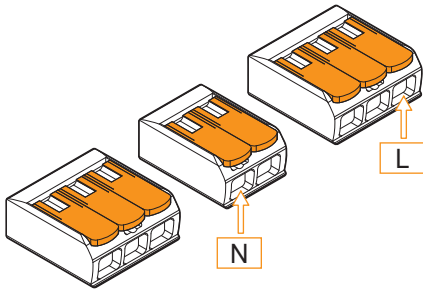

Morsetti a levetta liberi per alimentazione motore  
Splicing connector with free-lever for the motor power source

(1): il condensatore sarà fornito a corredo.  
(1): the capacitor will be supplied separately.

Senso di rotazione antiorario  
Counter-clockwise direction of rotation

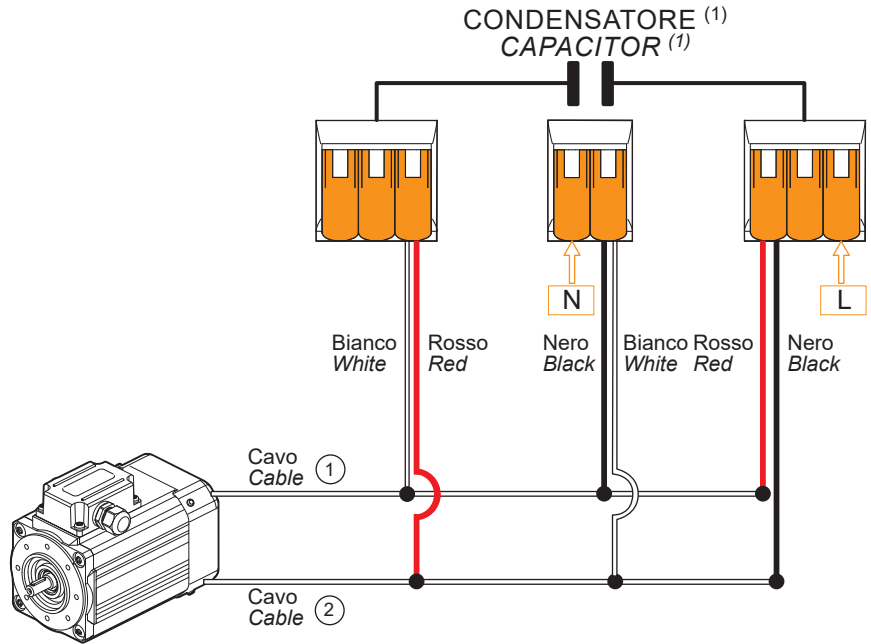
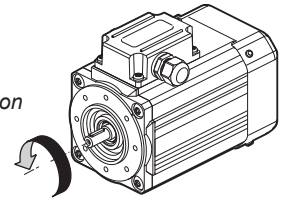

**230 V - Monofase / Single phase**

Monofase SMM 50... / Single phase SMM 50...

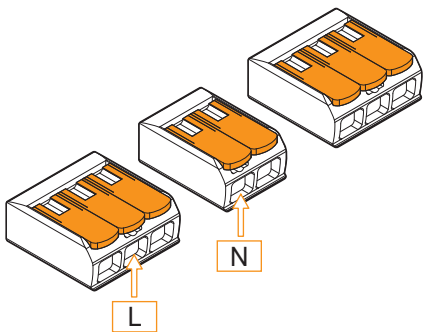

Morsetti a levetta liberi per alimentazione motore  
Splicing connector with free-lever for the motor power source

(1): il condensatore sarà fornito a corredo.  
(1): the capacitor will be supplied separately.

Senso di rotazione orario  
Clockwise direction of rotation

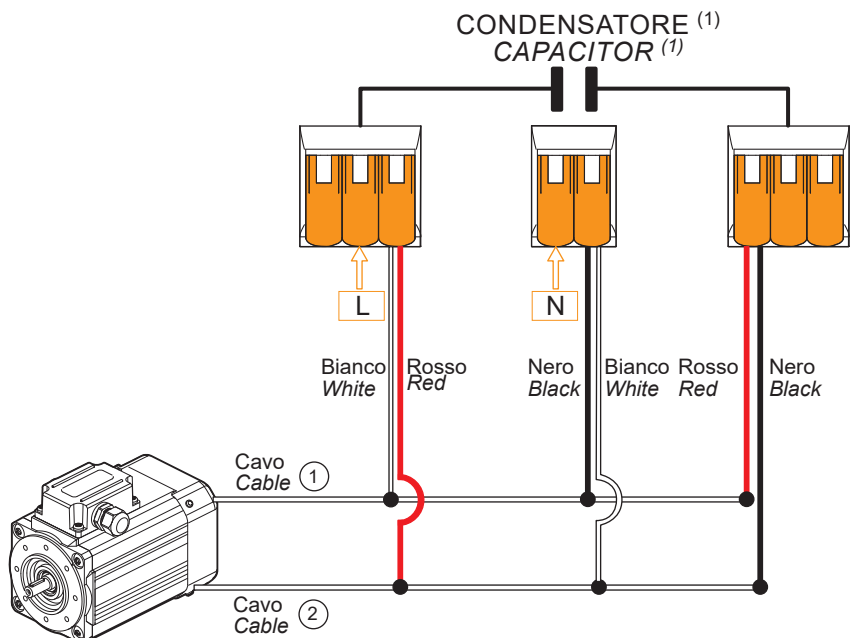
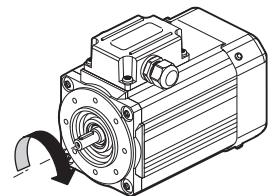

AC

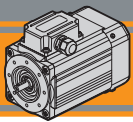

Connessioni e collegamenti

Connection diagram

230 V - Monofase / Single phase

Monofase da SMM 56... a SMM 71... / Single phase from SMM 56... to SMM 71...

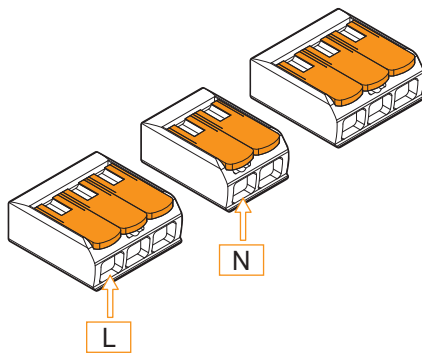

Morsetti a levetta liberi per alimentazione motore  
Splicing connector with free-lever for the motor power source

Senso di rotazione orario  
Clockwise direction of rotation

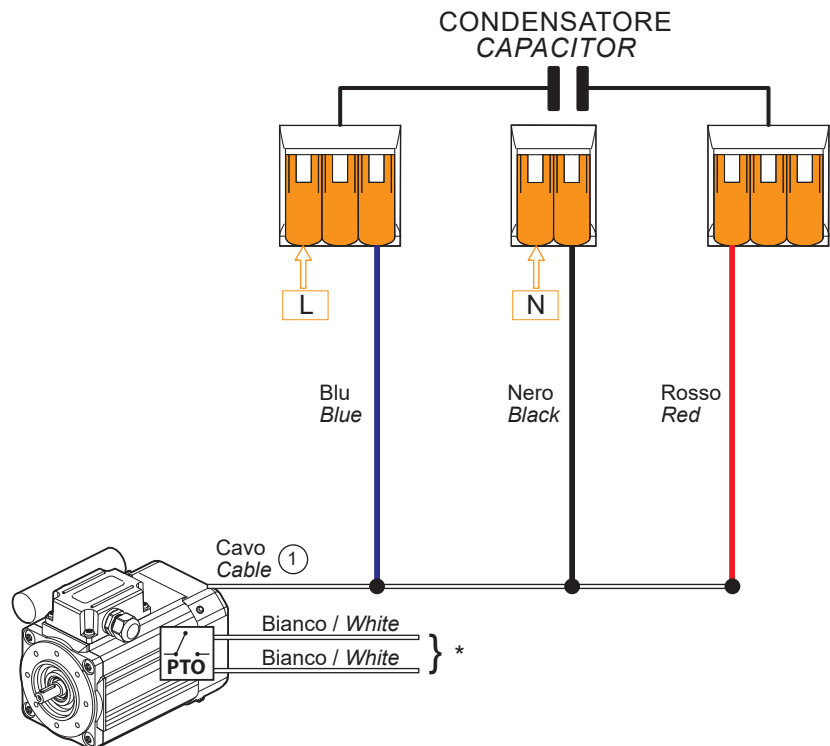
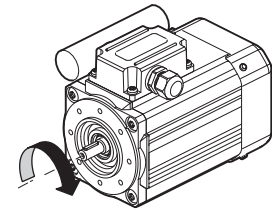

\*: collegamento al circuito di comando del motore a cura del cliente. Per ragioni di sicurezza è sconsigliato il collegamento in serie. Se necessario contattare il Servizio Tecnico Transtecno. PTO disponibile per taglie 56, 63, 71

\*: motor supply connection by the customer. For safety reason Transtecno advises against PTO connected in series. If needed, contact Transtecno Technical Service. PTO is available for sizes 56, 63, 71.

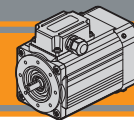

Connessioni e collegamenti

Connection diagram

**230 V - Monofase / Single phase**

Monofase da SMM 56... a SMM 71... / Single phase from SMM 56... to SMM 71...

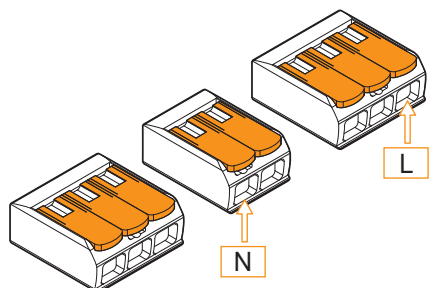

Morsetti a levetta liberi per alimentazione motore  
Splicing connector with free-lever for the motor power source

Senso di rotazione antiorario  
Counter-clockwise direction of rotation

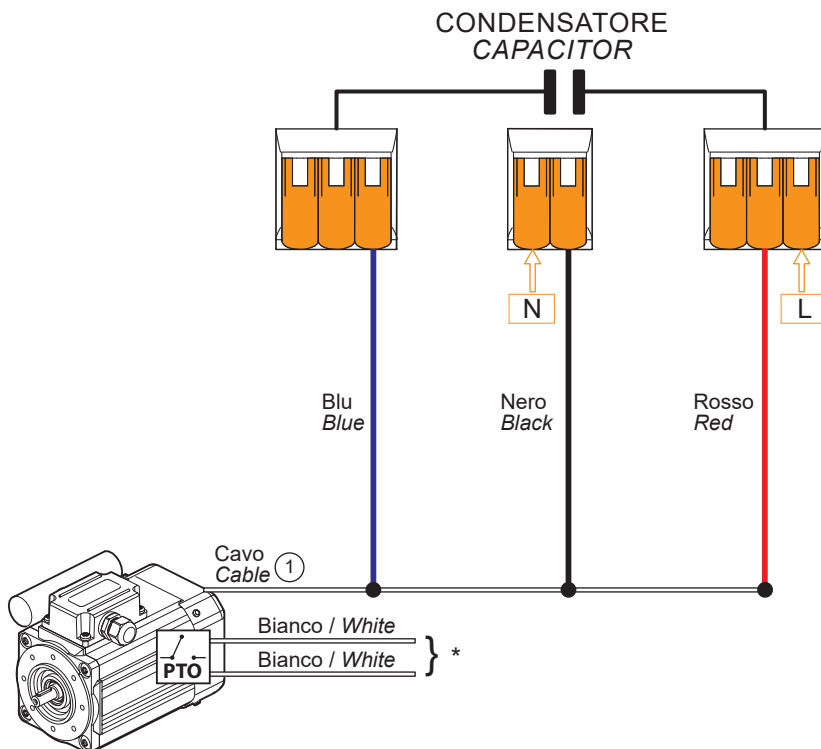
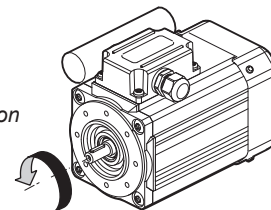

\*: collegamento al circuito di comando del motore a cura del cliente. Per ragioni di sicurezza è sconsigliato il collegamento in serie. Se necessario contattare il Servizio Tecnico Transtecno. PTO disponibile per taglie 56, 63, 71

\*: motor supply connection by the customer. For safety reason Transtecno advises against PTO connected in series. If needed, contact Transtecno Technical Service. PTO is available for sizes 56, 63, 71.

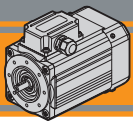

**Targhetta**

**Nameplate**

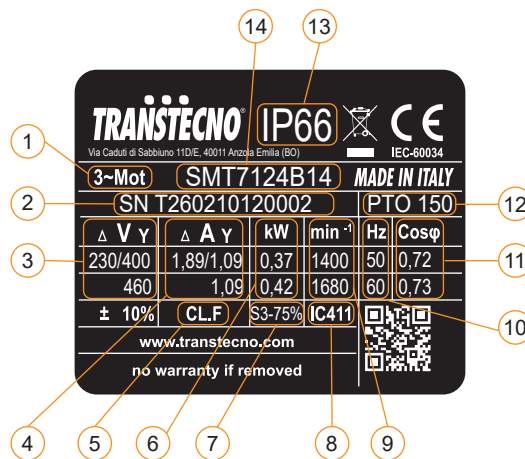

Pos.	Descrizione	Description
1	Tipo di alimentazione	Power supply
2	Numero di serie	Serial number
3	Tensione di alimentazione	Supply voltage
4	Corrente nominale	Rated current
5	Classe di isolamento	Insulation class
6	Potenza nominale	Rated power
7	Servizio	Duty
8	Ventilazione	Fan cooling
9	Velocità nominale	Rated speed
10	Frequenza nominale	Rated frequency
11	Fattore di potenza	Power factor
12	Protezione termica PTO 150°C	PTO 150°C Thermal protection
13	Grado di protezione IP	IP protection rating
14	Tipo motore	Motor type

**MINI**  **TECNO**™  
**small** but strong

**SM..BR**



**Motori elettrici CA autofrenanti**  
**AC electric motors with brake**



**MINI**  **TECNO**™ brand of  
**TRANSTECNO**®



AC



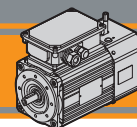

BRAKE

<b>Indice</b>	<b>Index</b>	Pag. Page
Caratteristiche tecniche	<i>Technical features</i>	<b>AB2</b>
Designazione	<i>Classification</i>	<b>AB2</b>
Simbologia e formule	<i>Symbols and formulas</i>	<b>AB3</b>
Dati tecnici	<i>Technical data</i>	<b>AB3</b>
Dimensioni motori trifase	<i>Three phase motors dimensions</i>	<b>AB4</b>
Cava esagonale	<i>Hexagonal socket</i>	<b>AB5</b>
Opzione guarnizione CA	<i>Rubber gasket option</i>	<b>AB5</b>
Gradi di protezione IP	<i>IP protection rating</i>	<b>AB6</b>
Tipo di servizio IEC	<i>IEC duty cycles</i>	<b>AB7</b>
Classe di isolamento termico	<i>Insulation class</i>	<b>AB7</b>
Tabella pressacavi	<i>Table of cable glands data</i>	<b>AB7</b>
Connessioni e collegamenti	<i>Connection diagram</i>	<b>AB8</b>
Targhetta	<i>Nameplate</i>	<b>AB9</b>

Questa sezione annulla e sostituisce ogni precedente edizione o revisione. Qualora questa sezione non Vi sia giunta in distribuzione controllata, l'aggiornamento dei dati ivi contenuto non è assicurato. **In tal caso la versione più aggiornata è disponibile sul nostro sito internet [www.transtecno.com](http://www.transtecno.com)**

*This section replaces any previous edition and revision. If you obtained this catalogue other than through controlled distribution channels, the most up to date content is not guaranteed. In this case the latest version is available on our web site [www.transtecno.com](http://www.transtecno.com)*

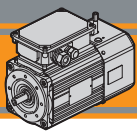

**Caratteristiche tecniche**

**Technical characteristics**

I motori autofrenanti delle serie SMT..BR hanno le seguenti caratteristiche principali:

*SMT..BR braked motor range has the following main features:*

- Costruzione compatta
- Motorizzazioni in corrente alternata trifase
- Carcasa estrusa in alluminio anodizzato nero
- Motore elettrico AC con grado di protezione IP66 (freno IP66 e IP65)
- Rumorosità e vibrazioni contenute
- Isolamento termico di classe F
- Flangia motore IEC B14
- Temperatura ambiente: 0°C / + 40°C (Per utilizzo a temperature diverse contattare il ns. servizio tecnico)
- Disponibili nella versione ventilata TEFC (servizio S1)
- Protezioni termiche PTO 150°C
- Adatti al funzionamento con alimentazione da inverter (Richiedere opzione freno con alimentazione separata)
- Cava esagonale su albero motore lato NDE.
- La tolleranza di tensione è ±10% per tutti i motori
- Il freno è a corrente continua

- *Compact design*
- *AC three phase motors available*
- *Black anodized extruded aluminium housing*
- *AC electric motor in IP66 protection Standard (IP66 and IP65 brake)*
- *Low noise and vibrations*
- *Class F insulation Standard*
- *Motor flange IEC B14*
- *Ambient temperature: 0°C / +40°C (For different temperatures contact Transtecno Technical Dept)*
- *Fan cooled TEFC (duty S1) available*
- *PTO 150°C thermal protection*
- *Suitable for running with frequency converter (Request brake option with separate power supply)*
- *Motor shaft hexagon socket on the NDE side*
- *The voltage tolerance is ±10% for all motors*
- *The brake is DC*

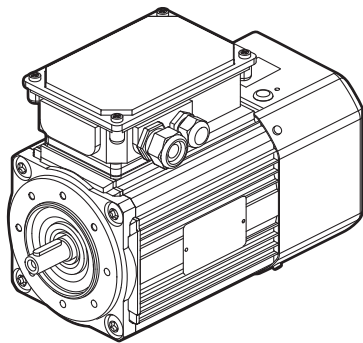

**SMT..TEFC BR**

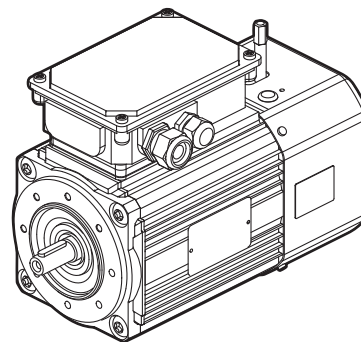

**SMT..TEFC BRL**



**Designazione**

**Classification**

MOTORE TRIFASE AUTOFRENANTE / THREE PHASE BRAKED MOTOR									
SMT	63	2	4	0.18 kW	B14	230-400 V	50 Hz	TEFC	BR
Tipo Type	Grandezza Size	Indicativo potenza Power coefficient	Poli Poles	Potenza Power	Forma costruttiva Version	Tensione Voltage	Frequenza Frequency	Ventilazione Fan cooling	Freno - Leva di sblocco Brake - Hand-release lever
SMT	Vedi tabelle See tables	<b>1-2-3-4-5</b>	<b>4</b>	<b>0.18 kW</b> ... <b>0.55 kW</b>	<b>B14</b>	<b>230-400 V</b>  <b>460V</b> a richiesta on request	<b>50Hz</b>  <b>60Hz</b>	<b>TEFC</b>	<b>BR</b>  <b>BRL</b>

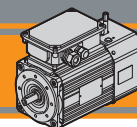

Simbologia e formule

Symbols and formulas

$P_n$	[kW]	Potenza nominale	Rated power
$I_n$	[A]	Corrente nominale (a 400V)	Rated current (at 400V)
$M_n$	[Nm]	Coppia nominale	Rated torque
$n_n$	[rpm]	Velocità nominale	Rated speed
$M_s / M_n$		Rapporto coppia spunto / coppia nominale	Ratio start torque / rated torque
$M_k / M_n$		Rapporto coppia massima / coppia nominale	Ratio max torque / rated torque
$M_b$	[Nm]	Coppia frenante	Braking torque
$I_s / I_n$		Rapporto corrente di spunto / corrente nominale	Ratio start current / rated current
$\cos\phi$		Fattore di potenza al carico nominale	Power factor at rated torque load
$\eta$		Rendimento al carico nominale	Efficiency at rated torque load
Potenza Power	[HP]	Potenza [kW] x 1.341	Power [kW] x 1.341
Potenza resa $P_n$ $P_n$ output power	[kW]	Potenza assorbita x $\eta$	Absorbed power x $\eta$
Pot. assorbita Absorbed power	[kW]	$\frac{\sqrt{x} \cdot I \cdot x \cdot \cos\phi}{1000}$ (monofase)	$\frac{\sqrt{x} \cdot I \cdot x \cdot \cos\phi}{1000}$ (singlephase)
		$\frac{\sqrt{x} \cdot I \cdot x \cdot \sqrt{3} \cdot x \cdot \cos\phi}{1000}$ (trifase)	$\frac{\sqrt{x} \cdot I \cdot x \cdot \sqrt{3} \cdot x \cdot \cos\phi}{1000}$ (threephase)
$I_n$ (230 V)		$I_n$ (400 V) x $\sqrt{3}$	$I_n$ (400 V) x $\sqrt{3}$

Dati tecnici

Technical data

SMT..BR Motori trifase autofrenanti / SMT..BR Three phase motors with brake (230-400 V / 50 Hz) poli / poles 4

TAGLIA SIZE	$P_n$ [kW]	$M_n$ [Nm]	$n_n$ [min <sup>-1</sup> ]	$I_n$ (400V) [A]	$\eta$ %	$\cos\phi$	$M_s/M_n$	$I_s/I_n$	$M_k/M_n$	PTO [°C]	Servizio Duty TEFC	IP Motore Motor	$M_b$ [Nm]	IP Freno Brake
SMT6324B14BR(L)	0.18	1.26	1360	0.69	57.0	0.66	2.50	2.90	2.50	PTO 150°	S3 75%	66	4	66
SMT6334B14BR(L)	0.25	1.74	1375	0.94	62.0	0.64	2.80	3.00	2.80				4	66
SMT7124B14BR(L)	0.37	2.52	1400	1.10	67.9	0.72	2.75	4.20	2.75				7,5	65
SMT7134B14BR(L)	0.55	3.76	1395	1.55	70.2	0.73	2.90	4.40	2.90				7,5	65

I freni adottati sono freni elettromagnetici ad azione negativa: l'azione frenante viene quindi esercitata in assenza di alimentazione.

Il freno è a corrente continua e, in configurazione standard, viene alimentato direttamente da una fase del motore, passando attraverso un raddrizzatore alloggiato all'interno della morsetteria. Per le applicazioni in cui si rende necessario, come ad esempio l'azionamento tramite inverter, è possibile richiedere l'alimentazione del freno separata 230Vac ±10% 50Hz. Sono disponibili anche le versioni 400Vac ±10% 50Hz o 24Vdc.

La leva di sblocco è una opzione che va specificata in fase di ordine.

The brakes adopted are negative action electromagnetic brakes: the braking action is performed in the absence of power.

The brake is DC and, in standard configuration, is powered directly by a phase of the motor, passing through a rectifier housed inside the terminal block. For the applications in which it is required, like the ones with motor driven by inverter, it is possible to request 230Vac ± 10% 50Hz separate brake power supply. 400Vac ± 10% 50Hz or 24Vdc power supply are available on request.

The release lever is an option that must be requested when ordering.

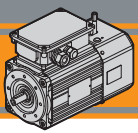

Dimensioni motori trifase

Three phase motors dimensions

3~

**SMT63.. - B14 - TEFC - BR (L)**

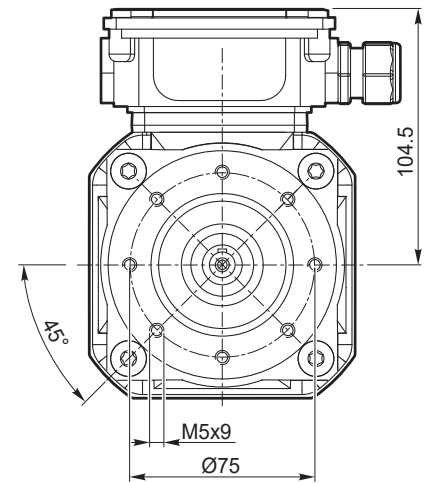
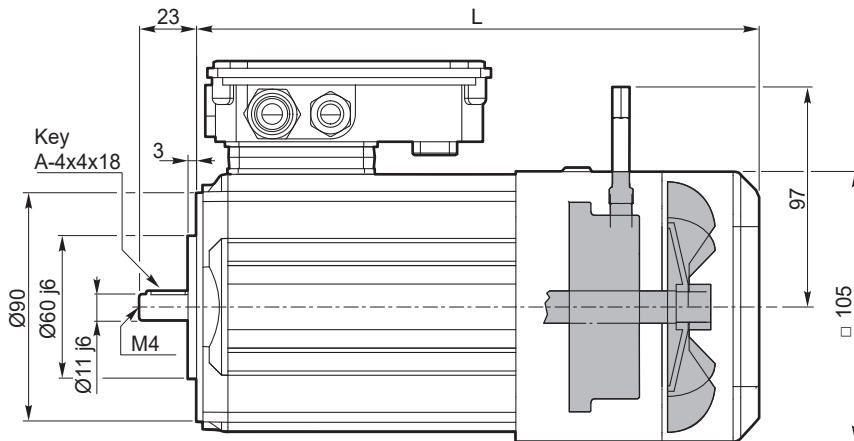

**Nota:**

La leva di sblocco è una opzione che va specificata in fase di ordine.

**Note:**

The release lever is an option that must be requested when ordering.

SMT..BR	... TEFC	
	L	Kg
6324	211	5.8
6334	226	6.5

3~

**SMT71.. - B14 - TEFC - BR (L)**

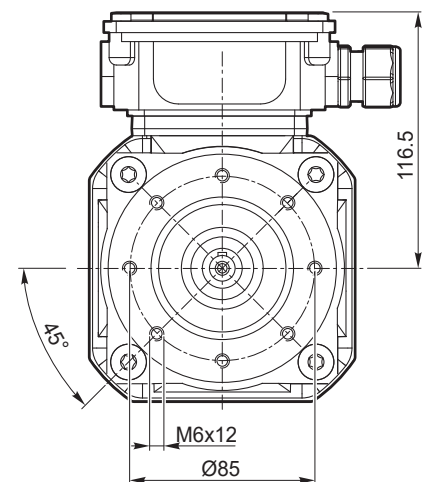
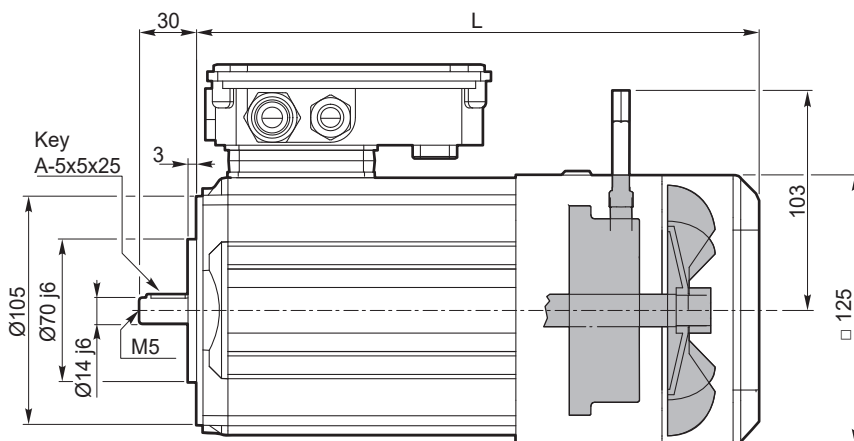

**Nota:**

La leva di sblocco è una opzione che va specificata in fase di ordine.

**Note:**

The release lever is an option that must be requested when ordering.

SMT..BR	... TEFC	
	L	Kg
7124	221	7.8
7134	236	8.9

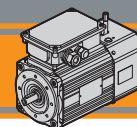

**Cava esagonale**

**Hexagonal socket**

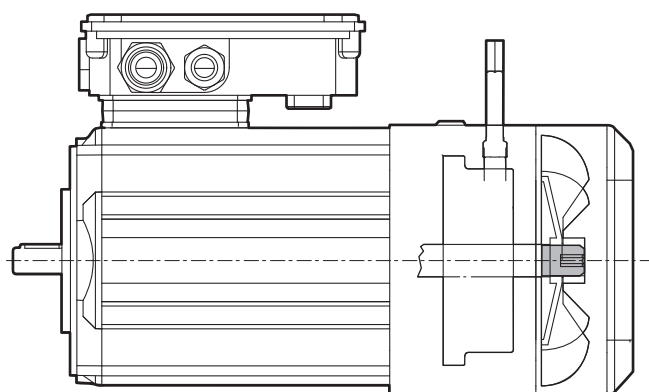

Esagono / Hexagon

SM..	E
63	4
71	6

**Nota:**

Installare a monte dell'alimentazione un dispositivo che assicuri la disconnessione della rete omnipolare, durante le operazioni di rotazione manuale è obbligatorio l'utilizzo di tale sezionatore.

Il quadro elettrico del motore deve essere lucchettabile al fine di evitare il riarmo non previsto alla rete elettrica.

E' severamente vietata la messa in servizio del motore elettrico senza copriventola opportunamente montata.

**Note:**

An omnipolar cut-off device must be fitted upstream of the power supply; the use of this device is mandatory during manual rotation operations.

The switchgear for the motor must be padlockable in order to prevent the power supply from being accidentally reset. It is strictly prohibited to put the electric motor into service if the fan cover is not fitted.

**Opzione guarnizione CA**

**Rubber gasket option**

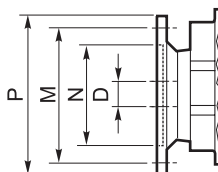
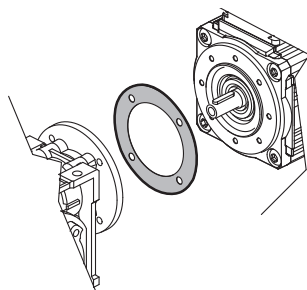

Dimensioni IEC / IEC Dimensions		
	63 B14	71 B14
N	60	70
M	75	85
P	90	105
D	11	14

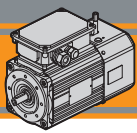

**Grado di protezione IP**

**IP protection rating**

Indica il grado di isolamento meccanico del corpo motore.









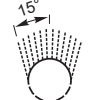

1<sup>a</sup> cifra protezione alla penetrazione di corpi solidi.

2<sup>a</sup> cifra protezione contro la penetrazione d'acqua.

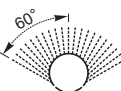
IP protection rating indicates the degree of mechanical insulation of the motor casing.

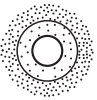
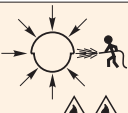
The 1<sup>st</sup> figure indicates the level of protection against the intrusion of solid matter.

The 2<sup>nd</sup> figure indicates to which degree the motor is waterproof.

IP		Definizione / Description	IP		Definizione / Description
0		Non protetto / No protection	0		Non protetto / No protection
1		Protetto da corpi solidi superiori a Ø 50 mm. Protected against solid matter (over Ø 50 mm).	1		Protetto contro la caduta verticale di gocce d'acqua. Protected against drops of water falling vertically.
2		Protetto da corpi solidi superiori a Ø 12 mm. Protected against solid matter (over Ø 12 mm).	2		Protetto contro la caduta verticale di gocce d'acqua con inclinazione max di 15°. Protected against drops of water falling up to 15°.
3		Protetto da corpi solidi superiori a Ø 2.5 mm. Protected against solid matter (over Ø 2.5 mm).	3		Protetto contro la pioggia. Rain proof.
4		Protetto da corpi solidi superiori a Ø1 mm. Protected against solid matter (over Ø1 mm).	4		Protetto contro gli spruzzi. Splash proof.
5		Protetto contro la polvere. Dust protected.	5		Protetto contro getti d'acqua. Water jet proof.
6		Totalmente protetto contro la polvere. Fully dust tight.	6		Protetto dalle ondate. Waveproof.
7	N.A.	N.A.	7		Protetto contro immersione. Immersion up to 1 metre.
8	N.A.	N.A.	8		Protetto contro immersione/sommersione prolungata. Immersion beyond 1 metre.

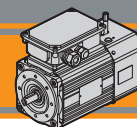

**Tipi di servizi IEC**

**IEC duty cycles**

Il servizio di un motore indica il tipo di utilizzo e la gravosità del ciclo di lavoro.

The duty cycle of a motor indicates its use and running cycle.

Grafico servizi più comuni

Most common duty cycles diagram

N = funzionamento / run  
R = riposo / rest

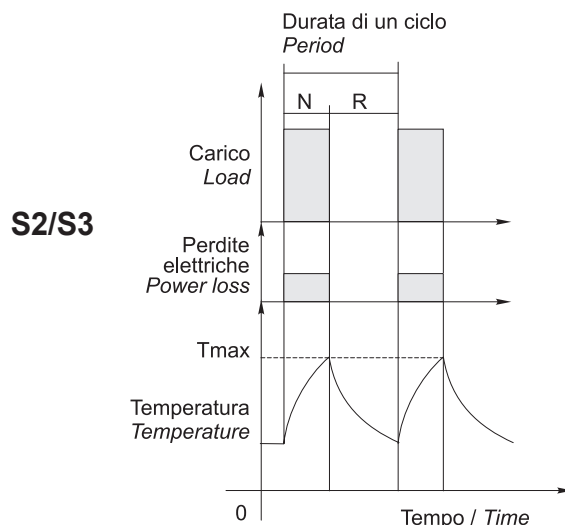
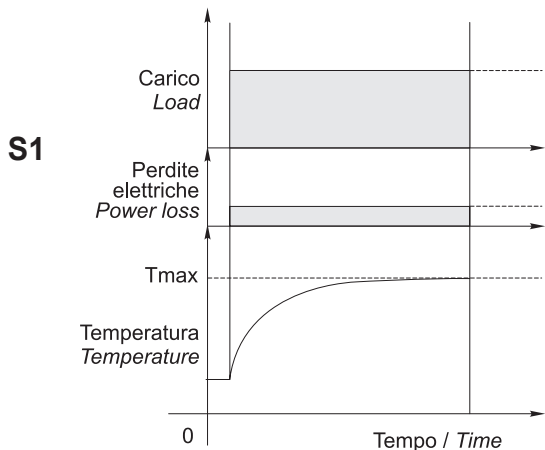

NOTA: Lo stesso motore può essere usato per cicli e servizi diversi, con l'unica limitazione che la temperatura interna non superi mai la Tmax stabilita dalla classe di isolamento termico del motore.

NOTE: The same motor can run under all duty services, limitation is due to internal temperature that must not override Tmax stated by motor thermal class.

**Classe di isolamento termico**

**Insulation class**

La classe termica indica il grado di resistenza alla temperatura interna, nel punto più caldo (avvolgimenti). Isolamento termico classe F.

Thermal insulation class indicates the level of thermal protection measured at the hottest point inside the motor (windings). Thermal insulation class F.

Classe Class	Massima temperatura interna Max. windings temp.
E	120°C
B	130°C
F	155°C
H	180°C

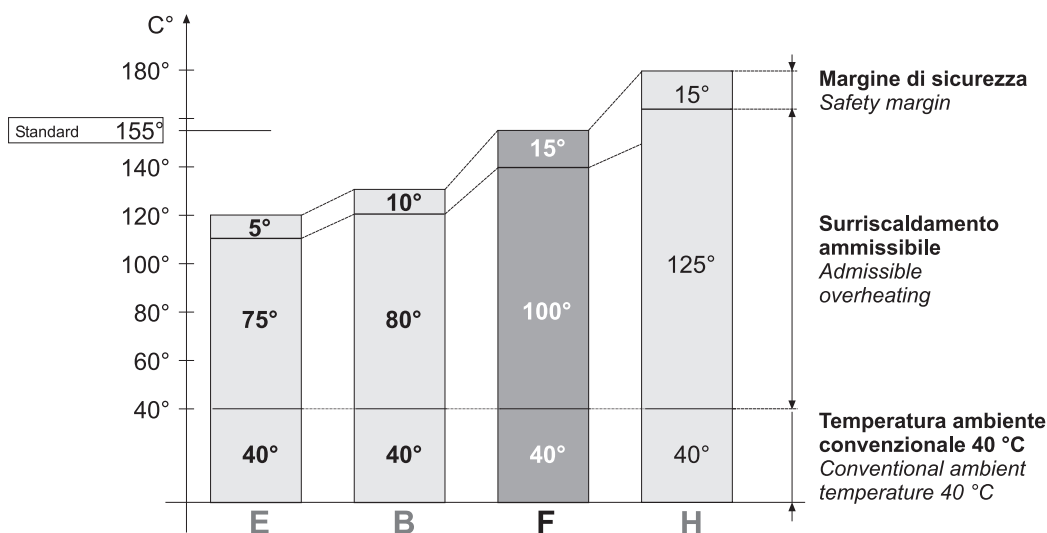

**Tabella pressacavi**

**Table of cable glands data**

Serie **SM..BR** / **SM..BR** Series

TAGLIA SIZE	Pressacavo Cable gland
63 / 71	1x M20x1.5

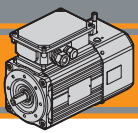

**Connessioni e collegamenti**

**Connection diagram**

**Riferimenti**

**References**

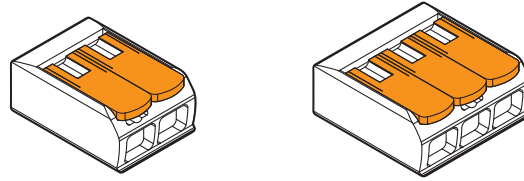

Morsetto di collegamento a leva a 2 e 3 poli  
Splicing connector with lever 2 - and 3 - pin.

**400/460 V - Trifase / three phase**

**Collegamento a stella / Star connection**

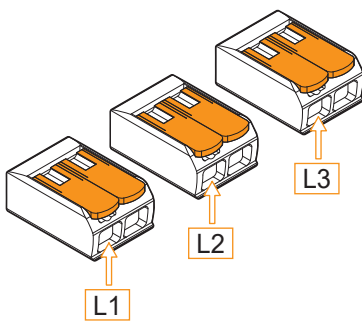

Morsetti a levetta liberi per alimentazione motore  
Splicing connector with free-lever for the motor power source

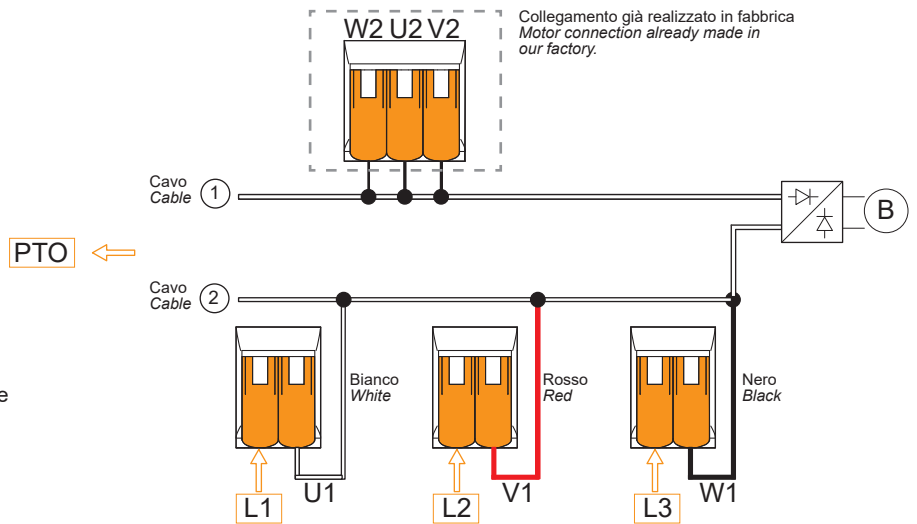

**230 V - Trifase / three phase**

**Collegamento a triangolo / Delta connection**

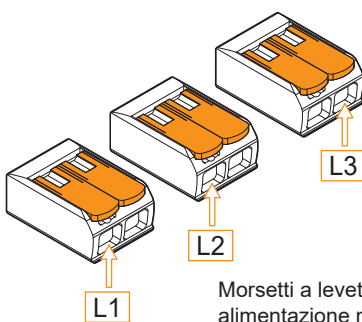

Morsetti a levetta liberi per alimentazione motore  
Splicing connector with free-lever for the motor power source

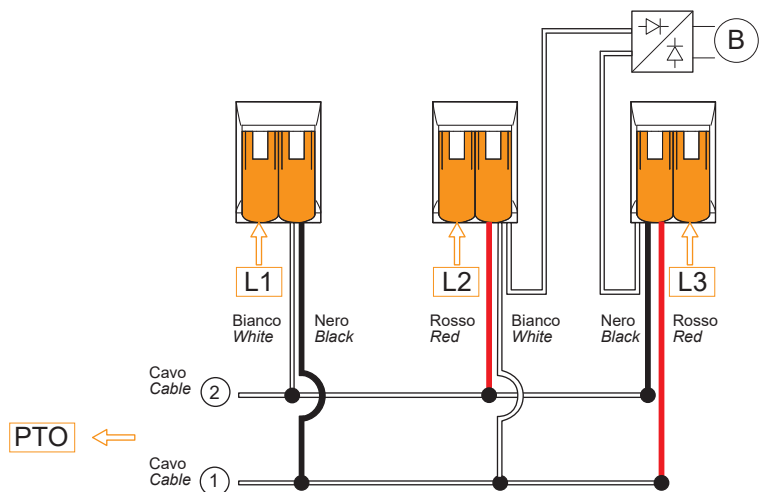

I motori della serie SM sono forniti in collegamento a stella, lo schema di collegamento a triangolo sopra riportato fornisce una chiara indicazione delle modifiche che il cliente può apportare in autonomia. Se necessario contattare il Servizio Tecnico Transtecno.

The SM series is supplied in star connection, the delta connection diagram shown above provides a clear indication of the modification that the customer can make independently. If needed, contact Transtecno Technical Service.

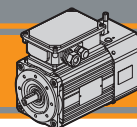

Targhetta

Nameplate

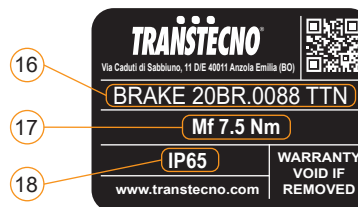
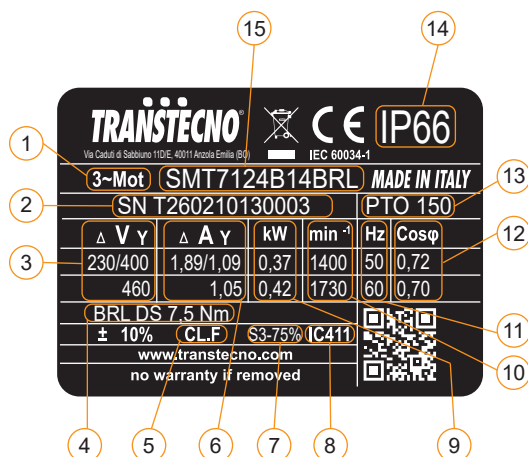

Pos.	Descrizione	Description
1	Tipo di alimentazione	Power supply
2	Numero di serie	Serial number
3	Tensione di alimentazione	Supply voltage
4	Tipo freno	Brake type
5	Classe di isolamento	Insulation class
6	Corrente nominale	Rated current
7	Servizio	Duty
8	Ventilazione	Fan cooling
9	Potenza nominale	Rated power
10	Velocità nominale	Rated speed
11	Frequenza nominale	Rated frequency
12	Fattore di potenza	Power factor
13	Protezione termica PTO 150°C	PTO 150°C Thermal protection
14	Grado di protezione IP motore	Motor IP protection rating
15	Tipo motore	Motor type
16	Codice freno	Brake code
17	Coppia frenante	Braking torque
18	Grado di protezione IP freno	Brake IP protection rating



**MINI**  **TECNO**™  
**small** but strong

**SM..SV**



Motori elettrici CA servoventilati  
AC electric motors with forced-ventilation



**MINI**  **TECNO**™ brand of  
**TRANSTECNO**®



AC



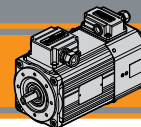

<b>Indice</b>	<b>Index</b>	Pag. Page
Caratteristiche tecniche	<i>Technical features</i>	<b>AC2</b>
Designazione	<i>Classification</i>	<b>AC2</b>
Simbologia e formule	<i>Symbols and formulas</i>	<b>AC3</b>
Dati tecnici	<i>Technical data</i>	<b>AC3</b>
Dimensioni motori trifase	<i>Three phase motors dimensions</i>	<b>AC4</b>
Opzione guarnizione CA	<i>Rubber gasket option</i>	<b>AC5</b>
Gradi di protezione IP	<i>IP protection rating</i>	<b>AC5</b>
Tipo di servizio IEC	<i>IEC duty cycles</i>	<b>AC6</b>
Classe di isolamento termico	<i>Insulation class</i>	<b>AC6</b>
Serie SM - Funzionamento a 60 Hz	<i>Series SM - 60 Hz line power supply</i>	<b>AC7</b>
Tabella pressacavi	<i>Table of cable glands data</i>	<b>AC7</b>
Connessioni e collegamenti - Motore	<i>Connection diagram - Motor</i>	<b>AC7</b>
Connessioni e collegamenti - Servoventola	<i>Connection diagram - Servo fan</i>	<b>AC9</b>
Targhetta	<i>Nameplate</i>	<b>AC10</b>

Questa sezione annulla e sostituisce ogni precedente edizione o revisione. Qualora questa sezione non Vi sia giunta in distribuzione controllata, l'aggiornamento dei dati ivi contenuto non è assicurato. **In tal caso la versione più aggiornata è disponibile sul nostro sito internet [www.transtecno.com](http://www.transtecno.com)**

*This section replaces any previous edition and revision. If you obtained this catalogue other than through controlled distribution channels, the most up to date content is not guaranteed. In this case the latest version is available on our web site [www.transtecno.com](http://www.transtecno.com)*

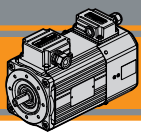

**Caratteristiche tecniche**

**Technical characteristics**

I motori della serie SMT..SV hanno le seguenti caratteristiche principali:

SMT..SV motor range has the following main features:

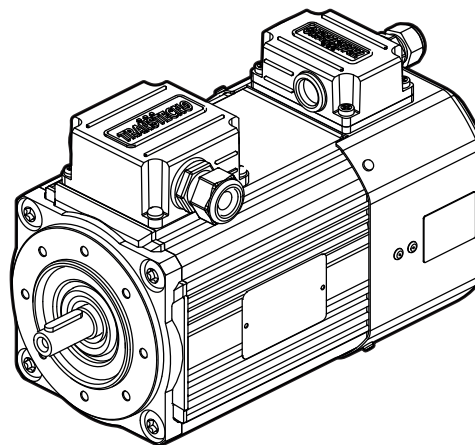

- Costruzione compatta
  - Motorizzazioni in corrente alternata trifase
  - Carcasa estrusa in alluminio anodizzato nero
  - Motore elettrico AC con grado di protezione IP 66 (solo motore - servoventola con grado di protezione IP44)
  - Rumorosità e vibrazioni contenute
  - Isolamento termico di classe F
  - Flangia motore IEC B14
  - Temperatura ambiente: 0°C / + 40°C (Per utilizzo a temperature diverse contattare il ns. servizio tecnico)
  - Protezioni termiche PTO 150°C
  - Adatti al funzionamento con alimentazione da inverter
  - La tolleranza di tensione è ±10% per tutti i motori
- Compact design
  - AC three phase motors available
  - Black anodized extruded aluminium housing
  - AC Electric motors with IP66 Protection standard (only motor - Servo fan with IP44 protection Standard)
  - Low noise and vibrations
  - Class F insulation Standard
  - Motor flange IEC B14
  - Ambient temperature: 0°C / +40°C (For different temperatures contact Transtecno Technical Dept)
  - PTO 150°C thermal protection
  - Suitable for running with frequency converter
  - The voltage tolerance is ±10% for all motors



**SMT..SV**

**Designazione**

**Classification**

MOTORE TRIFASE SERVOVENTILATO / THREE PHASE MOTOR WITH FORCED-VENTIATION								
SMT	63	2	4	0.18 kW	B14	230-400 V	50 Hz	SV
Tipo Type	Grandezza Size	Indicativo potenza Power coefficient	Poli Poles	Potenza Power	Forma costruttiva Version	Tensione Voltage	Frequenza Frequency	Ventilazione Fan cooling
<b>SMT</b>	Vedi tabelle See tables	<b>1-2-3-4-5</b>	<b>4</b>	<b>0.18 kW</b> ... <b>0.75 kW</b>	<b>B14</b>	<b>230-400 V</b>  <b>460V</b> a richiesta on request	<b>50Hz</b>  <b>60Hz</b>	<b>SV</b>
								
								

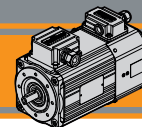

**Simbologia e formule**

**Symbols and formulas**

$P_n$	[kW]	Potenza nominale	Rated power
$I_n$	[A]	Corrente nominale (a 400V)	Rated current (at 400V)
$M_n$	[Nm]	Coppia nominale	Rated torque
$n_n$	[rpm]	Velocità nominale	Rated speed
$M_s / M_n$		Rapporto coppia spunto / coppia nominale	Ratio start torque / rated torque
$M_k / M_n$		Rapporto coppia massima / coppia nominale	Ratio max torque / rated torque
$I_s / I_n$		Rapporto corrente di spunto / corrente nominale	Ratio start current / rated current
$\cos\phi$		Fattore di potenza al carico nominale	Power factor at rated torque load
$\eta$		Rendimento al carico nominale	Efficiency at rated torque load
$P_{sf}$	[W]	Potenza assorbita servoventola	Electric fan power
Potenza Power	[HP]	Potenza [kW] x 1.341	Power [kW] x 1.341
Potenza resa $P_n$ $P_n$ output power	[kW]	Potenza assorbita x $\eta$	Absorbed power x $\eta$
Pot. assorbita Absorbed power	[kW]	$\frac{\sqrt{x} \cdot I \cdot \cos\phi}{1000}$ (monofase)	$\frac{\sqrt{x} \cdot I \cdot \cos\phi}{1000}$ (singlephase)
		$\frac{\sqrt{x} \cdot I \cdot \sqrt{3} \cdot \cos\phi}{1000}$ (trifase)	$\frac{\sqrt{x} \cdot I \cdot \sqrt{3} \cdot \cos\phi}{1000}$ (threephase)
$I_n$ (230 V)		$I_n$ (400 V) x $\sqrt{3}$	$I_n$ (400 V) x $\sqrt{3}$

**Dati tecnici**

**Technical data**

**SMT..SV Motori trifase servoventilati / SMT..SV Three phase motors with forced-ventilation** (230-400 V / 50 Hz) poli / poles **4**

TAGLIA SIZE	$P_n$ [kW]	$M_n$ [Nm]	$n_n$ [min <sup>-1</sup> ]	$I_n$ (400V) [A]	$\eta$ %	$\cos\phi$	$M_s/M_n$	$I_s/I_n$	$M_k/M_n$	PTO [°C]	Servizio Duty SV	IP Motore Motor	IP Servoventola Foced vent.	$P_{sf}$ [W]
SMT6324B14.SV	0.18	1.26	1360	0.69	57.0	0.66	2.50	2.90	2.50	PTO 150°	S3 75%	66	44	11-9
SMT6334B14.SV	0.25	1.74	1375	0.94	62.0	0.64	2.80	3.00	2.80				44	11-9
SMT6344B14.SV	0.37	2.60	1360	1.24	65.3	0.66	2.70	3.00	2.70				44	11-9
SMT7124B14.SV	0.37	2.52	1400	1.10	67.9	0.72	2.75	4.20	2.75				44	14-16
SMT7134B14.SV	0.55	3.76	1395	1.55	70.2	0.73	2.90	4.40	2.90				44	14-16
SMT7144B14.SV	0.75	5.09	1405	2.00	74.0	0.73	2.90	5.00	2.90				44	14-16

Alimentazione della servoventola: 200-240 Vac / 50-60 Hz

Forced ventilation supply voltage: 200-240 Vac / 50-60 Hz

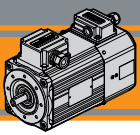

Dimensioni motori trifase

Three phase motors dimensions

3 ~

**SMT63.. - B14 - SV**

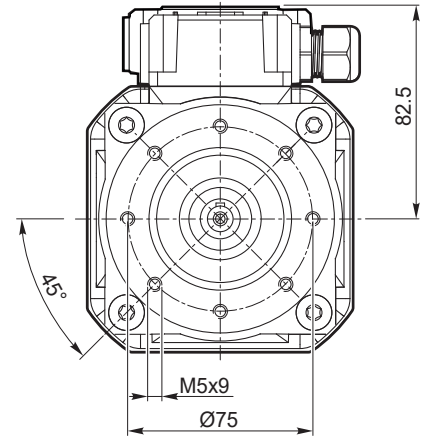
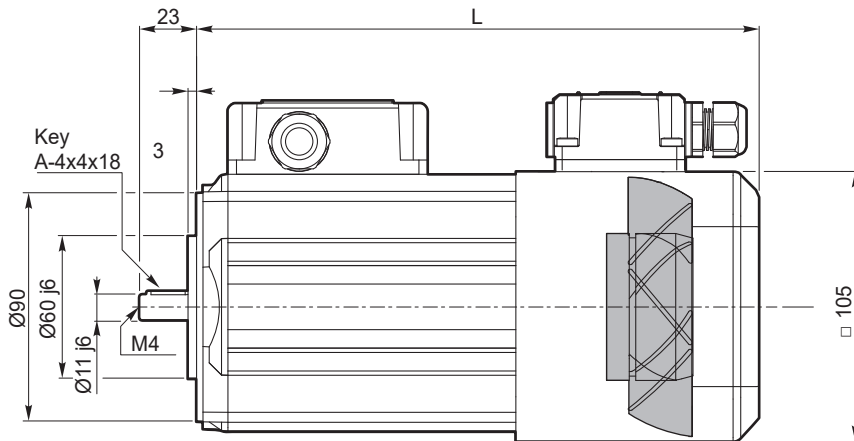

SMT	... SV	
	L	Kg
6324	210	5.0
6334	225	5.7
6344	250	6.8

3 ~

**SMT71.. - B14 - SV**

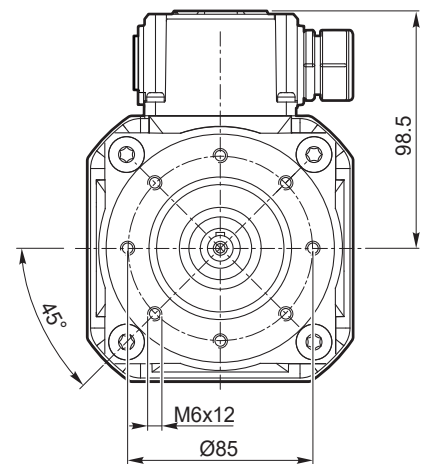
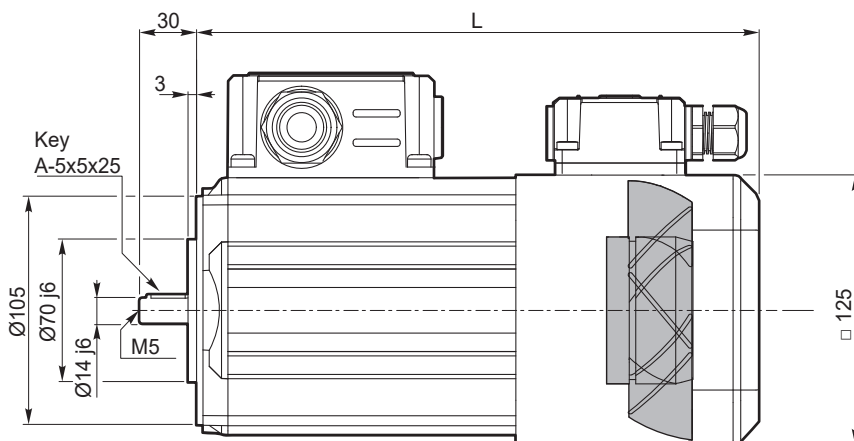

SMT	... SV	
	L	Kg
7124	219	7.5
7134	234	8.5
7144	259	10.2

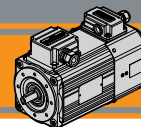

Opzione guarnizione CA

Rubber gasket option

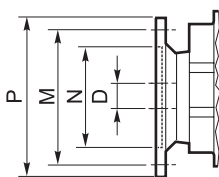
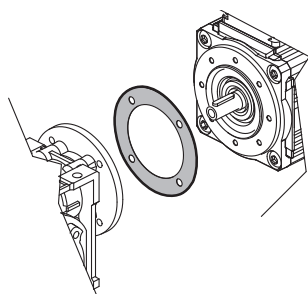

Dimensioni IEC / IEC Dimensions		
	63 B14	71 B14
N	60	70
M	75	85
P	90	105
D	11	14

Grado di protezione IP

IP protection rating

Indica il grado di isolamento meccanico del corpo motore.

IP protection rating indicates the degree of mechanical insulation of the motor casing.

1<sup>a</sup> cifra protezione alla penetrazione di corpi solidi.

The 1<sup>st</sup> figure indicates the level of protection against the intrusion of solid matter.

2<sup>a</sup> cifra protezione contro la penetrazione d'acqua.

The 2<sup>nd</sup> figure indicates to which degree the motor is waterproof.

IP		Definizione / Description	IP		Definizione / Description
0		Non protetto / No protection	0		Non protetto / No protection
1	 Ø 50 mm	Protetto da corpi solidi superiori a Ø 50 mm. Protected against solid matter (over Ø 50 mm).	1		Protetto contro la caduta verticale di gocce d'acqua. Protected against drops of water falling vertically.
2	 Ø 12 mm	Protetto da corpi solidi superiori a Ø 12 mm. Protected against solid matter (over Ø 12 mm).	2		Protetto contro la caduta verticale di gocce d'acqua con inclinazione max di 15°. Protected against drops of water falling up to 15°.
3	 Ø 2.5 mm	Protetto da corpi solidi superiori a Ø 2.5 mm. Protected against solid matter (over Ø 2.5 mm).	3		Protetto contro la pioggia. Rain proof.
4	 Ø 1 mm	Protetto da corpi solidi superiori a Ø 1 mm. Protected against solid matter (over Ø 1 mm).	4		Protetto contro gli spruzzi. Splash proof.
5		Protetto contro la polvere. Dust protected.	5		Protetto contro getti d'acqua. Water jet proof.
6		Totalmente protetto contro la polvere. Fully dust tight.	6		Protetto dalle ondate. Waveproof.
7		N.A.	7		Protetto contro immersione. Immersion up to 1 metre.
8		N.A.	8		Protetto contro immersione/sommersione prolungata. Immersion beyond 1 metre.

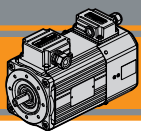

**Tipi di servizi IEC**

**IEC duty cycles**

Il servizio di un motore indica il tipo di utilizzo e la gravosità del ciclo di lavoro.

The duty cycle of a motor indicates its use and running cycle.

Grafico servizi più comuni

Most common duty cycles diagram

N = funzionamento / run  
R = riposo / rest

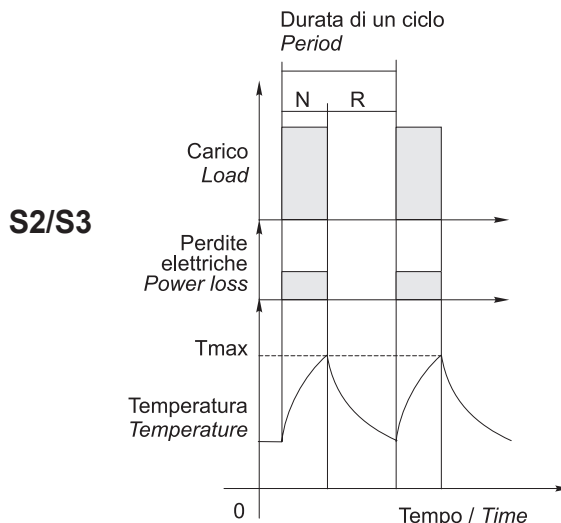
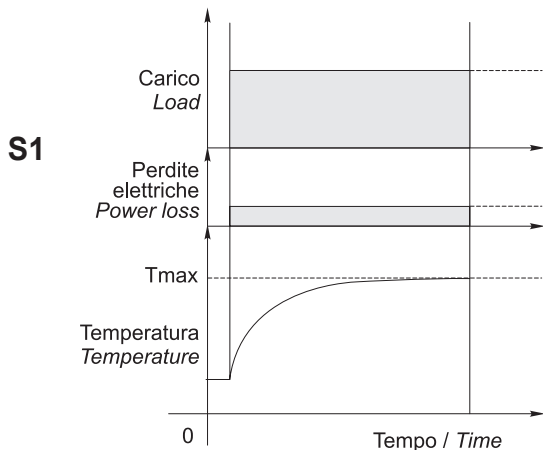

NOTA: Lo stesso motore può essere usato per cicli e servizi diversi, con l'unica limitazione che la temperatura interna non superi mai la Tmax stabilita dalla classe di isolamento termico del motore.

NOTE: The same motor can run under all duty services, limitation is due to internal temperature that must not override Tmax stated by motor thermal class.

**Classe di isolamento termico**

**Insulation class**

La classe termica indica il grado di resistenza alla temperatura interna, nel punto più caldo (avvolgimenti). Isolamento termico classe F.

Thermal insulation class indicates the level of thermal protection measured at the hottest point inside the motor (windings). Thermal insulation class F.

Classe Class	Massima temperatura interna Max. windings temp.
E	120°C
B	130°C
F	155°C
H	180°C

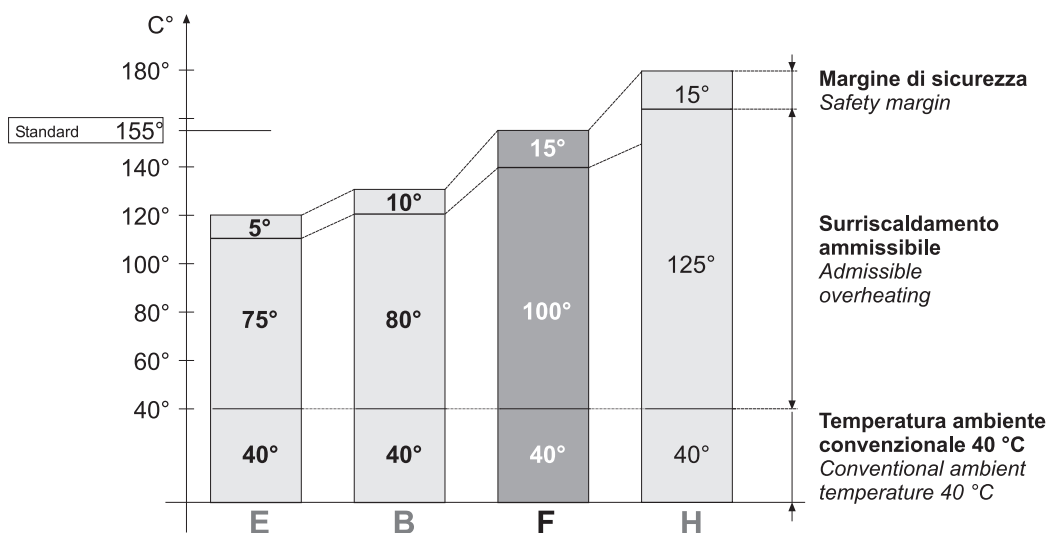

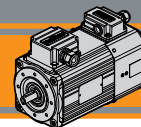

**Serie SM - Funzionamento a 60 Hz**

**Series SM - 60 Hz line power supply**

Velocità, coppia e potenza nominale nel funzionamento a 60 Hz varieranno come da tabella:

Speed, torque and rated power in 60 Hz operation is shown in the following table:

	50 Hz	60 Hz
<b>400 V</b>	Vedi dati tecnici / see technical data 	Velocità / speed $\approx + 20\%$ Coppia / torque $\approx -20\%$ Potenza / power $\approx$ invariata / the same
<b>480 V</b>	Non permesso / not allowed	Velocità / speed $\approx + 20\%$ Coppia / torque $\approx$ invariata / the same Potenza / power $\approx + 20\%$

AC

**Tabella pressacavi**

**Table of cable glands data**

**Serie SM..BR / SM..BR Series**

TAGLIA SIZE	Pressacavo Cable gland
63 / 71	1x M20x1.5

**Connessioni e collegamenti - Motore**

**Connection diagram - Motor**

Riferimenti

References

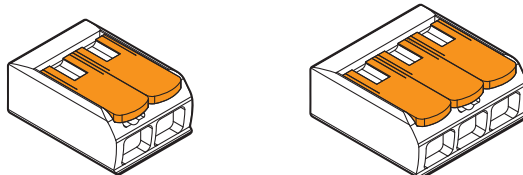

Morsetto di collegamento a leva a 2 e 3 poli  
Splicing connector with lever 2 - and 3 - pin.

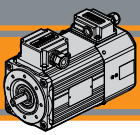

**Connessioni e collegamenti - Motore**

**Connection diagram - Motor**

**400/460 V - Trifase / three phase**

**Collegamento a stella / Star connection**

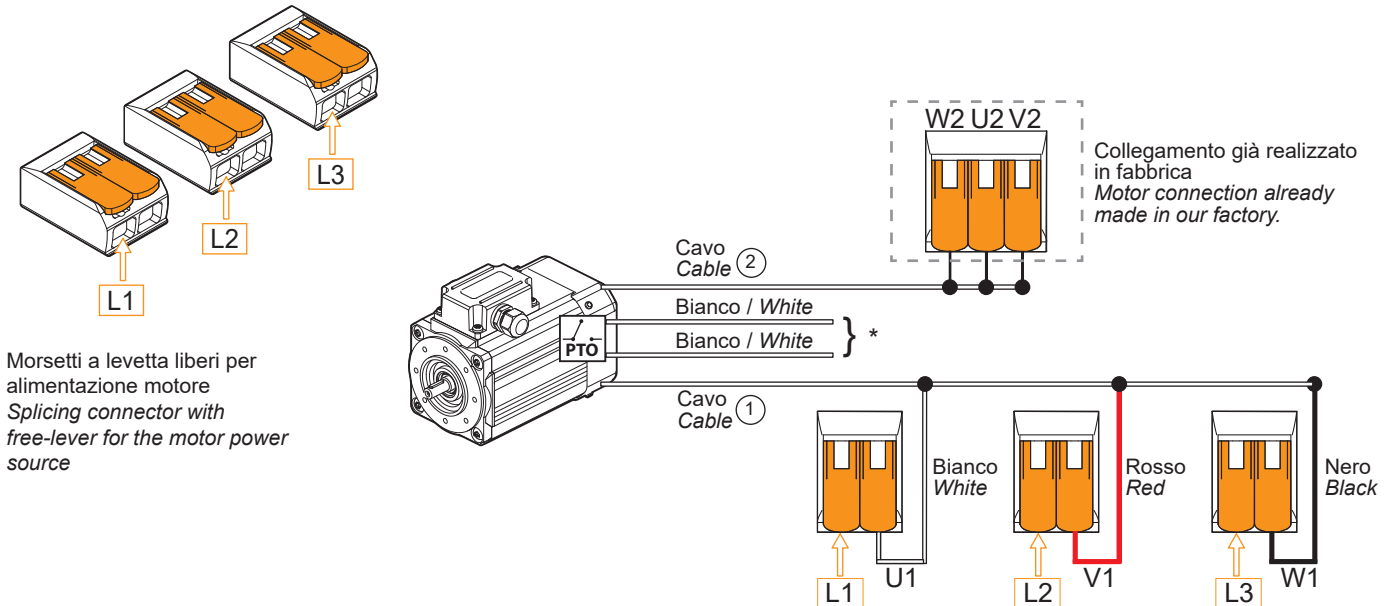

\*: collegamento al circuito di comando del motore a cura del cliente. Per ragioni di sicurezza è sconsigliato il collegamento in serie. Se necessario contattare il Servizio Tecnico Transtecno. PTO disponibile per taglie 56, 63, 71, 80, 90.  
 \*: motor supply connection by the customer. For safety reason Transtecno advises against PTO connected in series. If needed, contact Transtecno Technical Service. PTO is available for sizes 56, 63, 71, 80, 90.

**230 V - Trifase / three phase**

**Collegamento a triangolo / Delta connection**

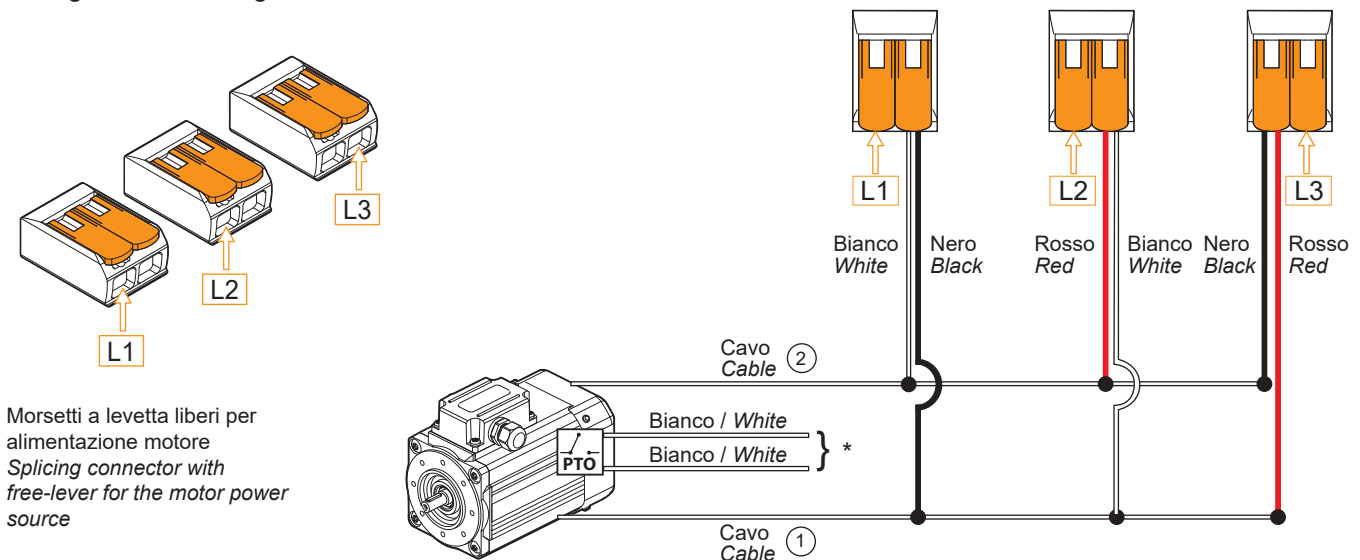

\*: collegamento al circuito di comando del motore a cura del cliente. Per ragioni di sicurezza è sconsigliato il collegamento in serie. Se necessario contattare il Servizio Tecnico Transtecno. PTO disponibile per taglie 56, 63, 71, 80, 90.  
 \*: motor supply connection by the customer. For safety reason Transtecno advises against PTO connected in series. If needed, contact Transtecno Technical Service. PTO is available for sizes 56, 63, 71, 80, 90.

I motori della serie SM sono forniti in collegamento a stella, lo schema di collegamento a triangolo sopra riportato fornisce una chiara indicazione delle modifiche che il cliente può apportare in autonomia. Se necessario contattare il Servizio Tecnico Transtecno.

*The SM series is supplied in star connection, the delta connection diagram shown above provides a clear indication of the modification that the customer can make independently. If needed, contact Transtecno Technical Service.*

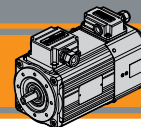

**Connessioni e collegamenti - Servoventola**

**Connection diagram - Servo fan**

Riferimenti

References

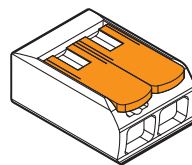
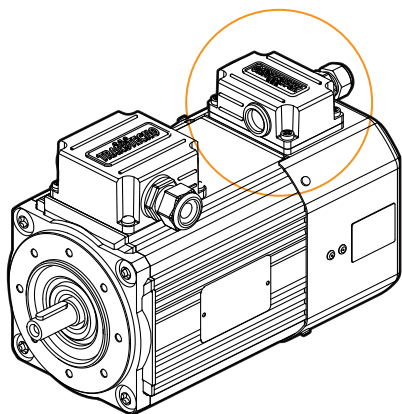

Morsetto di collegamento a leva a 2 poli  
Splicing connector with lever 2 pin.

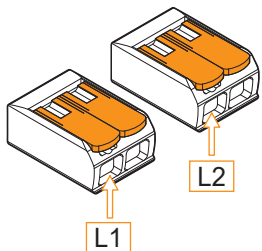

Morsetti a levetta liberi per alimentazione servoventola  
Splicing connector with free-lever for the electric fan

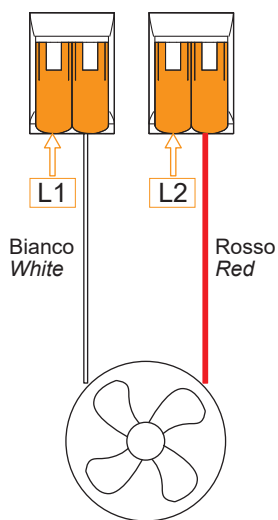

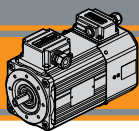

Targhetta

Nameplate

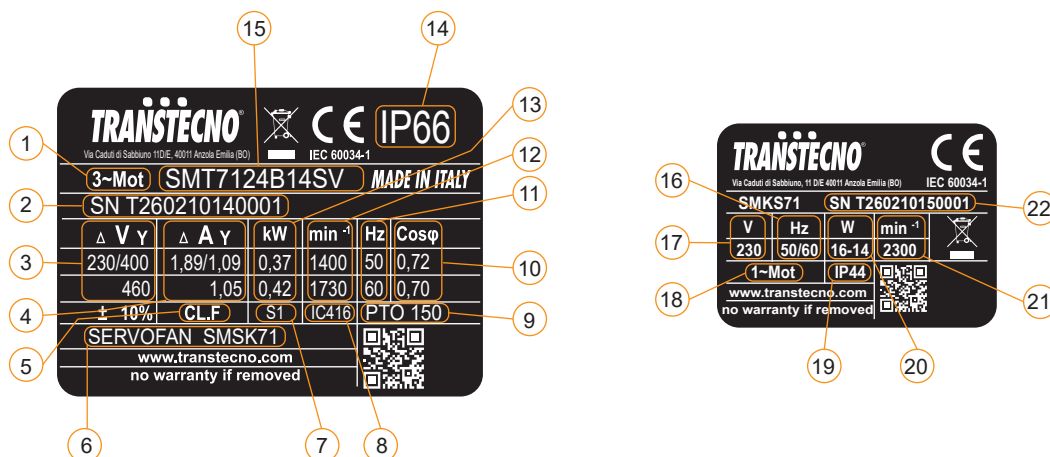

Pos.	Descrizione	Description
1	Tipo di alimentazione	Power supply
2	Numero di serie	Serial number
3	Tensione di alimentazione	Supply voltage
4	Corrente nominale	Rated current
5	Classe di isolamento	Insulation class
6	Tipo servoventola	Servo fan type
7	Servizio	Duty
8	Ventilazione	Fan cooling
9	Protezione termica PTO 150°C	PTO 150°C Thermal protection
10	Fattore di potenza	Power factor
11	Frequenza nominale	Rated frequency
12	Velocità nominale	Rated speed
13	Potenza nominale	Rated power
14	Grado di protezione IP motore	Motor IP protection rating
15	Tipo motore	Motor type
16	Frequenza kit servoventola	Servo fan kit frequency
17	Tensione kit servoventola	Servo fan kit voltage
18	Tipo di alimentazione kit servoventola	Servo fan kit power supply
19	Grado di protezione kit servoventola	Servo fan kit IP protection rating
20	Potenza kit servoventola	Servo fan kit power
21	Velocità kit servoventola	Servo fan kit speed
22	Numero di serie kit servoventola	Servo fan kit serial number

**MINI**  **TECNO**™  
**small** but strong

**SM..UL/CSA**



**Motori elettrici asincroni CA**  
**AC asynchronous electric motors**

**C**  **US**  
File E511911



**MINI**  **TECNO**™ brand of  
**TRANSTECNO**®



AC



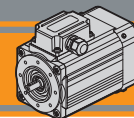

<b>Indice</b>	<b>Index</b>	Pag. Page
Caratteristiche tecniche	<i>Technical features</i>	<b>AD2</b>
Designazione	<i>Classification</i>	<b>AD2</b>
Simbologia e formule	<i>Symbols and formulas</i>	<b>AD3</b>
Dati tecnici	<i>Technical data</i>	<b>AD3</b>
Dimensioni motori trifase	<i>Three phase motors dimensions</i>	<b>AD4</b>
Dimensioni motori monofase	<i>Single phase motors dimensions</i>	<b>AD7</b>
Cava esagonale	<i>Hexagonal socket</i>	<b>AD8</b>
Versioni opzionali	<i>Optional versions</i>	<b>AD8</b>
Opzione guarnizione CA	<i>Rubber gasket option</i>	<b>AD8</b>
Certificazione UL / CSA	<i>UL / CSA certificate</i>	<b>AD8</b>
Gradi di protezione IP	<i>IP protection rating</i>	<b>AD9</b>
Tipo di servizio IEC	<i>IEC duty cycles</i>	<b>AD10</b>
Tabella pressacavi	<i>Table of cable glands data</i>	<b>AD10</b>
Connessioni e collegamenti	<i>Connection diagram</i>	<b>AD11</b>
Targhetta	<i>Nameplate</i>	<b>AD13</b>

Questa sezione annulla e sostituisce ogni precedente edizione o revisione. Qualora questa sezione non Vi sia giunta in distribuzione controllata, l'aggiornamento dei dati ivi contenuto non è assicurato. **In tal caso la versione più aggiornata è disponibile sul nostro sito internet [www.transtecno.com](http://www.transtecno.com)**

*This section replaces any previous edition and revision. If you obtained this catalogue other than through controlled distribution channels, the most up to date content is not guaranteed. In this case the latest version is available on our web site [www.transtecno.com](http://www.transtecno.com)*

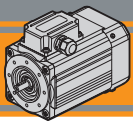

**Caratteristiche tecniche**

**Technical characteristics**

I motori certificati UL/CSA delle serie SMT ed SMM hanno le seguenti caratteristiche principali:

SMT and SMM motor range with UL/CSA Certification has the following main features:

- Costruzione compatta
- Motorizzazioni in corrente alternata monofase e trifase
- Carcassa estrusa in alluminio anodizzato nero
- Motore elettrico AC con grado di protezione IP66 (escluso condensatore)
- Rumorosità e vibrazioni contenute
- Isolamento termico di classe F
- Flangia motore IEC B14
- Temperatura ambiente: -20°C/+40°C
- Disponibili nella versione ventilata TEFC (servizio S1).
- Protezione termica PTO 150°C
- Motori trifase SMT dotati di separatori di fase
- Cava esagonale su albero motore lato NDE
- Condensatore di marcia per motori monofase SMM
- La tolleranza di tensione è ±10%
- Standard applicati:  
UL1004-1: Rotating Electrical Machines General Requirements  
CSA:100-14: Motors and Generators

- Compact design
- AC single phase and three phase motors available
- Black anodized extruded aluminium housing
- AC electric motor in IP66 protection Standard (except capacitor)
- Low noise and vibrations
- Class F insulation Standard
- Motor flange IEC B14
- Ambient temperature: -20°C / +40°C
- Fan cooled TEFC (duty S1)
- PTO 150°C thermal protection
- Three phase motors SMT equipped with phase separators.
- Motor shaft hexagon socket on the NDE side.
- Running capacitor for single phase motors SMM.
- Voltage tolerance ±10%
- Standards applied:  
UL1004-1: Rotating Electrical Machines General Requirements  
CSA:100-14: Motors and Generators

**SM .. TEFC**

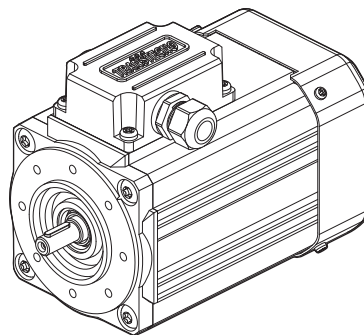





**CU** US  
File E511911



**Designazione**

**Classification**

MOTORE TRIFASE / THREE PHASE MOTOR									
SMT	63	2	4	0.18 kW	B14	230-400 V	50 Hz	TEFC	UL-CSA
Tipo Type	Grandezza Size	Indicativo potenza Power coefficient	Poli Poles	Potenza Power	Forma costruttiva Version	Tensione Voltage	Frequenza Frequency	Ventilazione Fan cooling	Versione UL UL Version
<b>SMT</b>	Vedi tabelle See tables	<b>2 - 3</b>	<b>4</b>	<b>0.09 kW</b> ... <b>0.66 kW</b>	<b>B14</b>	<b>230-400 V</b>  <b>460V</b>	<b>50Hz</b>  <b>60Hz</b>	<b>TEFC</b>	<b>UL-CSA</b>
									
									

MOTORE MONOFASE / SINGLE PHASE MOTOR									
SMM	63	2	4	0.18 kW	B14	115 V	60 Hz	TEFC	UL-CSA
Tipo Type	Grandezza Size	Indicativo potenza Power coefficient	Poli Poles	Potenza Power	Forma costruttiva Version	Tensione Voltage	Frequenza Frequency	Ventilazione Fan cooling	Versione UL UL Version
<b>SMM</b>	Vedi tabelle See tables	<b>2 - 3</b>	<b>4</b>	<b>0.09 kW</b> ... <b>0.37 kW</b>	<b>B14</b>	<b>115V</b>	<b>60Hz</b>	<b>TEFC</b>	<b>UL-CSA</b>
									
									

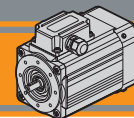
**Simbologia e formule**
**Symbols and formulas**

$P_n$	[kW]	Potenza nominale	Rated power
$I_n$	[A]	Corrente nominale	Rated current
$M_n$	[Nm]	Coppia nominale	Rated torque
$n_n$	[rpm]	Velocità nominale	Rated speed
$M_s / M_n$		Rapporto coppia spunto / coppia nominale	Ratio start torque / rated torque
$M_k / M_n$		Rapporto coppia massima / coppia nominale	Ratio max torque / rated torque
$I_s / I_n$		Rapporto corrente di spunto / corrente nominale	Ratio start current / rated current
$\cos\varphi$		Fattore di potenza al carico nominale	Power factor at rated torque load
$\eta$		Rendimento al carico nominale	Efficiency at rated torque load
$f$	[Hz]	Frequenza	Frequency
$V$	[V]	Tensione	Voltage
Potenza Power	[HP]	Potenza [kW] x 1.341	Power [kW] x 1.341
Potenza resa $P_n$ $P_n$ output power	[kW]	Potenza assorbita x $\eta$	Absorbed power x $\eta$
Pot. assorbita Absorbed power	[kW]	$\frac{V \times I \times \cos\varphi}{1000}$ (monofase)	$\frac{V \times I \times \cos\varphi}{1000}$ (singlephase)
		$\frac{V \times I \times \sqrt{3} \times \cos\varphi}{1000}$ (trifase)	$\frac{V \times I \times \sqrt{3} \times \cos\varphi}{1000}$ (threephase)
$I_n$ (230 V)		$I_n$ (400 V) x $\sqrt{3}$	$I_n$ (400 V) x $\sqrt{3}$

**Dati tecnici**
**Technical data**
**SMT Motori trifase / SMT Three phase motors**

 (230-400 V / 50 Hz) poli / poles **4**

 (460 V / 60 Hz) poli / poles **4**

TAGLIA SIZE	$P_n$ [kW]	$M_n$ [Nm]	$n_n$ [min <sup>-1</sup> ]	V - f [V - Hz]	$I_n$ (400-460 V) [A]	$\eta$ %	$\cos\varphi$	$M_s/M_n$	$I_s/I_n$	$M_k/M_n$	PTO [°C]	Servizio Duty TEFC
5624	0.09	0.63	1365	400 - 50	0.45	47.3	0.61	2.50	2.40	2.70	PTO 150°	S1
	0.11		1660	460 - 60		50.3		2.60	2.60			
5634	0.12	0.88	1300	400 - 50	0.45	52.0	0.74	1.90	2.40	1.90		
	0.14	0.83	1600	460 - 60	0.42	59.0	0.71	2.10	2.70	2.10		
6324	0.18	1.26	1360	400 - 50	0.69	57.0	0.66	2.50	2.90	2.50		
	0.22	1.27	1650	460 - 60		59.7	0.67		3.00			
6334	0.25	1.74	1375	400 - 50	0.94	62.0	0.64	2.80	3.00	2.80		
	0.28	1.59	1690	460 - 60		61.3	0.61	3.00	3.20	3.00		
7124	0.37	2.52	1400	400 - 50	1.09	68.0	0.72	2.75	4.20	2.75		
	0.42	2.35	1700	460 - 60		68.1	0.71	2.90	4.50	2.90		
7134	0.55	3.76	1395	400 - 50	1.55	70.2	0.73	2.90	4.40	2.90		
	0.66	3.71	1700	460 - 60		73.2			4.80	2.80		

**SMM Motori monofase / SMM Single phase motors**

 (115 V / 60 Hz) poli / poles **4**

TAGLIA SIZE	$P_n$ [kW]	$M_n$ [Nm]	$n_n$ [min <sup>-1</sup> ]	V - f [V - Hz]	$I_n$ (115V) [A]	$\eta$ %	$\cos\varphi$	$M_s/M_n$	$I_s/I_n$	$M_k/M_n$	Cond/cap [μF]	PTO [°C]	Servizio Duty TEFC
5624	0.09	0.52	1665	115 - 60	1.60	50.0	0.98	0.64	1.95	1.51	20	PTO 150°	S1
6324	0.18	1.09	1570	115 - 60	2.70	58.5	0.99	1.0	2.1	1.50	40		
7124	0.37	2.18	1620	115 - 60	4.70	69.8	0.98	0.64	2.3	1.33	60		

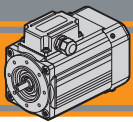

Dimensioni motori trifase

Three phase motors dimensions

3 ~

**SMT56.. - B14 - TEFC**

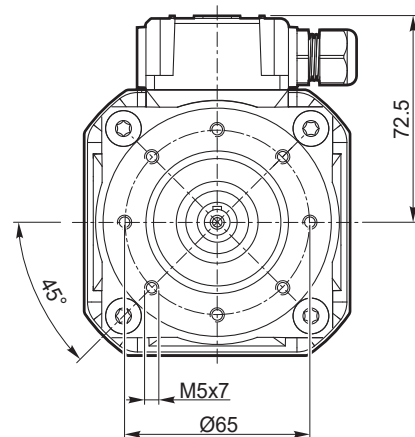
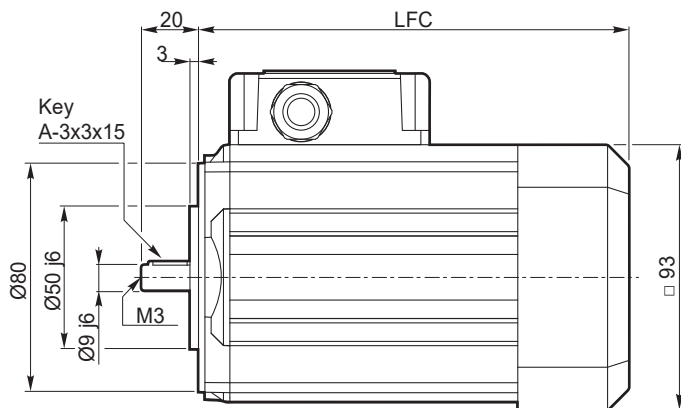

SMT	... TEFC	
	LFC	Kg
5624	186	3.1
5634	186	3.5

3 ~

**SMT63.. - B14 - TEFC**

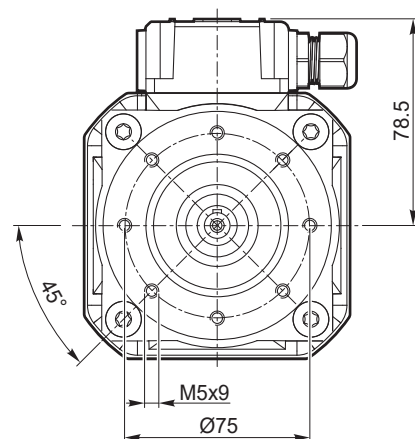
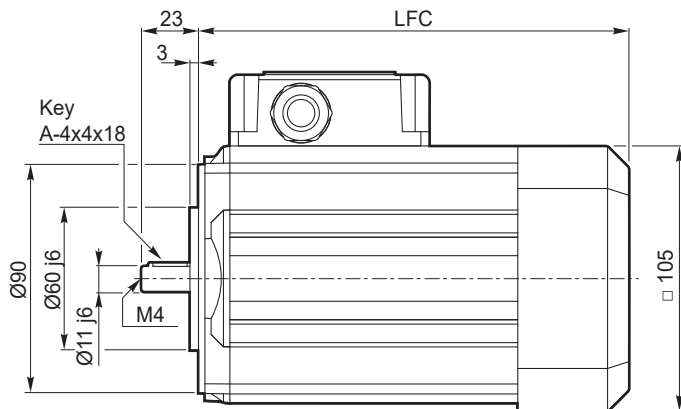

SMT	... TEFC	
	LFC	Kg
6324	205.5	4.7
6334	205.5	5.4

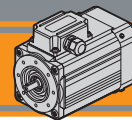



Dimensioni motori trifase

Three phase motors dimensions

3 ~

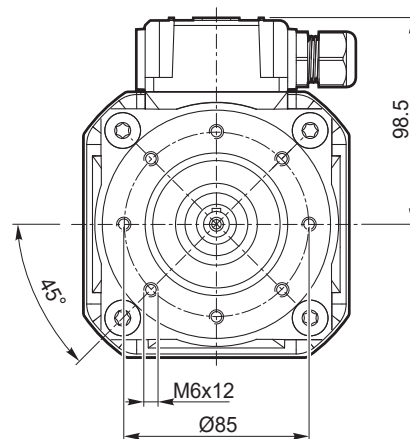
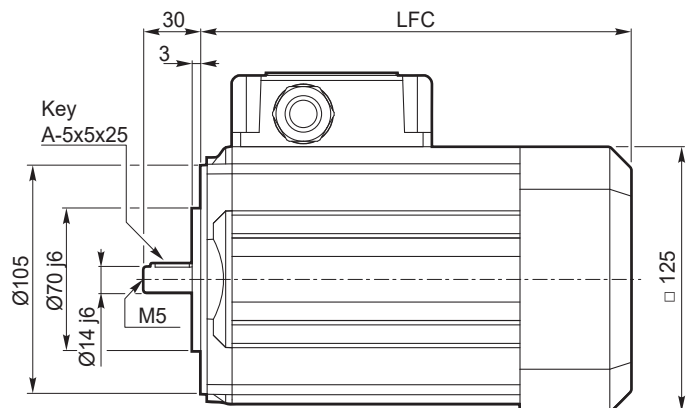
SMT71.. - B14 - TEFC



SMT	... TEFC	
	LFC	 Kg
7124	214	7.0
7134	214	8.2

AC

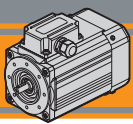

Dimensioni motori monofase

Single phase motors dimensions

1 ~

**SMM56.. - B14 - TEFC**

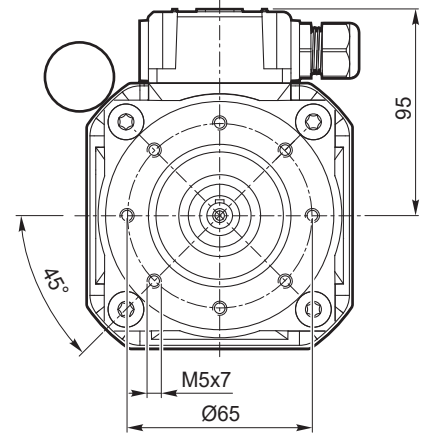
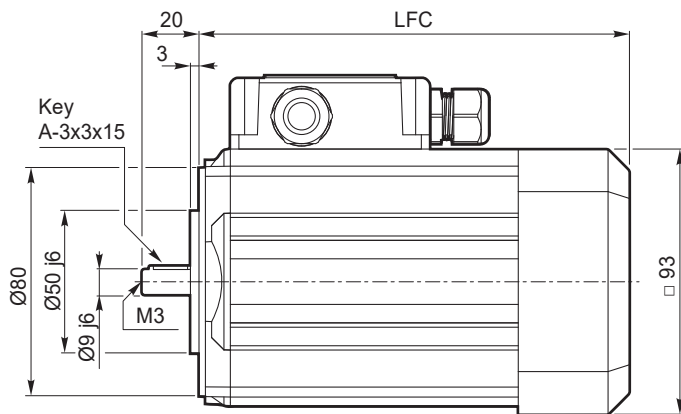

SMM	... TEFC	
	LFC	Kg
5624	186	3.6

1 ~

**SMM63.. - B14 - TEFC**

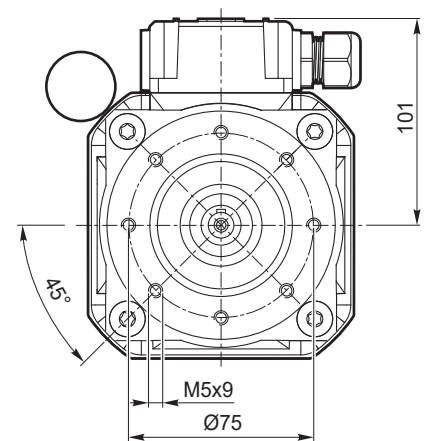
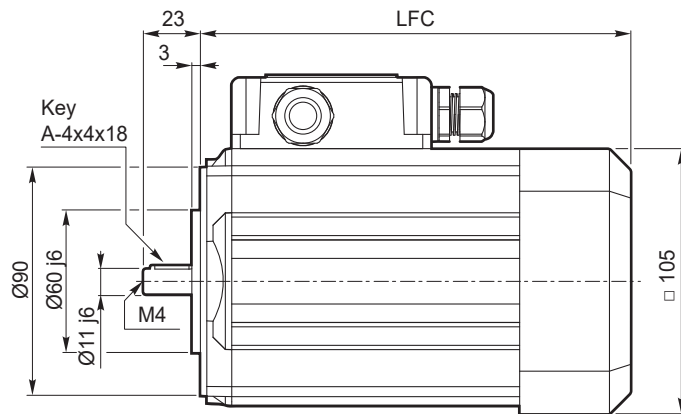

SMM	... TEFC	
	LFC	Kg
6324	205.5	5.5

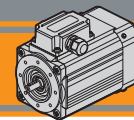

Dimensioni motori monofase

Single phase motors dimensions

1 ~

**SMM71.. - B14 - TEFC**

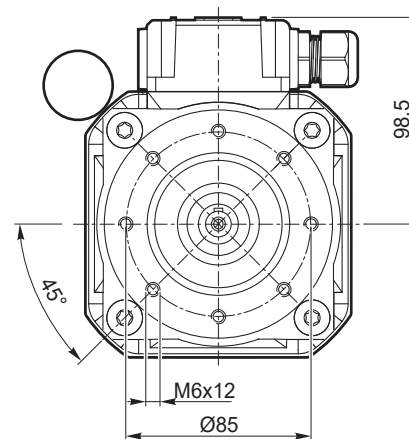
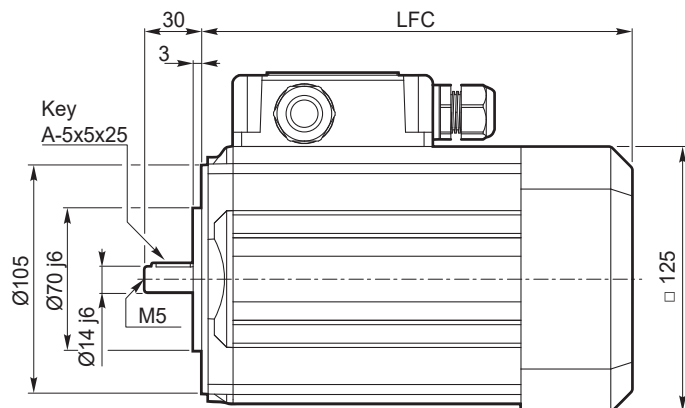

SMM	... TEFC	
	LFC	kg
7124	214	8.0

AC

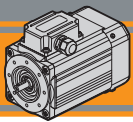

**Cava esagonale**

**Hexagonal socket**

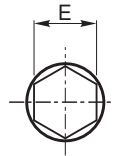
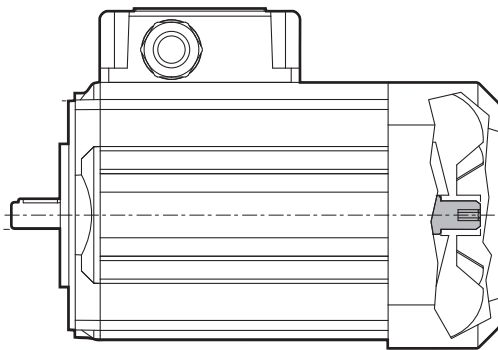

**Esagono / Hexagon**

SM..	E
56	4
63	4
71	6

**Nota:**

Installare a monte dell'alimentazione un dispositivo che assicuri la disconnessione della rete omipolare, durante le operazioni di rotazione manuale è obbligatorio l'utilizzo di tale sezionatore.

Il quadro elettrico del motore deve essere lucchettabile al fine di evitare il riarmo non previsto alla rete elettrica.

E' severamente vietata la messa in servizio del motore elettrico senza copriventola opportunamente montata.

**Note:**

*An omnipolar cut-off device must be fitted upstream of the power supply; the use of this device is mandatory during manual rotation operations.*

*The switchgear for the motor must be padlockable in order to prevent the power supply from being accidentally reset. It is strictly prohibited to put the electric motor into service if the fan cover is not fitted.*

**Opzione guarnizione CA**

**Rubber gasket option**

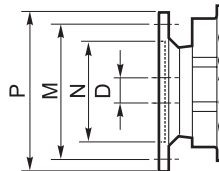
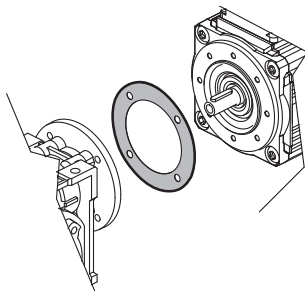

**Dimensioni IEC / IEC Dimensions**

	56 B14	63 B14	71 B14
<b>N</b>	50	60	70
<b>M</b>	65	75	85
<b>P</b>	80	90	105
<b>D</b>	9	11	14

**Versioni opzionali**

**Optional versions**

Versioni opzionali con freno ed encoder disponibili a richiesta su alcuni modelli. Su richiesta sono disponibili grandezze motore superiori a quelle indicate a catalogo.

Si prega di contattare il nostro Servizio Tecnico.

*Optional versions with brake and encoder are available on request on some models. Motor sizes bigger than those indicated in the catalogue are available on request.*

*Please contact our Technical Service.*

**Certificazione UL / CSA**

**UL / CSA certificate**

I motori SM certificati UL/CSA sono marcati secondo la Norma UL 1004-1, Rotating Electrical Machines General Requirements e CSA 100-14, Motors and Generators.

*SM motors Certified UL/CSA are marked for approval by UL 1004-1, Rotating Electrical Machines General Requirements and CSA 100-14, Motors and Generators.*

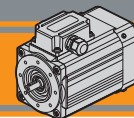
**Grado di protezione IP**
**IP protection rating**

Indica il grado di isolamento meccanico del corpo motore.

1<sup>a</sup> cifra protezione alla penetrazione di corpi solidi.

2<sup>a</sup> cifra protezione contro la penetrazione d'acqua.

IP protection rating indicates the degree of mechanical insulation of the motor casing.

The 1<sup>st</sup> figure indicates the level of protection against the intrusion of solid matter.

The 2<sup>nd</sup> figure indicates to which degree the motor is waterproof.

IP		Definizione / Description	IP		Definizione / Description
0		Non protetto / No protection	0		Non protetto / No protection
1		Protetto da corpi solidi superiori a Ø 50 mm. Protected against solid matter (over Ø 50 mm).	1		Protetto contro la caduta verticale di gocce d'acqua. Protected against drops of water falling vertically.
2		Protetto da corpi solidi superiori a Ø 12 mm. Protected against solid matter (over Ø 12 mm).	2		Protetto contro la caduta verticale di gocce d'acqua con inclinazione max di 15°. Protected against drops of water falling up to 15°.
3		Protetto da corpi solidi superiori a Ø 2.5 mm. Protected against solid matter (over Ø 2.5 mm).	3		Protetto contro la pioggia. Rain proof.
4		Protetto da corpi solidi superiori a Ø 1 mm. Protected against solid matter (over Ø 1 mm).	4		Protetto contro gli spruzzi. Splash proof.
5		Protetto contro la polvere. Dust protected.	5		Protetto contro getti d'acqua. Water jet proof.
6		Totalmente protetto contro la polvere. Fully dust tight.	6		Protetto dalle ondate. Waveproof.
7		N.A.	7		Protetto contro immersione. Immersion up to 1 metre.
8		N.A.	8		Protetto contro immersione/sommersione prolungata. Immersion beyond 1 metre.

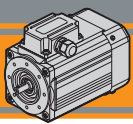

**Tipi di servizi IEC**

**IEC duty cycles**

Il servizio di un motore indica il tipo di utilizzo e la gravosità del ciclo di lavoro.

The duty cycle of a motor indicates its use and running cycle.

Grafico servizi più comuni

Most common duty cycles diagram

N = funzionamento / run  
R = riposo / rest

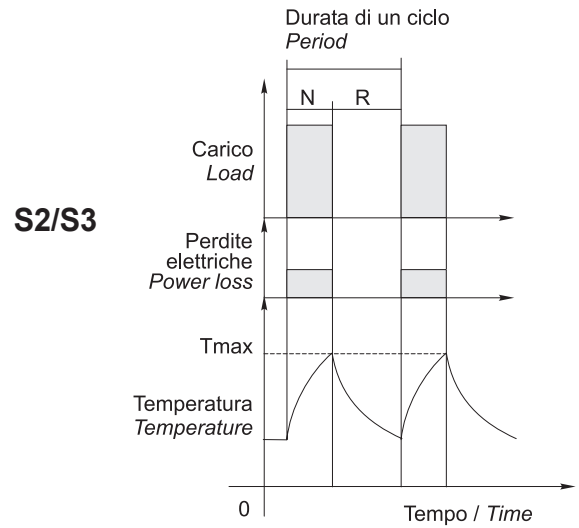
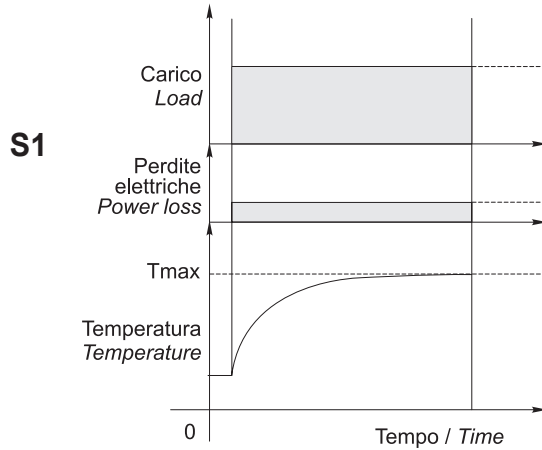

NOTA: Lo stesso motore può essere usato per cicli e servizi diversi, con l'unica limitazione che la temperatura interna non superi mai la T<sub>max</sub> stabilita dalla classe di isolamento termico del motore.

NOTE: The same motor can run under all duty services, limitation is due to internal temperature that must not override T<sub>max</sub> stated by motor thermal class.

**Tabella pressacavi**

**Table of cable glands data**

**Serie SMT / SMT Series**

TAGLIA SIZE	Pressacavo Cable gland
56 / 63	M16x1.5
71	M20x1.5

**Serie SMM / SMM Series**

TAGLIA SIZE	Pressacavo Cable gland
56 / 63	2 x M16x1.5
71	1x M20x1.5 + 1 x M16x1.5

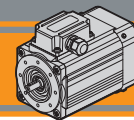

Connessioni e collegamenti

Connection diagram

Riferimenti

References

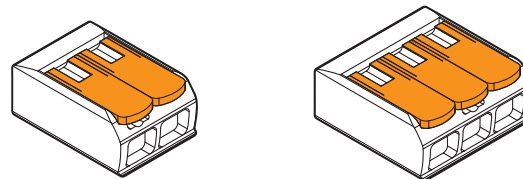
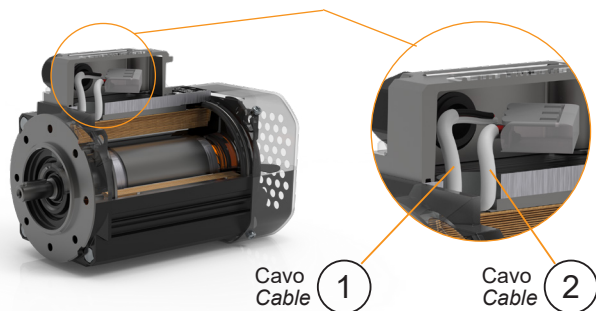

Morsetto di collegamento a leva a 2 e 3 poli  
Splicing connector with lever 2- and 3-pin.

400/460 V - Trifase / three phase

Collegamento a stella / Star connection

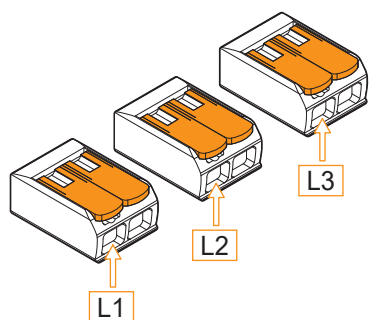

Morsetti a levetta liberi per alimentazione motore  
Splicing connector with free-lever for the motor power source

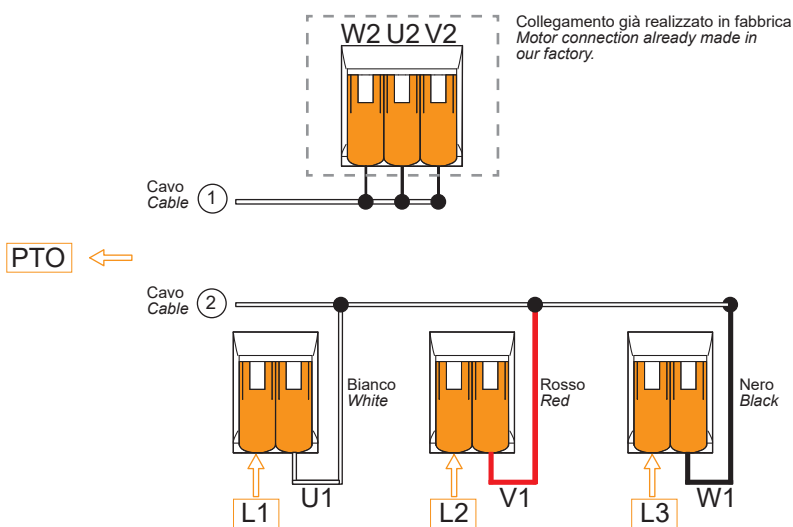

230 V - Trifase / three phase

Collegamento a triangolo / Delta connection

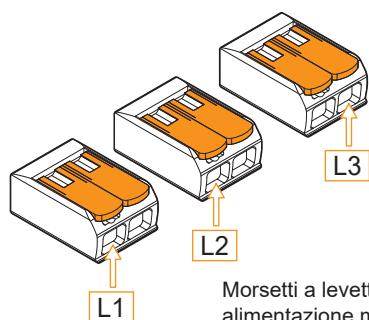

Morsetti a levetta liberi per alimentazione motore

Splicing connector with free-lever for the motor power source

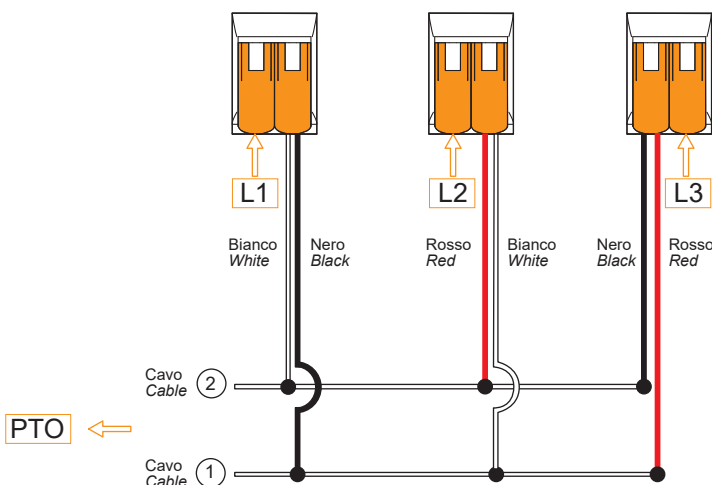

I motori della serie SM sono forniti in collegamento a stella, lo schema di collegamento a triangolo sopra riportato fornisce una chiara indicazione delle modifiche che il cliente può apportare in autonomia. Senecessario contattare il Serziario Tecnico Transtecno.

The SM series is supplied in star connection, the delta connection diagram shown above provides a clear indication of the modification that the customer can make independently. If needed, contact Transtecno Technical Service.

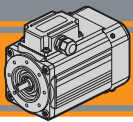

**Connessioni e collegamenti**

**Connection diagram**

**115 V - Monofase / single phase**

Monofase da SMM 56... a SMM 71... / Single phase from SMM 56... to SMM 71...

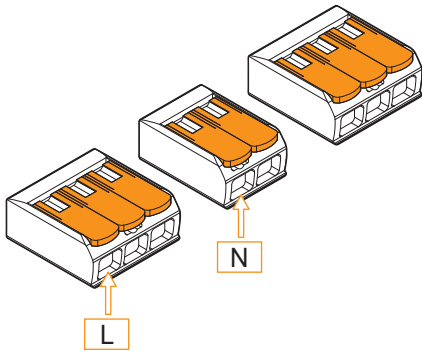

Morsetti a levetta liberi per alimentazione motore  
Splicing connector with free-lever for the motor power source

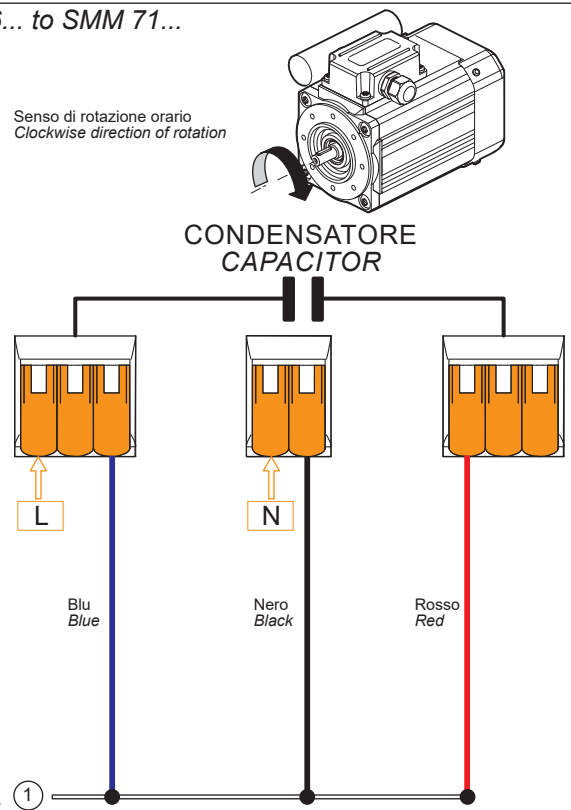

**115 V - Monofase / single phase**

Monofase da SMM 56... a SMM 71... / Single phase from SMM 56... to SMM 71...

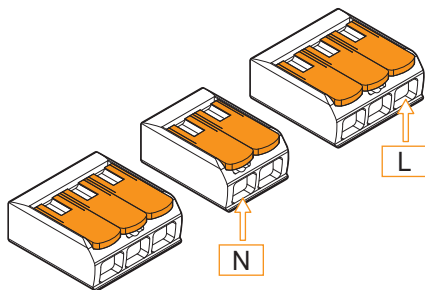

Morsetti a levetta liberi per alimentazione motore

Splicing connector with free-lever for the motor power source

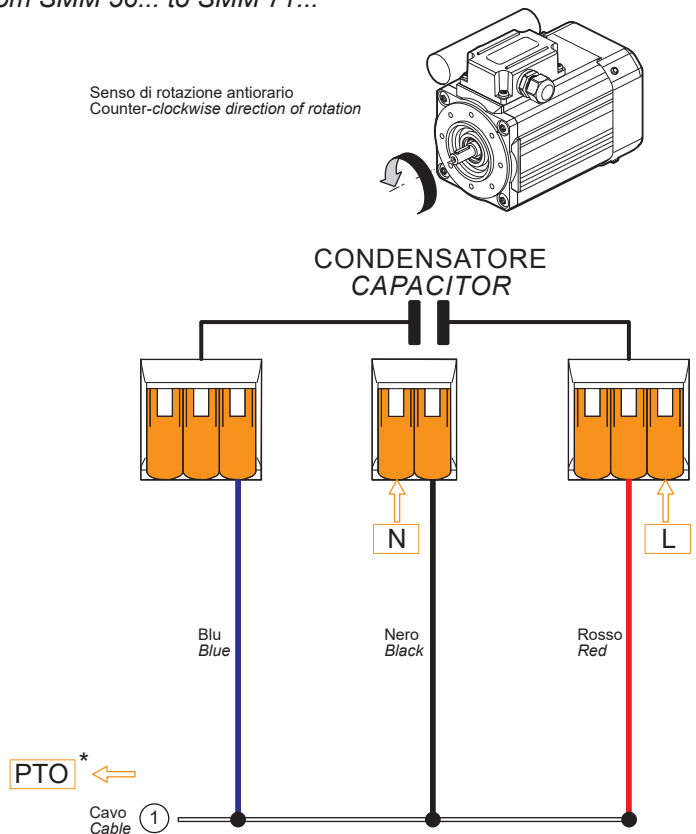

\*: collegamento al circuito di comando del motore a cura del cliente. Per ragioni di sicurezza è sconsigliato il collegamento in serie. Se necessario contattare il Servizio Tecnico Transtecno.

\*: motor supply connection by the customer. For safety reason Transtecno advises against PTO connected in series. If needed, contact Transtecno Technical Service.

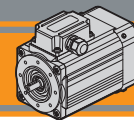
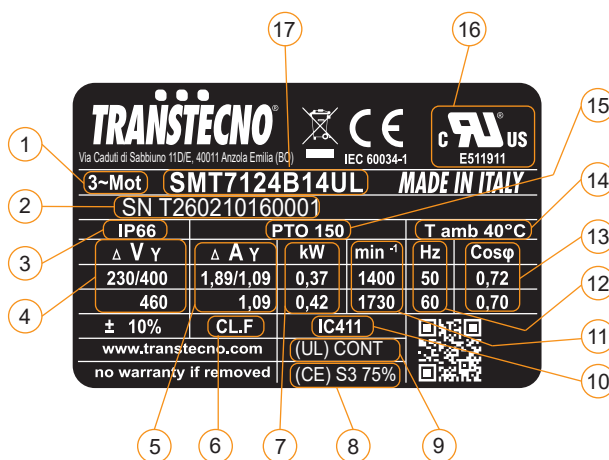
**Targhetta**
**Nameplate**

Pos.	Descrizione	Description
1	Tipo di alimentazione	Power supply
2	Numero di serie	Serial number
3	Grado di protezione IP motore	Motor IP protection rating
4	Tensione di alimentazione	Supply voltage
5	Corrente nominale	Rated current
6	Classe di isolamento	Insulation class
7	Potenza nominale	Rated power
8	Servizio per certificazione CE	CE compliance duty
9	Servizio per certificazione UL/CSA	UL/CSA compliance duty
10	Ventilazione	Fan cooling
11	Velocità nominale	Rated speed
12	Frequenza nominale	Rated frequency
13	Fattore di potenza	Power factor
14	Temperatura ambiente massima	Max allowed ambient temperature
15	Protezione termica PTO 150°C	PTO 150°C Thermal protection
16	Certificazione UL/CSA	UL/CSA compliance
17	Tipo di motore	Motor type



**MINI**  **TECNO**™  
**small** but strong

**CMG**

AC

## Motoriduttori CA ad ingranaggi cilindrici AC Helical in-line gearmotors



**MINI**  **TECNO**™ brand of  
**TRANSTECNO**®





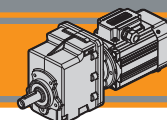

<b>Indice</b>	<b>Index</b>	Pag. Page
Caratteristiche tecniche	<i>Technical features</i>	<b>AE2</b>
Designazione	<i>Classification</i>	<b>AE2</b>
Sensi di rotazione	<i>Direction of rotation</i>	<b>AE3</b>
Lubrificazione	<i>Lubrication</i>	<b>AE3</b>
Simbologia	<i>Symbols</i>	<b>AE3</b>
Carichi radiali	<i>Radial loads</i>	<b>AE3</b>
Motori applicabili	<i>IEC Motor adapters</i>	<b>AE4</b>
Dati tecnici	<i>Technical data</i>	<b>AE4</b>
Dimensioni	<i>Dimensions</i>	<b>AE6</b>

Questa sezione annulla e sostituisce ogni precedente edizione o revisione. Qualora questa sezione non Vi sia giunta in distribuzione controllata, l'aggiornamento dei dati ivi contenuto non è assicurato. **In tal caso la versione più aggiornata è disponibile sul nostro sito internet [www.transtecno.com](http://www.transtecno.com)**

*This section replaces any previous edition and revision. If you obtained this catalogue other than through controlled distribution channels, the most up to date content is not guaranteed. In this case the latest version is available on our web site [www.transtecno.com](http://www.transtecno.com)*

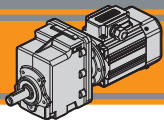

**Caratteristiche tecniche**

**Technical features**

Le caratteristiche principali dei motoriduttori CMG sono:

CMG gearmotor range has the following main features:

- Costruzione compatta
- Motorizzazioni in corrente alternata monofase e trifase
- Carcassa motore estrusa in alluminio anodizzato nero
- Carcasse dei riduttori in pressofusione di alluminio
- Motore elettrico AC con grado di protezione IP66
- Lubrificazione permanente con olio sintetico
- Ingranaggi cilindrici a denti elicoidali, induriti e rettificati
- Disponibili sia nella versione ventilata TEFC (servizio S1) che non ventilata TENV (servizio S3)
- Protezione termica PTO 150°C per le taglie motore 56, 63 e 71.
- SMT56, SMT63 e SMT71 adatti al funzionamento con alimentazione da inverter
- Disponibili nelle versioni autofrenante, servovenilata e con certificazione UL.
- Disponibili con giunto elastico in entrata

- Compact design
- AC single phase and three phase motors available
- Motor extruded aluminum housing black anodized
- Gearbox die-cast aluminum housing
- AC electric motor in IP66 protection Standard
- Permanent synthetic oil long-life lubrication
- Ground-hardened helical gears
- Fan cooled TEFC (duty S1) and not ventilated TENV (duty S3) versions available
- PTO 150°C thermal protection for motor sizes 56, 63 and 71.
- SMT56, SMT63 and SMT71 are suitable for inverter duty
- Brake motors, forced ventilation motors and UL compliance versions available.
- Available with input flexible couplin

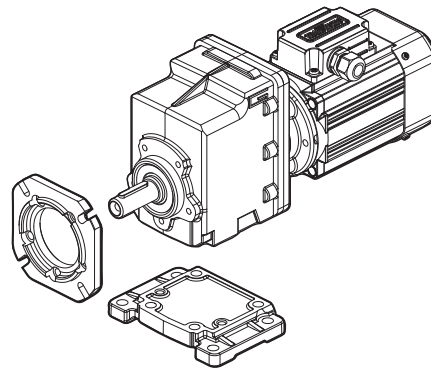

**Designazione**

**Classification**

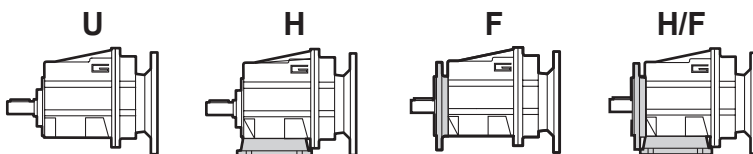

RIDUTTORE / GEARBOX

CMG	00	2	H60	10.16	D20	63	B14	FX
Tipo Type	Grandezza Size	Stadi Stages	Versione Version	Rapporto Ratio	Albero uscita Output shaft	IEC 	Forma costruttiva Version	Giunto elastico Flexible coupling
<b>CMG</b>	<b>00</b>	<b>2</b> <b>3</b>	<b>U...</b> <b>H...</b> <b>F...</b> <b>H.../F...</b>	vedi tabelle see tables	vedi tabelle see tables	<b>56..</b> <b>63..</b> <b>71..</b>	<b>B14</b>	<b>FX</b> 

MOTORE TRIFASE / THREE PHASE MOTOR

SMT	63	2	4	0.18 kW	B14	230-400 V	50 Hz	TEFC	BR	T1
Tipo Type	Grandezza Size	Indicativo potenza Power coefficient	Poli Poles	Potenza Power	Forma costruttiva Version	Tensione Voltage	Frequenza Frequency	Ventilazione Fan cooling	Opzioni Options	Pos. Morsetti Terminal box pos.
<b>SMT</b> 	Vedere tab. See tab.	<b>1-2-3-4-5</b>	<b>4</b>	<b>0.04 kW</b> ... <b>0.75 kW</b>	<b>B14</b>	<b>230-400 V</b>  <b>460V</b>	<b>50Hz</b>  <b>60Hz</b>	<b>TEFC</b>  <b>TENV</b>		<b>T1 (Std)</b> 

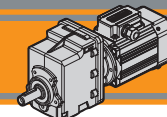

MOTORE MONOFASE / SINGLE PHASE MOTOR										
SMM	63	2	4	0.18 kW	B14	230 V	50 Hz	TEFC	UL-CSA	T1
Tipo Type	Grandezza Size	Indicativo potenza Power coefficient	Poli Poles	Potenza Power	Forma costruttiva Version	Tensione Voltage	Frequenza Frequency	Ventilazione Fan cooling	Opzioni Options	Pos. Morsettiera Terminal box pos.
<b>SMM</b>	Vedere tab. See tab.	<b>1-2-3-4</b>	<b>4</b>	<b>0.04 kW</b> ... <b>0.55 kW</b>	<b>B14</b>	<b>230V</b>	<b>50Hz</b>	<b>TEFC</b>  <b>TENV</b>	<b>AD1</b>	T1 (Std) T4 T2 T3

**Sensi di rotazione**

**Direction of rotation**

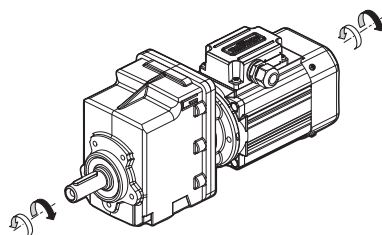

**Lubrificazione**

**Lubrication**

Tutti i riduttori sono forniti completi di lubrificante sintetico viscosità 320, pertanto possono essere installati in qualunque posizione di montaggio e non necessitano di manutenzione.

Permanent synthetic oil long-life lubrication ( viscosity grade 320) makes it possible to use in all mounting positions; for this reason they can be installed in any assembly position and do not require maintenance.

**Simbologia**

**Symbols**

- $n_1$  [min<sup>-1</sup>] Velocità in ingresso / Input speed
- $n_2$  [min<sup>-1</sup>] Velocità in uscita / Output speed
- $i$  Rapporto di riduzione / Ratio
- $P_1$  [kW] Potenza in entrata / Input power
- $M_2$  [Nm] Coppia nominale in uscita in funzione di  $P_1$  / Output torque referred to  $P_1$
- $sf$  Fattore di servizio / Service factor
- $R_2$  [N] Carico radiale ammissibile in uscita / Permitted output radial load
- $A_2$  [N] Carico assiale ammissibile in uscita / Permitted output axial load

**Carichi radiali**

**Radial loads**

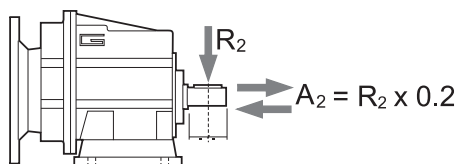

	CMG 002												
$n_2$ [min <sup>-1</sup> ]	700	600	500	400	250	180	150	120	100	80	60	40	10
$R_2$ [N]	416	437	465	501	586	653	748	806	958	1032	1136	1300	1300

Quando il carico radiale risultante non è applicato sulla mezzeria dell'albero occorre calcolare quello effettivo con la seguente formula:

When the resulting radial load is not applied on the centre line of the shaft it is necessary to calculate the effective load with the following formula:

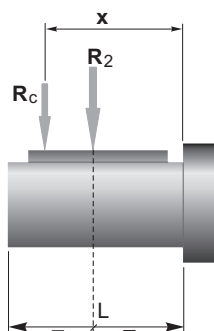

	CMG 002
$a$	73
$b$	53
$R_{2MAX}$	1300

$$R_c = \frac{R_2 \cdot a}{(b+x)} \leq R_{2MAX}$$

$a, b =$  valori riportati nella tabella  
 $a, b =$  values given in the table

$$R \leq R_c$$

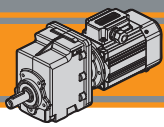

**CMG**

Motoriduttori CA ad ingranaggi cilindrici  
AC Helical in-line gearmotors



Motori applicabili

IEC Motor adapters

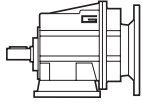
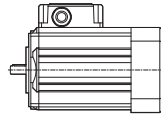





		SMT				SMM			
		5014	5624	6324	7124	5014	5624	6324	7124
		5024	5634	6334	7134	5024	5634	6334	7134
		5034	5644	6344	7144	5034	5644	6344	7144
		5044	5654						
<b>CMG</b>	<b>002</b>	5.03 - 55.10							

5.03 - 55.10 Rapporti di riduzione i / Ratio i

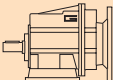
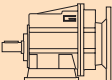
Dati tecnici

Technical data

P <sub>1</sub> [kW]	n <sub>2</sub> [min <sup>-1</sup> ]	M <sub>2</sub> [Nm]	sf	i		P <sub>1</sub> [kW]	n <sub>2</sub> [min <sup>-1</sup> ]	M <sub>2</sub> [Nm]	sf	i	
<b>0.04</b>						<b>0.09</b>					
SMT5014	<b>279</b>	1	30.4	5.03	<b>CMG002</b>	SMT5034	<b>279</b>	3	13.5	5.03	<b>CMG002</b>
SMM5014	<b>230</b>	2	25.0	6.10		SMM5034	<b>230</b>	4	11.1	6.10	
(1400 min <sup>-1</sup> )	<b>187</b>	2	20.4	7.49		SMT5624	<b>187</b>	4	9.1	7.49	
	<b>156</b>	2	21.2	8.99		SMM5624	<b>156</b>	5	9.4	8.99	
	<b>138</b>	3	18.8	10.16		(1400 min <sup>-1</sup> )	<b>138</b>	6	8.3	10.16	
	<b>116</b>	3	15.8	12.07			<b>116</b>	7	7.0	12.07	
	<b>105</b>	4	20.0	13.40			<b>105</b>	8	8.9	13.40	
	<b>92</b>	4	17.7	15.14			<b>92</b>	9	7.8	15.14	
	<b>77</b>	5	14.7	18.17			<b>77</b>	11	6.5	18.17	
	<b>65</b>	6	12.4	21.58			<b>65</b>	13	5.5	21.58	
	<b>60</b>	6	11.4	23.51			<b>60</b>	14	5.1	23.51	
	<b>56</b>	7	10.6	25.10			<b>56</b>	15	4.7	25.10	
	<b>52</b>	7	9.9	27.08			<b>52</b>	16	4.4	27.08	
	<b>43</b>	9	8.2	32.49			<b>43</b>	19	3.7	32.49	
	<b>33</b>	11	6.4	42.04		<b>33</b>	25	2.8	42.04		
	<b>31</b>	12	6.0	44.89		<b>31</b>	26	2.6	44.89		
	<b>29</b>	13	5.5	48.86		<b>29</b>	29	2.4	48.86		
	<b>25</b>	14	4.8	55.10		<b>25</b>	32	2.2	55.10		
<b>0.06</b>						<b>0.12</b>					
SMT5024	<b>279</b>	2	20.3	5.03	<b>CMG002</b>	SMT5044	<b>279</b>	4	10.1	5.03	<b>CMG002</b>
SMM5024	<b>230</b>	2	16.7	6.10		SMT5634	<b>230</b>	5	8.3	6.10	
(1400 min <sup>-1</sup> )	<b>187</b>	3	13.6	7.49		SMM5634	<b>187</b>	6	6.8	7.49	
	<b>156</b>	4	14.2	8.99		(1400 min <sup>-1</sup> )	<b>156</b>	7	7.1	8.99	
	<b>138</b>	4	12.5	10.16			<b>138</b>	8	6.3	10.16	
	<b>116</b>	5	10.5	12.07			<b>116</b>	9	5.3	12.07	
	<b>105</b>	5	13.3	13.40			<b>105</b>	11	6.7	13.40	
	<b>92</b>	6	11.8	15.14			<b>92</b>	12	5.9	15.14	
	<b>77</b>	7	9.8	18.17			<b>77</b>	14	4.9	18.17	
	<b>65</b>	8	8.3	21.58			<b>65</b>	17	4.1	21.58	
	<b>60</b>	9	7.6	23.51			<b>60</b>	18	3.8	23.51	
	<b>56</b>	10	7.1	25.10			<b>56</b>	20	3.5	25.10	
	<b>52</b>	11	6.6	27.08			<b>52</b>	21	3.3	27.08	
	<b>43</b>	13	5.5	32.49			<b>43</b>	26	2.7	32.49	
	<b>33</b>	17	4.2	42.04		<b>33</b>	33	2.1	42.04		
	<b>31</b>	18	4.0	44.89		<b>31</b>	35	2.0	44.89		
	<b>29</b>	19	3.6	48.86		<b>29</b>	38	1.8	48.86		
	<b>25</b>	22	3.2	55.10		<b>25</b>	43	1.6	55.10		



Motori Motors	SMT		SMM	
		5014 5024 5034 5044	5624 5634	5014 5024 5034
<b>IEC</b>	<b>56 B14</b>		<b>56 B14</b>	

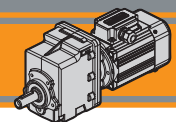

Dati tecnici

Technical data

P <sub>1</sub> [kW]	n <sub>2</sub> [min <sup>-1</sup> ]	M <sub>2</sub> [Nm]	sf	i	
------------------------	--	------------------------	----	---	--

P <sub>1</sub> [kW]	n <sub>2</sub> [min <sup>-1</sup> ]	M <sub>2</sub> [Nm]	sf	i	
------------------------	--	------------------------	----	---	--

**0.18**

SMT5644	<b>279</b>	6	6.8	5.03	<b>CMG002</b>
SMM5644	<b>230</b>	7	5.6	6.10	
SMT6324	<b>187</b>	9	4.5	7.49	
SMM6324	<b>156</b>	11	4.7	8.99	
(1400 min <sup>-1</sup> )	<b>138</b>	12	4.2	10.16	
	<b>116</b>	14	3.5	12.07	
	<b>105</b>	16	4.4	13.40	
	<b>92</b>	18	3.9	15.14	
	<b>77</b>	21	3.3	18.17	
	<b>65</b>	25	2.8	21.58	
	<b>60</b>	28	2.5	23.51	
	<b>56</b>	30	2.4	25.10	
	<b>52</b>	32	2.2	27.08	
	<b>43</b>	38	1.8	32.49	
	<b>33</b>	50	1.4	42.04	
	<b>31</b>	53	1.3	44.89	
	<b>29</b>	58	1.2	48.86	
	<b>25</b>	65	1.1	55.10	

**0.37**

SMT6344	<b>279</b>	12	3.3	5.03	<b>CMG002</b>
SMT7124	<b>230</b>	15	2.7	6.10	
SMM7124	<b>187</b>	18	2.2	7.49	
(1400 min <sup>-1</sup> )	<b>156</b>	22	2.3	8.99	
	<b>138</b>	25	2.0	10.16	
	<b>116</b>	29	1.7	12.07	
	<b>105</b>	32	2.2	13.40	
	<b>92</b>	37	1.9	15.14	
	<b>77</b>	44	1.6	18.17	
	<b>65</b>	52	1.3	21.58	
	<b>60</b>	57	1.2	23.51	
	<b>56</b>	61	1.2	25.10	
	<b>52</b>	66	1.1	27.08	
	<b>43</b>	79	0.9	32.49	

**0.25**

SMT5654	<b>279</b>	8	4.9	5.03	<b>CMG002</b>
SMT6334	<b>230</b>	10	4.0	6.10	
SMM6334	<b>187</b>	12	3.3	7.49	
(1400 min <sup>-1</sup> )	<b>156</b>	15	3.4	8.99	
	<b>138</b>	17	3.0	10.16	
	<b>116</b>	20	2.5	12.07	
	<b>105</b>	22	3.2	13.40	
	<b>92</b>	25	2.8	15.14	
	<b>77</b>	30	2.4	18.17	
	<b>65</b>	35	2.0	21.58	
	<b>60</b>	38	1.8	23.51	
	<b>56</b>	41	1.7	25.10	
	<b>52</b>	44	1.6	27.08	
	<b>43</b>	53	1.3	32.49	
	<b>33</b>	69	1.0	42.04	
	<b>31</b>	73	1.0	44.89	
	<b>29</b>	80	0.9	48.86	
	<b>25</b>	90	0.8	55.10	

**0.55**

SMT7134	<b>279</b>	18	2.2	5.03	<b>CMG002</b>
SMM7134	<b>230</b>	22	1.8	6.10	
(1400 min <sup>-1</sup> )	<b>187</b>	27	1.5	7.49	
	<b>156</b>	32	1.5	8.99	
	<b>138</b>	37	1.4	10.16	
	<b>116</b>	43	1.2	12.07	
	<b>105</b>	48	1.5	13.40	
	<b>92</b>	55	1.3	15.14	
	<b>77</b>	65	1.1	18.17	
	<b>65</b>	78	0.9	21.58	

**0.75**

SMT7144	<b>279</b>	25	1.6	5.03	<b>CMG002</b>
(1400 min <sup>-1</sup> )	<b>230</b>	30	1.3	6.10	
	<b>187</b>	37	1.1	7.49	
	<b>156</b>	44	1.1	8.99	
	<b>138</b>	50	1.0	10.16	
	<b>116</b>	59	0.8	12.07	
	<b>105</b>	66	1.1	13.40	
	<b>92</b>	74	0.9	15.14	



Motori Motors	SMT			SMM		
		5644 5654	6324 6334 6344	7124 7134 7144	5644	6324 6334
<b>IEC</b>	<b>56 B14</b>	<b>63 B14</b>	<b>71 B14</b>	<b>56 B14</b>	<b>63 B14</b>	<b>71 B14</b>

Dati tecnici elettrici

Electrical technical data



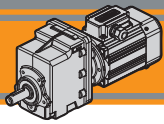

**CMG**

Motoriduttori CA ad ingranaggi cilindrici  
AC Helical in-line gearmotors

**MINI**  
TECNO

Dimensioni

Dimensions

**CMG 002 U**

**CMG 002 U**

SMT50...TEFC  
SMM50... TEFC

SMT50...TENV  
SMM50... TENV

S3 servizio 30%  
duty

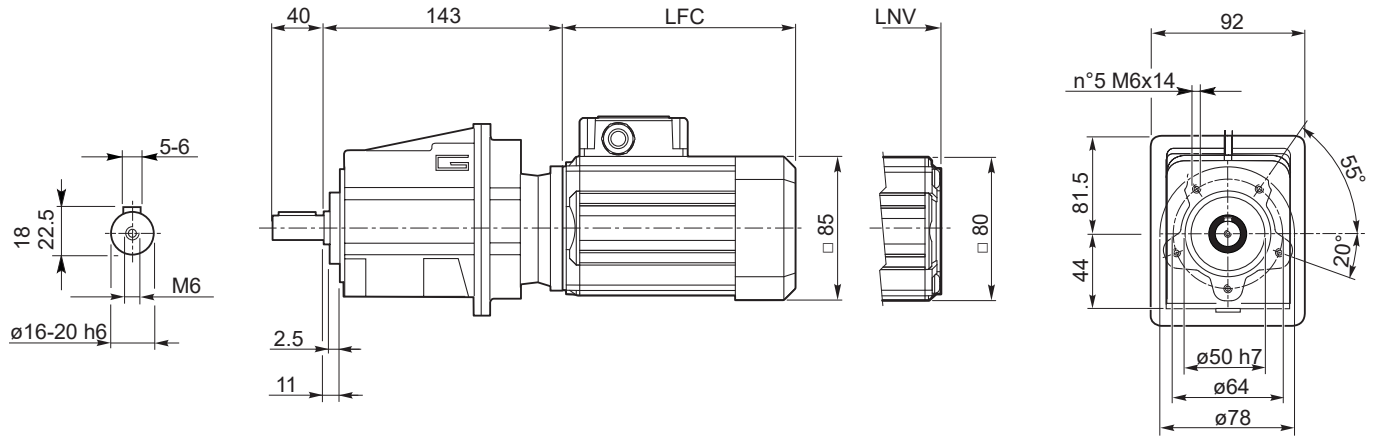

SMT	LFC	LNV	Kg	
5014	135.5	108.5	5.2	
5024	150.5	123.5	5.6	
5034	175.5	148.5	6.4	
5044	200.5	173.5	7.1	

SMM	LFC	LNV	Kg	
5014	150.5	123.5	5.6	
5024	175.5	148.5	6.4	
5034	200.5	173.5	7.1	

Nota: il condensatore sarà fornito a corredo  
Note: the capacitor will be supplied separately

- CMG...H → AE8
- CMG...F → AE8
- CMG...H/F → AE9

**CMG 002 U**

SMT56...TEFC  
SMM56... TEFC

SMT56...TENV  
SMM56... TENV

S3 servizio 30%  
duty

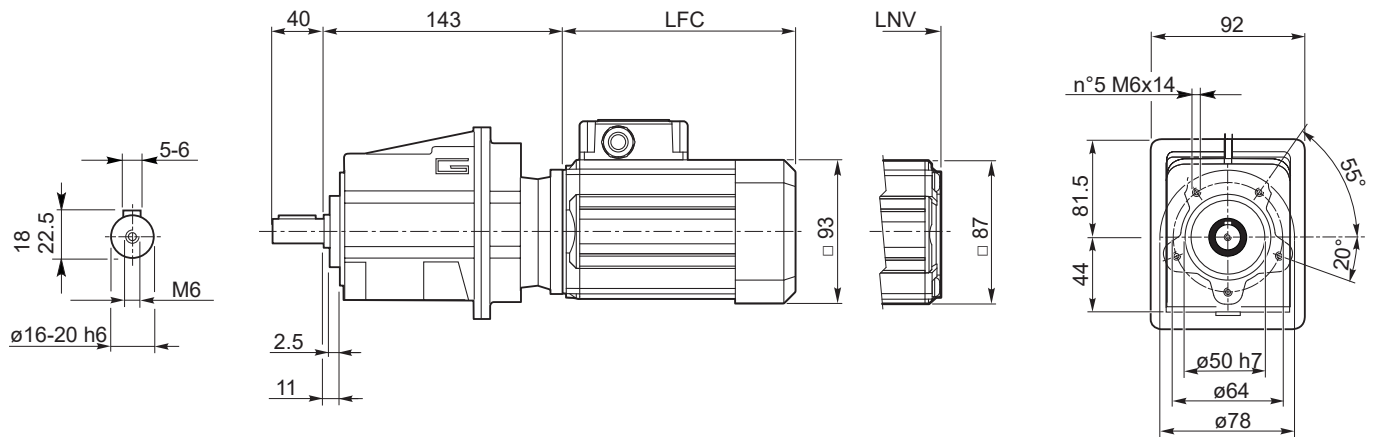

SMT	LFC	LNV	Kg	
5624	141	117	5.7	
5634	151	127	6.1	
5644	186	162	7.3	
5654	206	182	8	

SMM	LFC	LNV	Kg	
5624	151	127	6	
5634	171	147	6.6	
5644	206	182	7.9	

Nota: il condensatore sarà fornito a corredo  
Note: the capacitor will be supplied separately

- CMG...H → AE8
- CMG...F → AE8
- CMG...H/F → AE9

SMT SMM  
OPTIONS → AB1 AC1 AD1

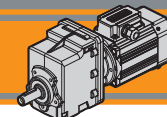

Dimensioni

Dimensions

CMG 002 U

CMG 002 U

SMT63...TEFC  
SMM63... TEFC

SMT63...TENV  
SMM63... TENV

S3 servizio duty 30%

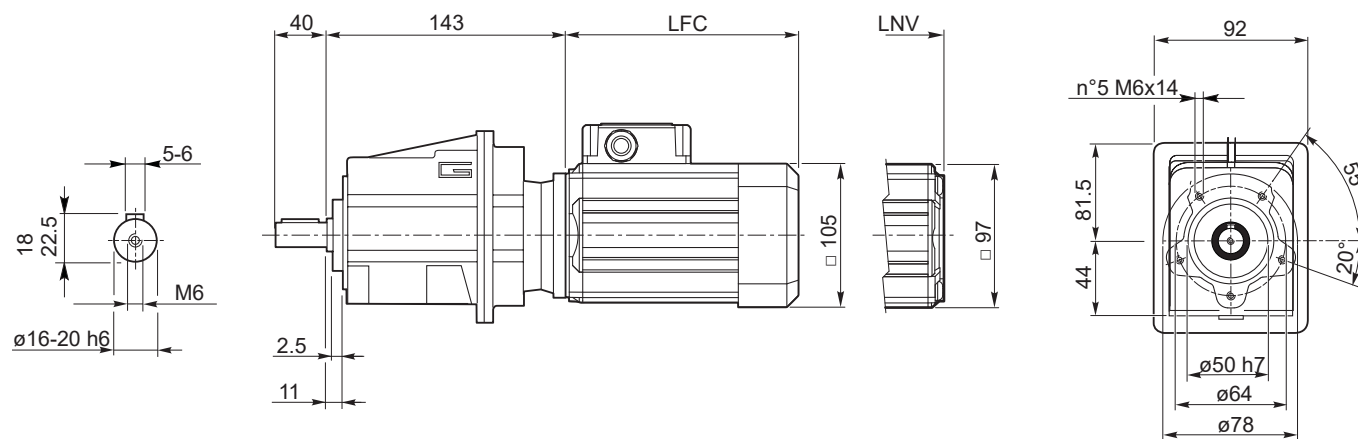

SMT	LFC	LNV	Kg	
6324	165.5	138.5	7.2	
6334	180.5	153.5	7.9	
6344	205.5	178.5	9.1	

SMM	LFC	LNV	Kg	
6324	180.5	153.5	8	
6334	205.5	178.5	9.2	

Nota: il condensatore sarà fornito a corredo  
Note: the capacitor will be supplied separately

CMG...H → AE8

CMG...F → AE8

CMG...H/F → AE9

SMT SMM  
OPTIONS → AB1 AC1 AD1

CMG 002 U

SMT71...TEFC  
SMM71... TEFC

SMT71...TENV  
SMM71... TENV

S3 servizio duty 30%

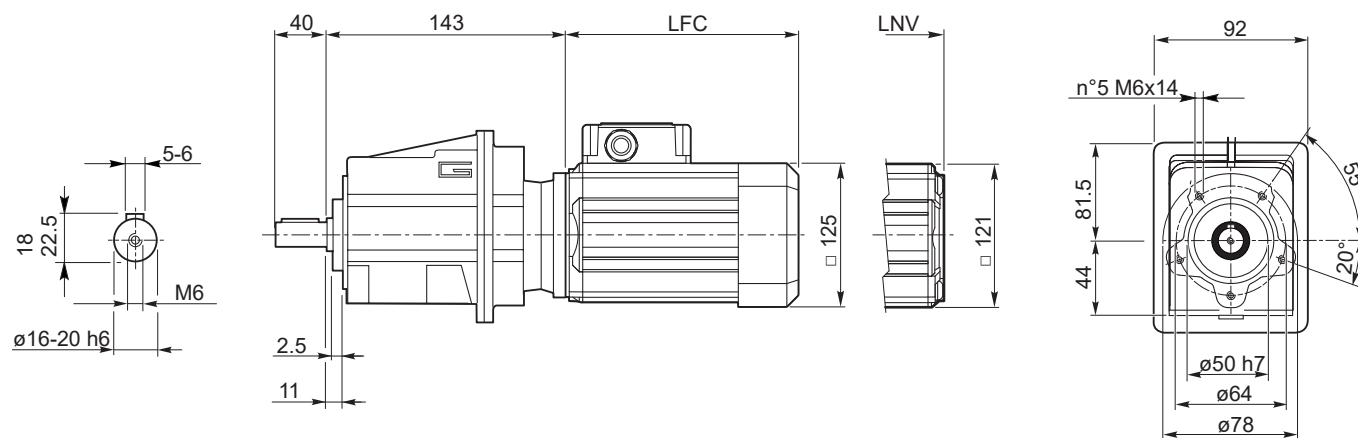

SMT	LFC	LNV	Kg	
7124	174	174	9.4	
7134	189	189	10.5	
7144	214	214	12.2	

SMM	LFC	LNV	Kg	
7124	189	160.5	10.1	
7134	214	185.5	12.1	

Nota: il condensatore sarà fornito a corredo  
Note: the capacitor will be supplied separately

CMG...H → AE8

CMG...F → AE8

CMG...H/F → AE9

SMT SMM  
OPTIONS → AB1 AC1 AD1

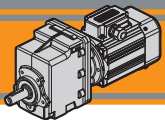

**CMG**

Motoriduttori CA ad ingranaggi cilindrici  
AC Helical in-line gearmotors

**MINI**  
TECNO

Dimensioni

Dimensions

**CMG..H**

**CMG002 H..**

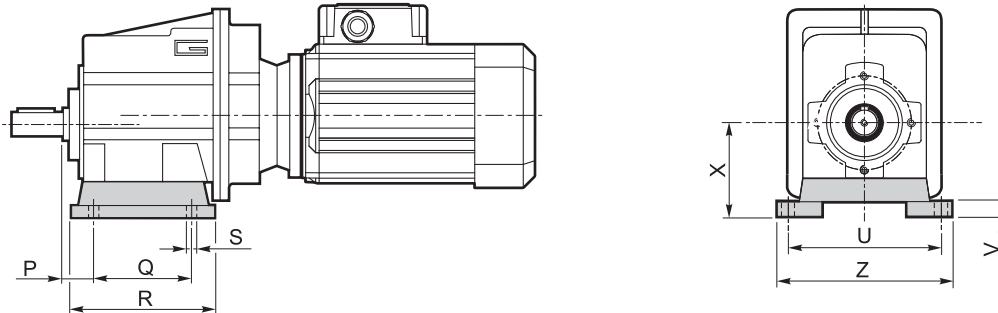

Versione H / H Version										
CMG	P	Q	R	S	U	V	X	Z	Piede / Foot	
									Tipo / Type	Peso / Weight [kg]
002	18	60	80	9	100	10	60	120	H60	0.2
	18	80	104	9	110 - 120	10	75	145	H75	0.3
	18	50 - 87	110	9	110	10	85	135	H85	0.4

■ Preferenziale / Preferred

**CMG..F**

**CMG002 F..**

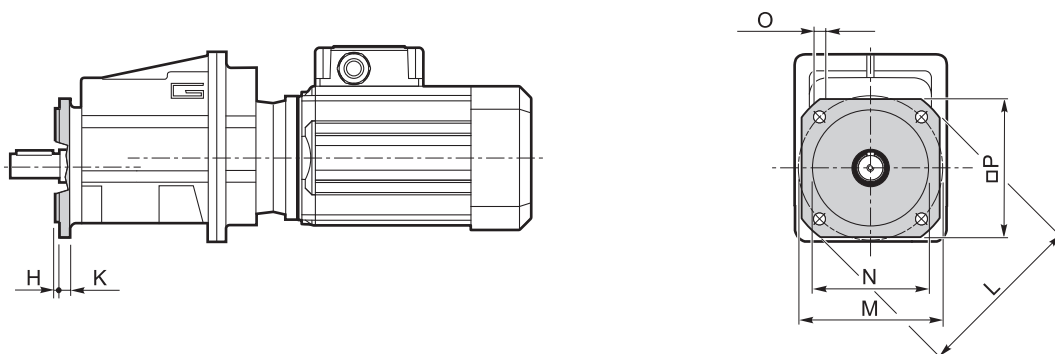

Versione F / F Version										
CMG	H	K	L	M	N f7	O	P	Flangia / Flange		
								Tipo / Type	Peso / Weight [kg]	
002	3.5	7	105	85	70	6.5	90	F105	0.1	
	3.5	8	120	100	80	9	100	F120	0.2	
	3.5	8	140	115	95	9	115	F140	0.2	

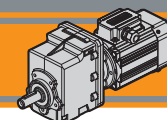

Dimensioni

Dimensions

CMG..H../F..

CMG002 H../F..

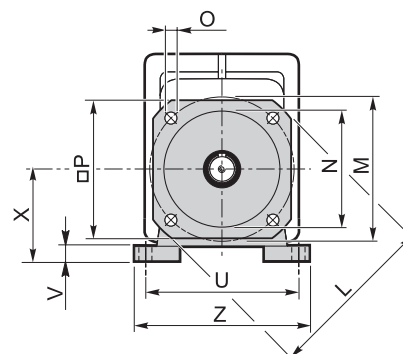
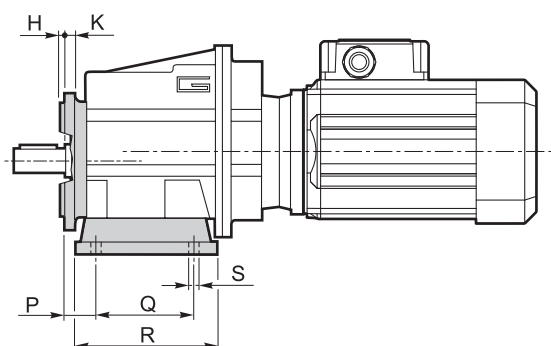

Versione H / H Version										Combinazioni possibili H/F Possible combinations H/F							
CMG	P	Q	R	S	U	V	X	Z	Piede / Foot		F105	F120	F140	F160	F200	F250	F300
									Tipo / Type	Peso / Weight [kg]							
002	18	60	80	9	100	10	60	120	H60	0.2	•	•	•				
	18	80	104	9	110 - 120	10	75	145	H75	0.3	•	•	•				
	18	50 - 87	110	9	110	10	85	135	H85	0.4	•	•	•				

■ Preferenziale / Preferred

• Combinazioni possibili H/F / Possible combinations H/F

Versione F / F Version									
CMG	H	K	L	M	N f7	O	P	Flangia / Flange	
								Tipo / Type	Peso / Weight [kg]
002	3.5	7	105	85	70	6.5	90	F105	0.1
	3.5	8	120	100	80	7	100	F120	0.2
	3.5	8	140	115	95	9	115	F140	0.2



**MINI**  **TECNO**™  
**small** but strong

**CMB**

AC

Motoriduttori CA ad assi ortogonali  
AC Helical bevel gearmotors

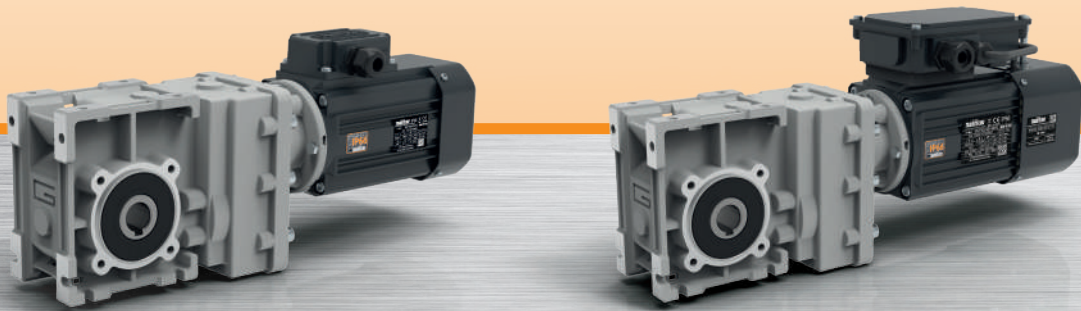

**MINI**  **TECNO**™ brand of  
**TRANSTECNO**®





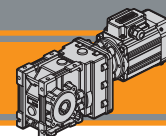

		Pag. Page
<b>Indice</b>	<b>Index</b>	
Caratteristiche tecniche	<i>Technical features</i>	<b>AC2</b>
Designazione	<i>Classification</i>	<b>AC2</b>
Sensi di rotazione	<i>Direction of rotation</i>	<b>AC3</b>
Simbologia	<i>Symbols</i>	<b>AC3</b>
Lubrificazione	<i>Lubrication</i>	<b>AC3</b>
Carichi radiali	<i>Radial loads</i>	<b>AC3</b>
Motori applicabili	<i>Motor adapters</i>	<b>AC4</b>
Dati tecnici	<i>Technical data</i>	<b>AC4</b>
Dimensioni	<i>Dimensions</i>	<b>AC7</b>
Accessori	<i>Accessories</i>	<b>AC8</b>

Questa sezione annulla e sostituisce ogni precedente edizione o revisione. Qualora questa sezione non Vi sia giunta in distribuzione controllata, l'aggiornamento dei dati ivi contenuto non è assicurato. **In tal caso la versione più aggiornata è disponibile sul nostro sito internet [www.transtecno.com](http://www.transtecno.com)**

*This section replaces any previous edition and revision. If you obtained this catalogue other than through controlled distribution channels, the most up to date content is not guaranteed. In this case the latest version is available on our web site [www.transtecno.com](http://www.transtecno.com)*

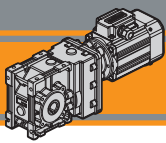

**CMB**

Motoriduttori CA ad assi ortogonali  
AC Helical bevel gearmotors



**Caratteristiche tecniche**

**Technical features**

Le caratteristiche principali dei motoriduttori CMB sono:

CMB gearmotor range has the following main features:

- Costruzione compatta
- Motorizzazioni in corrente alternata monofase e trifase
- Carcassa motore estrusa in alluminio anodizzato nero
- Carcasse dei riduttori in pressofusione di alluminio
- Motore elettrico AC con grado di protezione IP66
- Lubrificazione permanente con olio sintetico
- Ingranaggi cilindrici a denti elicoidali, induriti e rettificati
- Disponibili sia nella versione ventilata TEFC (servizio S1) che non ventilata TENV (servizio S3)
- Protezione termica PTO 150°C per le taglie motore 56, 63 e 71.
- SMT56, SMT63 e SMT71 adatti al funzionamento con alimentazione da inverter
- Disponibili nelle versioni autofrenante, servoventilata e con certificazione UL.
- Disponibili con giunto elastico in entrata

- Compact design
- AC single phase and three phase motors available
- Motor extruded aluminum housing black anodized
- Gearbox die-cast aluminum housing
- AC electric motor in IP66 protection Standard
- Permanent synthetic oil long-life lubrication
- Ground-hardened helical gears
- Fan cooled TEFC (duty S1) and not ventilated TENV (duty S3) versions available
- PTO 150°C thermal protection for motor sizes 56, 63 and 71.
- SMT56, SMT63 and SMT71 are suitable for inverter duty
- Brake motors, forced ventilation motors and UL compliance versions available.
- Available with input flexible couplin

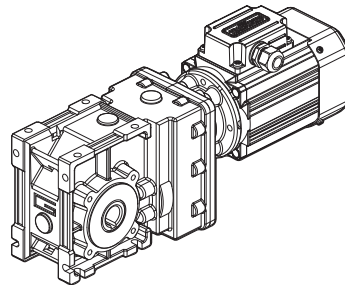

**Designazione**

**Classification**

RIDUTTORE / GEARBOX											
CMB	40 2		U	9.81	D20	63	B14	SZDX	BRSX	90	FX
Tipo Type	Grandezza Size	Stadi Stages	Versione Version	Rapporto Ratio	Albero cavo uscita Hollow output shaft	IEC	Forma costruttiva Version	Albero di uscita Output shaft	Braccio di reazione Torque arm	Angolo Angle	Giunto elastico Flexible coupling
	40	2	U FD FS FBD FBS FLD FLS	vedi tabelle see tables	vedi tabelle see tables	 56.. 63.. 71..	B14	SZDX SZSX DZ	BRDX BRSX *	0° 90° 180° 270°	FX  17
Versione Riduttore Gearbox Version			Albero di uscita Output shaft			Braccio di reazione Torque arm *		Angolo Angle			
 U    FD    FS FLD    FBD    FBS			 SZDX    SZSX    DZ			 BRDX    BRSX		 90°    90° 180°    270°    0°    270°			

\* NOTA: il braccio di reazione viene fornito smontato.  
NOTE: the torque arm will be supplied not assembled.

MOTORE TRIFASE / THREE PHASE MOTOR										
SMT	63	2	4	0.18 kW	B14	230-400 V	50 Hz	TEFC	BR	T1
Tipo Type	Grandezza Size	Indicativo potenza Power coefficient	Poli Poles	Potenza Power	Forma costruttiva Version	Tensione Voltage	Frequenza Frequency	Ventilazione Fan cooling	Opzioni Options	Pos. Morsetteria Terminal box pos.
SMT	Vedere tab. See tab.	1-2-3-4-5	4	0.04 kW ... 0.75 kW	B14	230-400 V  460V	50Hz  60Hz	TEFC  TENV	 AB1 AC1 AD1	T1 (Std)  T4    T2 T3

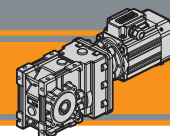

MOTORE MONOFASE / SINGLE PHASE MOTOR										
SMM	63	2	4	0.18 kW	B14	230 V	50 Hz	TEFC	UL-CSA	T1
Tipo Type	Grandezza Size	Indicativo potenza Power coefficient	Poli Poles	Potenza Power	Forma costruttiva Version	Tensione Voltage	Frequenza Frequency	Ventilazione Fan cooling	Opzioni Options	Pos. Morsetteria Terminal box pos.
<b>SMM</b>	Vedere tab. See tab.	<b>1-2-3-4</b>	<b>4</b>	<b>0.04 kW</b> ... <b>0.55 kW</b>	<b>B14</b>	<b>230V</b>	<b>50Hz</b>	<b>TEFC</b>  <b>TENV</b>	<b>AD1</b>	T1 (Std) T4 T2 T3

**Sensi di rotazione**

**Direction of rotation**

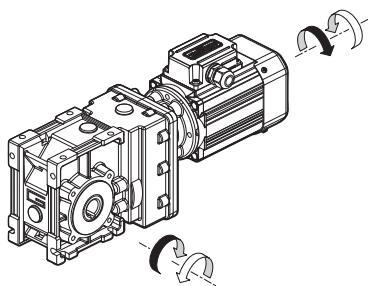

**Simbologia**

**Symbols**

$n_1$ [min <sup>-1</sup> ]	Velocità in ingresso / <i>Input speed</i>	$M_2$ [Nm]	Coppia in uscita in funzione di $P_1$ / <i>Output torque referred to <math>P_1</math></i>
$n_2$ [min <sup>-1</sup> ]	Velocità in uscita / <i>Output speed</i>	sf	Fattore di servizio / <i>Service factor</i>
i	Rapporto di riduzione / <i>Ratio</i>	$A_2$ [N]	Carico assiale ammissibile in uscita / <i>Permitted output axial load</i>
$P_1$ [kW]	Potenza in entrata / <i>Input power</i>	$R_2$ [N]	Carico radiale ammissibile in uscita / <i>Permitted output radial load</i>

**Lubrificazione**

**Lubrication**

Tutti i riduttori nelle taglie 402 sono forniti completi di lubrificante sintetico viscosità 320, pertanto possono essere installati in qualunque posizione di montaggio e non necessitano di manutenzione.

*Permanent synthetic oil long-life lubrication (viscosity grade 320) makes it possible to use sizes 402 in all mounting positions; for this reason they can be installed in any assembly position and do not require maintenance.*

**Carichi radiali**

**Radial loads**

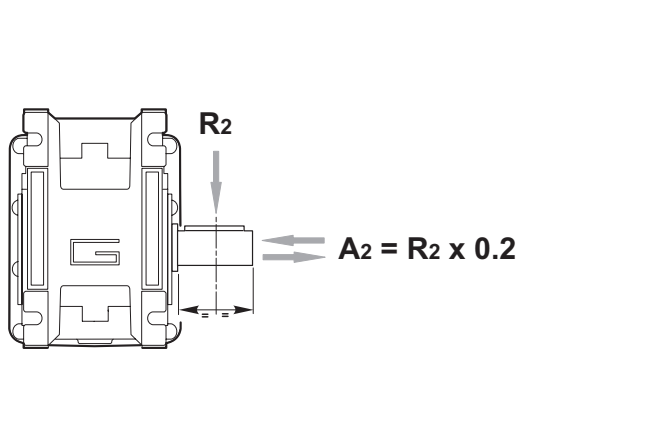

$n_2$ [min <sup>-1</sup> ]	$R_2$ [N]
	<b>CMB 402</b>
400	905
300	996
200	1141
170	1204
140	1414
100	1582
90	1638
60	2047
40	2524
30	2778
20	3180
15	3500
10	3500

Quando il carico radiale risultante non è applicato sulla mezza-ria dell'albero occorre calcolare quello effettivo con la seguente formula:

*When the resulting radial load is not applied on the centre line of the shaft it is necessary to calculate the effective load with the following formula:*

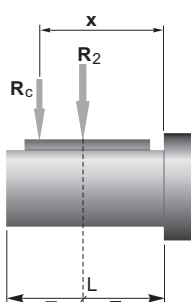

	<b>CMB 402</b>
a	86
b	66
$R_{2MAX}$	3500

$$R_c = \frac{R_2 \cdot a}{(b + x)} \leq R_{2MAX}$$

$$R \leq R_c$$

*a, b = valori riportati nella tabella  
a, b = values given in the table*

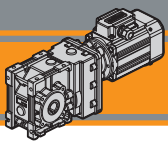

**CMB**

Motoriduttori CA ad assi ortogonali  
AC Helical bevel gearmotors



Motori applicabili

Motor adapters

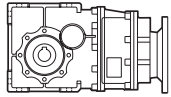
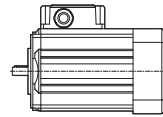





		SMT				SMM			
		5014 5024 5034 5044	5624 5634 5644 5654	6324 6334 6344	7124 7134 7144	5014 5024 5034	5624 5634 5644	6324 6334	7124 7134
<b>CMB</b>	<b>402</b>	6.18 - 72.50							

6.18 - 72.50

Rapporti di riduzione i  
Ratio i

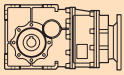
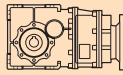
Dati tecnici

Technical data

P <sub>1</sub> [kW]	n <sub>2</sub> [min <sup>-1</sup> ]	M <sub>2</sub> [Nm]	sf	i		P <sub>1</sub> [kW]	n <sub>2</sub> [min <sup>-1</sup> ]	M <sub>2</sub> [Nm]	sf	i	
<b>0.04</b>						<b>0.06</b>					
SMT5014	<b>227</b>	2	25.3	6.18	<b>CMB402</b>	SMT5024	<b>42</b>	13	5.0	33.57	<b>CMB402</b>
SMM5014	<b>187</b>	2	20.8	7.49		SMM5024	<b>39</b>	14	4.7	35.63	
(1400 min <sup>-1</sup> )	<b>152</b>	2	16.9	9.20		(1400 min <sup>-1</sup> )	<b>33</b>	16	4.0	42.75	
	<b>118</b>	3	14.8	11.83			<b>25</b>	21	3.1	55.31	
	<b>112</b>	3	14.1	12.48			<b>24</b>	23	2.9	59.06	
	<b>94</b>	4	11.8	14.83			<b>22</b>	25	2.6	64.29	
	<b>79</b>	5	10.0	17.63			<b>19</b>	28	2.3	72.50	
	<b>75</b>	5	11.5	18.60							
	<b>63</b>	6	9.6	22.33							
	<b>59</b>	6	9.0	23.91							
	<b>48</b>	7	8.8	28.89							
	<b>45</b>	8	8.2	30.84							
	<b>42</b>	9	7.5	33.57							
	<b>39</b>	9	7.1	35.63							
	<b>33</b>	11	5.9	42.75							
	<b>25</b>	14	4.6	55.31							
	<b>24</b>	15	4.3	59.06							
	<b>22</b>	16	3.9	64.29							
	<b>19</b>	19	3.5	72.50							
<b>0.06</b>						<b>0.09</b>					
SMT5024	<b>227</b>	2	16.8	6.18	<b>CMB402</b>	SMT5034	<b>227</b>	4	11.2	6.18	<b>CMB402</b>
SMM5024	<b>187</b>	3	13.9	7.49		SMM5034	<b>187</b>	4	9.3	7.49	
(1400 min <sup>-1</sup> )	<b>152</b>	4	11.3	9.20		(1400 min <sup>-1</sup> )	<b>152</b>	5	7.5	9.20	
	<b>118</b>	5	9.9	11.83			<b>118</b>	7	6.6	11.83	
	<b>112</b>	5	9.4	12.48			<b>112</b>	7	6.2	12.48	
	<b>94</b>	6	7.9	14.83			<b>94</b>	9	5.3	14.83	
	<b>79</b>	7	6.6	17.63			<b>79</b>	10	4.4	17.63	
	<b>75</b>	7	7.7	18.60			<b>75</b>	11	5.1	18.60	
	<b>63</b>	9	6.4	22.33			<b>63</b>	13	4.3	22.33	
	<b>59</b>	9	6.0	23.91			<b>59</b>	14	4.0	23.91	
	<b>48</b>	11	5.8	28.89			<b>48</b>	17	3.9	28.89	
	<b>45</b>	12	5.5	30.84			<b>45</b>	18	3.7	30.84	
							<b>42</b>	19	3.4	33.57	
							<b>39</b>	21	3.2	35.63	
							<b>33</b>	25	2.6	42.75	
							<b>25</b>	32	2.0	55.31	
						<b>24</b>	34	1.9	59.06		
						<b>22</b>	37	1.8	64.29		
						<b>19</b>	42	1.6	72.50		



Motori Motors	SMT		SMM	
		5014 5024 5034	5624	5014 5024 5034
<b>IEC</b>	<b>56 B14</b>		<b>56 B14</b>	

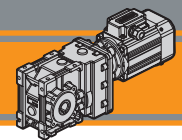

Dati tecnici

Technical data

P <sub>1</sub> [kW]	n <sub>2</sub> [min <sup>-1</sup> ]	M <sub>2</sub> [Nm]	sf	i	
<b>0.12</b>					
SMT5044	<b>227</b>	5	8.4	6.18	<b>CMB402</b>
SMT5634	<b>187</b>	6	6.9	7.49	
SMM5634	<b>152</b>	7	5.6	9.20	
(1400 min <sup>-1</sup> )	<b>118</b>	9	4.9	11.83	
	<b>112</b>	10	4.7	12.48	
	<b>94</b>	11	3.9	14.83	
	<b>79</b>	14	3.3	17.63	
	<b>75</b>	14	3.8	18.60	
	<b>63</b>	17	3.2	22.33	
	<b>59</b>	18	3.0	23.91	
	<b>48</b>	22	2.9	28.89	
	<b>45</b>	24	2.7	30.84	
	<b>42</b>	26	2.5	33.57	
	<b>39</b>	27	2.4	35.63	
	<b>33</b>	33	2.0	42.75	
	<b>25</b>	43	1.5	55.31	
	<b>24</b>	45	1.4	59.06	
	<b>22</b>	49	1.3	64.29	
	<b>19</b>	56	1.2	72.50	

P <sub>1</sub> [kW]	n <sub>2</sub> [min <sup>-1</sup> ]	M <sub>2</sub> [Nm]	sf	i	
<b>0.18</b>					
SMT5644	<b>227</b>	7	5.6	6.18	<b>CMB402</b>
SMM5644	<b>187</b>	9	4.6	7.49	
SMT6324	<b>152</b>	11	3.8	9.20	
SMM6324	<b>118</b>	14	3.3	11.83	
(1400 min <sup>-1</sup> )	<b>112</b>	14	3.1	12.48	
	<b>94</b>	17	2.6	14.83	
	<b>79</b>	20	2.2	17.63	
	<b>75</b>	21	2.6	18.60	
	<b>63</b>	26	2.1	22.33	
	<b>59</b>	28	2.0	23.91	
	<b>48</b>	33	1.9	28.89	
	<b>45</b>	36	1.8	30.84	
	<b>42</b>	39	1.7	33.57	
	<b>39</b>	41	1.6	35.63	
	<b>33</b>	49	1.3	42.75	
	<b>25</b>	64	1.0	55.31	
	<b>24</b>	68	0.95	59.06	
	<b>22</b>	74	0.88	64.29	
	<b>19</b>	84	0.8	72.50	

P <sub>1</sub> [kW]	n <sub>2</sub> [min <sup>-1</sup> ]	M <sub>2</sub> [Nm]	sf	i	
<b>0.25</b>					
SMT5654	<b>227</b>	10	4.0	6.18	<b>CMB402</b>
SMT6334	<b>187</b>	12	3.3	7.49	
SMM6334	<b>152</b>	15	2.7	9.20	
(1400 min <sup>-1</sup> )	<b>118</b>	19	2.4	11.83	
	<b>112</b>	20	2.2	12.48	
	<b>94</b>	24	1.9	14.83	
	<b>79</b>	28	1.6	17.63	
	<b>75</b>	30	1.8	18.60	
	<b>63</b>	36	1.5	22.33	
	<b>59</b>	38	1.4	23.91	
	<b>48</b>	46	1.4	28.89	
	<b>45</b>	49	1.3	30.84	
	<b>42</b>	54	1.2	33.57	
	<b>39</b>	57	1.1	35.63	
	<b>33</b>	69	0.9	42.75	

P <sub>1</sub> [kW]	n <sub>2</sub> [min <sup>-1</sup> ]	M <sub>2</sub> [Nm]	sf	i	
<b>0.37</b>					
SMT6344	<b>227</b>	15	2.7	6.18	<b>CMB402</b>
SMT7124	<b>187</b>	18	2.3	7.49	
SMM7124	<b>152</b>	22	1.8	9.20	
(1400 min <sup>-1</sup> )	<b>118</b>	28	1.6	11.83	
	<b>112</b>	30	1.5	12.48	
	<b>94</b>	35	1.3	14.83	
	<b>79</b>	42	1.1	17.63	
	<b>75</b>	44	1.2	18.60	
	<b>63</b>	53	1.0	22.33	
	<b>59</b>	57	1.0	23.91	
	<b>48</b>	69	0.9	28.89	
	<b>45</b>	73	0.9	30.84	
	<b>42</b>	80	0.8	33.57	

P <sub>1</sub> [kW]	n <sub>2</sub> [min <sup>-1</sup> ]	M <sub>2</sub> [Nm]	sf	i	
<b>0.55</b>					
SMT7134	<b>227</b>	22	1.8	6.18	<b>CMB402</b>
SMM7134	<b>187</b>	26	1.5	7.49	
(1400 min <sup>-1</sup> )	<b>152</b>	32	1.2	9.20	
	<b>118</b>	42	1.1	11.83	
	<b>112</b>	44	1.0	12.48	
	<b>94</b>	52	0.9	14.83	

P <sub>1</sub> [kW]	n <sub>2</sub> [min <sup>-1</sup> ]	M <sub>2</sub> [Nm]	sf	i	
<b>0.75</b>					
SMT7144	<b>227</b>	30	1.3	6.18	<b>CMB402</b>
(1400 min <sup>-1</sup> )	<b>187</b>	36	1.1	7.49	
	<b>152</b>	44	0.9	9.20	



Motori Motors	SMT				SMM		
	5044	5634 5644 5654	6324 6334 6344	7124 7134 7144	5644	6324 6334	7124 7134
IEC	56 B14		63 B14	71 B14	56 B14	63 B14	71 B14

Dati tecnici elettrici

Electrical technical data



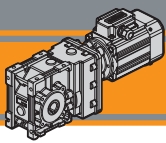

**CMB**

Motoriduttori CA ad assi ortogonali  
AC Helical bevel gearmotors

**MINI**  
TECNO

**Dimensioni**

**Dimensions**

**CMB 402 U**

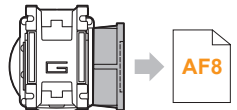
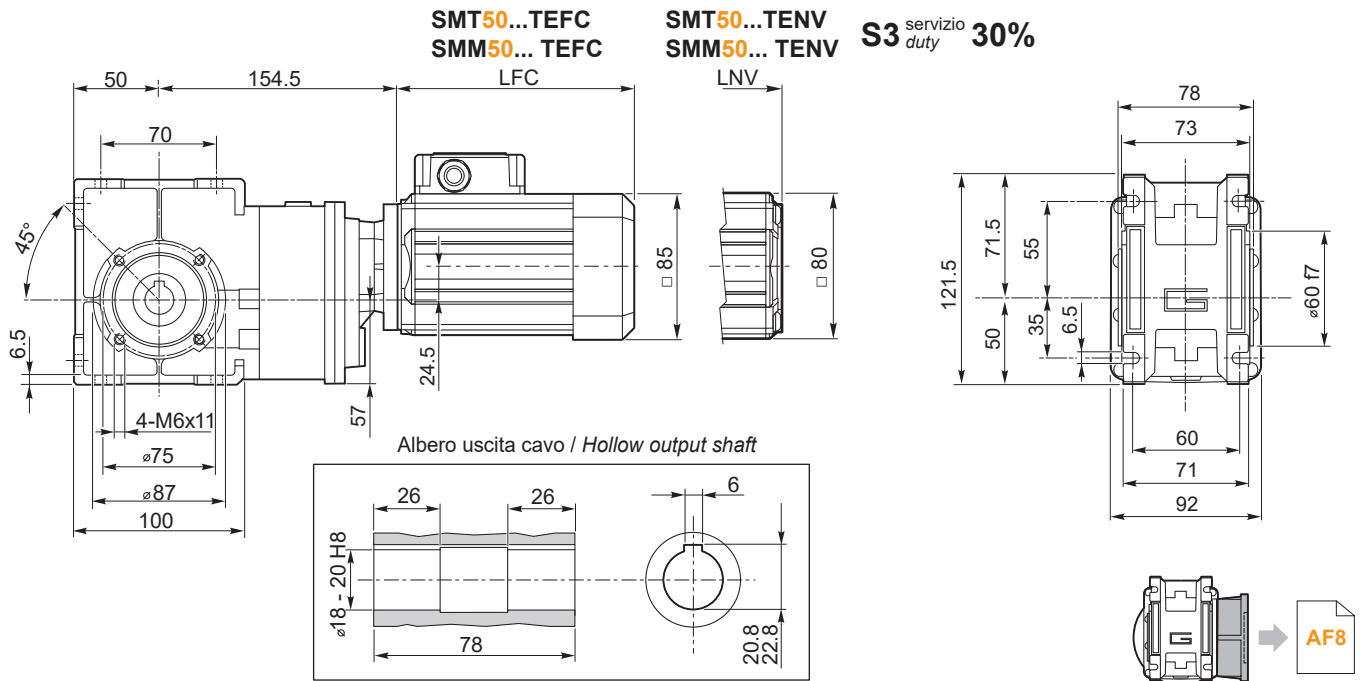

SMT	LFC	LNV	Kg	
5014	135.5	108.5	5.7	
5024	150.5	123.5	6.1	
5034	175.5	148.5	6.9	
5044	200.5	173.5	7.6	

SMM	LFC	LNV	Kg	
5014	150.5	123.5	6.1	
5024	175.5	148.5	6.9	
5034	200.5	173.5	7.6	

**Nota:**  
il condensatore sarà fornito a corredo

**Note:**  
the capacitor will be supplied separately

**CMB 402 U**

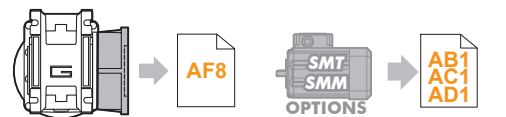
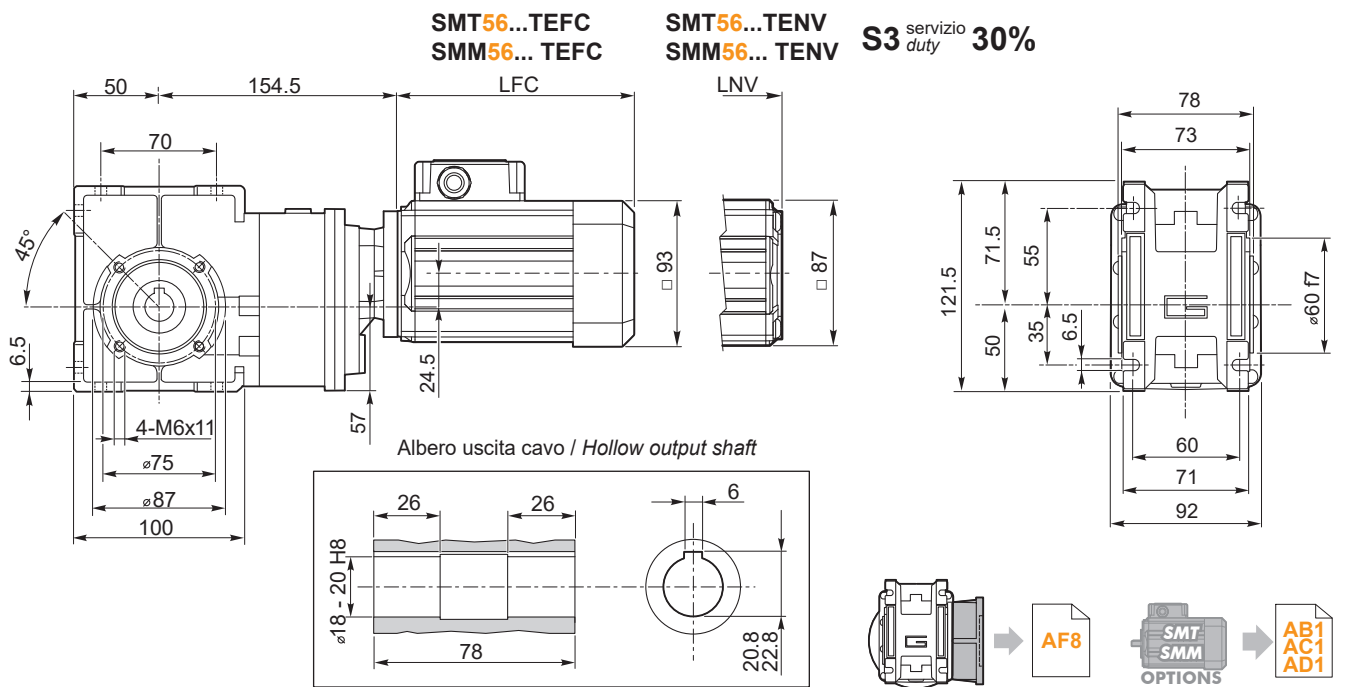

SMT	LFC	LNV	Kg	
5624	141	117	6.2	
5634	151	127	6.6	
5644	186	162	7.8	
5654	206	182	8.5	

SMM	LFC	LNV	Kg	
5624	151	127	6.5	
5634	171	147	7.1	
5644	206	182	8.4	

**Nota:**  
il condensatore sarà fornito a corredo

**Note:**  
the capacitor will be supplied separately

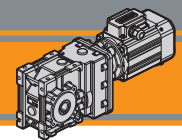

Dimensioni

Dimensions

CMB 402 U

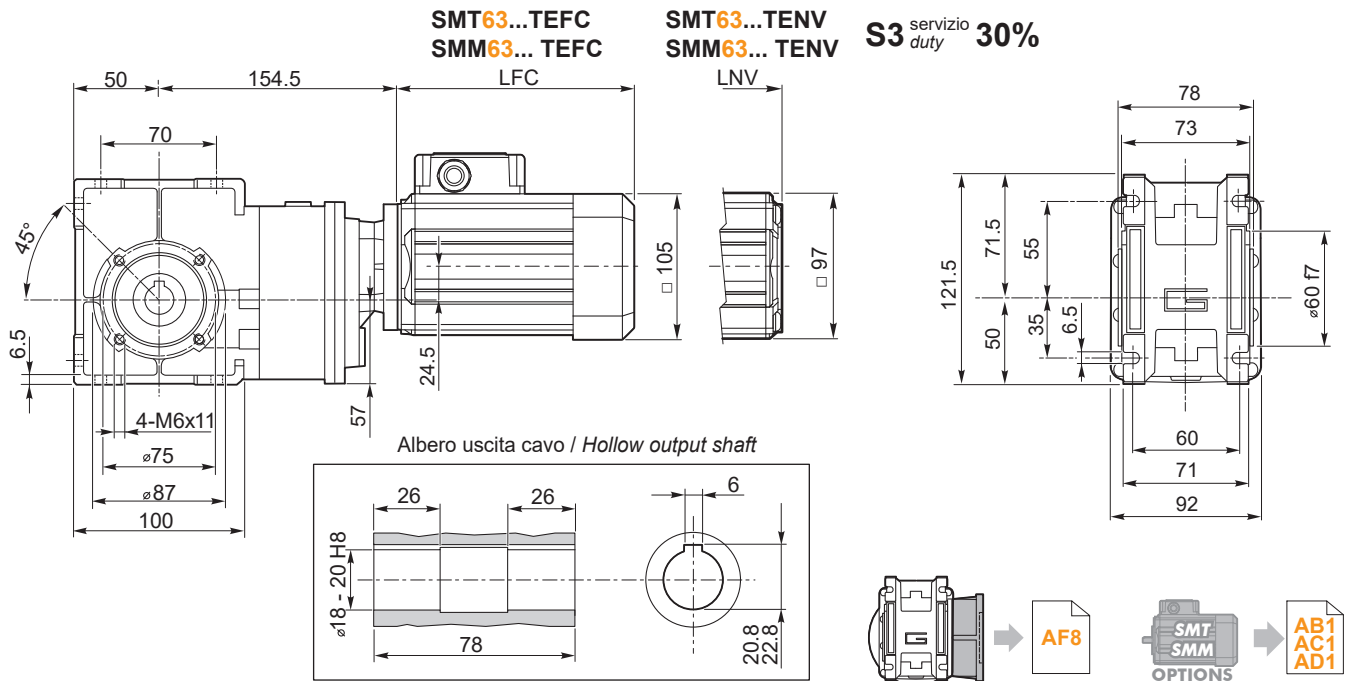

SMT	LFC	LNV	Kg	
6324	165.5	138.5	7.7	
6334	180.5	153.5	8.4	
6344	205.5	178.5	9.6	

SMM	LFC	LNV	Kg	
6324	180.5	153.5	8.5	
6334	205.5	178.5	9.7	

**Nota:**  
il condensatore sarà fornito a corredo

**Note:**  
the capacitor will be supplied separately

CMB 402 U

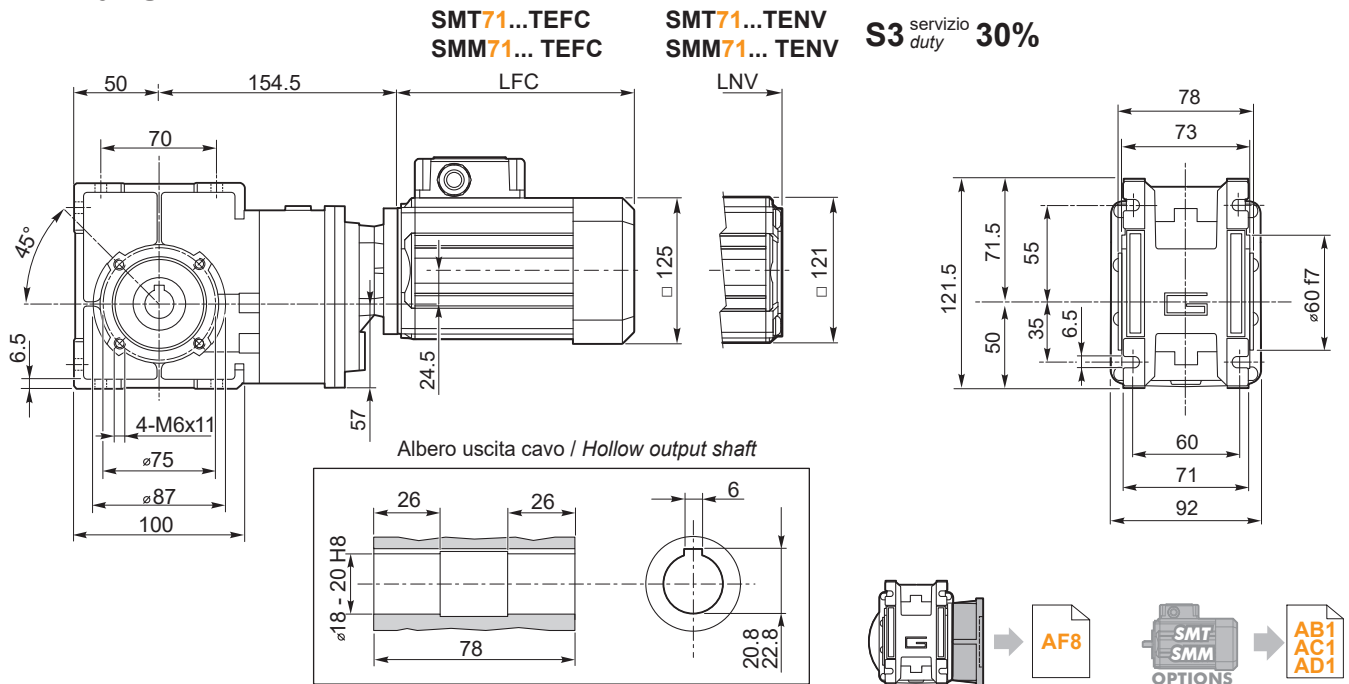

SMT	LFC	LNV	Kg	
7124	174	145.5	9.9	
7134	189	160.5	11	
7144	214	185.5	12.7	

SMM	LFC	LNV	Kg	
7124	189	160.5	10.6	
7134	214	185.5	12.6	

**Nota:**  
il condensatore sarà fornito a corredo

**Note:**  
the capacitor will be supplied separately

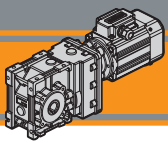

**CMB**

Motoriduttori CA ad assi ortogonali  
AC Helical bevel gearmotors

**MINI** TECNO

**CMB402/ F...** Flange uscita / Output flanges

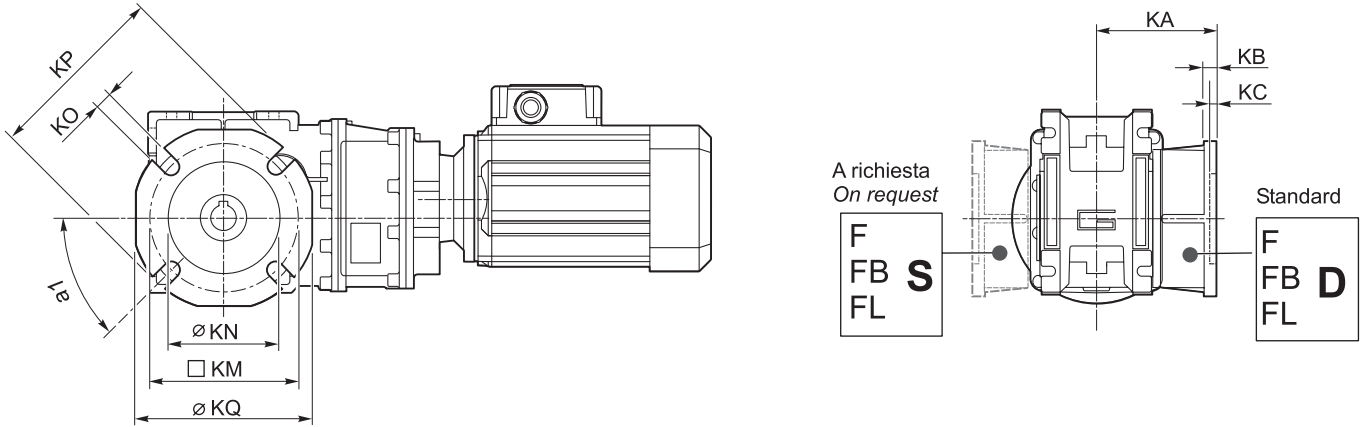

CMB	Flange uscita / Output flanges																										
	F					FL					FB																
	a <sub>1</sub>	KA	KB	KC	KM	KN H8	KO	KP	KQ	a <sub>1</sub>	KA	KB	KC	KM	KN H8	KO	KP	KQ	a <sub>1</sub>	KA	KB	KC	KM	KN H8	KO	KP	KQ
<b>402</b>	45°	67	7.5	4.5	80-95	60	9	110	95	45°	97	7.5	4.5	80-95	60	9	110	95	45°	80	8.5	5	115-125	95	9.5	140	112

**Accessori**

**Accessories**

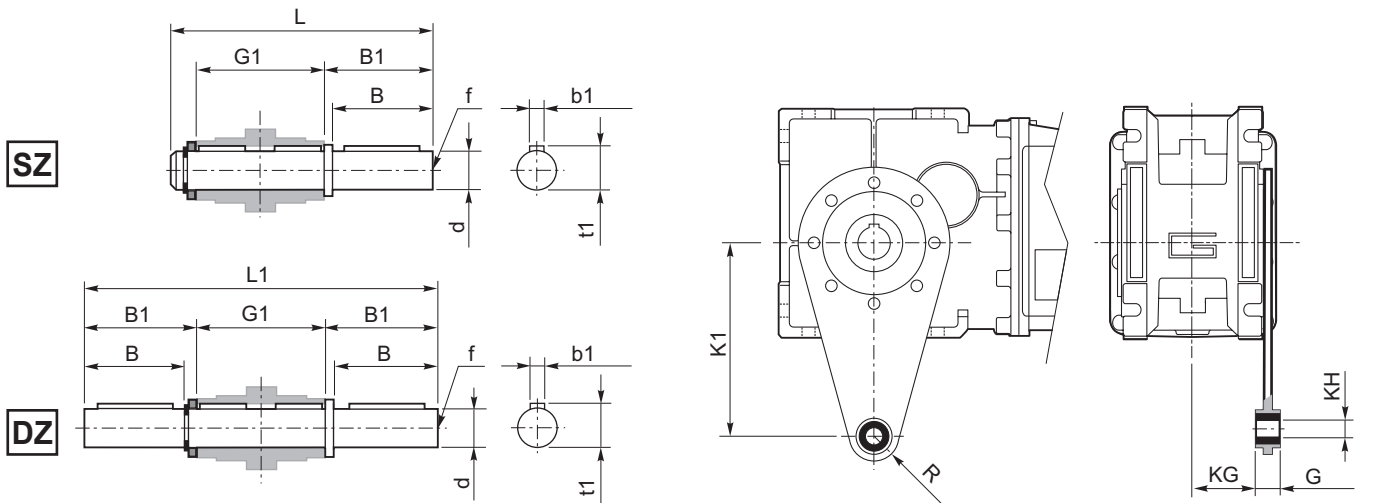

Albero lento / Output shaft

CMB	d h7	B	B1	G1	L	L1	f	b1	t1
<b>402</b>	18	40	43	78	128	164	M6	6	20.5

Braccio di reazione / Torque arm

CMB	K1	G	KG	KH	R
<b>402</b>	100	14	31	10	18

**SC - Safety cover**

**WD - Kit washdown cover**

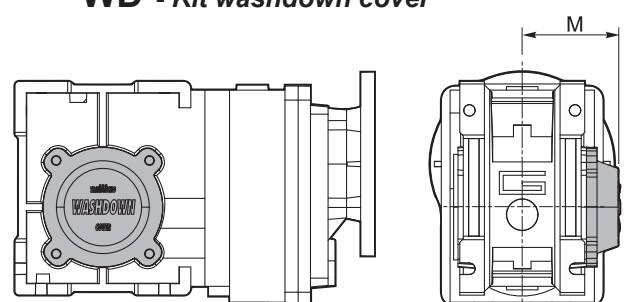
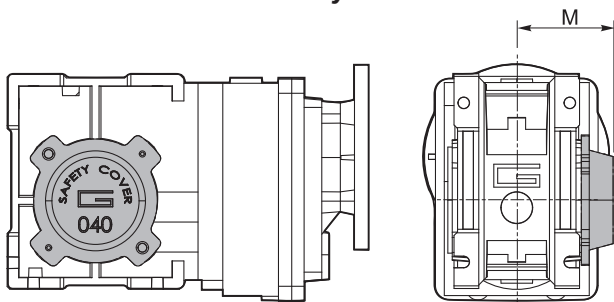

CMB	M
<b>402</b>	54.5

CMB	M
<b>402</b>	55.5

**MINI**  **TECNO**™  
**small** but strong

# KFT105 - FT

Motoriduttori CA pendolari  
AC Helical parallel gearmotors

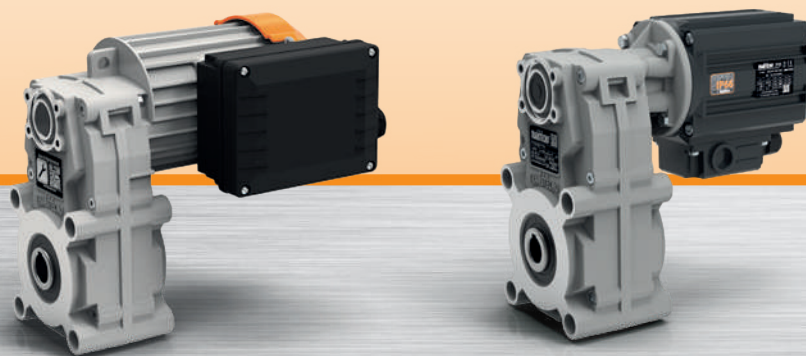

**MINI**  **TECNO**™ brand of  
**TRANSTECNO**®



AC



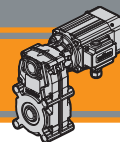

<b>Indice</b>	<b>Index</b>	Pag. Page
Caratteristiche tecniche	<i>Technical features</i>	<b>AG2</b>
Designazione	<i>Classification</i>	<b>AG2</b>
Sensi di rotazione	<i>Direction of rotation</i>	<b>AG3</b>
Simbologia	<i>Symbols</i>	<b>AG3</b>
Lubrificazione	<i>Lubrication</i>	<b>AG3</b>
Carichi radiali	<i>Radial loads</i>	<b>AG4</b>
Motori applicabili	<i>Motor adapters</i>	<b>AG4</b>
Dati tecnici	<i>Technical data</i>	<b>AG5</b>
Dati tecnici elettrici	<i>Electrical technical data</i>	<b>AG7</b>
Normative di riferimento	<i>Reference standards</i>	<b>AG7</b>
Dimensioni	<i>Dimensions</i>	<b>AG8</b>

Questa sezione annulla e sostituisce ogni precedente edizione o revisione. Qualora questa sezione non Vi sia giunta in distribuzione controllata, l'aggiornamento dei dati ivi contenuto non è assicurato. **In tal caso la versione più aggiornata è disponibile sul nostro sito internet [www.transtecno.com](http://www.transtecno.com)**

*This section replaces any previous edition and revision. If you obtained this catalogue other than through controlled distribution channels, the most up to date content is not guaranteed. In this case the latest version is available on our web site [www.transtecno.com](http://www.transtecno.com)*

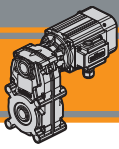

**KFT105  
FT**

**Motoriduttori CA pendolari  
AC Helical parallel gearmotors**



**Caratteristiche tecniche**

**Technical features**

Le caratteristiche principali dei motoriduttori KFT e FT sono:

*KFT and FT gearmotor range has the following main features:*

- Costruzione compatta
- Motorizzazioni in corrente alternata monofase e trifase
- Carcassa motore SMT e SMM estrusa in alluminio anodizzato nero
- Carcasse dei riduttori in pressofusione di alluminio
- Motore elettrico SMT e SMM con grado di protezione IP66
- Lubrificazione permanente con olio sintetico
- Ingranaggi cilindrici a denti elicoidali, induriti e rettificati
- Disponibili sia nella versione ventilata TEFC (servizio S1) che non ventilata TENV (servizio S3)
- Protezione termica PTO 150°C per la taglia motore 56.
- SMT56 adatto al funzionamento con alimentazione da inverter
- SMT e SMM Disponibili nelle versioni autofrenante, servoven-tilata e con certificazione UL.
- Versione KFT105 con motore monofase integrato

- *Compact design*
- *AC single phase and three phase motors available*
- *SMT and SMM motors extruded aluminum housing black ano-dized*
- *Gearbox die-cast aluminum housing*
- *SMT and SMM electric motors in IP66 protection Standard*
- *Permanent synthetic oil long-life lubrication*
- *Ground-hardened helical gears*
- *Fan cooled TEFC (duty S1) and not ventilated TENV (duty S3) versions available*
- *PTO 150°C thermal protection for motor size 56.*
- *SMT56 is suitable for inverter duty*
- *Brake motors, forced ventilation motors and UL compliance versions available for SMT and SMM motors.*
- *KFT105 version with integrated single motor phase*

**KFT105**

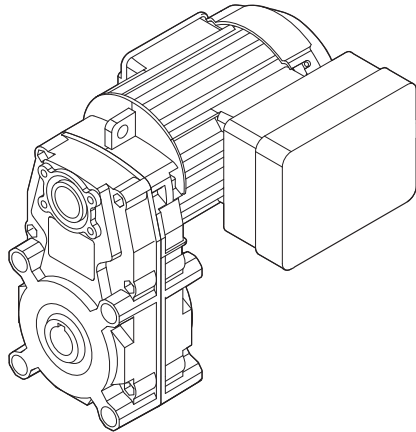

**FT105**

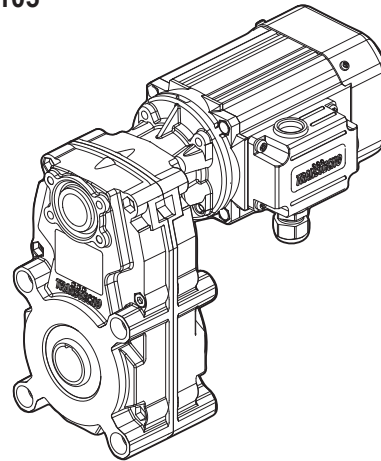

**Designazione**

**Classification**

RIDUTTORE / GEARBOX				
<b>KFT</b>	<b>105/3</b>	<b>U</b>	<b>88.87</b>	<b>O20</b>
Tipo Type	Grandezza Size	Versione Version	Rapporto Ratio	Albero cavo uscita Hollow output shaft
<b>KFT</b> 	<b>105/3</b> <b>105/4</b>	<b>U...</b> <b>F...</b>	vedi tabelle see tables	vedi tabelle see tables

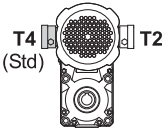
MOTORE / MOTOR						
<b>40W</b>	<b>4p</b>	<b>3ph</b>	<b>230/400V</b>	<b>50Hz</b>	<b>T1</b>	<b>TEFC</b>
Potenza Power	Poli Poles	Fasi Phases	Tensione Voltage	Frequenza Frequency	Pos. morsetti- Terminal box pos.	Ventilazione Fan cooling
vedi tabelle see tables	<b>4p</b>	<b>1ph</b> <b>3ph</b>	<b>230V</b> ... <b>230/400V</b> ...	<b>50Hz</b> <b>60Hz</b>		<b>TEFC</b> <b>TENV</b>

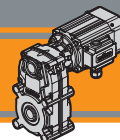
**Designazione**
**Classification**

RIDUTTORE / GEARBOX						
<b>FT</b>	<b>105/3</b>	<b>U</b>	<b>77.07</b>	<b>O20</b>	<b>56</b>	<b>B14</b>
Tipo Type	Grandezza Size	Versione Version	Rapporto Ratio	Albero cavo uscita Hollow output shaft	IEC 	Forma costruttiva Version
<b>FT</b> 	<b>105/3</b> <b>105/4</b>	<b>U...</b>	vedi tabelle see tables	vedi tabelle see tables	<b>56</b>	<b>B14</b>

MOTORE TRIFASE / THREE PHASE MOTOR										
<b>SMT</b>	<b>56</b>	<b>4</b>	<b>4</b>	<b>0.18 kW</b>	<b>B14</b>	<b>230-400 V</b>	<b>50 Hz</b>	<b>TEFC</b>	<b>BR</b>	<b>T1</b>
Tipo Type	Grandezza Size	Indicativo potenza Power coefficient	Poli Poles	Potenza Power	Forma costruttiva Version	Tensione Voltage	Frequenza Frequency	Ventilazione Fan cooling	Opzioni Options	Pos. Morsettiera Terminal box pos.
<b>SMT</b> 	Vedere tab. See tab.	<b>1-2-3-4-5</b>	<b>4</b>	<b>0.04 kW</b> ... <b>0.25 kW</b>	<b>B14</b>	<b>230-400 V</b>  <b>460V</b>	<b>50Hz</b>  <b>60Hz</b>	<b>TEFC</b>  <b>TENV</b>	 <b>AB1</b> <b>AC1</b> <b>AD1</b>	<b>T1 (Std)</b>  <b>T4</b> <b>T2</b> <b>T3</b>

MOTORE MONOFASE / SINGLE PHASE MOTOR										
<b>SMM</b>	<b>56</b>	<b>4</b>	<b>4</b>	<b>0.18 kW</b>	<b>B14</b>	<b>230 V</b>	<b>50 Hz</b>	<b>TEFC</b>	<b>UL-CSA</b>	<b>T1</b>
Tipo Type	Grandezza Size	Indicativo potenza Power coefficient	Poli Poles	Potenza Power	Forma costruttiva Version	Tensione Voltage	Frequenza Frequency	Ventilazione Fan cooling	Opzioni Options	Pos. Morsettiera Terminal box pos.
<b>SMM</b> 	Vedere tab. See tab.	<b>1-2-3-4</b>	<b>4</b>	<b>0.04 kW</b> ... <b>0.18 kW</b>	<b>B14</b>	<b>230V</b>	<b>50Hz</b>	<b>TEFC</b>  <b>TENV</b>	 <b>AD1</b>	<b>T1 (Std)</b>  <b>T4</b> <b>T2</b> <b>T3</b>

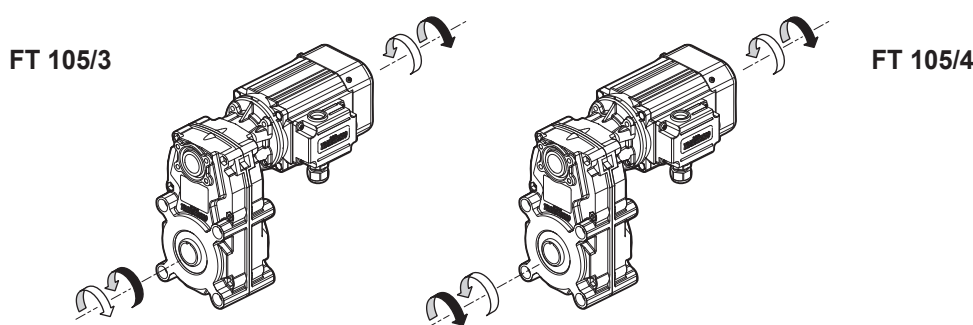
**Sensi di rotazione**
**Direction of rotation**

**Simbologia**
**Symbols**

$n_1$	[min <sup>-1</sup> ]	Velocità in ingresso / <i>Input speed</i>
$n_2$	[min <sup>-1</sup> ]	Velocità in uscita / <i>Output speed</i>
$i$		Rapporto di riduzione / <i>Ratio</i>
$P_1$	[kW]	Potenza in entrata / <i>Input power</i>
$M_2$	[Nm]	Coppia nominale in uscita in funzione di $P_1$ / <i>Output torque referred to <math>P_1</math></i>
$P_{n1}$	[kW]	Potenza nominale in entrata / <i>Nominal input power</i>
$M_{n2}$	[Nm]	Coppia nominale in uscita in funzione di $P_{n1}$ / <i>Nominal output torque referred to <math>P_{n1}</math></i>
$sf$		Fattore di servizio / <i>Service factor</i>
$R_2$	[N]	Carico radiale ammissibile in uscita / <i>Permitted output radial load</i>
$A_2$	[N]	Carico assiale ammissibile in uscita / <i>Permitted output axial load</i>

**Lubrificazione**
**Lubrication**

Tutti i motoriduttori sono forniti completi di lubrificante sintetico viscosità 320, pertanto possono essere installati in qualunque posizione di montaggio e non necessitano di manutenzione.

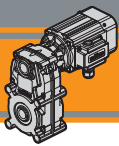
*Permanent synthetic oil long-life lubrication ( viscosity grade 320) makes it possible to use the gearmotors in all mounting positions; for this reason they can be installed in any assembly position and do not require maintenance.*



**Carichi radiali**

**Radial loads**

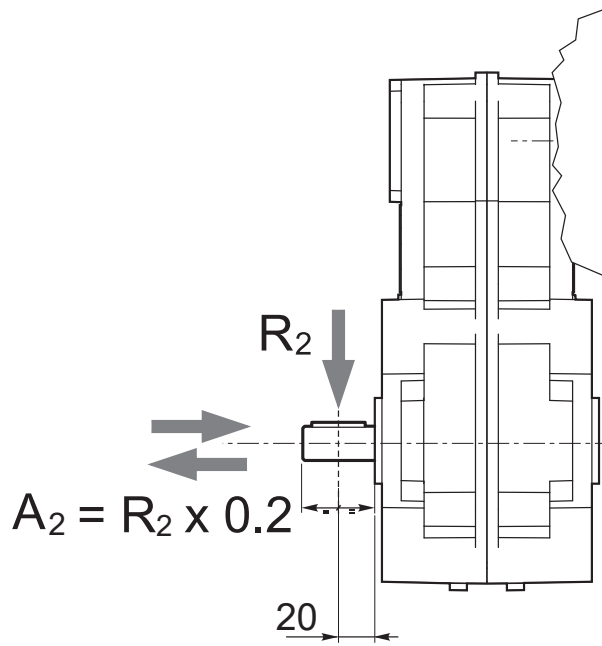

$n_2$ [min <sup>-1</sup> ]	$R_2$ [N]
	KFT105 FT105
70	1500
40	1700
30	1850
20	2000
10	2000
5	2000

Quando il carico radiale risultante non è applicato sulla mezzeria dell'albero occorre calcolare quello effettivo con la seguente formula:

When the resulting radial load is not applied on the centre line of the shaft it is necessary to calculate the effective load with the following formula:

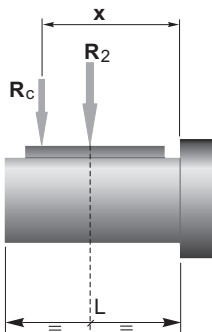

	KFT105 FT105
<b>a</b>	82
<b>b</b>	62
$R_{2MAX}$	2000

$$R_c = \frac{R_2 \cdot a}{(b + x)} \leq R_{2MAX}$$

*a, b = valori riportati nella tabella*  
*a, b = values given in the table*

$$R \leq R_c$$

**Motori applicabili**

**IEC Motor adapters**

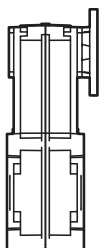
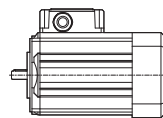

		SMT		SMM	
		5014	5624	5014	5624
		5024	5634	5024	5634
		5034	5644	5034	5644
		5044	5654		
<b>FT</b>	<b>105/3</b>	20.57 - 315.05			
<b>FT</b>	<b>105/4</b>	368.19 - 929.4			

20.57 - 929.4

Rapporti di riduzione *i*  
Ratio *i*

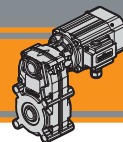

### Dati tecnici

### Technical data

$P_1$ [kW]	$n_2$ [min <sup>-1</sup> ]	$M_2$ [Nm]	sf	$M_n$ [Nm]	i	
---------------	-------------------------------	---------------	----	---------------	---	--

$P_1$ [kW]	$n_2$ [min <sup>-1</sup> ]	$M_2$ [Nm]	sf	$M_n$ [Nm]	i	
---------------	-------------------------------	---------------	----	---------------	---	--

#### 0.025

68	3	12.1	40	20.57	KFT105/3
42	5	9.4	50	33.32	
32	7	9.1	65	44.36	
26	9	7.4	65	54.87	
19	12	5.6	65	71.84	
18	12	5.3	65	77.07	
16	14	4.6	65	88.87	
11	20	3.2	65	124.81	
7.7	29	2.2	65	181.35	
6.2	36	1.8	65	224.32	
4.4	51	1.3	65	315.05	
3.8	58	1.1	65	368.19	KFT105/4
2.6	84	0.8	65	534.98	
2.1	104	0.6	65	661.76	
1.5	120	0.5	65	929.40	

#### 0.09

68	12	3.4	40	20.57	KFT105/3
42	19	2.6	50	33.32	
32	26	2.5	65	44.36	
26	32	2.1	65	54.87	
19	41	1.6	65	71.84	
18	44	1.5	65	77.07	
16	51	1.3	65	88.87	
11	72	0.9	65	124.81	
7.7	105	0.6	65	181.35	
6.2	110	0.6	65	224.32	

#### 0.04

68	5	7.6	40	20.57	KFT105/3
42	9	5.9	50	33.32	
32	11	5.7	65	44.36	
26	14	4.6	65	54.87	
19	18	3.5	65	71.84	
18	20	3.3	65	77.07	
16	23	2.9	65	88.87	
11	32	2.0	65	124.81	
7.7	47	1.4	65	181.35	
6.2	58	1.1	65	224.32	
4.4	81	0.8	65	315.05	
3.8	92	0.7	65	368.19	KFT105/4
2.6	120	0.5	65	534.98	
2.1	120	0.5	65	661.76	

#### 0.12

68	16	2.5	40	20.57	KFT105/3
42	26	2.0	50	33.32	
32	34	1.9	65	44.36	
26	42	1.5	65	54.87	
19	55	1.2	65	71.84	
18	59	1.1	65	77.07	
16	68	1.0	65	88.87	
11	96	0.7	65	124.81	
7.7	110	0.6	65	181.35	

#### 0.06

68	8	5.1	40	20.57	KFT105/3
42	13	3.9	50	33.32	
32	17	3.8	65	44.36	
26	21	3.1	65	54.87	
19	28	2.4	65	71.84	
18	30	2.2	65	77.07	
16	34	1.9	65	88.87	
11	48	1.4	65	124.81	
7.7	70	0.9	65	181.35	
6.2	86	0.8	65	224.32	
4.4	110	0.6	65	315.05	
3.8	120	0.5	65	368.19	KFT105/4



N.B.



Verificare sempre che la coppia  $M_2$  utilizzata non ecceda il valore indicato nelle caselle in grigio

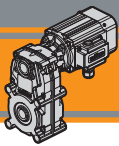

N.B.



Please check that the output torque  $M_2$  does not exceed the value in the grey areas



**FT****Motoriduttori CA pendolari**  
**AC Helical parallel gearmotors****Dati tecnici****Technical data**



P <sub>1</sub> [kW]	n <sub>2</sub> [min <sup>-1</sup> ]	M <sub>2</sub> [Nm]	sf	i		
<b>0.04</b>						
SMT5014	<b>68</b>	5	7.6	20.57	<b>FT105/3</b>	
SMM5014	<b>42</b>	9	5.9	33.32		
(1400 min <sup>-1</sup> )	<b>32</b>	11	5.7	44.36		
	<b>26</b>	14	4.6	54.87		
	<b>19</b>	18	3.5	71.84		
	<b>18</b>	20	3.3	77.07		
	<b>16</b>	23	2.9	88.87		
	<b>11</b>	32	2.0	124.81		
	<b>7.7</b>	47	1.4	181.35		
	<b>6.2</b>	58	1.1	224.32		
	<b>4.4</b>	81	0.8	315.05		
	<b>3.8</b>	92	0.7	368.19		<b>FT105/4</b>
	<b>2.6</b>	120	0.5	534.98		
	<b>2.1</b>	120	0.5	661.76		

P <sub>1</sub> [kW]	n <sub>2</sub> [min <sup>-1</sup> ]	M <sub>2</sub> [Nm]	sf	i	
<b>0.12</b>					
SMT5044	<b>68</b>	16	2.5	20.57	<b>FT105/3</b>
SMT5634	<b>42</b>	26	2.0	33.32	
SMM5624	<b>32</b>	34	1.9	44.36	
(1400 min <sup>-1</sup> )	<b>26</b>	42	1.5	54.87	
	<b>19</b>	55	1.2	71.84	
	<b>18</b>	59	1.1	77.07	
	<b>16</b>	68	1.0	88.87	
	<b>11</b>	96	0.7	124.81	
	<b>7.7</b>	110	0.6	181.35	

P <sub>1</sub> [kW]	n <sub>2</sub> [min <sup>-1</sup> ]	M <sub>2</sub> [Nm]	sf	i	
<b>0.06</b>					
SMT5024	<b>68</b>	8	5.1	20.57	<b>FT105/3</b>
SMM5024	<b>42</b>	13	3.9	33.32	
(1400 min <sup>-1</sup> )	<b>32</b>	17	3.8	44.36	
	<b>26</b>	21	3.1	54.87	
	<b>19</b>	28	2.4	71.84	
	<b>18</b>	30	2.2	77.07	
	<b>16</b>	34	1.9	88.87	
	<b>11</b>	48	1.4	124.81	
	<b>7.7</b>	70	0.9	181.35	
	<b>6.2</b>	86	0.8	224.32	
	<b>4.4</b>	92	0.7	315.05	

P <sub>1</sub> [kW]	n <sub>2</sub> [min <sup>-1</sup> ]	M <sub>2</sub> [Nm]	sf	i	
<b>0.18</b>					
SMT5644	<b>68</b>	24	1.7	20.57	<b>FT105/3</b>
SMM5644	<b>42</b>	38	1.3	33.32	
(1400 min <sup>-1</sup> )	<b>32</b>	51	1.3	44.36	
	<b>26</b>	63	1.0	54.87	
	<b>19</b>	83	0.8	71.84	
	<b>18</b>	89	0.7	77.07	
	<b>16</b>	92	0.7	88.87	
	<b>11</b>	110	0.6	124.81	

P <sub>1</sub> [kW]	n <sub>2</sub> [min <sup>-1</sup> ]	M <sub>2</sub> [Nm]	sf	i	
<b>0.25</b>					
SMT5654	<b>68</b>	33	1.2	20.57	<b>FT105/3</b>
(1400 min <sup>-1</sup> )	<b>42</b>	53	0.9	33.32	
	<b>32</b>	71	0.9	44.36	

P <sub>1</sub> [kW]	n <sub>2</sub> [min <sup>-1</sup> ]	M <sub>2</sub> [Nm]	sf	i	
<b>0.09</b>					
SMT5034	<b>68</b>	12	3.4	20.57	<b>FT105/3</b>
SMM5034	<b>42</b>	19	2.6	33.32	
SMT5624	<b>32</b>	26	2.5	44.36	
SMM5624	<b>26</b>	32	2.1	54.87	
(1400 min <sup>-1</sup> )	<b>19</b>	41	1.6	71.84	
	<b>18</b>	44	1.5	77.07	
	<b>16</b>	51	1.3	88.87	
	<b>11</b>	72	0.9	124.81	
	<b>7.7</b>	105	0.6	181.35	
	<b>6.2</b>	110	0.6	224.32	

N.B.  
Verificare sempre che la coppia M<sub>2</sub> utilizzata non ecceda il valore indicato nelle caselle in grigio  
N.B.  
*Please check that the output torque M<sub>2</sub> does not exceed the value in the grey areas*



Motori Motors	SMT		SMM	
		5014 5024 5034 5044	5624 5634 5644 5654	5014 5024 5034
IEC	56 B14		56 B14	

**Dati tecnici elettrici****Electrical technical data**

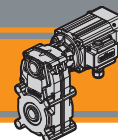
**Dati tecnici elettrici - KFT 105**
**KFT 105 - Electrical technical data**

1 Ph	P <sub>n</sub> [W]	V [V]	F [Hz]	I <sub>n</sub> [A]	I <sub>s</sub> [A]	cosØ	C [µF]	TEFC Servizio Duty	TENV Servizio Duty
	25	230	50	0.42	0.84	0.87	6.0	S1 100%	S3 30%
	40			0.47	0.86	0.91	6.3		
	60			0.74	1.50	0.82	8.0		
	90			0.82	1.60	0.93	12.5		
	120			1.38	3.10	0.81	14.0		

3 Ph	P <sub>n</sub> [W]	V [V]	F [Hz]	I <sub>n</sub> [A]	I <sub>s</sub> [A]	cosØ	TEFC Servizio Duty	TENV Servizio Duty
	25	230	50	0.41	0.97	0.54	S1 100%	S3 30%
		400						
	40	230	50	0.43	0.97	0.62		
		400						
	60	230	50	0.72	1.80	0.48		
		400						
	90	230	50	0.74	1.80	0.60		
		400						
	120	230	50	1.34	3.70	0.50		
		400						

**Nota:**

Classe di rendimento Standard IE1

**Note:**

Standard efficiency IE1

**Normative di riferimento**
**Reference standards**

	Europe EN	World IEC	Italy CEI
<b>Requisiti generali per macchine elettriche</b> <i>General requirements electrical machines</i>	EN 60034-1:2010	IEC 60034-1:2010	CEI EN 60034-1:2010
<b>Classificazione del grado di protezione</b> <i>Classification degree of protection provided by enclosures</i>	EN 60034-5:2001	IEC 60034-5:2001	CEI EN 60034-5:2001
<b>Sistema di raffreddamento</b> <i>Cooling system</i>	EN 60034-6:1993	IEC 60034-6:1993	CEI EN 60034-6:1993
<b>Modalità di montaggio</b> <i>Mounting arrangements</i>	EN 60034-7:1993	IEC 60034-7:1993	CEI EN 60034-7:1993

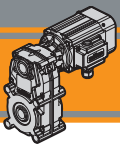

### Dimensioni

### Dimensions

## KFT 105... 25W - 40W - 60W - 90W

### KFT 105...1 Ph...TEFC

### KFT 105...1 Ph...TENV

S3 servizio duty 30%

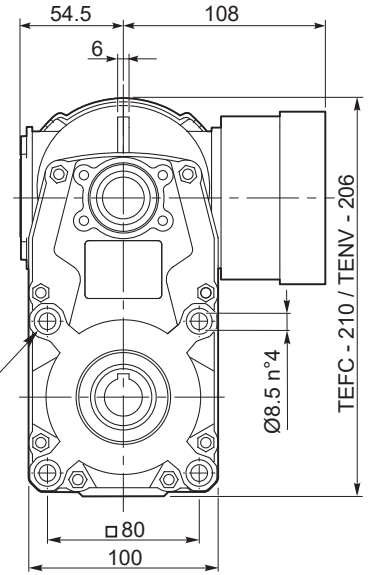
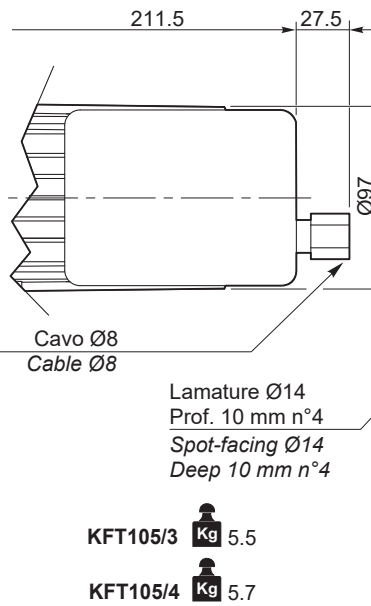
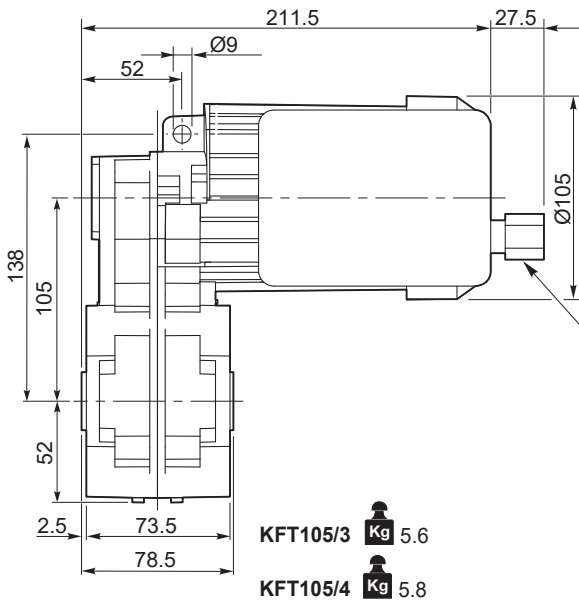

NOTA: Stessi fissaggi da entrambi i lati  
NOTE: Same fixing points in both sides

### KFT 105...3 Ph... TEFC

### KFT 105...3 Ph... TENV

S3 servizio duty 30%

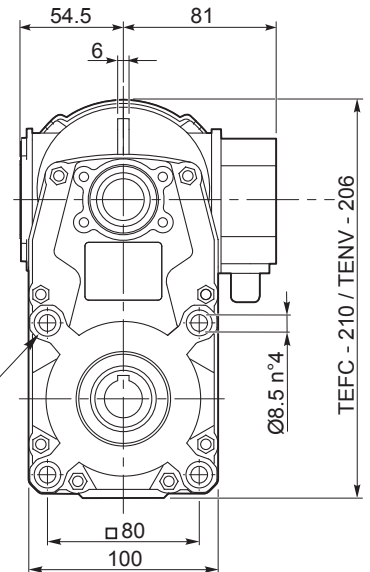
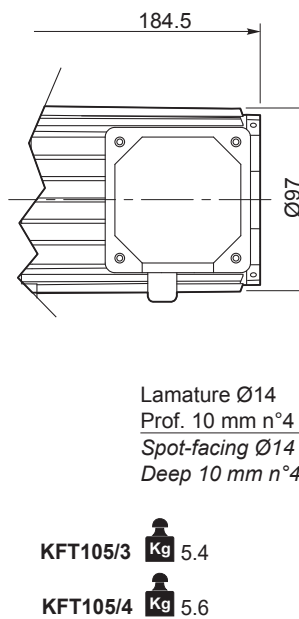
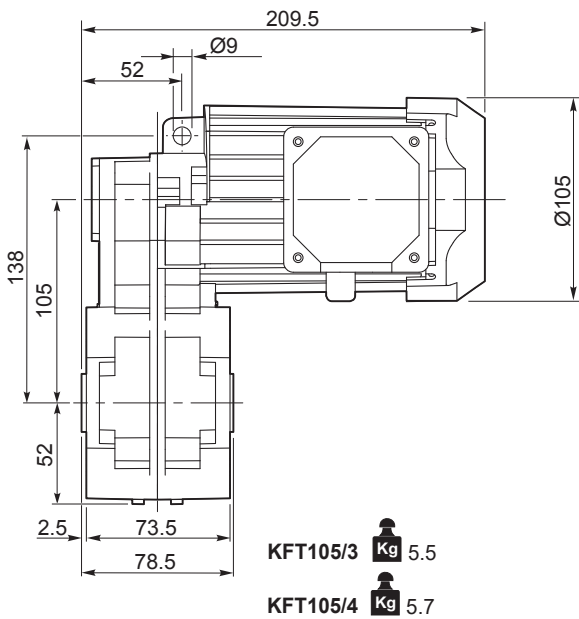

NOTA: Stessi fissaggi da entrambi i lati  
NOTE: Same fixing points in both sides

### O17

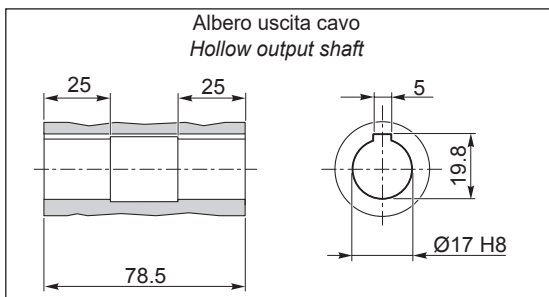

### O20

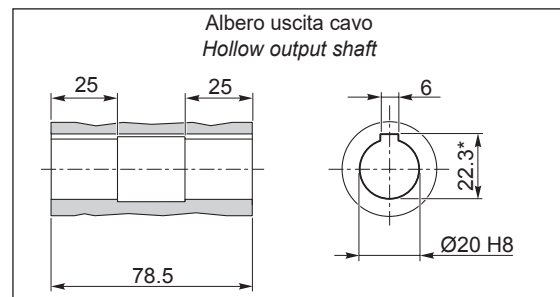

\*Sede linguetta ribassata / Special Keyway

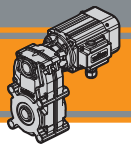

Dimensioni

Dimensions

**KFT 105... 120W**

**KFT 105...1 Ph... TEFC**

**KFT 105...1 Ph...TENV S3 servizio duty 30%**

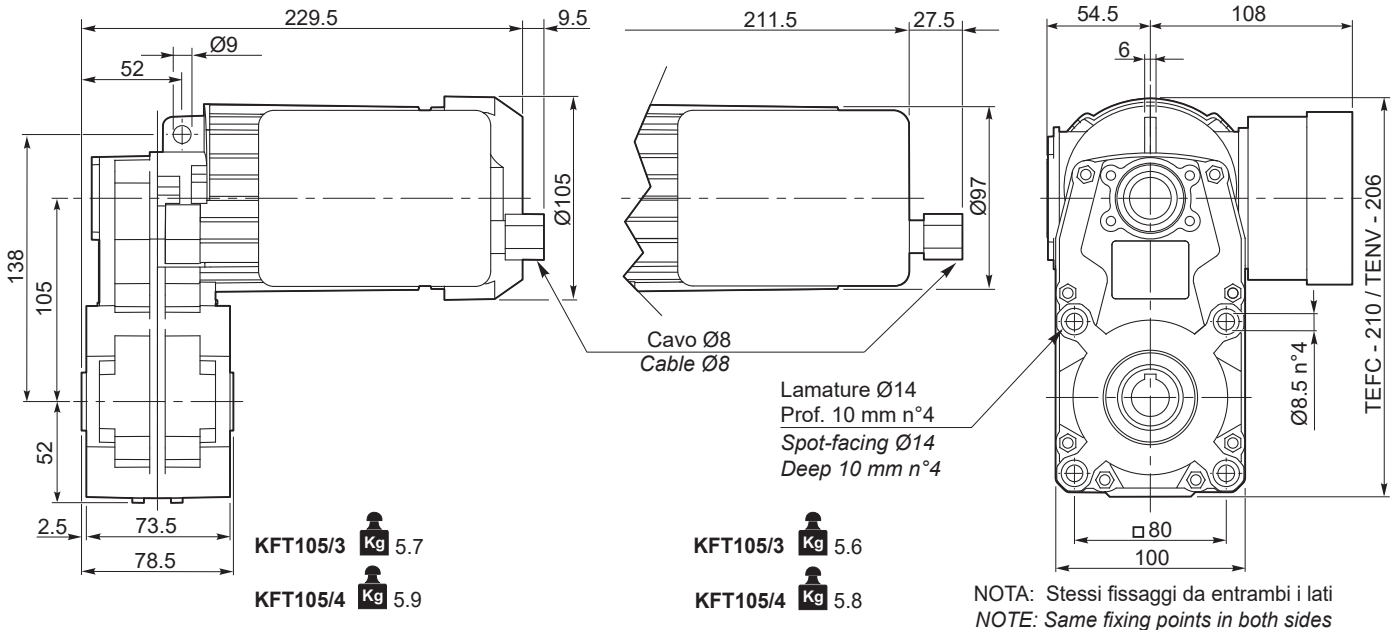

**KFT 105...3 Ph... TEFC**

**KFT 105...3 Ph... TENV S3 servizio duty 30%**

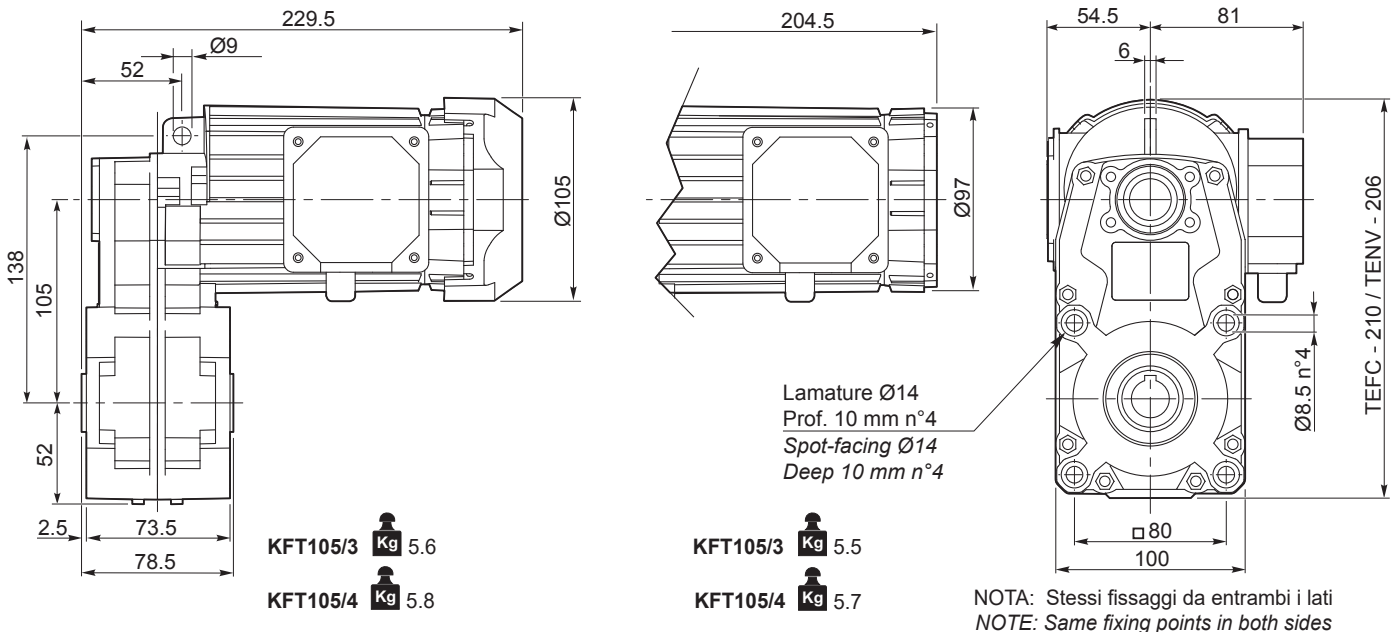

**O17**

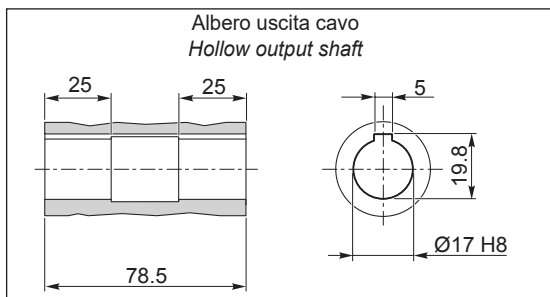

**O20**

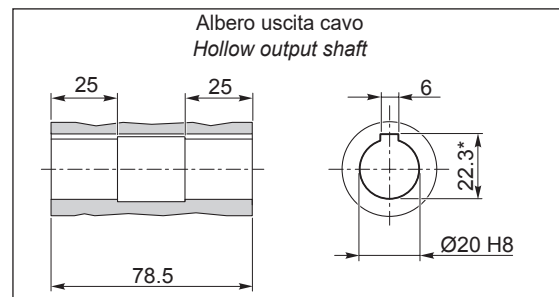

\*Sede linguetta ribassata/ Special Keyway

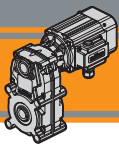
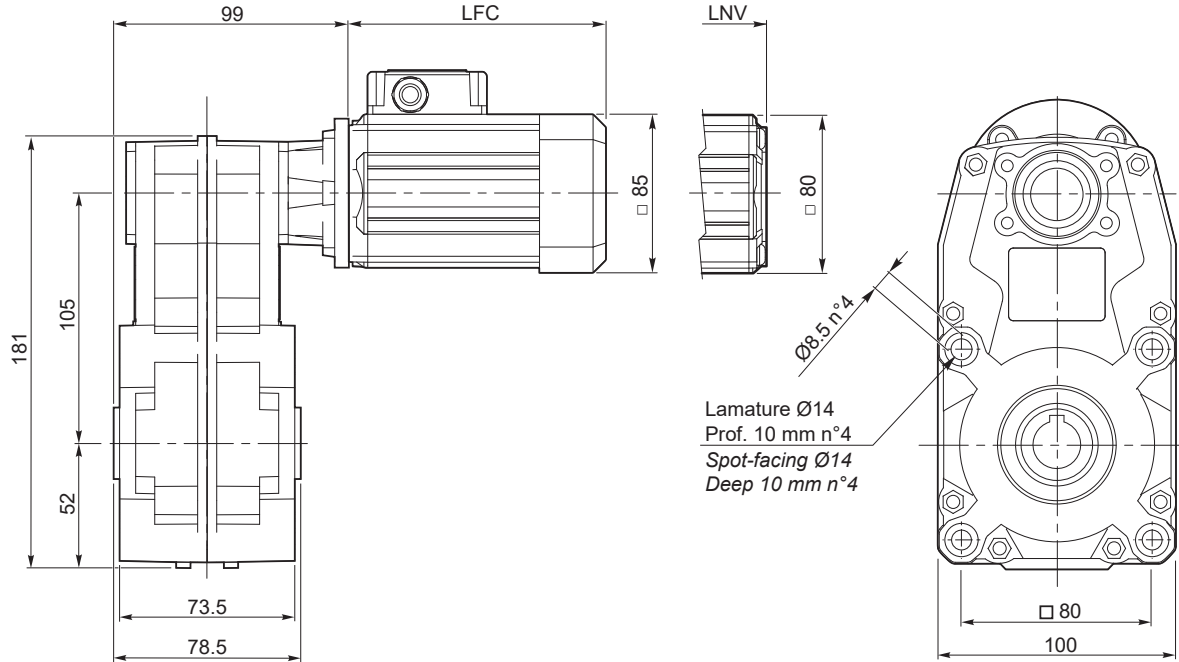
**FT****Motoriduttori CA pendolari  
AC Helical parallel gearmotors****MINI  
TECNO****Dimensioni****Dimensions****FT105 U****FT 105...U****SMT50...TEFC  
SMM50... TEFC****SMT50...TENV  
SMM50... TENV****S3 servizio 30%**  
*duty*

NOTA: Stessi fissaggi da entrambi i lati  
NOTE: Same fixing points in both sides

SMT	LFC	LNV	Kg	
5014	135.5	108.5	6.5	
5024	150.5	123.5	6.9	
5034	175.5	148.5	7.7	
5044	200.5	173.5	8.4	

SMM	LFC	LNV	Kg	
5014	150.5	123.5	6.9	
5024	175.5	148.5	7.7	
5034	200.5	173.5	8.4	

**Nota:**  
il condensatore sarà fornito a corredo  
**Note:**  
the capacitor will be supplied separately

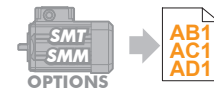
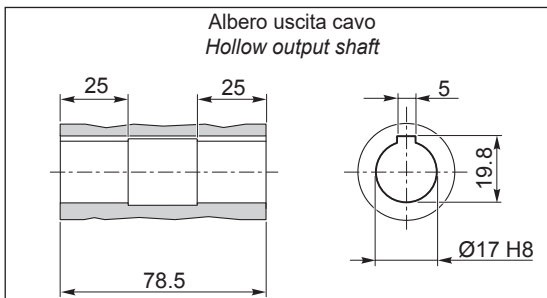
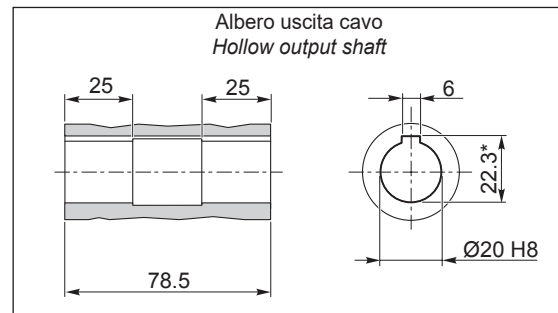
**O17****O20**

\*: Sede linguetta ribassata / Special keyway

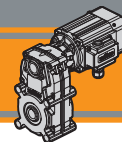

Dimensioni

Dimensions

FT105 U

FT 105...U

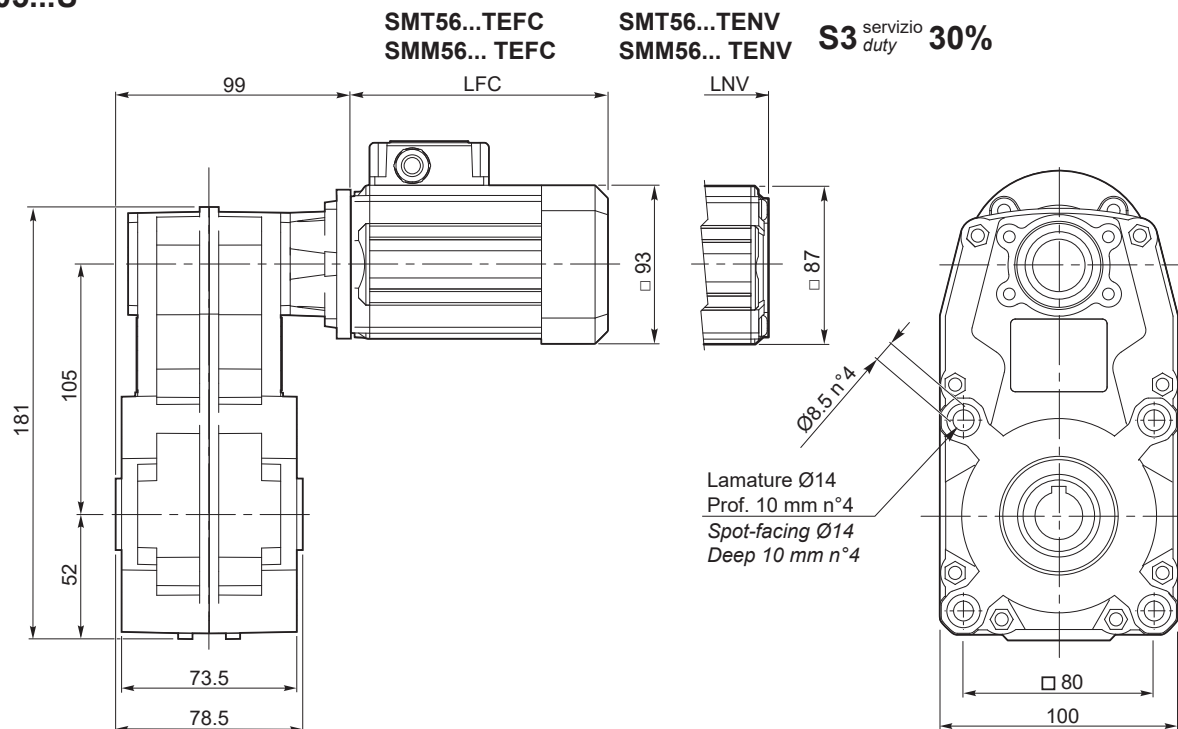

NOTA: Stessi fissaggi da entrambi i lati  
NOTE: Same fixing points in both sides

SMT	LFC	LNV	Kg	
5624	141	117	7	
5634	151	127	7.4	
5644	186	162	8.6	
5654	206	182	9.3	

SMM	LFC	LNV	Kg	
5624	151	127	7.3	
5634	171	147	7.9	
5644	206	182	9.2	

**Nota:**  
il condensatore sarà fornito a corredo  
**Note:**  
the capacitor will be supplied separately



O17

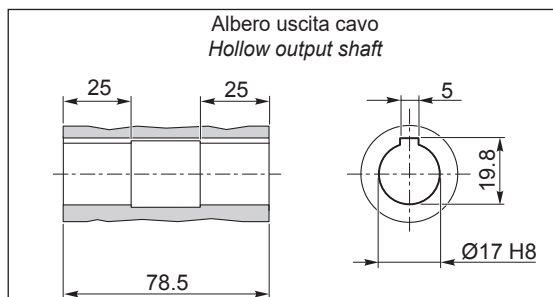

O20

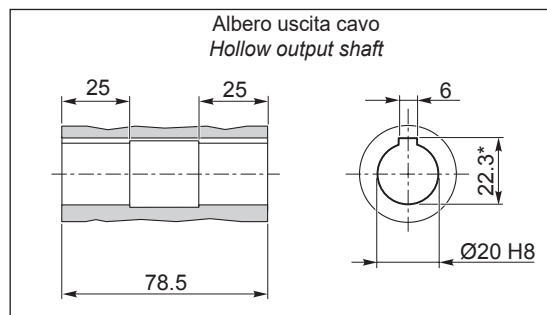

\*: Sede linguetta ribassata / Special keyway



## Motoriduttori CA a vite senza fine AC Wormgearmotors

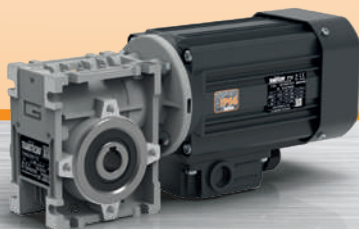



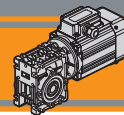

<b>Indice</b>	<b>Index</b>	Pag. Page
Caratteristiche tecniche	<i>Technical features</i>	<b>AH2</b>
Designazione	<i>Classification</i>	<b>AH3</b>
Sensi di rotazione	<i>Direction of rotation</i>	<b>AH4</b>
Simbologia	<i>Symbols</i>	<b>AH4</b>
Lubrificazione	<i>Lubrication</i>	<b>AH4</b>
Carichi radiali	<i>Radial loads</i>	<b>AH5</b>
Dati di dentatura	<i>Toothing data</i>	<b>AH5</b>
Rendimento	<i>Efficiency</i>	<b>AH6</b>
Motori applicabili	<i>Motor adapters</i>	<b>AH6</b>
Dati tecnici	<i>Technical</i>	<b>AH7</b>
Dimensioni	<i>Dimensions</i>	<b>AH10</b>
Opzioni	<i>Options</i>	<b>AH20</b>
Accessori	<i>Accessories</i>	<b>AH20</b>

Questa sezione annulla e sostituisce ogni precedente edizione o revisione. Qualora questa sezione non Vi sia giunta in distribuzione controllata, l'aggiornamento dei dati ivi contenuto non è assicurato. **In tal caso la versione più aggiornata è disponibile sul nostro sito internet [www.transtecno.com](http://www.transtecno.com)**

*This section replaces any previous edition and revision. If you obtained this catalogue other than through controlled distribution channels, the most up to date content is not guaranteed. In this case the latest version is available on our web site [www.transtecno.com](http://www.transtecno.com)*

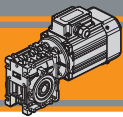

CM  
CMP

## Caratteristiche tecniche

## Technical features

Le caratteristiche principali dei motoriduttori CM e CMP sono:

- Costruzione compatta
- Motorizzazioni in corrente alternata monofase e trifase
- Carcassa motore estrusa in alluminio anodizzato nero
- Carcasse dei riduttori in pressofusione di alluminio
- Motore elettrico AC con grado di protezione IP66
- Lubrificazione permanente con olio sintetico
- Disponibili sia nella versione ventilata TEFC (servizio S1) che non ventilata TENV (servizio S3)
- Protezione termica PTO 150°C per le taglie motore 56, 63 e 71.
- SMT56, SMT63 e SMT71 adatti al funzionamento con alimentazione da inverter
- Disponibili nelle versioni autofrenante, servovenilata e con certificazione UL.

CM and CMP gearmotors range has the following main features:

- Compact design
- AC single phase and three phase motors available
- Motor extruded aluminum housing black anodized
- Gearbox die-cast aluminum housing
- AC electric motor in IP66 protection Standard
- Permanent synthetic oil long-life lubrication
- Fan cooled TEFC (duty S1) and not ventilated TENV (duty S3) versions available
- PTO 150°C thermal protection for motor sizes 56, 63 and 71.
- SMT56, SMT63 and SMT71 are suitable for inverter duty
- Brake motors, forced ventilation motors and UL compliance versions available.

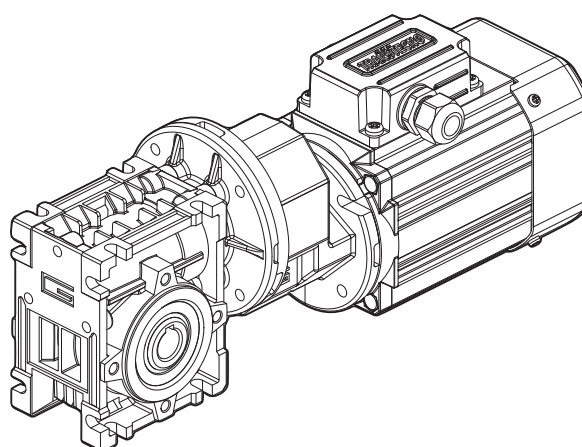
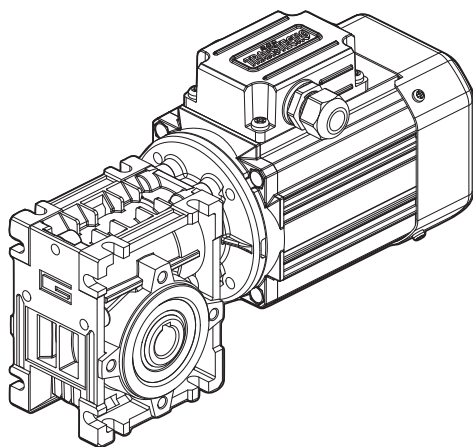

## Designazione

## Classification

### RIDUTTORI A VITE SENZA FINE / WORMGEARBOXES

RIDUTTORE / GEARBOX									
CM	040	U	10	63	B14	SZDX	BRSX	90	VS
Tipo Type	Grandezza Size	Versione riduttore Gearbox Version	Rapporto Ratio	IEC 	Forma costruttiva Version	Albero di uscita Output shaft	Braccio di reazione Torque arm	Angolo Angle	Opzioni Options
	026 026 (D11) 026 (D14) 030 040	U F...	Vedere tabella See tables	56.. 63.. 71..	B14	SZDX SZSX DZ	BRDX BRSX 	0° 90° 180° 270°	VS

### RIDUTTORI A VITE SENZA FINE CON PRECOPPIA / PRE-STAGE WORMGEARBOXES

RIDUTTORE / GEARBOX										
CMP	063/040	U	90	63	B14	SZDX	BRSX	90	P4	VS
Tipo Type	Grandezza Size	Versione Riduttore Gearbox Version	Rapporto Ratio	IEC 	Forma costruttiva Version	Albero di uscita Output shaft	Braccio di reazione Torque arm	Angolo Angle	Pos. di montaggio precoppia Pre stage mounting position	Opzioni Options
	056/030 056/040 063/040	U F...	Vedere tabella See tables	56.. 63..	B5 B14	SZDX SZSX DZ	BRDX BRSX 	0° 90° 180° 270°	P1 P2 P3 (standard) P4	VS

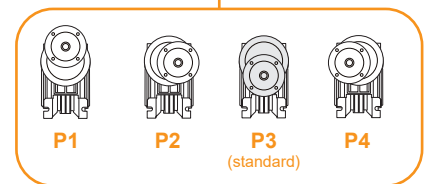

Versione Riduttore  
Gearbox Version

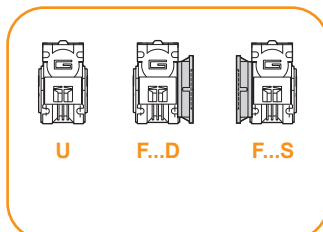

Albero di uscita  
Output shaft

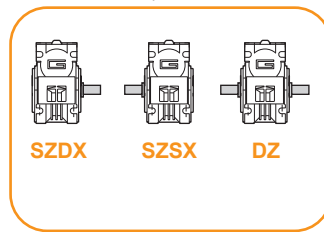

Braccio di reazione  
Torque arm

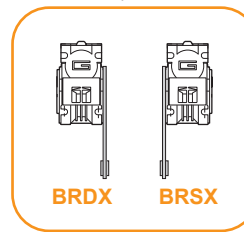

Angolo  
Angle

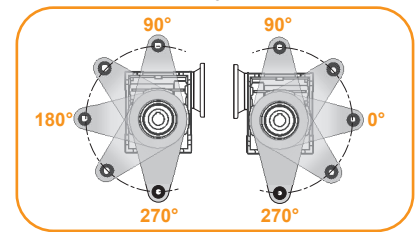

NOTA: il braccio di reazione viene fornito smontato.  
NOTE: the torque arm will be supplied not assembled.

### MOTORE TRIFASE / THREE PHASE MOTOR

SMT	63	2	4	0.18 kW	B14	230-400 V	50 Hz	TEFC	BR	T1
Tipo Type	Grandezza Size	Indicativo potenza Power coefficient	Poli Poles	Potenza Power	Forma costruttiva Version	Tensione Voltage	Frequenza Frequency	Ventilazione Fan cooling	Opzioni Options	Pos. Morsettiera Terminal box pos.
	Vedere tab. See tab.	1-2-3-4-5	4	0.04 kW ... 0.75 kW	B14	230-400 V 460V	50Hz 60Hz	TEFC TENV	 AB1 AC1 AD1	T1 (Std)  T4 T2 T3

### MOTORE MONOFASE / SINGLE PHASE MOTOR

SMM	63	2	4	0.18 kW	B14	230 V	50 Hz	TEFC	UL-CSA	T1
Tipo Type	Grandezza Size	Indicativo potenza Power coefficient	Poli Poles	Potenza Power	Forma costruttiva Version	Tensione Voltage	Frequenza Frequency	Ventilazione Fan cooling	Opzioni Options	Pos. Morsettiera Terminal box pos.
	Vedere tab. See tab.	1-2-3-4	4	0.04 kW ... 0.55 kW	B14	230V	50Hz	TEFC TENV	 AD1	T1 (Std)  T4 T2 T3

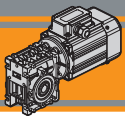

CM  
CMP

Motoriduttori CA a vite senza fine  
AC Wormgearmotors

MINI  
TECNO

## Sensi di rotazione

## Direction of rotation

CM

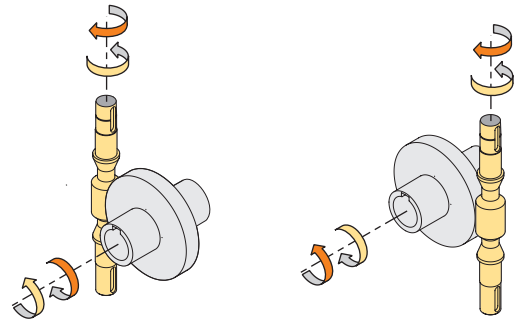
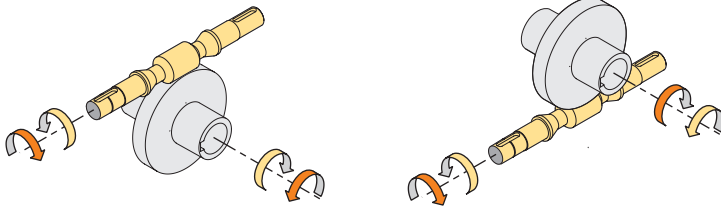

CMP

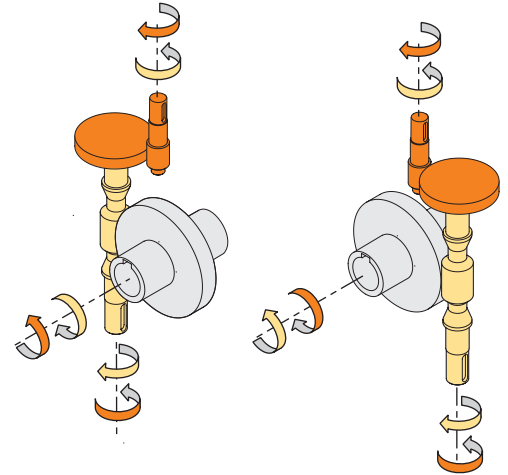
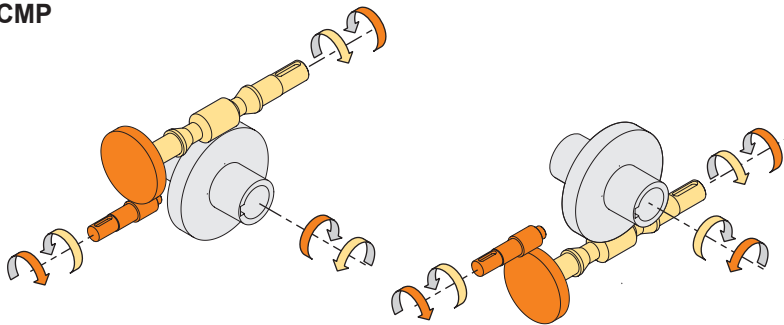

## Simbologia

## Symbols

$n_1$	[ $\text{min}^{-1}$ ]	Velocità in ingresso / <i>Input speed</i>	$R_d$	%	Rendimento dinamico / <i>Dynamic efficiency</i>
$n_2$	[ $\text{min}^{-1}$ ]	Velocità in uscita / <i>Output speed</i>	$A_2$	[N]	Carico assiale ammissibile in uscita / <i>Permitted output axial load</i>
$i$		Rapporto di riduzione / <i>Ratio</i>	$R_s$	%	Rendimento statico / <i>Static efficiency</i>
$P_1$	[kW]	Potenza in entrata / <i>Input power</i>	$R_2$	[N]	Carico radiale ammissibile in uscita / <i>Permitted output radial load</i>
$M_2$	[Nm]	Coppia in uscita in funzione di $P_1$ / <i>Output torque referred to <math>P_1</math></i>	$Z$		Numero di principi della vite / <i>Worm starts</i>
$sf$		Fattore di servizio / <i>Service factor</i>	$\beta$		Angolo d'elica / <i>Helix angle</i>

## Lubrificazione

## Lubrication

I riduttori a vite senza fine della serie CM sono lubrificati a vita con olio sintetico di viscosità 320 e possono essere installati in qualunque posizione di montaggio.

*Permanent synthetic oil long-life lubrication allow to use CM wormgearbox range in all mounting position.*

Carichi radiali

Radial loads

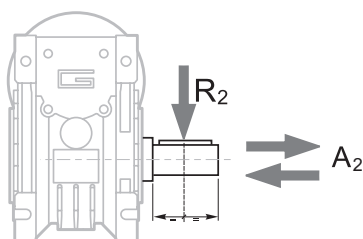

$$A_2 = R_2 \times 0.2$$

n <sub>2</sub> [min <sup>-1</sup> ]	R <sub>2</sub> [N]		
	CM026	CM030	CM040
187	400	674	1264
140	490	743	1392
93	580	851	1596
70	610	936	1754
56	610	1008	1890
47	610	1069	2004
35	610	1179	2210
28	610	1270	2381
23	610	1356	2542
18	610	1471	2759
14	610	1600	3000
		CMP... /030	CMP... /040

Quando il carico radiale risultante non è applicato sulla mezza-  
ria dell'albero occorre calcolare quello effettivo con la seguente  
formula:

When the resulting radial load is not applied on the centre line  
of the shaft it is necessary to calculate the effective load with the  
following formula:

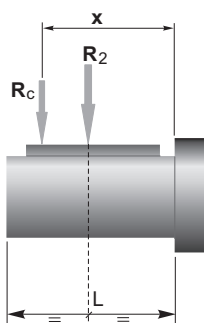

$$R_c = \frac{R_2 \cdot a}{(b + x)} \leq R_{2MAX}$$

$$R \leq R_c$$

a, b = valori riportati nella tabella  
a, b = values given in the table

	CM	CM / CMP	
	026	030	040
a	56	65	84
b	43	50	64
R <sub>2MAX</sub>	610	1600	3000

Dati di dentatura

Toothing data

	Dati della coppia vite- corona Worm wheel data	Rapporto / Ratio											
		5	7.5	10	15	20	25	30	40	50	60	80	100
CM026	Z	6	4	3	2	2		1	1	1	1		
	β	34° 35'	24° 41'	19° 1'	12° 57'	10° 30'		6° 33'	5° 17'	4° 26'	3° 49'		
CM030	Z	6	4	3	2	2	2	1	1	1	1	1	1
	β	27° 4'	24° 28'	18° 50'	12° 49'	10° 23'	8° 43'	6° 29'	5° 14'	4° 23'	3° 46'	2° 57'	2° 25'
CM040	Z	6	4	3	2	2	2	1	1	1	1	1	1
	β	34° 19'	24° 28'	18° 50'	12° 49'	10° 23'	8° 43'	6° 29'	5° 14'	4° 23'	3° 46'	2° 57'	2° 25'

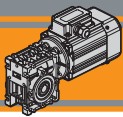

CM  
CMP

Motoriduttori CA a vite senza fine  
AC Wormgearmotors



Rendimento

Efficiency

	$n_1$ [min <sup>-1</sup> ]	Rendimento Efficiency	Rapporto / Ratio											
			5	7.5	10	15	20	25	30	40	50	60	80	100
CM026	2800	Rd	89	87	85	83	80		73	68	64	60		
	1400		87	84	83	78	74		66	61	57	53		
	900		84	83	80	75	71		61	57	52	48		
		Rs	72	71	68	61	56		46	41	36	34		
CM030	2800	Rd	89	88	86	84	81	78	74	70	65	62	57	52
	1400		86	85	84	79	75	72	67	62	58	55	48	43
	900		84	83	81	75	71	68	62	58	53	49	43	39
		Rs	72	67	63	55	50	43	39	35	31	27	23	21
CM040	2800	Rd	90	89	87	84	83	80	77	73	69	66	60	56
	1400		88	86	84	81	78	74	70	65	60	58	52	46
	900		86	84	82	77	74	70	66	60	57	53	46	41
		Rs	74	71	67	60	55	51	45	40	36	32	28	24



Rendimento teorico del riduttore dopo il rodaggio  
Theoretical efficiency of the gearbox after the first running period

Motori applicabili

Motor adapters

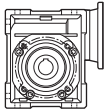
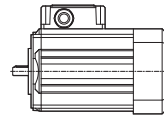

		SMT				SMM			
		5014 5024 5034 5044	5624 5634 5644 5654	6324 6334 6344	7124 7134 7144	5014 5024 5034	5624 5634 5644	6324 6334	7124 7134
CM	026	5 - 60				5 - 60			
	030	5 - 100		5-50		5 - 100		5-50	
	040	5 - 100			5-30	5 - 100			5-30

5 - 100

Rapporti di riduzione i  
Ratio i

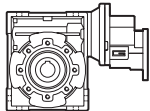

		SMT			SMM			
		5014 5024 5034 5044	5624 5634 5644 5654	6324 6334 6344	5014 5024 5034	5624 5634 5644	6324 6334	
CMP	056/030	60 - 150			60 - 150			
	056/040	60 - 300				60 - 300		
	063/040			60 - 120			60 - 120	

60 - 300

Rapporti di riduzione i  
Ratio i

## Dati tecnici

## Technical data





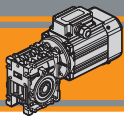

$P_1$ [kW]	$n_2$ [min <sup>-1</sup> ]	$M_2$ [Nm]	sf	i			$P_1$ [kW]	$n_2$ [min <sup>-1</sup> ]	$M_2$ [Nm]	sf	i		
<b>0.04</b>							<b>0.06</b>						
SMT5014	<b>280</b>	1.2	11.0	5	<b>CM026</b>		SMT5024	<b>280</b>	1.8	10.2	5	<b>CM030</b>	
SMM5014	<b>187</b>	1.7	8.1	7.5	<b>CM026</b>		SMM5024	<b>187</b>	2.6	7.7	7.5	<b>CM030</b>	
(1400 min <sup>-1</sup> )	<b>140</b>	2.3	6.2	10	<b>CM026</b>		(1400 min <sup>-1</sup> )	<b>140</b>	3.4	6.1	10	<b>CM030</b>	
	<b>93</b>	3.2	4.4	15	<b>CM026</b>			<b>93</b>	4.9	4.3	15	<b>CM030</b>	
	<b>70</b>	4.0	3.5	20	<b>CM026</b>			<b>70</b>	6.1	3.1	20	<b>CM030</b>	
	<b>47</b>	5.4	2.8	30	<b>CM026</b>			<b>56</b>	7.4	2.7	25	<b>CM030</b>	
	<b>35</b>	6.7	2.1	40	<b>CM026</b>			<b>47</b>	8.2	2.7	30	<b>CM030</b>	
	<b>28</b>	7.8	1.7	50	<b>CM026</b>			<b>35</b>	10	2.0	40	<b>CM030</b>	
	<b>23</b>	8.7	1.4	60	<b>CM026</b>			<b>28</b>	12	1.6	50	<b>CM030</b>	
								<b>23</b>	14	1.3	60	<b>CM030</b>	
	<b>280</b>	1.2	15.3	5	<b>CM030</b>			<b>23</b>	16	1.6	60		<b>CMP056/030</b>
	<b>187</b>	1.7	11.5	7.5	<b>CM030</b>			<b>19</b>	19	1.4	75		<b>CMP056/030</b>
	<b>140</b>	2.3	9.2	10	<b>CM030</b>			<b>18</b>	16	1.0	80	<b>CM030</b>	
	<b>93</b>	3.2	6.5	15	<b>CM030</b>			<b>16</b>	21	1.6	90		<b>CMP056/030</b>
	<b>70</b>	4.1	4.6	20	<b>CM030</b>			<b>14</b>	18	0.8	100	<b>CM030</b>	
	<b>56</b>	4.9	4.1	25	<b>CM030</b>			<b>12</b>	25	1.1	120		<b>CMP056/030</b>
	<b>47</b>	5.5	4.0	30	<b>CM030</b>			<b>9</b>	29	0.9	150		<b>CMP056/030</b>
	<b>35</b>	6.8	3.0	40	<b>CM030</b>								
	<b>28</b>	7.9	2.4	50	<b>CM030</b>			<b>35</b>	11	3.9	40	<b>CM040</b>	
	<b>23</b>	9.0	1.9	60	<b>CM030</b>			<b>28</b>	12	3.2	50	<b>CM040</b>	
	<b>23</b>	11	2.4	60		<b>CMP056/030</b>		<b>23</b>	14	2.5	60	<b>CM040</b>	
	<b>19</b>	12	2.1	75		<b>CMP056/030</b>		<b>23</b>	17	3.4	60		<b>CMP056/040</b>
	<b>18</b>	10	1.4	80	<b>CM030</b>			<b>19</b>	20	2.6	75		<b>CMP056/040</b>
	<b>16</b>	14	2.3	90		<b>CMP056/030</b>		<b>18</b>	17	1.9	80	<b>CM040</b>	
	<b>14</b>	12	1.2	100	<b>CM030</b>			<b>16</b>	23	3.1	90		<b>CMP056/040</b>
	<b>12</b>	17	1.7	120		<b>CMP056/030</b>		<b>14</b>	19	1.6	100	<b>CM040</b>	
	<b>9</b>	20	1.4	150		<b>CMP056/030</b>		<b>12</b>	28	2.2	120		<b>CMP056/040</b>
								<b>9</b>	32	1.8	150		<b>CMP056/040</b>
	<b>23</b>	9.5	3.8	60	<b>CM040</b>			<b>8</b>	35	1.5	180		<b>CMP056/040</b>
	<b>23</b>	11	5.2	60		<b>CMP056/040</b>		<b>6</b>	41	1.1	240		<b>CMP056/040</b>
	<b>19</b>	13	3.9	75		<b>CMP056/040</b>		<b>5</b>	46	0.9	300		<b>CMP056/040</b>
	<b>18</b>	11	2.9	80	<b>CM040</b>								
	<b>16</b>	15	4.7	90		<b>CMP056/040</b>							
	<b>14</b>	13	2.5	100	<b>CM040</b>								
	<b>12</b>	19	3.3	120		<b>CMP056/040</b>							
	<b>9</b>	21	2.7	150		<b>CMP056/040</b>							
	<b>8</b>	24	2.3	180		<b>CMP056/040</b>							
	<b>6</b>	28	1.7	240		<b>CMP056/040</b>							
	<b>5</b>	30	1.4	300		<b>CMP056/040</b>							
<b>0.06</b>							<b>0.09</b>						
SMT5024	<b>280</b>	1.8	7.3	5	<b>CM026</b>		SMT5034	<b>280</b>	2.7	4.9	5	<b>CM026</b>	
SMM5024	<b>187</b>	2.6	5.4	7.5	<b>CM026</b>		SMM5034	<b>187</b>	3.9	3.6	7.5	<b>CM026</b>	
(1400 min <sup>-1</sup> )	<b>140</b>	3.4	4.1	10	<b>CM026</b>		SMT5624	<b>140</b>	5.1	2.7	10	<b>CM026</b>	
	<b>93</b>	4.8	2.9	15	<b>CM026</b>		SMM5624	<b>93</b>	7.2	1.9	15	<b>CM026</b>	
	<b>70</b>	6.1	2.3	20	<b>CM026</b>		(1400 min <sup>-1</sup> )	<b>70</b>	9.1	1.5	20	<b>CM026</b>	
	<b>47</b>	8.1	1.9	30	<b>CM026</b>			<b>47</b>	12	1.2	30	<b>CM026</b>	
	<b>35</b>	10	1.4	40	<b>CM026</b>			<b>35</b>	15	0.9	40	<b>CM026</b>	
	<b>28</b>	12	1.1	50	<b>CM026</b>			<b>28</b>	17	0.7	50	<b>CM026</b>	
	<b>23</b>	13	0.9	60	<b>CM026</b>								

AC



Motori Motors	SMT		SMM	
		5014 5024 5034	5624	5014 5024 5034
IEC	56 B14		56 B14	

**CM  
CMP****Motoriduttori CA a vite senza fine  
AC Wormgearmotors****Dati tecnici****Technical data**

$P_1$ [kW]	$n_2$ [min <sup>-1</sup> ]	$M_2$ [Nm]	sf	i			$P_1$ [kW]	$n_2$ [min <sup>-1</sup> ]	$M_2$ [Nm]	sf	i		
<b>0.09</b>							<b>0.12</b>						
SMT5034	<b>280</b>	2.6	6.8	5	<b>CM030</b>		SMT5044	<b>93</b>	10	4.5	15	<b>CM040</b>	
SMM5034	<b>187</b>	3.9	5.1	7.5	<b>CM030</b>		SMT5634	<b>70</b>	13	3.1	20	<b>CM040</b>	
SMT5624	<b>140</b>	5.2	4.1	10	<b>CM030</b>		SMM5634	<b>56</b>	15	2.5	25	<b>CM040</b>	
SMM5624	<b>93</b>	7.3	2.9	15	<b>CM030</b>		(1400 min <sup>-1</sup> )	<b>47</b>	17	2.8	30	<b>CM040</b>	
(1400 min <sup>-1</sup> )	<b>70</b>	9.2	2.1	20	<b>CM030</b>			<b>35</b>	21	2.0	40	<b>CM040</b>	
	<b>56</b>	11	1.8	25	<b>CM030</b>			<b>28</b>	25	1.6	50	<b>CM040</b>	
	<b>47</b>	12	1.8	30	<b>CM030</b>			<b>23</b>	28	1.3	60	<b>CM040</b>	
	<b>35</b>	15	1.3	40	<b>CM030</b>			<b>23</b>	34	1.7	60	<b>CM040</b>	
	<b>28</b>	18	1.1	50	<b>CM030</b>			<b>19</b>	40	1.3	75	<b>CM040</b>	<b>CMP056/040</b>
	<b>23</b>	20	0.8	60	<b>CM030</b>			<b>18</b>	34	1.0	80	<b>CM040</b>	<b>CMP056/040</b>
	<b>23</b>	24	1.1	60		<b>CMP056/030</b>		<b>16</b>	45	1.6	90		<b>CMP056/040</b>
	<b>19</b>	29	0.9	75		<b>CMP056/030</b>		<b>14</b>	38	0.8	100	<b>CM040</b>	
	<b>16</b>	32	1.0	90		<b>CMP056/030</b>		<b>12</b>	56	1.1	120		<b>CMP056/040</b>
								<b>9</b>	64	1.0	150		<b>CMP056/040</b>
	<b>70</b>	10	4.2	20	<b>CM040</b>		<b>0.18</b>						
	<b>56</b>	11	3.3	25	<b>CM040</b>		SMT5644	<b>280</b>	5.3	2.4	5	<b>CM026</b>	
	<b>47</b>	13	3.7	30	<b>CM040</b>		SMM5644	<b>187</b>	7.7	1.8	7.5	<b>CM026</b>	
	<b>35</b>	16	2.6	40	<b>CM040</b>		(1400 min <sup>-1</sup> )	<b>140</b>	10	1.4	10	<b>CM026</b>	
	<b>28</b>	18	2.1	50	<b>CM040</b>			<b>93</b>	14	1.0	15	<b>CM026</b>	
	<b>23</b>	21	1.7	60	<b>CM040</b>			<b>70</b>	18	0.8	20	<b>CM026</b>	
	<b>23</b>	25	2.3	60		<b>CMP056/040</b>							
	<b>19</b>	30	1.7	75		<b>CMP056/040</b>		<b>280</b>	5.3	3.4	5	<b>CM030</b>	
	<b>18</b>	26	1.3	80	<b>CM040</b>			<b>187</b>	7.8	2.6	7.5	<b>CM030</b>	
	<b>16</b>	34	2.1	90		<b>CMP056/040</b>		<b>140</b>	10	2.0	10	<b>CM030</b>	
	<b>14</b>	28	1.1	100	<b>CM040</b>			<b>93</b>	15	1.4	15	<b>CM030</b>	
	<b>12</b>	42	1.5	120		<b>CMP056/040</b>		<b>70</b>	18	1.0	20	<b>CM030</b>	
	<b>9</b>	48	1.2	150		<b>CMP056/040</b>		<b>56</b>	22	0.9	25	<b>CM030</b>	
	<b>8</b>	53	1.0	180		<b>CMP056/040</b>		<b>47</b>	25	0.9	30	<b>CM030</b>	
<b>0.12</b>													
SMT5044	<b>280</b>	3.6	3.7	5	<b>CM026</b>			<b>280</b>	5.4	7.6	5	<b>CM040</b>	
SMT5634	<b>187</b>	5.2	2.7	7.5	<b>CM026</b>			<b>187</b>	7.9	5.6	7.5	<b>CM040</b>	
SMM5634	<b>140</b>	6.8	2.1	10	<b>CM026</b>			<b>140</b>	10	4.4	10	<b>CM040</b>	
(1400 min <sup>-1</sup> )	<b>93</b>	10	1.5	15	<b>CM026</b>			<b>93</b>	15	3.0	15	<b>CM040</b>	
	<b>70</b>	12	1.2	20	<b>CM026</b>			<b>70</b>	19	2.1	20	<b>CM040</b>	
	<b>47</b>	16	0.9	30	<b>CM026</b>			<b>56</b>	23	1.7	25	<b>CM040</b>	
	<b>35</b>	20	0.7	40	<b>CM026</b>			<b>47</b>	26	1.9	30	<b>CM040</b>	
	<b>280</b>	3.5	5.1	5	<b>CM030</b>			<b>35</b>	32	1.3	40	<b>CM040</b>	
	<b>187</b>	5.2	3.8	7.5	<b>CM030</b>			<b>28</b>	37	1.1	50	<b>CM040</b>	
	<b>140</b>	6.9	3.1	10	<b>CM030</b>			<b>23</b>	43	0.8	60	<b>CM040</b>	
	<b>93</b>	10	2.2	15	<b>CM030</b>			<b>23</b>	51	1.1	60		<b>CMP056/040</b>
	<b>70</b>	12	1.5	20	<b>CM030</b>			<b>19</b>	60	0.9	75		<b>CMP056/040</b>
	<b>56</b>	15	1.4	25	<b>CM030</b>			<b>18</b>	68	1.0	90		<b>CMP056/040</b>
	<b>47</b>	16	1.3	30	<b>CM030</b>								
	<b>35</b>	20	1.0	40	<b>CM030</b>			<b>280</b>	5.3	3.4	5	<b>CM030</b>	
	<b>28</b>	24	0.8	50	<b>CM030</b>			<b>187</b>	7.8	2.6	7.5	<b>CM030</b>	
	<b>23</b>	32	0.8	60		<b>CMP056/030</b>		<b>140</b>	10	2.0	10	<b>CM030</b>	
								<b>93</b>	15	1.4	15	<b>CM030</b>	
								<b>70</b>	18	1.0	20	<b>CM030</b>	
								<b>56</b>	22	0.9	25	<b>CM030</b>	
								<b>47</b>	25	0.9	30	<b>CM030</b>	



Motori Motors	SMT		SMM	
	5034 5044	5624 5634 5644	5034	5624 5634 5644
IEC	56 B14		56 B14	

## Dati tecnici

## Technical data

P <sub>1</sub> [kW]	n <sub>2</sub> [min <sup>-1</sup> ]	M <sub>2</sub> [Nm]	sf	i		
<b>0.18</b>						
SMT6324	<b>280</b>	5.4	7.6	5	<b>CM040</b>	CMP063/040 CMP063/040 CMP063/040
SMM6324	<b>187</b>	7.9	5.6	7.5	<b>CM040</b>	
(1400 min <sup>-1</sup> )	<b>140</b>	10	4.4	10	<b>CM040</b>	
	<b>93</b>	15	3.0	15	<b>CM040</b>	
	<b>70</b>	19	2.1	20	<b>CM040</b>	
	<b>56</b>	23	1.7	25	<b>CM040</b>	
	<b>47</b>	26	1.9	30	<b>CM040</b>	
	<b>35</b>	32	1.3	40	<b>CM040</b>	
	<b>28</b>	37	1.1	50	<b>CM040</b>	
	<b>23</b>	43	0.8	60	<b>CM040</b>	
	<b>23</b>	51	1.1	60		
	<b>19</b>	60	0.9	75		
	<b>18</b>	68	1.0	90		

P <sub>1</sub> [kW]	n <sub>2</sub> [min <sup>-1</sup> ]	M <sub>2</sub> [Nm]	sf	i		
<b>0.25</b>						
SMT6334	<b>280</b>	7.5	5.5	5	<b>CM040</b>	CMP063/040
SMM6334	<b>187</b>	11	4.0	7.5	<b>CM040</b>	
(1400 min <sup>-1</sup> )	<b>140</b>	14	3.1	10	<b>CM040</b>	
	<b>93</b>	21	2.2	15	<b>CM040</b>	
	<b>70</b>	27	1.5	20	<b>CM040</b>	
	<b>56</b>	32	1.2	25	<b>CM040</b>	
	<b>47</b>	36	1.3	30	<b>CM040</b>	
	<b>35</b>	44	0.9	40	<b>CM040</b>	
	<b>28</b>	51	0.8	50	<b>CM040</b>	
	<b>23</b>	70	0.8	60		

P <sub>1</sub> [kW]	n <sub>2</sub> [min <sup>-1</sup> ]	M <sub>2</sub> [Nm]	sf	i		
<b>0.25</b>						
SMT5654	<b>280</b>	7	1.8	5	<b>CM026</b>	CMP056/040
(1400 min <sup>-1</sup> )	<b>187</b>	11	1.3	8	<b>CM026</b>	
	<b>140</b>	14	1.0	10	<b>CM026</b>	
	<b>280</b>	7.3	2.5	5	<b>CM030</b>	
	<b>187</b>	11	1.8	7.5	<b>CM030</b>	
	<b>140</b>	14	1.5	10	<b>CM030</b>	
	<b>93</b>	20	1.0	15	<b>CM030</b>	
	<b>70</b>	26	0.7	20	<b>CM030</b>	
	<b>280</b>	7.5	5.5	5	<b>CM040</b>	
	<b>187</b>	11	4.0	7.5	<b>CM040</b>	
	<b>140</b>	14	3.1	10	<b>CM040</b>	
	<b>93</b>	21	2.2	15	<b>CM040</b>	
	<b>70</b>	27	1.5	20	<b>CM040</b>	
	<b>56</b>	32	1.2	25	<b>CM040</b>	
	<b>47</b>	36	1.3	30	<b>CM040</b>	
	<b>35</b>	44	0.9	40	<b>CM040</b>	
	<b>28</b>	51	0.8	50	<b>CM040</b>	
	<b>23</b>	70	0.8	60		

P <sub>1</sub> [kW]	n <sub>2</sub> [min <sup>-1</sup> ]	M <sub>2</sub> [Nm]	sf	i		
<b>0.37</b>						
SMT6344	<b>280</b>	11	1.7	5	<b>CM030</b>	
(1400 min <sup>-1</sup> )	<b>187</b>	16	1.2	7.5	<b>CM030</b>	
	<b>140</b>	21	1.0	10	<b>CM030</b>	
	<b>93</b>	30	0.7	15	<b>CM030</b>	
	<b>280</b>	11	3.7	5	<b>CM040</b>	
	<b>187</b>	16	2.7	7.5	<b>CM040</b>	
	<b>140</b>	21	2.1	10	<b>CM040</b>	
	<b>93</b>	31	1.5	15	<b>CM040</b>	
	<b>70</b>	39	1.0	20	<b>CM040</b>	
	<b>56</b>	47	0.8	25	<b>CM040</b>	
	<b>47</b>	53	0.9	30	<b>CM040</b>	

P <sub>1</sub> [kW]	n <sub>2</sub> [min <sup>-1</sup> ]	M <sub>2</sub> [Nm]	sf	i		
<b>0.25</b>						
SMT6334	<b>280</b>	7.3	2.5	5	<b>CM030</b>	
SMM6334	<b>187</b>	11	1.8	7.5	<b>CM030</b>	
(1400 min <sup>-1</sup> )	<b>140</b>	14	1.5	10	<b>CM030</b>	
	<b>93</b>	20	1.0	15	<b>CM030</b>	
	<b>70</b>	26	0.7	20	<b>CM030</b>	

P <sub>1</sub> [kW]	n <sub>2</sub> [min <sup>-1</sup> ]	M <sub>2</sub> [Nm]	sf	i		
<b>0.37</b>						
SMT7124	<b>280</b>	11	3.7	5	<b>CM040</b>	
SMM7124	<b>187</b>	16	2.7	7.5	<b>CM040</b>	
(1400 min <sup>-1</sup> )	<b>140</b>	21	2.1	10	<b>CM040</b>	
	<b>93</b>	31	1.5	15	<b>CM040</b>	
	<b>70</b>	39	1.0	20	<b>CM040</b>	
	<b>56</b>	47	0.8	25	<b>CM040</b>	
	<b>47</b>	53	0.9	30	<b>CM040</b>	

P <sub>1</sub> [kW]	n <sub>2</sub> [min <sup>-1</sup> ]	M <sub>2</sub> [Nm]	sf	i		
<b>0.55</b>						
SMT7134	<b>280</b>	17	2.5	5	<b>CM040</b>	
SMM7134	<b>187</b>	24	1.8	7.5	<b>CM040</b>	
(1400 min <sup>-1</sup> )	<b>140</b>	32	1.4	10	<b>CM040</b>	
	<b>93</b>	46	1.0	15	<b>CM040</b>	

P <sub>1</sub> [kW]	n <sub>2</sub> [min <sup>-1</sup> ]	M <sub>2</sub> [Nm]	sf	i		
<b>0.75</b>						
SMT7144	<b>280</b>	23	1.8	5	<b>CM040</b>	
(1400 min <sup>-1</sup> )	<b>187</b>	33	1.3	7.5	<b>CM040</b>	
	<b>140</b>	43	1.0	10	<b>CM040</b>	



Motori Motors	SMT			SMM	
	5654	6324 6334 6344	7124 7134 7144	6324 6334	7124 7134
IEC	56 B14	63 B14	71 B14	63 B14	71 B14

## Dati tecnici elettrici

## Electrical technical data



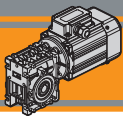

CM  
CMP

Dimensioni

Dimensions

CM 026 .. U

SMT50...TEFC  
SMM50... TEFC

SMT50...TENV  
SMM50... TENV

S3 servizio 30%  
duty

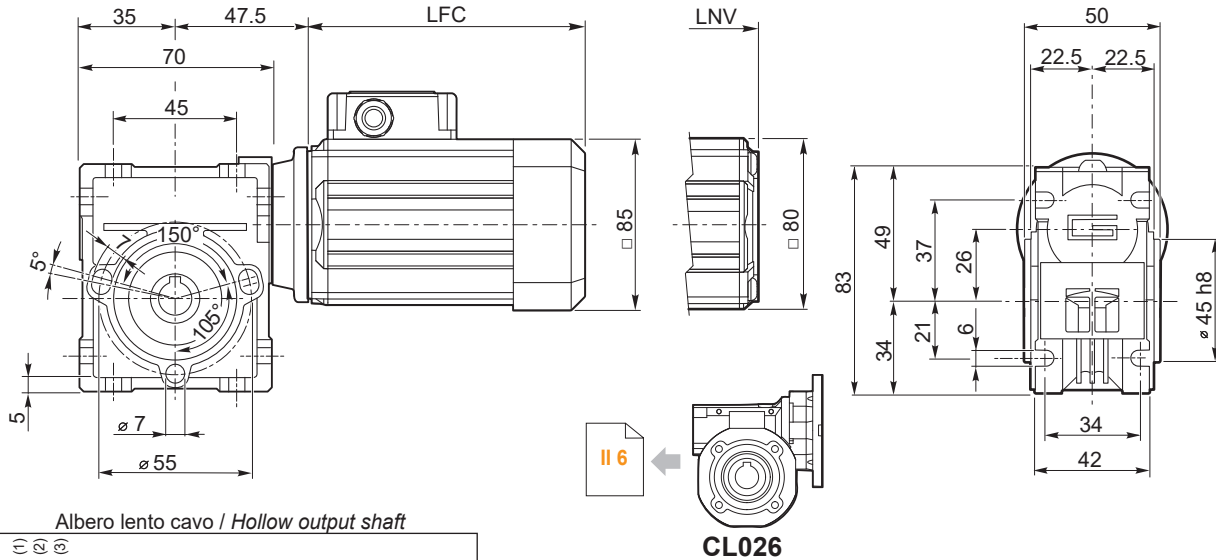

Albero lento cavo / Hollow output shaft

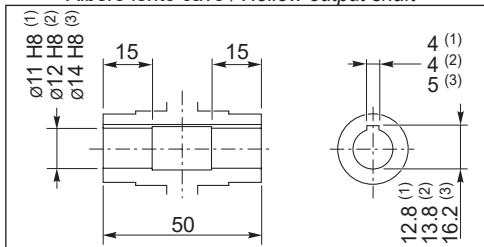

- (1): CM 120/026 (D11)
- (2): CM 120/026
- (3): CM 120/026 (D14)

SMT	LFC	LNV	Kg	
5014	135.5	108.5	3.1	
5024	150.5	123.5	3.5	
5034	175.5	148.5	4.3	
5044	200.5	173.5	5	

SMM	LFC	LNV	Kg	
5014	150.5	123.5	3.5	
5024	175.5	148.5	4.3	
5034	200.5	173.5	5	

Nota: il condensatore sarà fornito a corredo  
Note: the capacitor will be supplied separately

CM 026 .. U

SMT56...TEFC  
SMM56... TEFC

SMT56...TENV  
SMM56... TENV

S3 servizio 30%  
duty

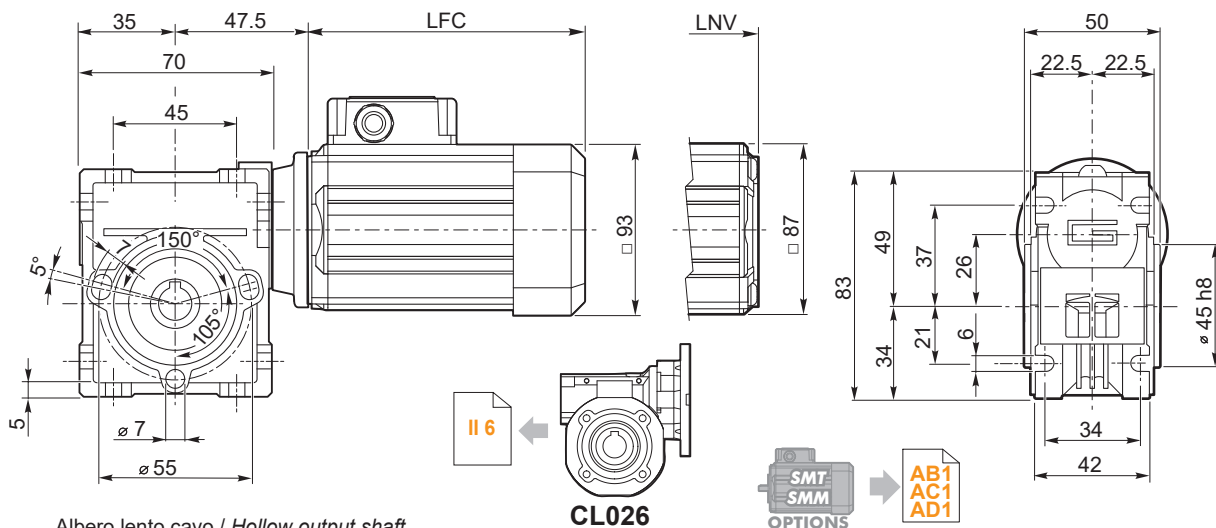

Albero lento cavo / Hollow output shaft

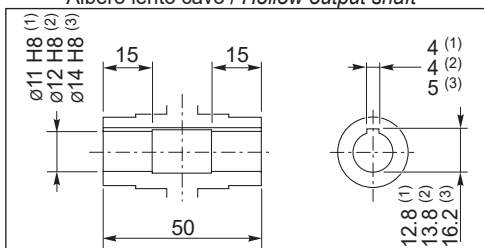

- (1): CM 120/026 (D11)
- (2): CM 120/026
- (3): CM 120/026 (D14)

SMT	LFC	LNV	Kg	
5624	141	117	3.6	
5634	151	127	4	
5644	186	162	5.2	
5654	206	182	5.9	

SMM	LFC	LNV	Kg	
5624	151	127	3.9	
5634	171	147	4.5	
5644	206	182	5.8	

Nota: il condensatore sarà fornito a corredo  
Note: the capacitor will be supplied separately

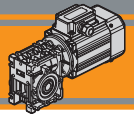

Dimensioni

Dimensions

CM 026 .. F

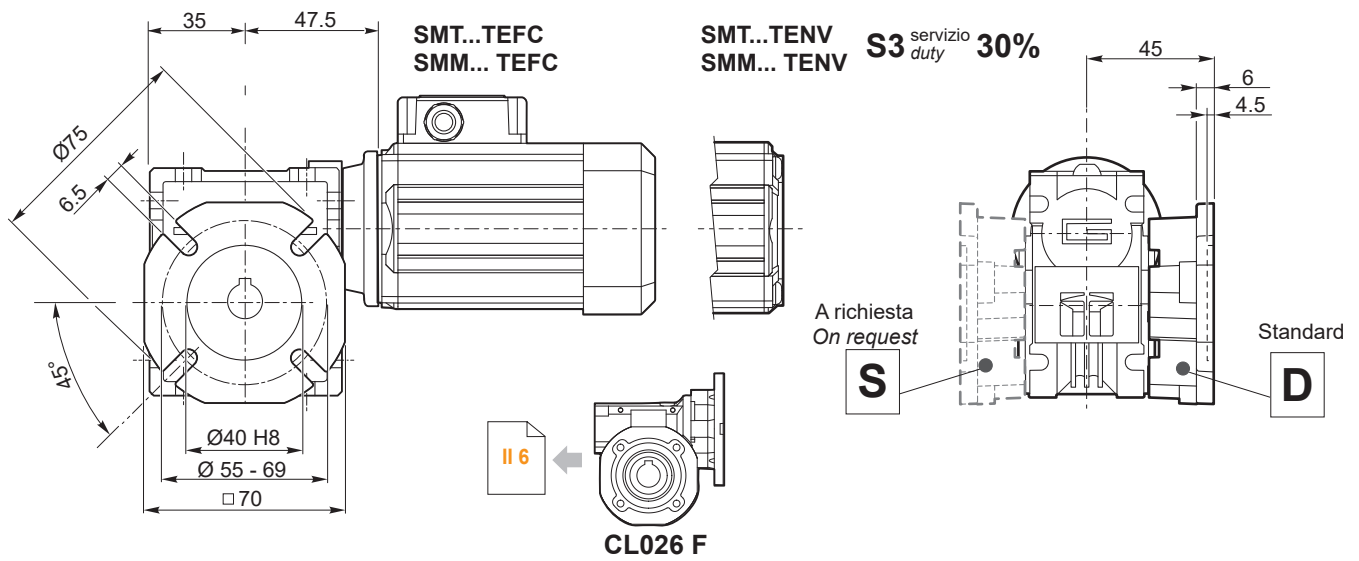

CM 026 .. F28

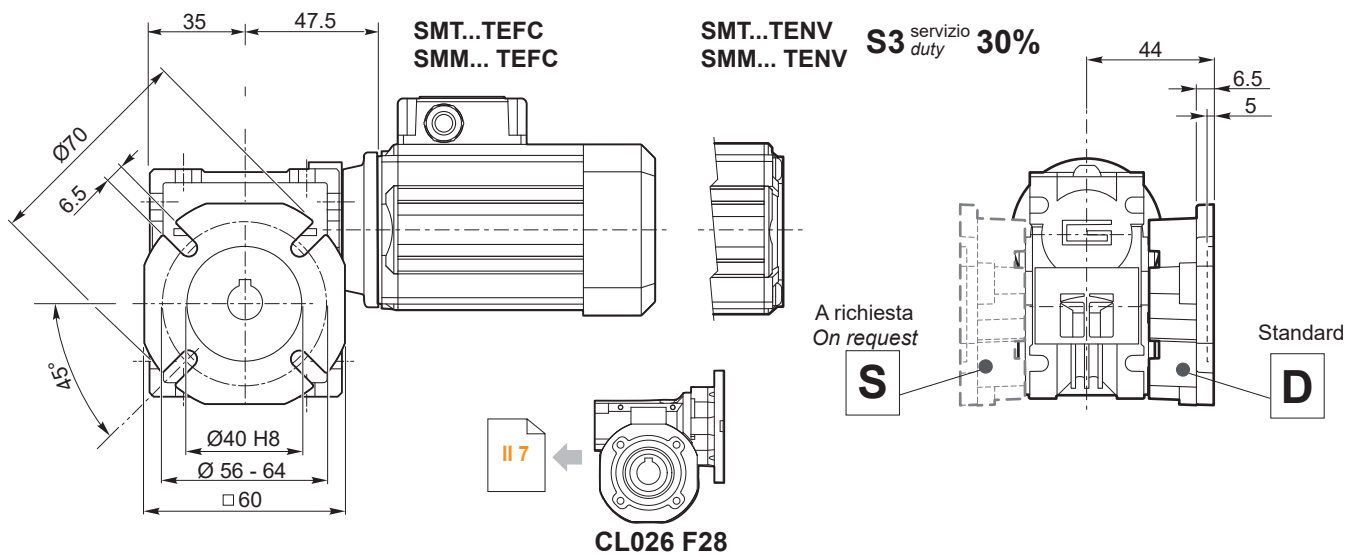

CM 026 .. F30

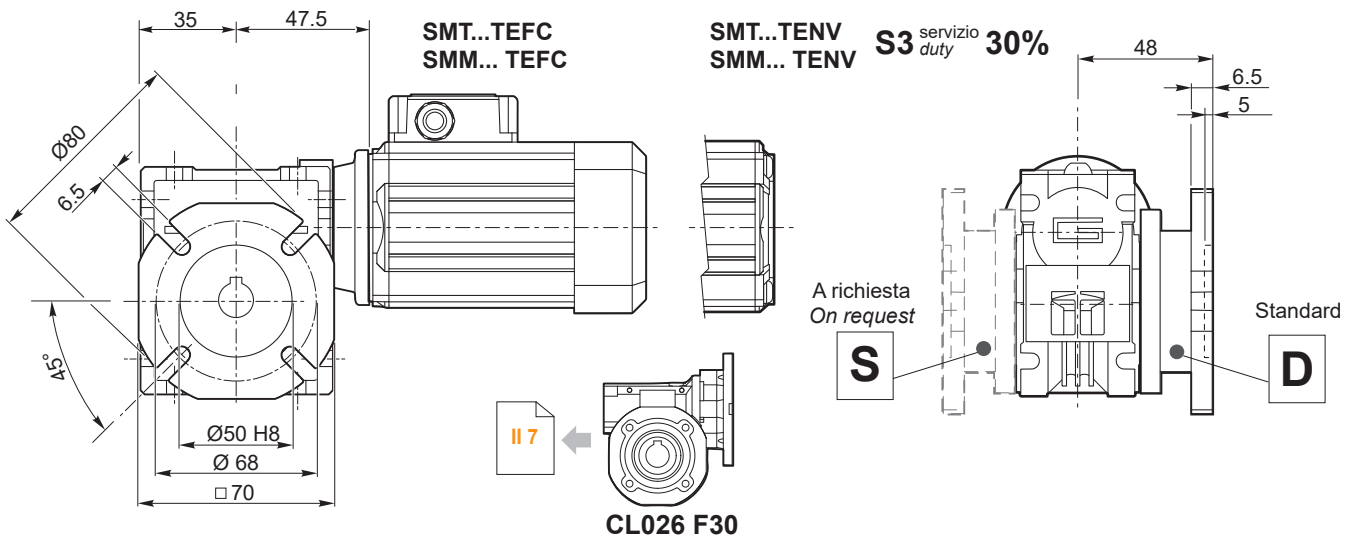

AC

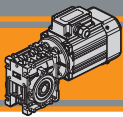

CM  
CMP

Dimensioni

Dimensions

CM 026 .. F30C

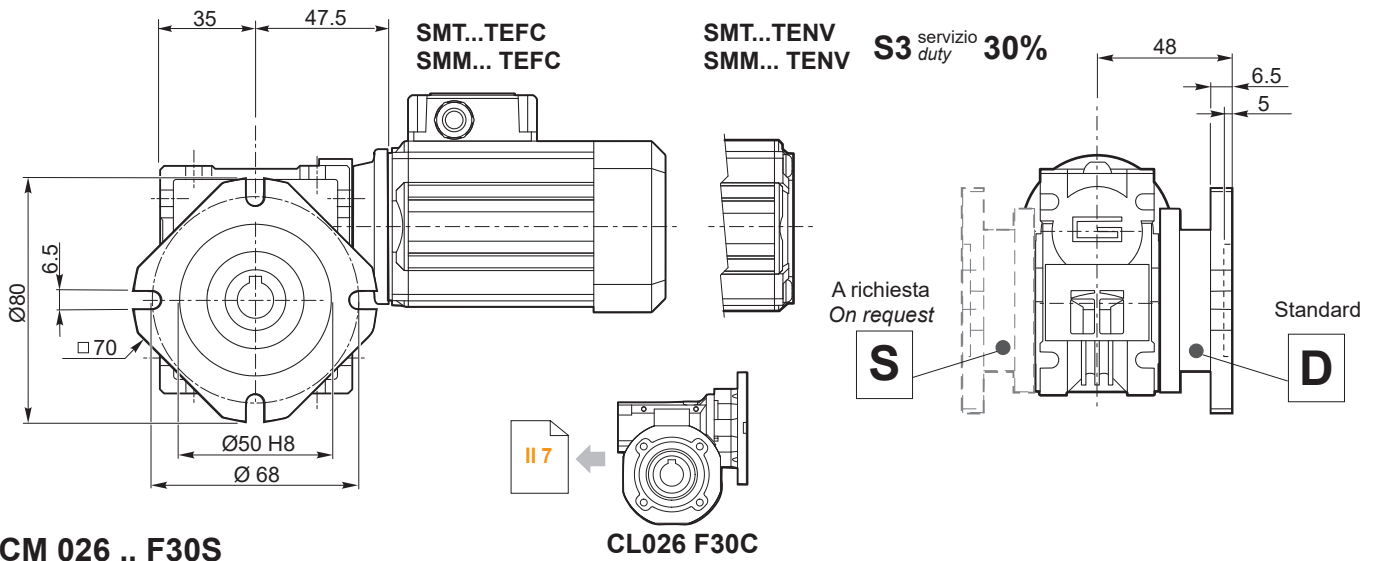

CM 026 .. F30S

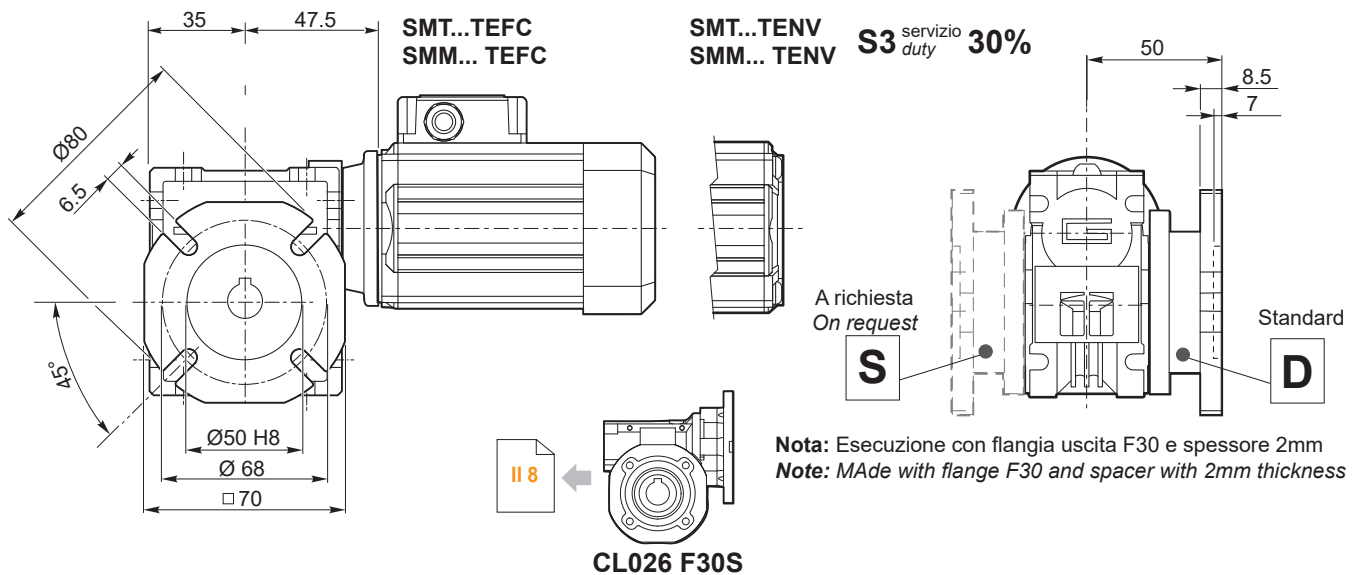

CM 026 .. F30SC

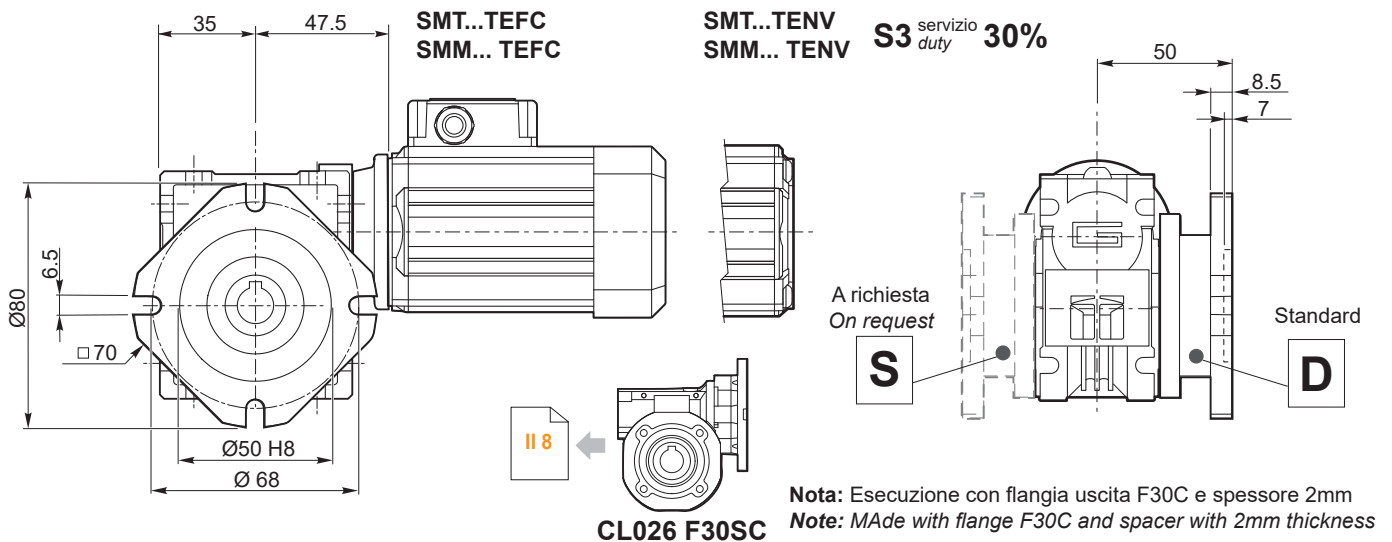

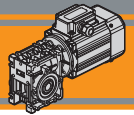

Dimensioni

Dimensions

CM 026 .. F100

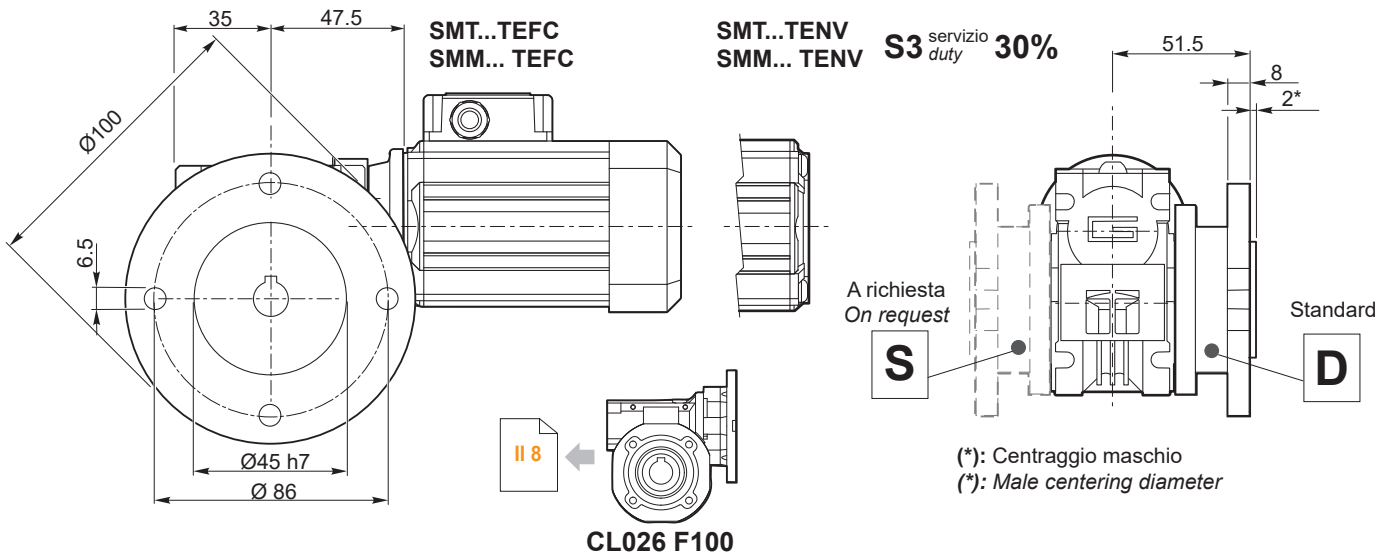

CM 030 ...U

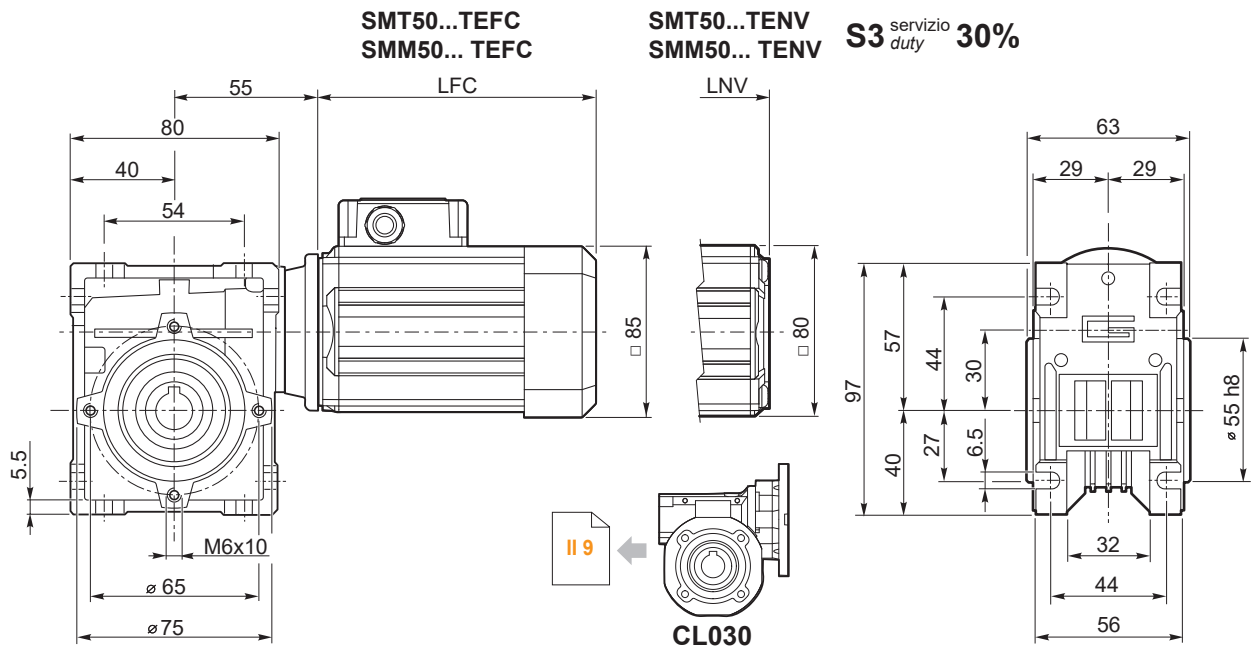

Albero lento cavo / Hollow output shaft

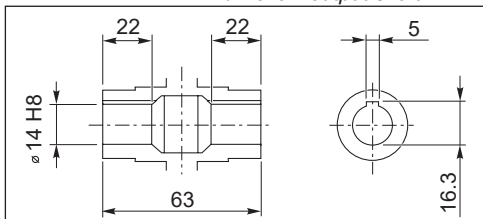

SMT	LFC	LNV	Kg	
5014	135.5	108.5	3.5	
5024	150.5	123.5	3.9	
5034	175.5	148.5	4.7	
5044	200.5	173.5	5.4	

SMM	LFC	LNV	Kg	
5014	150.5	123.5	3.9	
5024	175.5	148.5	4.7	
5034	200.5	173.5	5.4	

Nota: il condensatore sarà fornito a corredo  
Note: the capacitor will be supplied separately

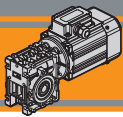

CM  
CMP

Dimensioni

Dimensions

CM 030 ...U

SMT56...TEFC  
SMM56... TEFC

SMT56...TENV  
SMM56... TENV

S3 servizio 30%  
duty

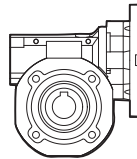
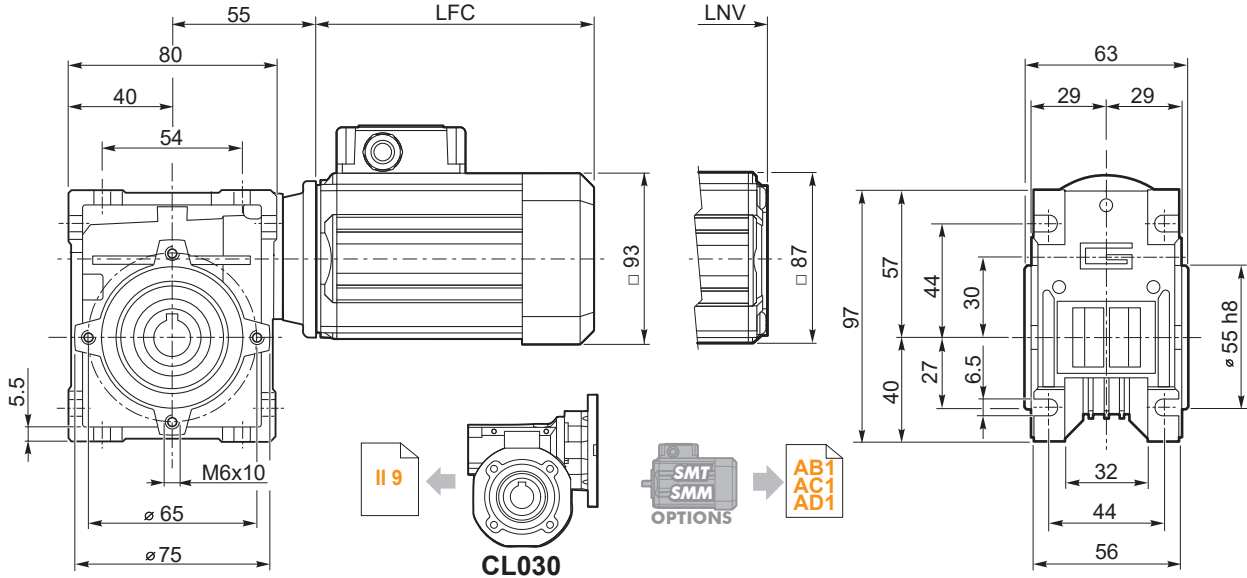

CL030

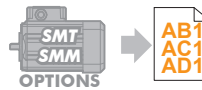

Albero lento cavo / Hollow output shaft

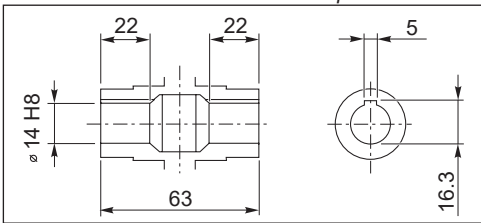

SMT	LFC	LNV	Kg	
5624	141	117	4	
5634	151	127	4.4	
5644	186	162	5.6	
5654	206	182	6.3	

SMM	LFC	LNV	Kg	
5624	151	127	4.3	
5634	171	147	4.9	
5644	206	182	6.2	

Nota: il condensatore sarà fornito a corredo  
Note: the capacitor will be supplied separately

CM 030 ...U

SMT63...TEFC  
SMM63... TEFC

SMT63...TENV  
SMM63... TENV

S3 servizio 30%  
duty

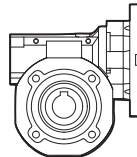
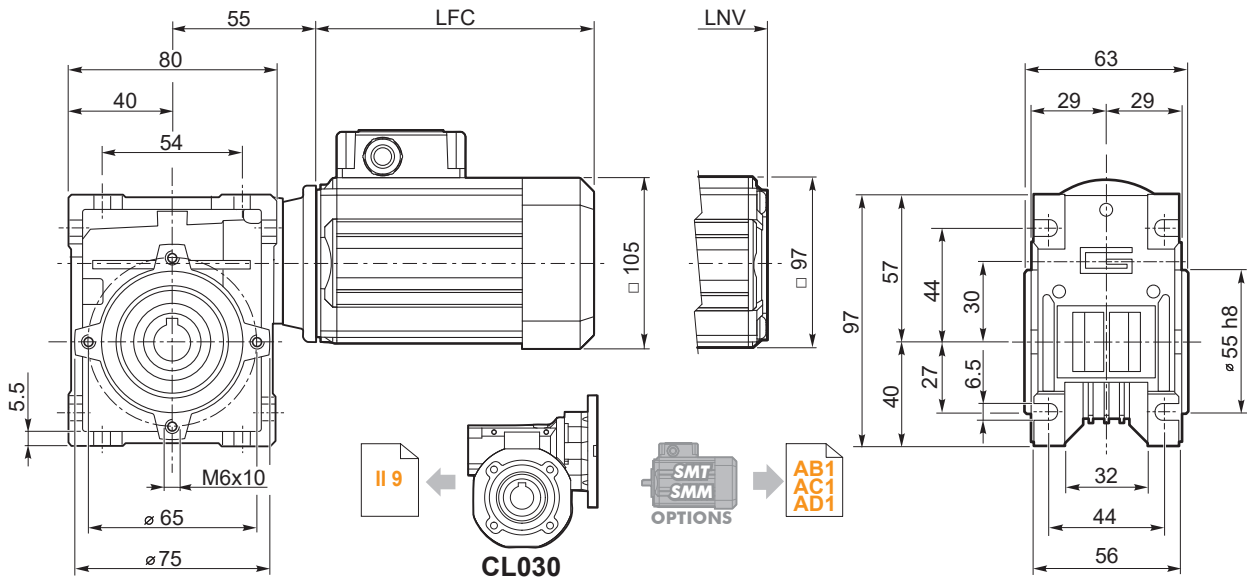

CL030



Albero lento cavo / Hollow output shaft

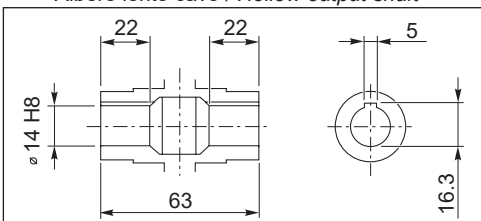

SMT	LFC	LNV	Kg	
6324	165.5	138.5	5.5	
6334	180.5	153.5	6.2	
6344	205.5	178.5	7.4	

SMM	LFC	LNV	Kg	
6324	180.5	153.5	6.3	
6334	205.5	178.5	7.5	

Nota: il condensatore sarà fornito a corredo  
Note: the capacitor will be supplied separately

Dimensioni

Dimensions

CMP 056/030 ...U

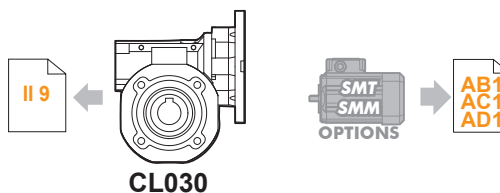
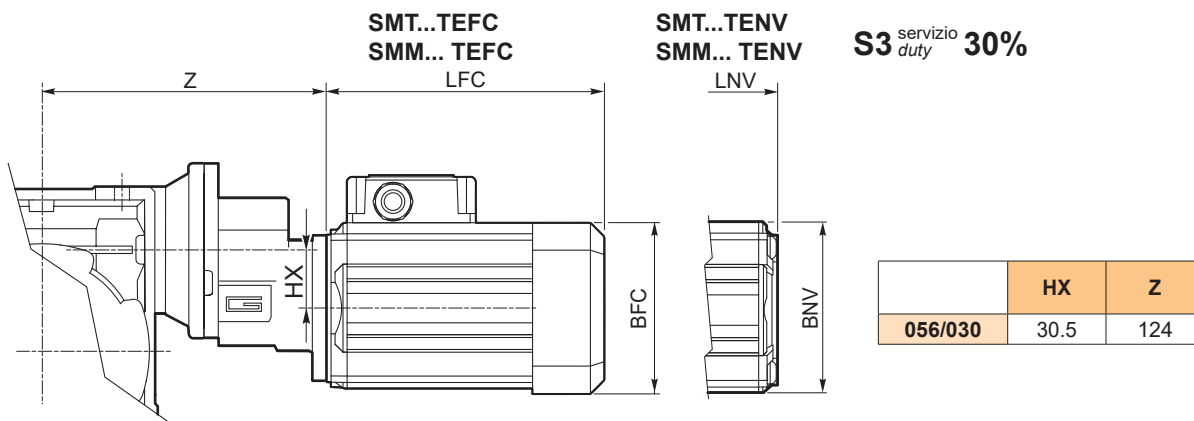

SMT	BFC	BNV	LFC	LNV
5014	□ 85	□ 80	135.5	108.5
5024			150.5	123.5
5034			175.5	148.5
5044			200.5	173.5
5624	□ 93	□ 87	141	117
5634			151	127
5644			186	162
5654			206	182

SMM	BFC	BNV	LFC	LNV
5014	□ 85	□ 80	150.5	123.5
5024			175.5	148.5
5034			200.5	173.5
5624			□ 93	□ 87
5634	186	162		
5644	206	182		

Nota: il condensatore sarà fornito a corredo  
Note: the capacitor will be supplied separately

CM 030 ... - F

CMP 056/030 ... - F

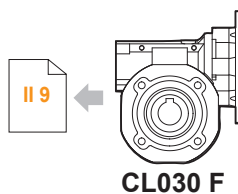
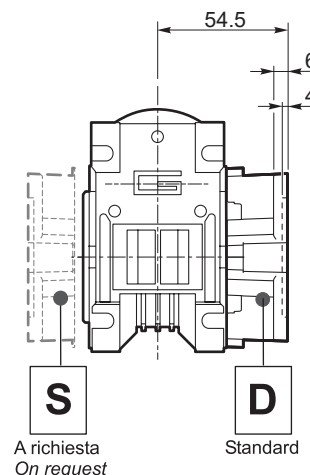
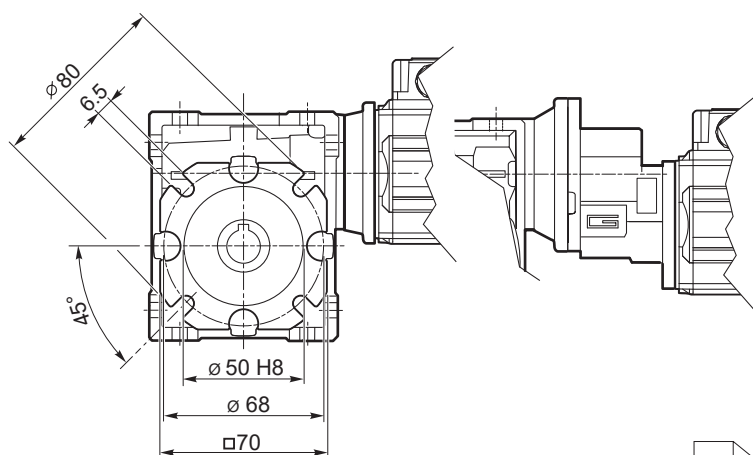

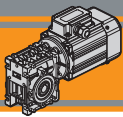

CM  
CMP

Motoriduttori CA a vite senza fine  
AC Wormgearmotors



Dimensioni

Dimensions

CM 040 ...U

SMT50...TEFC  
SMM50... TEFC

SMT50...TENV  
SMM50... TENV

S3 servizio 30%  
duty

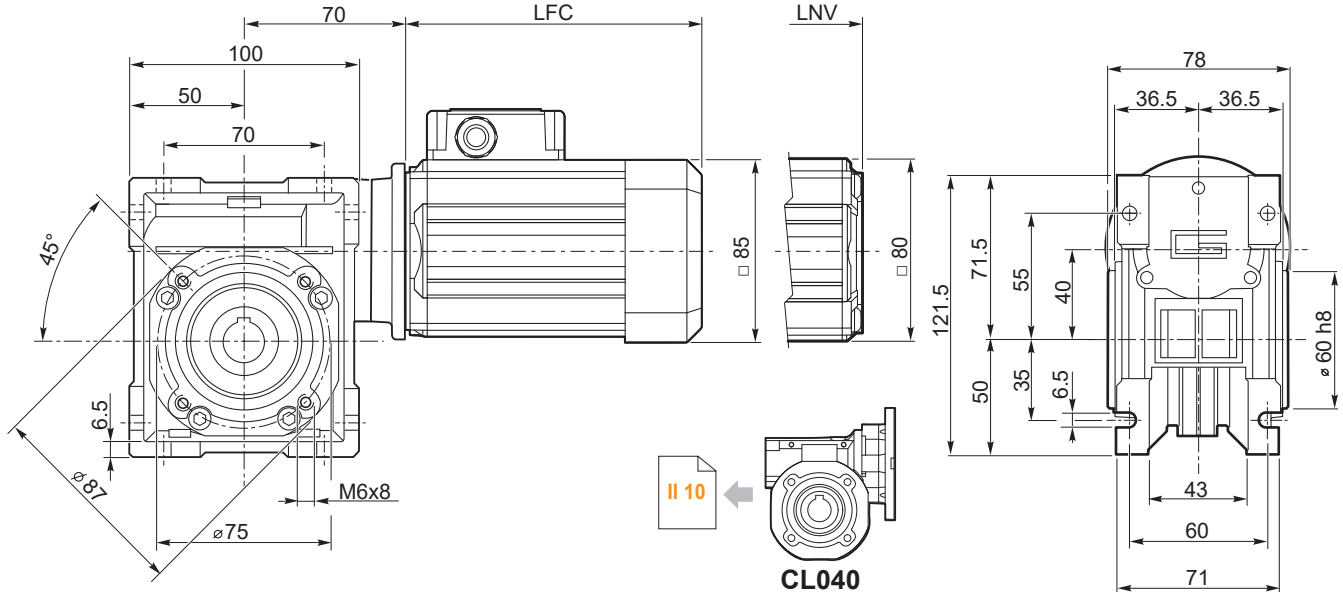

Albero lento cavo / Hollow output shaft

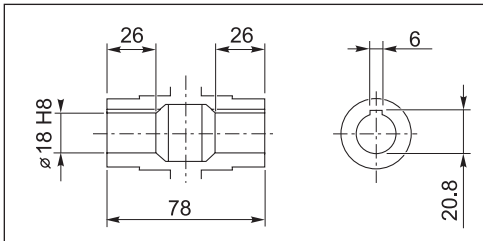

SMT	LFC	LNV	Kg	
5014	135.5	108.5	4.6	
5024	150.5	123.5	5	
5034	175.5	148.5	5.8	
5044	200.5	173.5	6.5	

SMM	LFC	LNV	Kg	
5014	150.5	123.5	5	
5024	175.5	148.5	5.8	
5034	200.5	173.5	6.5	

Nota: il condensatore sarà fornito a corredo  
Note: the capacitor will be supplied separately

CM 040 ...U

SMT56...TEFC  
SMM56... TEFC

SMT56...TENV  
SMM56... TENV

S3 servizio 30%  
duty

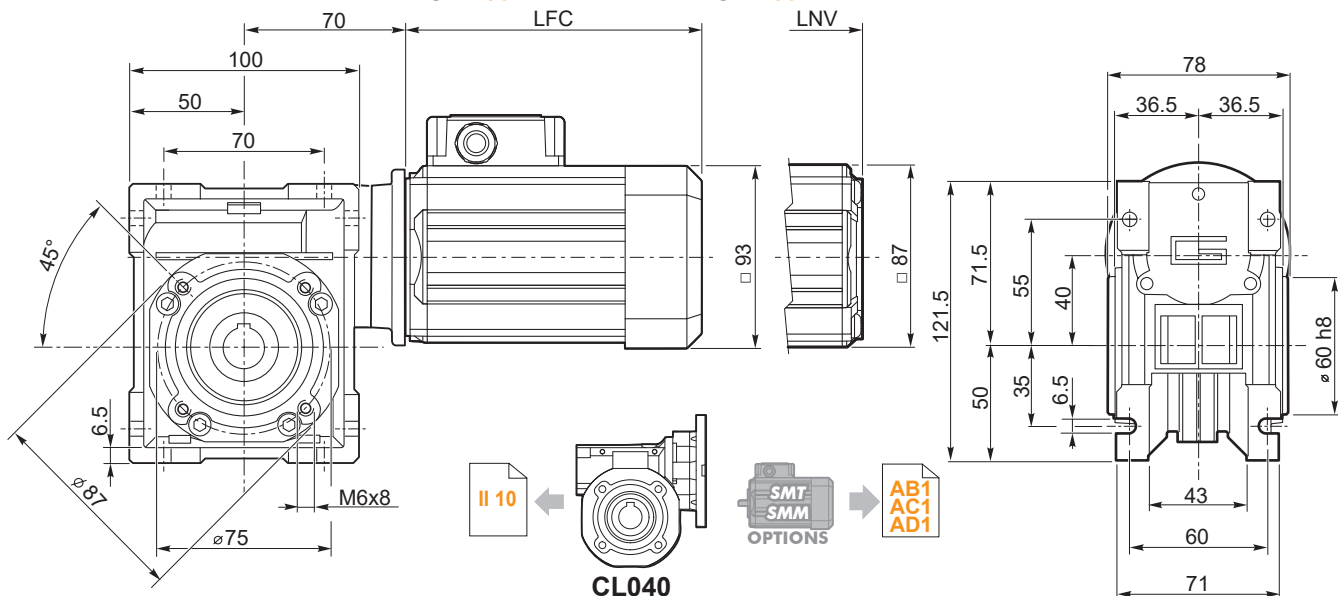

Albero lento cavo / Hollow output shaft

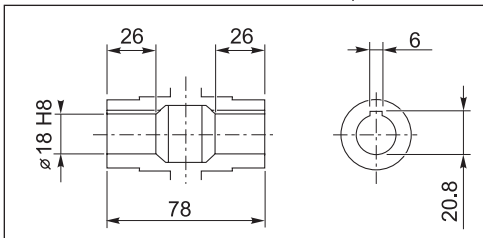

SMT	LFC	LNV	Kg	
5624	141	117	5.1	
5634	151	127	5.5	
5644	186	162	6.7	
5654	206	182	7.4	

SMM	LFC	LNV	Kg	
5624	151	127	5.4	
5634	171	147	6	
5644	206	182	7.3	

Nota: il condensatore sarà fornito a corredo  
Note: the capacitor will be supplied separately

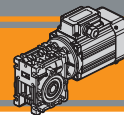

Dimensioni

Dimensions

CM 040 ...U

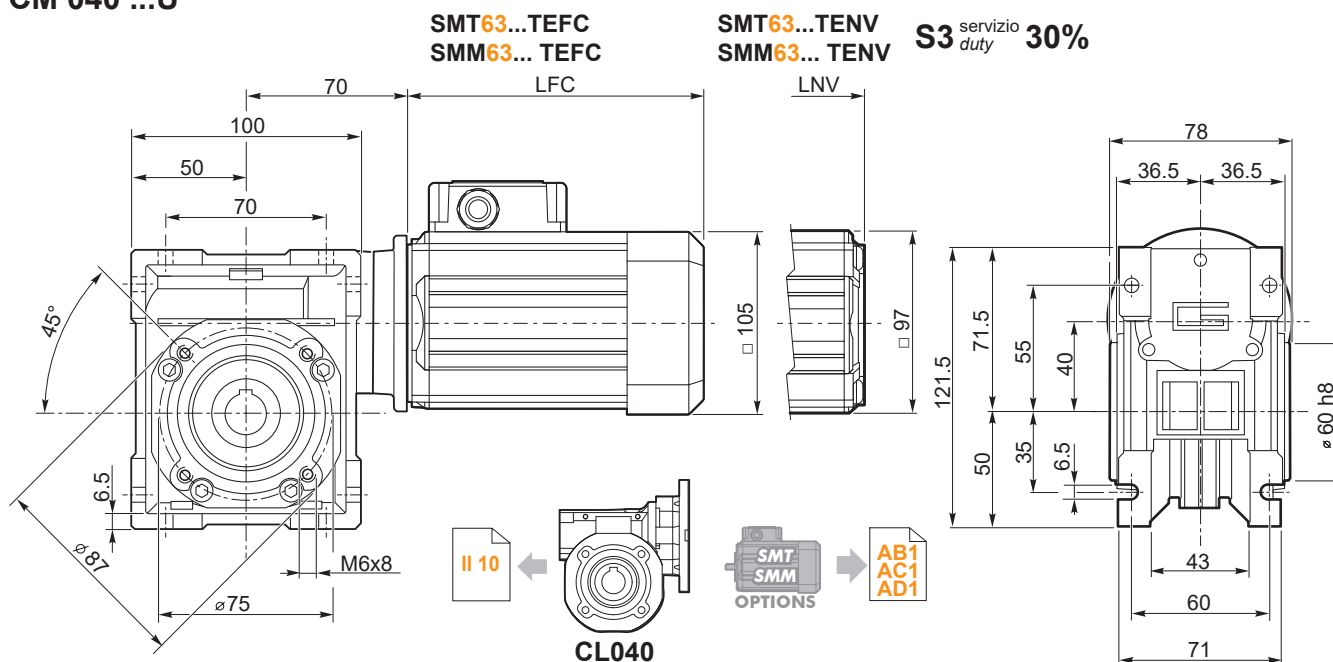

Albero lento cavo / Hollow output shaft

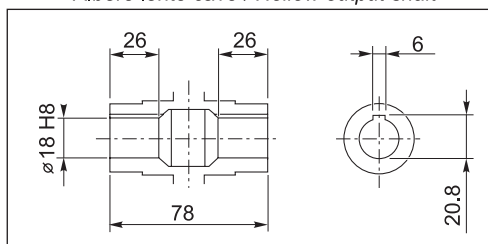

SMT	LFC	LNV	Kg	
6324	165.5	138.5	6.6	
6334	180.5	153.5	7.3	
6344	205.5	178.5	8.5	

SMM	LFC	LNV	Kg	
6324	180.5	153.5	7.4	
6334	205.5	178.5	8.6	

Nota: il condensatore sarà fornito a corredo  
Note: the capacitor will be supplied separately

CM 040 ...U

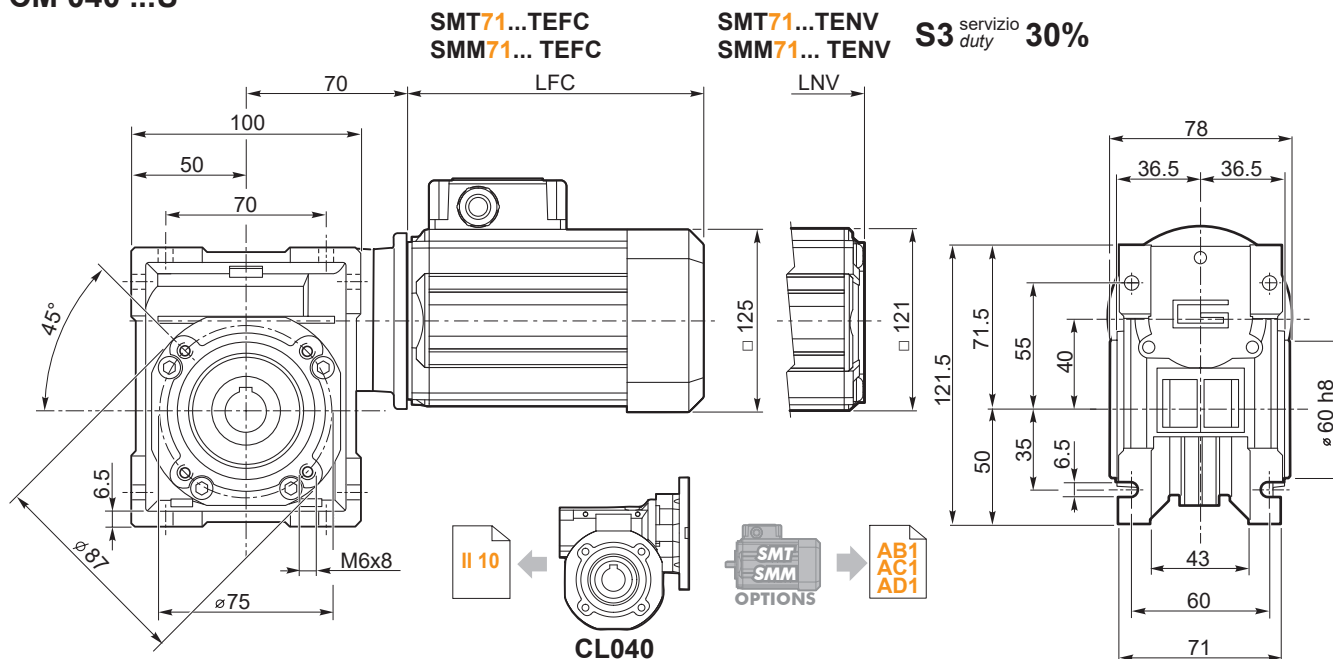

Albero lento cavo / Hollow output shaft

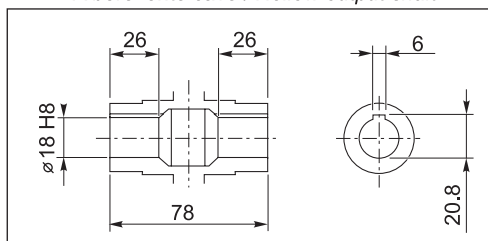

SMT	LFC	LNV	Kg	
7124	174	145.5	8.8	
7134	189	160.5	9.9	
7144	214	185.5	11.6	

SMM	LFC	LNV	Kg	
7124	189	160.5	9.5	
7134	214	185.5	11.5	

Nota: il condensatore sarà fornito a corredo  
Note: the capacitor will be supplied separately

AC

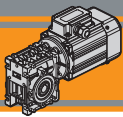

CM  
CMP

Dimensioni

Dimensions

CMP .../040 ...U

SMT...TEFC  
SMM... TEFC

SMT...TENV  
SMM... TENV

S3 servizio duty 30%

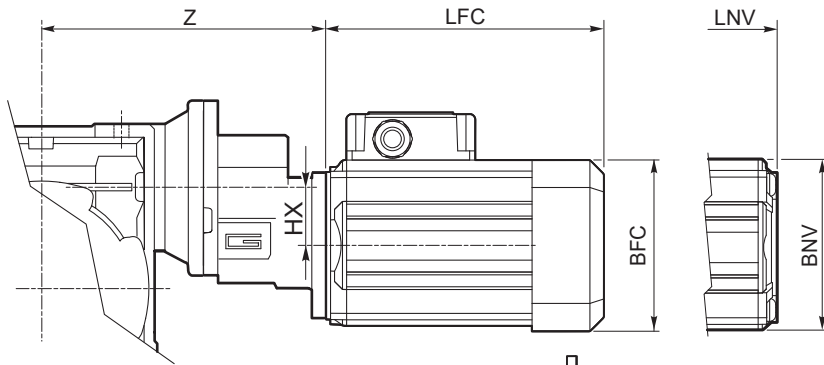

	HX	Z
056/040	30.5	139
063/040	30.5	142

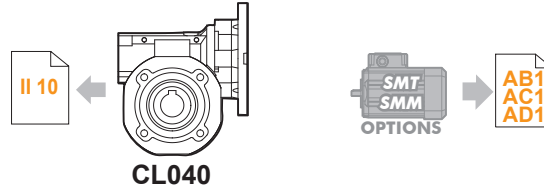

CL040

SMT	BFC	BNV	LFC	LNv
5014	□ 85	□ 80	135.5	108.5
5024			150.5	123.5
5034			175.5	148.5
5044			200.5	173.5
5624	□ 93	□ 87	141	117
5634			151	127
5644			186	162
5654			206	182
6324	□ 105	□ 97	165.5	138.5
6334			180.5	153.5
6344			205.5	178.5

SMM	BFC	BNV	LFC	LNv
5014	□ 85	□ 80	150.5	123.5
5024			175.5	148.5
5034			200.5	173.5
5624	□ 93	□ 87	151	127
5634			186	162
5644			206	182
6324	□ 105	□ 97	180.5	153.5
6334			205.5	178.5

Nota: il condensatore sarà fornito a corredo  
Note: the capacitor will be supplied separately

Dimensioni

Dimensions

CM 040 ... - F

CMP .../040 ... - F

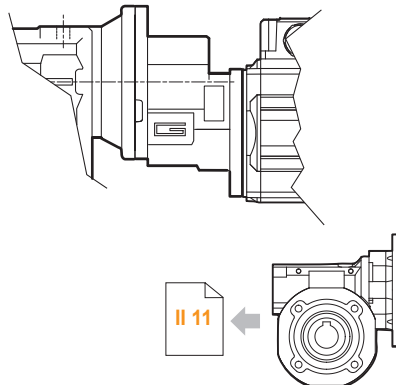
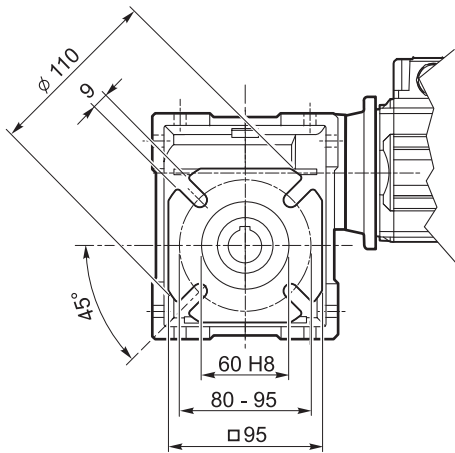

CL040 F

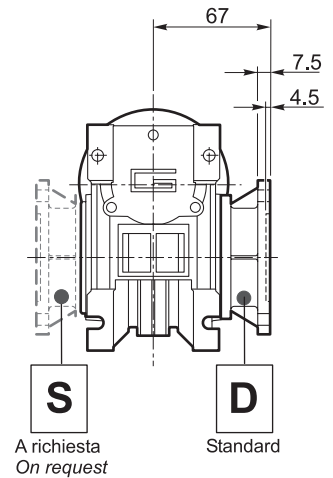

CM 040 ... - FB

CMP .../040 ... - FB

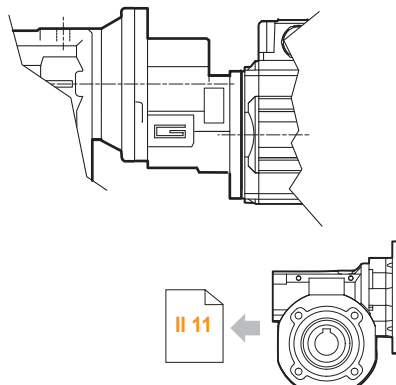
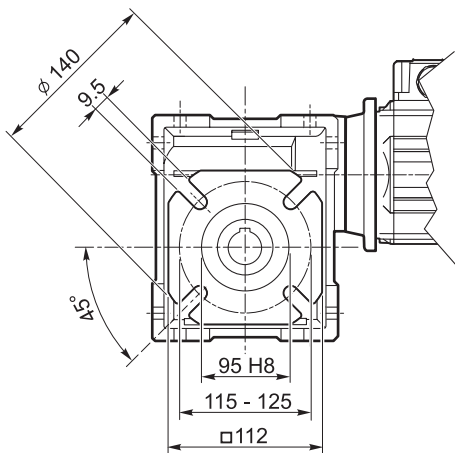

CL040 FB

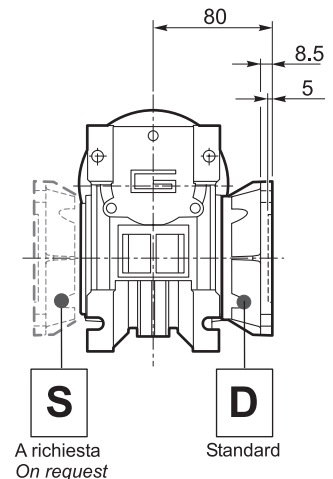

CM 040 ... - FL

CMP .../040 ... - FL

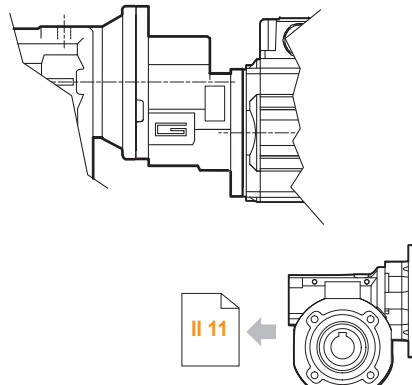
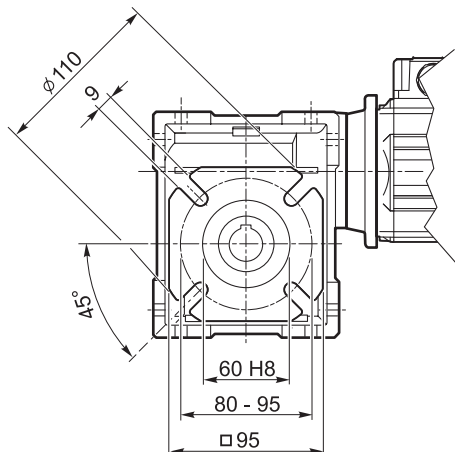

CL040 FL

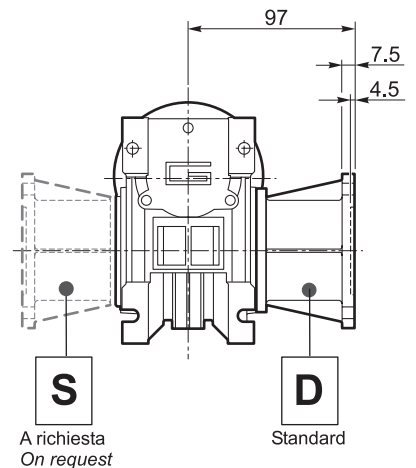

AC

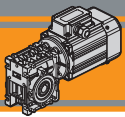

CM  
CMP

Opzioni

Options

**VS** - Vite sporgente / *Extended input shaft*

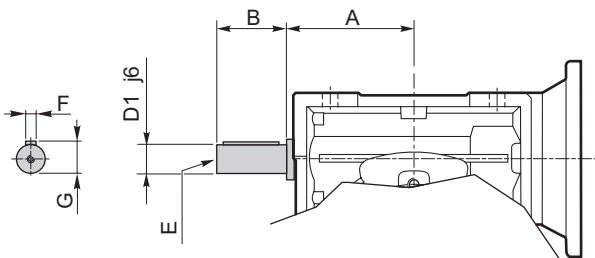

CM	CMP	A	B	D <sub>1</sub> j6	E	F	G
030	056/030	45	20	9	M4	3	10.2
040	056/040 063/040	53	23	11	M5	4	12.5

 Costruito su richiesta  
*Built on request*

Accessori

Accessories

**SC** - Safety cover

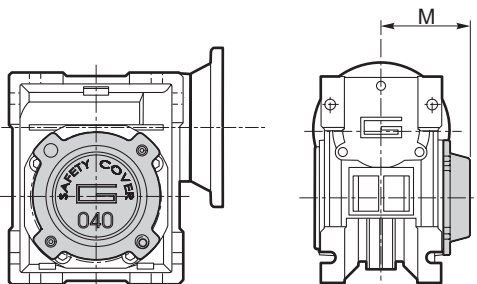

CM	CMP	M
030	056/030	47
040	056/040 063/040	54.5

**WD** - Kit washdown cover

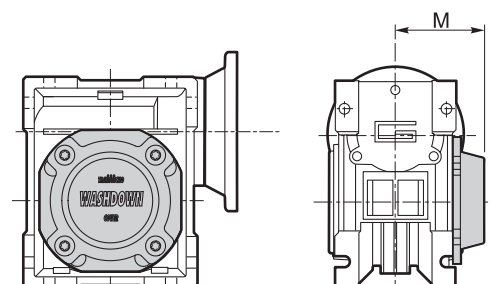

CM	CMP	M
030	056/030	48
040	056/040 063/040	55.5

Accessori

Accessories

Albero lento

Output shaft

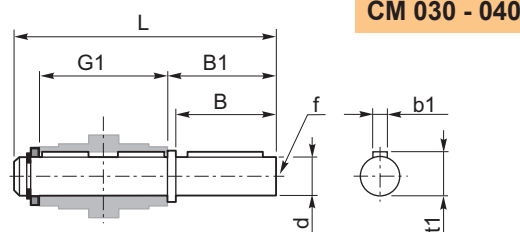
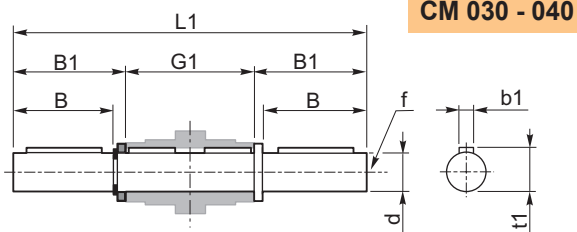

CM	CMP	d <sub>h7</sub>	B	B1	G1	L	L1	f	b1	t1
030	056/030	14	30	32.5	63	102	128	M6	5	16
040	056/040 063/040	18	40	43	78	128	164	M6	6	20.5

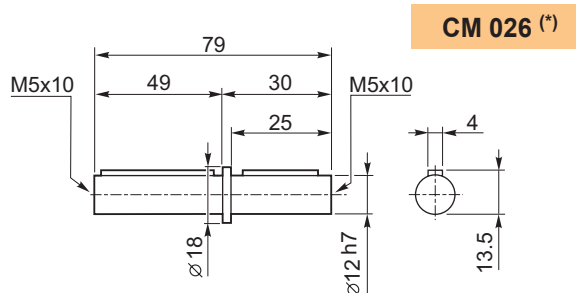

(\*)  
Nota: disponibile solo per cavo uscita Ø12  
Note: available for output hollow shaft Ø12 only

Braccio di reazione

Torque arm

CM	CMP	K1	G	KG	KH	R
030	056/030	85	14	23	8	15
040	056/040 063/040	100	14	31	10	18

DZ

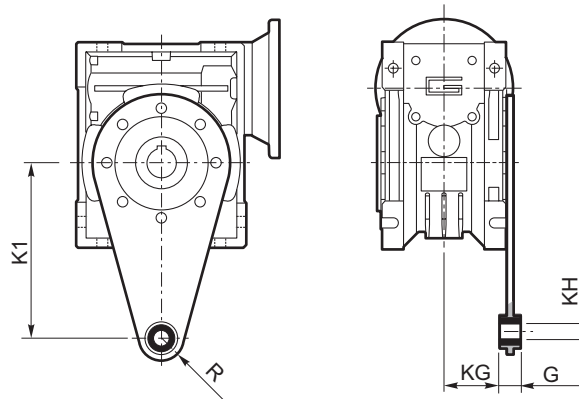



**MINI**  **TECNO**™  
**small** but strong

**CMM**

Motoriduttori CA combinati a vite senza fine  
AC Double reduction wormgearmotors



**MINI**  **TECNO**™ brand of  
**TRANSTECNO**®





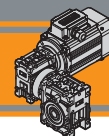

<b>Indice</b>	<b>Index</b>	Pag. Page
Caratteristiche tecniche	<i>Technical features</i>	<b>A12</b>
Designazione	<i>Classification</i>	<b>A13</b>
Simbologia	<i>Symbols</i>	<b>A14</b>
Esecuzioni di montaggio	<i>Mounting executions</i>	<b>A14</b>
Combinazioni rapporti	<i>Combination ratio</i>	<b>A14</b>
Lubrificazione	<i>Lubrication</i>	<b>A14</b>
Dati tecnici	<i>Technical data</i>	<b>A15</b>
Motori applicabili	<i>Motor adapters</i>	<b>A17</b>
Dimensioni	<i>Dimensions</i>	<b>A18</b>
Opzioni	<i>Options</i>	<b>A112</b>
Accessori	<i>Accessories</i>	<b>A112</b>

Questa sezione annulla e sostituisce ogni precedente edizione o revisione. Qualora questa sezione non Vi sia giunta in distribuzione controllata, l'aggiornamento dei dati ivi contenuto non è assicurato. **In tal caso la versione più aggiornata è disponibile sul nostro sito internet [www.transtecno.com](http://www.transtecno.com)**

*This section replaces any previous edition and revision. If you obtained this catalogue other than through controlled distribution channels, the most up to date content is not guaranteed. In this case the latest version is available on our web site [www.transtecno.com](http://www.transtecno.com)*

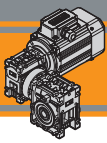
**Caratteristiche tecniche****Technical features**

Le caratteristiche principali dei motoriduttori CMM sono:

- Costruzione compatta
- Motorizzazioni in corrente alternata monofase e trifase
- Carcassa motore estrusa in alluminio anodizzato nero
- Carcasse dei riduttori in pressofusione di alluminio
- Motore elettrico AC con grado di protezione IP66
- Lubrificazione permanente con olio sintetico
- Disponibili sia nella versione ventilata TEFC (servizio S1) che non ventilata TENV (servizio S3)
- Protezione termica PTO 150°C per le taglie motore 56 e 63.
- SMT56 e SMT63 adatti al funzionamento con alimentazione da inverter
- Disponibili nelle versioni autofrenante, servoventilata e con certificazione UL.

*CMM gearmotors range has the following main features:*

- *Compact design*
- *AC single phase and three phase motors available*
- *Motor extruded aluminum housing black anodized*
- *Gearbox die-cast aluminum housing*
- *AC electric motor in IP66 protection Standard*
- *Permanent synthetic oil long-life lubrication*
- *Fan cooled TEFC (duty S1) and not ventilated TENV (duty S3) versions available*
- *PTO 150°C thermal protection for motor sizes 56 and 63.*
- *SMT56 and SMT63 are suitable for inverter duty*
- *Brake motors, forced ventilation motors and UL compliance versions available.*

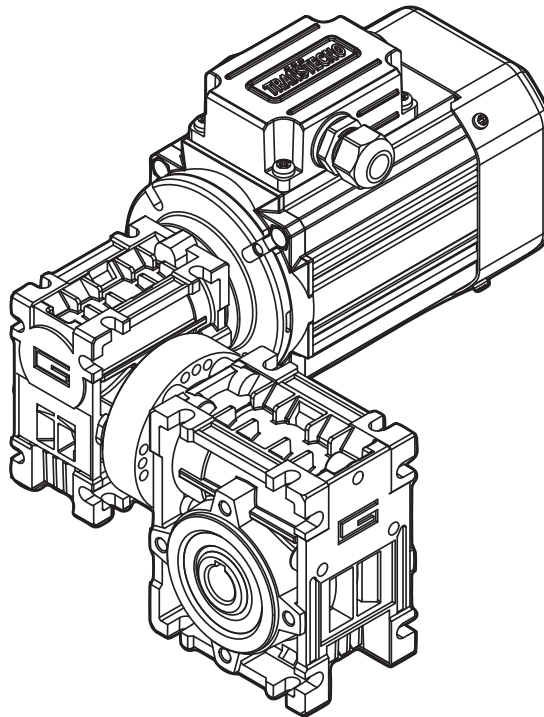

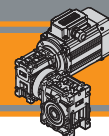

Designazione

Classification

RIDUTTORE / GEARBOX										
CMM	030/040	FD	150	63	B5	SZDX	BRSX	90	US1	VS
Tipo Type	Grandezza Size	Versione Version	Rapporto Ratio	IEC 	Forma costruttiva Version	Albero di uscita Output shaft	Braccio di reazione Torque arm	Angolo Angle	Esecuzione di montaggio Mounting execution	Opzioni Options
	026/026 026/026 (D11) 026/026 (D14) 026/030 026/040  030/040	U F...	vedi tabelle see tables	56.. 63..	B5 B14	SZDX SZSX DZ	BRDX BRSX  *	0° 90° 180° 270°	UB1 UB2 US1 US2 UV1 UV2 UC1 UC2	VS1 VS2

NOTA: il braccio di reazione viene fornito smontato.

\* NOTE: the torque arm will be supplied not assembled.

Versione Riduttore  
Gearbox Version

U F...D F...S

Albero di uscita  
Output shaft

SZDX SZSX DZ

Braccio di reazione  
Torque arm \*

BRDX BRSX

Angolo  
Angle

90° 90°  
180° 0°  
270° 270°

MOTORE TRIFASE / THREE PHASE MOTOR										
SMT	63	2	4	0.18 kW	B14	230-400 V	50 Hz	TEFC	BR	T1
Tipo Type	Grandezza Size	Indicativo potenza Power coefficient	Poli Poles	Potenza Power	Forma costruttiva Version	Tensione Voltage	Frequenza Frequency	Ventilazione Fan cooling	Opzioni Options	Pos. Morsettiera Terminal box pos.
	Vedere tab. See tab.	1-2-3-4	4	0.04 kW ... 0.25 kW	B14	230-400 V  460V	50Hz  60Hz	TEFC  TENV		T1 (Std) 

MOTORE MONOFASE / SINGLE PHASE MOTOR										
SMM	63	2	4	0.18 kW	B14	230 V	50 Hz	TEFC	UL-CSA	T1
Tipo Type	Grandezza Size	Indicativo potenza Power coefficient	Poli Poles	Potenza Power	Forma costruttiva Version	Tensione Voltage	Frequenza Frequency	Ventilazione Fan cooling	Opzioni Options	Pos. Morsettiera Terminal box pos.
	Vedere tab. See tab.	1-2-3-4	4	0.04 kW ... 0.25 kW	B14	230V	50Hz	TEFC  TENV		T1 (Std) 

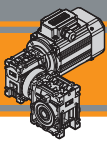

**Simbologia**

**Symbols**

$n_1$ [min <sup>-1</sup> ]	Velocità in ingresso / <i>Input speed</i>	$M_2$ [Nm]	Coppia in uscita in funzione di $P_1$ / <i>Output torque referred to <math>P_1</math></i>
$n_2$ [min <sup>-1</sup> ]	Velocità in uscita / <i>Output speed</i>	sf	Fattore di servizio / <i>Service factor</i>
$i$	Rapporto di riduzione / <i>Ratio</i>	$R_2$ [N]	Carico radiale ammissibile in uscita / <i>Permitted output radial load</i>
$P_1$ [kW]	Potenza in entrata / <i>Input power</i>	$A_2$ [N]	Carico assiale ammissibile in uscita / <i>Permitted output axial load</i>

**Esecuzioni di montaggio**

**Mounting executions**

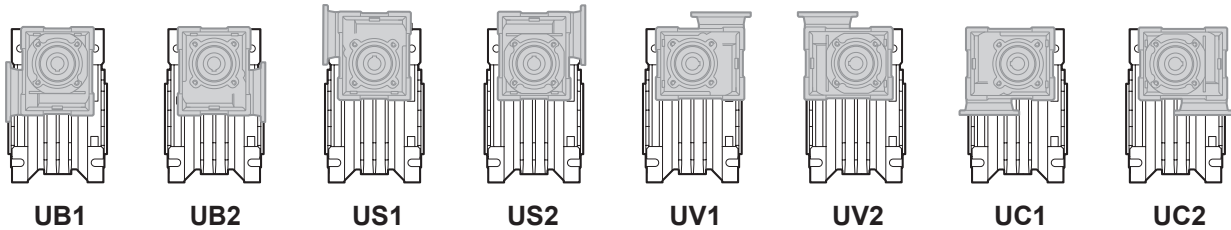

**Combinazioni rapporti**

**Combination ratio**

CMM 026/026 - CMM 026/030 - CMM 026/040												
$i (i_1 \times i_2)$												
	150	225	300	450	600	900	1200	1500	1800	2400	3000	3600
$i_1$	10	15	10	15	20	30	40	50	60	60	60	60
$i_2$	15	15	30	30	30	30	30	30	30	40	50	60

CMM 030/040														
$i (i_1 \times i_2)$														
	150	200	250	300	400	500	600	750	900	1200	1500	1800	2400	3000
$i_1$	10	10	10	10	10	10	20	25	30	40	50	60	60	60
$i_2$	15	20	25	30	40	50	30	30	30	30	30	30	40	50

**Lubrificazione**

**Lubrication**

Tutti i motoriduttori nelle taglie 26, 30, 40 sono forniti completi di lubrificante sintetico viscosità 320, pertanto possono essere installati in qualunque posizione di montaggio e non necessitano di manutenzione.

*Permanent synthetic oil long-life lubrication (viscosity grade 320) makes it possible to use the gearmotors size 26, 30, 40 in all mounting positions; for this reason they can be installed in any assembly position and do not require maintenance.*

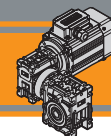

Dati tecnici

Technical data

P <sub>1</sub> [kW]	n <sub>2</sub> [min <sup>-1</sup> ]	M <sub>2</sub> [Nm]	sf	i		P <sub>1</sub> [kW]	n <sub>2</sub> [min <sup>-1</sup> ]	M <sub>2</sub> [Nm]	sf	i				
<b>0.04</b>						<b>0.06</b>								
SMT5014	9.3	23	1.1	150	<b>CMM 026/026</b>	SMT5024	9.3	33	0.8	150	<b>CMM 026/026</b>			
SMM5014	6.2	32	0.8	225		SMM5024	6.2	33	0.8	225				
(1400 min <sup>-1</sup> )	4.7	34	0.8	300			9.3	34	1.1	150	<b>CMM 026/030</b>			
	3.1	34	0.8	450			6.2	48	0.8	225				
	2.3	34	0.8	600			4.7	50	0.8	300				
	1.6	34	0.8	900			9.3	35	2.5	150	<b>CMM 026/040</b>			
	1.2	34	0.8	1200			6.2	50	1.8	225				
	0.9	34	0.8	1500			4.7	58	1.5	300				
	0.8	34	0.8	1800			3.1	82	1.1	450	<b>CMM 030/040</b>			
	0.6	28	0.8	2400			2.3	104	0.9	600				
	0.5	25	0.8	3000			1.6	113	0.8	900				
	0.4	23	0.8	3600			9.3	36	2.4	150	<b>CMM 030/040</b>			
	9.3	23	1.7	150	7.0		46	1.6	200					
	6.2	32	1.2	225	5.6		55	1.2	250					
	4.7	37	1.1	300	4.7	59	1.5	300						
	3.1	50	0.8	450	3.5	72	1.0	400						
	2.3	50	0.8	600	2.8	81	0.8	500						
	1.6	50	0.8	900	2.3	105	0.9	600						
	1.2	50	0.8	1200	1.9	113	0.8	750						
	0.9	50	0.8	1500	1.6	113	0.8	900						
	0.8	50	0.8	1800										
	0.6	43	0.8	2400										
	0.5	38	0.8	3000										
	0.4	34	0.8	3600										
	9.3	23	3.7	150	<b>0.09</b>									
	6.2	33	2.6	225	SMT5034	9.3	49	0.8	150	<b>CMM 026/030</b>				
	4.7	39	2.3	300	SMM5034	6.2	49	0.8	225					
	3.1	55	1.6	450	SMT5624		9.3	53	1.6	150	<b>CMM 026/040</b>			
	2.3	69	1.3	600	SMM5624							6.2	74	1.2
	1.6	92	1.0	900	(1400 min <sup>-1</sup> )						4.7	87	1.0	300
	1.2	113	0.8	1200							3.1	113	0.8	450
	0.9	113	0.8	1500	2.3						113	0.8	600	
	0.8	113	0.8	1800	9.3						53	1.6	150	<b>CMM 030/040</b>
	0.6	93	0.8	2400	7.0						69	1.1	200	
	0.5	85	0.8	3000	5.6						83	0.8	250	
	0.4	78	0.8	3600	4.7						88	1.0	300	
	9.3	24	3.7	150	3.5						93	0.8	400	
	7.0	31	2.4	200	2.8						85	0.8	500	
	5.6	37	1.8	250	2.3						113	0.8	600	
	4.7	39	2.3	300										
	3.5	48	1.6	400										
	2.8	54	1.3	500										
	2.3	70	1.3	600										
	1.9	84	1.1	750										
	1.6	94	1.0	900										
	1.2	113	0.8	1200										
	0.9	113	0.8	1500										
	0.8	113	0.8	1800										
	0.6	93	0.8	2400										
	0.5	85	0.8	3000										

**Nota:** Verificare sempre che la coppia M2 utilizzata non ecceda il valore indicato nelle caselle in grigio  
**Note:** Please check that the output torque M2 does not exceed the value into the grey areas

Motori Motors	SMT		SMM	
		5014 5024 5034	5624	5014 5024 5034
<b>IEC</b>	<b>56 B14</b>		<b>56 B14</b>	



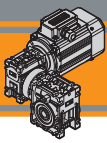



**Dati tecnici**

**Technical data**

P <sub>1</sub> [kW]	n <sub>2</sub> [min <sup>-1</sup> ]	M <sub>2</sub> [Nm]	sf	i	
------------------------	--	------------------------	----	---	---

P <sub>1</sub> [kW]	n <sub>2</sub> [min <sup>-1</sup> ]	M <sub>2</sub> [Nm]	sf	i	
------------------------	--	------------------------	----	---	---

**0.12**

SMT5044	<b>9.3</b>	70	1.2	150	<b>CMM</b> <b>026/040</b>
SMT5634	<b>6.2</b>	99	0.9	225	
SMM5634 (1400 min <sup>-1</sup> )	<b>4.7</b>	113	0.8	300	
	<b>9.3</b>	71	1.2	150	<b>CMM</b> <b>030/040</b>
	<b>7.0</b>	92	0.8	200	
	<b>5.6</b>	84	0.8	250	
	<b>4.7</b>	113	0.8	300	

**0.18**

SMT6324	<b>9.3</b>	107	0.8	150	<b>CMM</b> <b>030/040</b>
SMM6324 (1400 min <sup>-1</sup> )	<b>7.0</b>	93	0.8	225	
					

**0.25**

SMT5654	<b>9.3</b>	109	0.8	150	<b>CMM</b> <b>030/040</b>
SMT6334					
SMM6334 (1400 min <sup>-1</sup> )					



**0.18**

SMT5644	<b>9.3</b>	105	0.8	150	<b>CMM</b> <b>026/040</b>
SMM5644 (1400 min <sup>-1</sup> )	<b>6.2</b>	109	0.8	225	
	<b>9.3</b>	107	0.8	150	<b>CMM</b> <b>030/040</b>
	<b>7.0</b>	93	0.8	200	

**Nota:** Verificare sempre che la coppia M2 utilizzata non ecceda il valore indicato nelle caselle in grigio

**Note:** Please check that the output torque M2 does not exceed the value into the grey areas



Motori Motors	SMT			SMM	
	5044	5644 5654	6324 6334	5634 5644	6324 6334
<b>IEC</b>	56 B14		63 B14	56 B14	63 B14

**Dati tecnici elettrici**

**Electrical technical data**



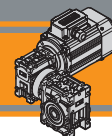

Motori applicabili

Motor adapters

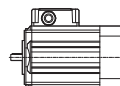
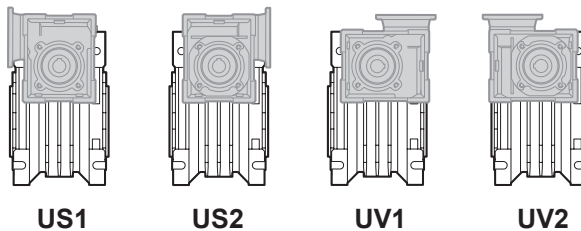

		<b>SMT</b>		<b>SMM</b>	
		5014	5624	5014	5624
		5024	5634	5024	5634
		5034	5644	5034	5644
		5044	5654		
<b>CM</b>	<b>026/026</b>	150 - 3600		150 - 3600	

150 - 3600 Rapporti di riduzione i / Ratio i

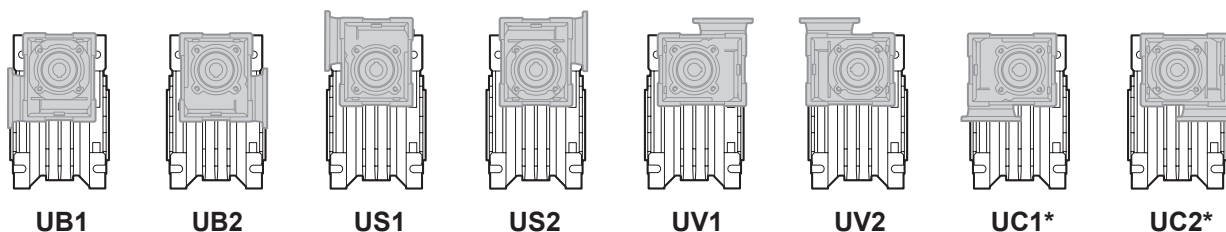

\*: Solo / only SMT 50 - SMM50

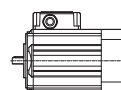

		<b>SMT</b>		<b>SMM</b>	
		5014	5624	5014	5624
		5024	5634	5024	5634
		5034	5644	5034	5644
		5044	5654		
<b>CM</b>	<b>026/030</b>	150 - 3600		150 - 3600	
	<b>026/040</b>				

150 - 3600 Rapporti di riduzione i / Ratio i

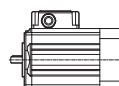
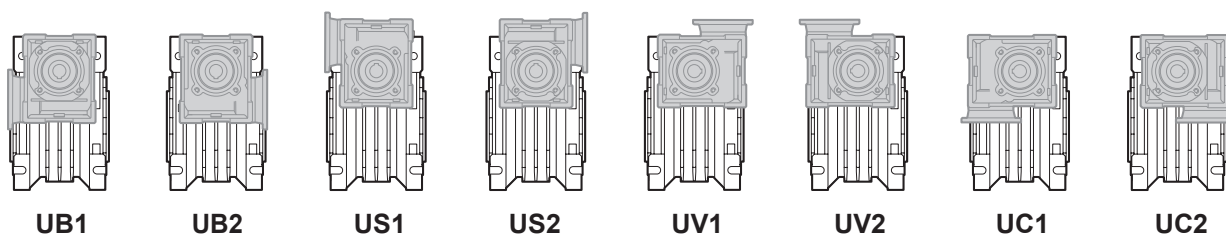

		<b>SMT</b>			<b>SMM</b>		
		5014	5624	6324	5014	5624	6314
		5024	5634	6334	5024	5634	6324
		5034	5644	6344	5034	5644	6334
		5044	5654				
<b>CM</b>	<b>030/040</b>	75 - 3600		75-1500	75 - 3600		75-1500

75 - 3600 Rapporti di riduzione i / Ratio i

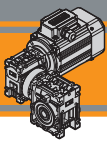

**Dimensioni**

**Dimensions**

CMM..U - CMM..F...																	
	A	C	D <sub>H8</sub>	E	F	G	G1	H	H1	I	I1	K	L	M	N <sub>h8</sub>	N1	N2
026/026 (D11)			11														
026/026	45	70	12	83	22	47.5	50	35	34	26	26	34	42	55	45	22.5	21
026/026 (D14)			14														
026/030	54	80	14	97	32	47.5	63	40	34	30	26	44	56	65	55	29	21
026/040	70	100	18	121.5	43	47.5	78	50	34	40	26	60	71	75	60	36.5	21

CMM..U - CMM..F...														
	O	P	Q	R	R1	S	T	V	Z	KE	a	b	t	Kg
026/026 (D11)												4	12.8	
026/026	6	—	37	49	49	5	15	21	76	7	—	4	13.8	1.6
026/026 (D14)												5	16.2	
026/030	6.5	75	44	57	49	5.5	22	27	81	M6x10(n.4)	90°	5	16.3	2.4
026/040	6.5	87	55	71.5	49	6.5	26	35	91.5	M6x8(n.4)	45°	6	20.8	3.5

	CMM..F						CMM..F28						CMM..F30						CMM..F30S <sup>(1)</sup>														
	a1	KA	KB	KC	KM	KN <sub>H8</sub>	KO	KP	KQ	KA	KB	KC	KM	KN <sub>H8</sub>	KO	KP	KQ	KA	KB	KC	KM	KN <sub>H8</sub>	KO	KP	KQ	KA	KB	KC	KM	KN <sub>H8</sub>	KO	KP	KQ
026 (D11)	45°	45	6	4.5	55-69	40	6.5 (n.4)	75	70	44	6.5	5	56-64	40	6.5	70	60	48	6.5	5	68	50	6.5	80	70	50	8.5	7	68	50	6.5	80	70
026																																	
026 (D14)																																	

(1): F30S eseguita con F30 e distanziale di spessore 2 mm / F30S made with F30 and spacer with 2mm thickness

	CMM..F30C						CMM..F30SC <sup>(2)</sup>						CMM..F100												
	a1	KA	KB	KC	KM	KN <sub>H8</sub>	KO	KP	KQ	KA	KB	KC	KM	KN <sub>H8</sub>	KO	KP	KQ	KA	KB	KC*	KM	KN <sub>H7</sub>	KO	KP	KQ
026 (D11)	-	48	6.5	7	68	50	6.5	80	70	50	8.5	7	68	50	6.5	80	70	51.5	8	2*	86	45	6.5	100	-
026																									
026 (D14)																									

(2): F30SC eseguita con F30C e distanziale di spessore 2 mm / F30SC made with F30C and spacer with 2mm thickness

	CMM..F						CMM..FB						CMM..FL												
	a1	KA	KB	KC	KM	KN <sub>H8</sub>	KO	KP	KQ	KA	KB	KC	KM	KN <sub>H8</sub>	KO	KP	KQ	KA	KB	KC	KM	KN <sub>H8</sub>	KO	KP	KQ
026/030	45°	54.5	6	4	68	50	6.5(n.4)	80	70								—								
026/040	45°	67	7.5	4.5	80-95	60	9(n.4)	110	95	80	8.5	5	115-125	95	9.5(n.4)	140	112	97	7.5	4.5	80-95	60	9(n.4)	110	95

SMT	BFC	BNV	LFC	LNV
5014	□ 85	□ 80	135.5	108.5
5024			150.5	123.5
5034			175.5	148.5
5044			200.5	173.5
5624	□ 93	□ 87	141	117
5634			151	127
5644			186	162
5654			206	182

SMM	BFC	BNV	LFC	LNV
5014	□ 85	□ 80	150.5	123.5
5024			175.5	148.5
5034			200.5	173.5
5624			151	127
5634	□ 93	□ 87	186	162
5644			206	182

Nota: il condensatore sarà fornito a corredo  
Note: the capacitor will be supplied separately

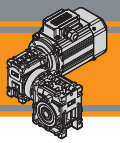

Dimensioni

Dimensions

CMM 026/... U

S3 servizio 30%  
duty

SMT...TENV  
SMM... TENV

SMT...TEFC  
SMM... TEFC

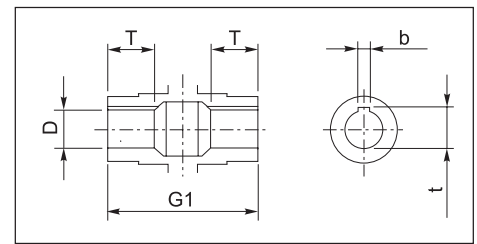
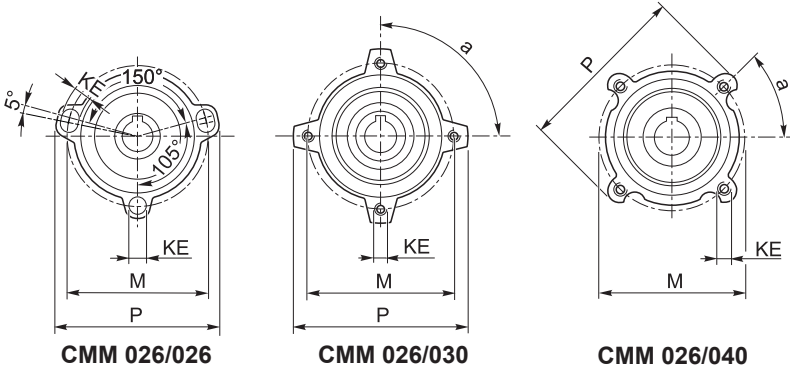
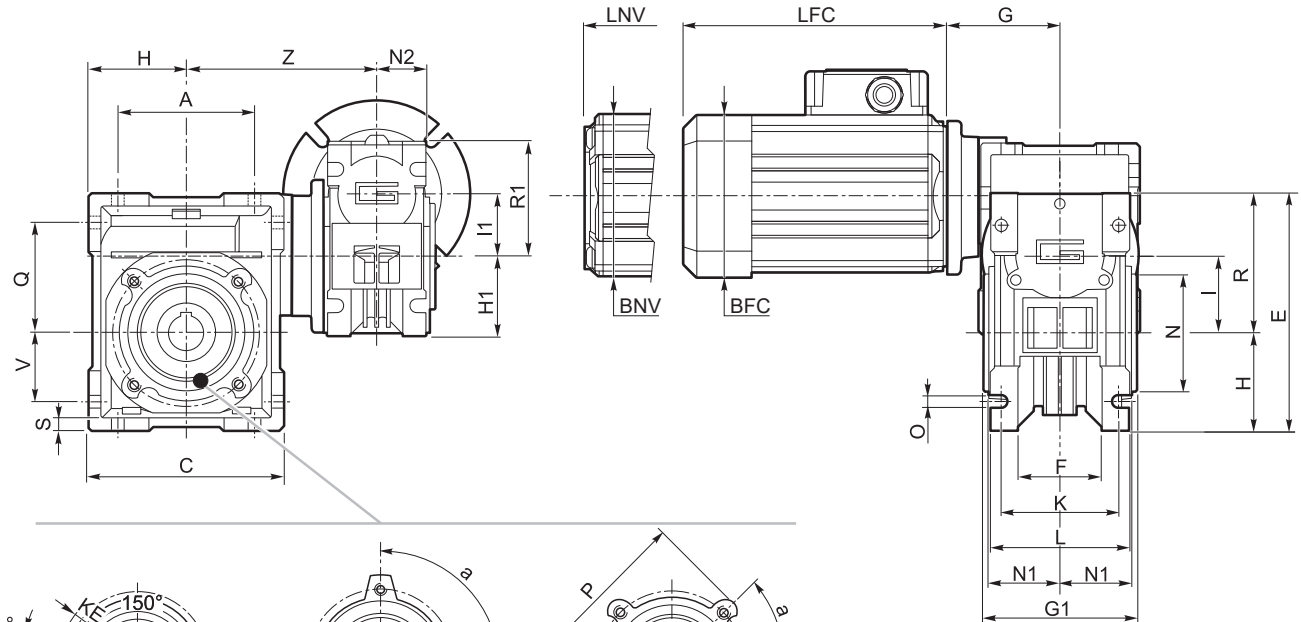

Albero lento cavo / Hollow output shaft

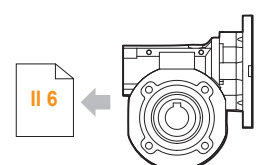
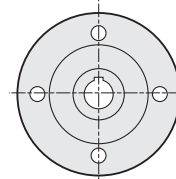
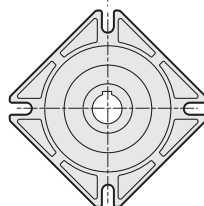
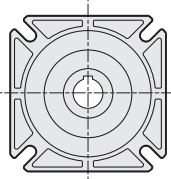
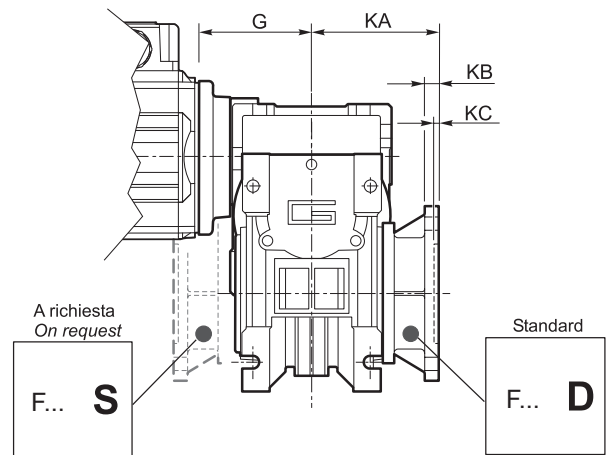
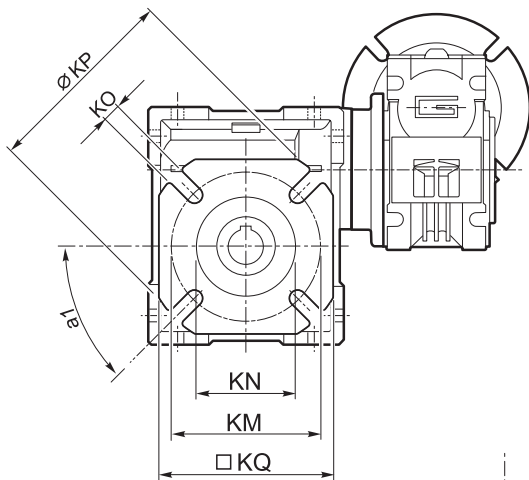

CMM026/026.. F  
CMM026/026.. F28  
CMM026/026.. F30  
CMM026/026.. F30S  
CMM026/030.. F..  
CMM026/040.. F..

CMM026/026.. F30C  
CMM026/026.. F30SC

CMM026/026.. F100

CL026  
CL030  
CL040



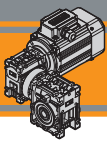

**Dimensioni**

**Dimensions**

CMM.. - CMM..F - CMM..FB - CMM..FL																	
	A	C	D <sub>H8</sub>	E	F	G	G1	H	H1	I	I1	K	L	M	N <sub>H8</sub>	N1	N2
030/040	70	100	18	121.5	43	55	78	50	40	40	30	60	71	75	60	36.5	29

CMM.. - CMM..F - CMM..FB - CMM..FL															
	O	P	Q	R	R1	S	T	V	Z	KE	a	b	t	Kg	
030/040	6.5	87	55	71.5	57	6.5	26	35	122	M6x8(n.4)	45°	6	20.8 (21.8)	3.9	

	CMM..F								CMM..FB								CMM..FL								
	a1	KA	KB	KC	KM	KN <sub>H8</sub>	KO	KP	KQ	KA	KB	KC	KM	KN <sub>H8</sub>	KO	KP	KQ	KA	KB	KC	KM	KN <sub>H8</sub>	KO	KP	KQ
030/040	45°	67	7.5	4	80-95	60	9(n.4)	110	95	80	8.5	5	115-125	95	9.5(n.4)	140	112	97	7.5	4.5	80-95	60	9(n.4)	110	95

SMT	BFC	BNV	LFC	LNv
5014	□ 85	□ 80	135.5	108.5
5024			150.5	123.5
5034			175.5	148.5
5044			200.5	173.5
5624	□ 93	□ 87	141	117
5634			151	127
5644			186	162
5654			206	182
6324	□ 105	□ 97	165.5	138.5
6334			180.5	153.5
6344			205.5	178.5

SMM	BFC	BNV	LFC	LNv
5014	□ 85	□ 80	150.5	123.5
5024			175.5	148.5
5034			200.5	173.5
5624	□ 93	□ 87	151	127
5634			186	162
5644			206	182
6324	□ 105	□ 97	180.5	153.5
6334			205.5	178.5

**Nota:** il condensatore sarà fornito a corredo  
**Note:** the capacitor will be supplied separately

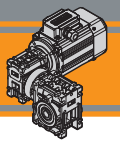

Dimensioni

Dimensions

**CMM 030/040 U**

S3 servizio duty 30% SMT...TENV SMM... TENV

SMT...TEFC SMM... TEFC

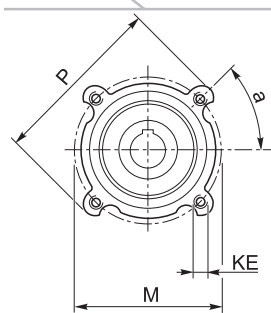
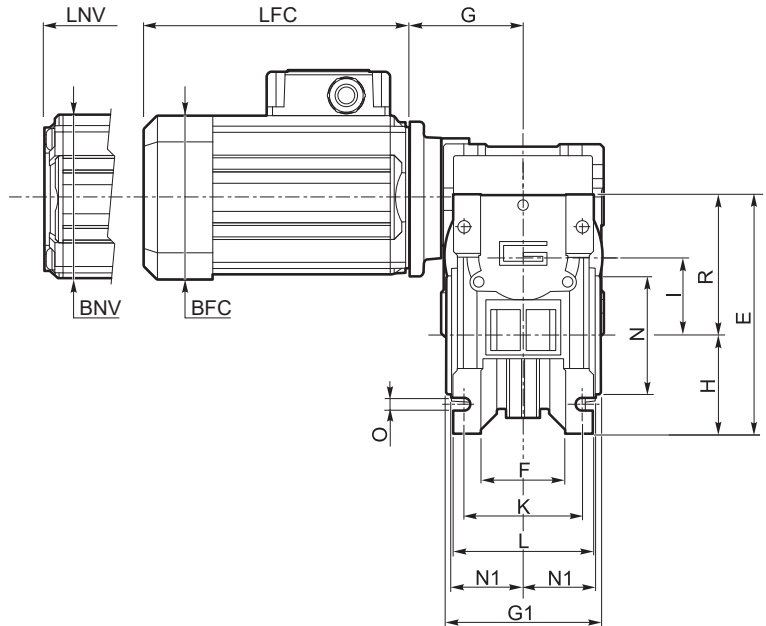
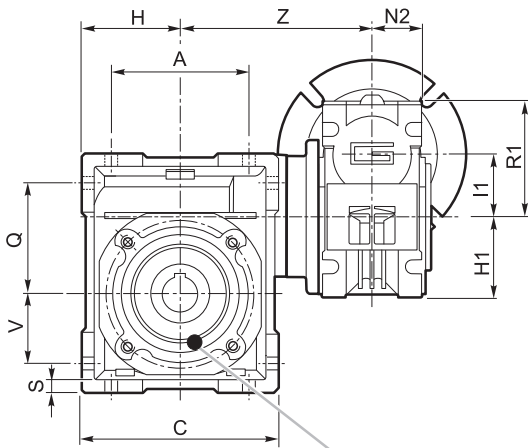

**CMM 030/040**

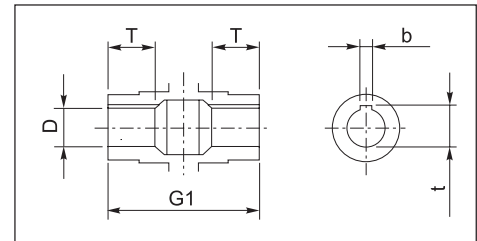

Albero lento cavo / Hollow output shaft

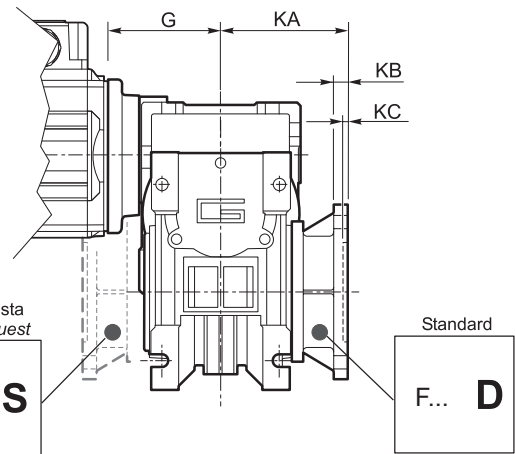
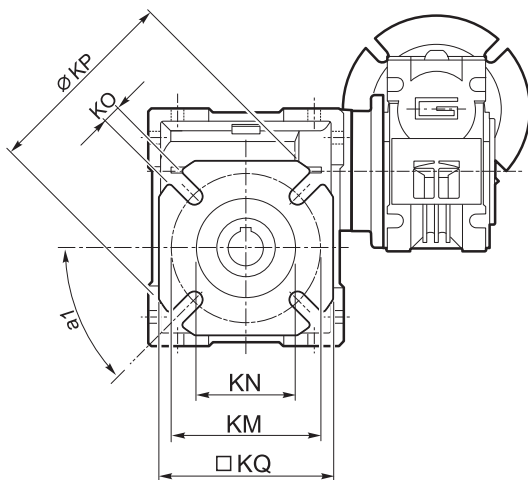

II 9  
II 10

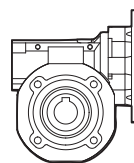

**CL030  
CL040**

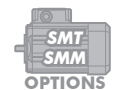

AB1  
AC1  
AD1

AC

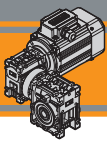

Opzioni

Options

**VS1 - VS2 - Vite sporgente / Extended input shaft**

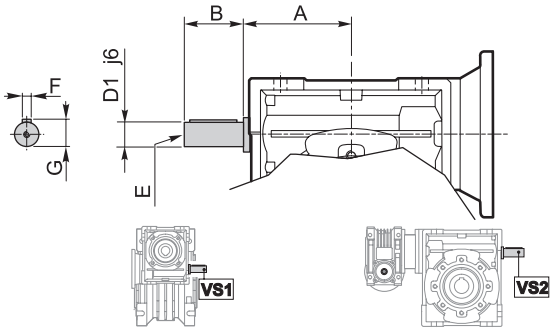

CMM	VS1						VS2					
	A	B	D <sub>1</sub> j6	E	F	G	A	B	D <sub>1</sub> j6	E	F	G
026/030	—	—	—	—	—	—	45	20	9	M4	3	10.2
026/040	—	—	—	—	—	—	53	23	11	M5	4	12.5
030/040	45	20	9	M4	3	10.2	53	23	11	M5	4	12.5

Costruito su richiesta  
Built on request

Accessori

Accessories

**Albero lento semplice e doppio**

**Single and double output shaft**

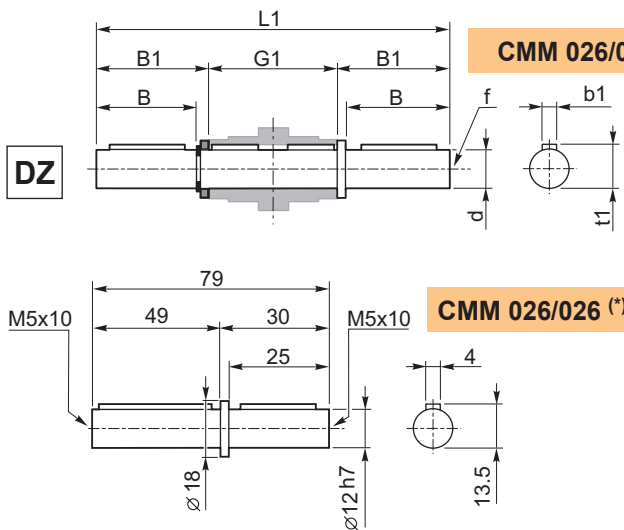

CMM 026/030 - CMM 030/040

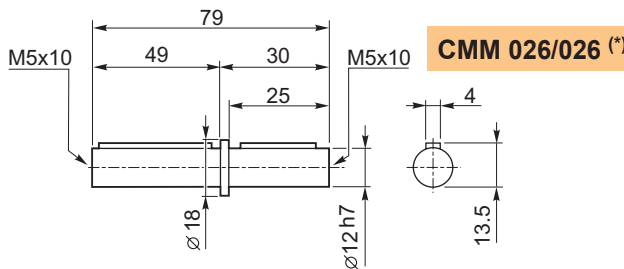
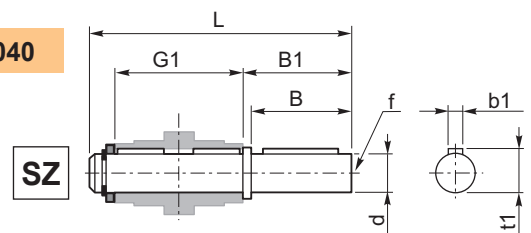

CMM 026/026 (\*)

CMM	d h7	B	B1	G1	L	L1	f	b1	t1
026/030	14	30	32.5	63	102	128	M6	5	16
026/040 030/040	18	40	43	78	128	164	M6	6	20.5

(\*)  
Nota: disponibile solo per cavo uscita Ø12  
Note: available for output hollow shaft Ø12 only

**Braccio di reazione**

**Torque arm**

CMM	K1	G	KG	KH	R
026/030	85	14	23	8	15
026/040 030/040	100	14	31	10	18

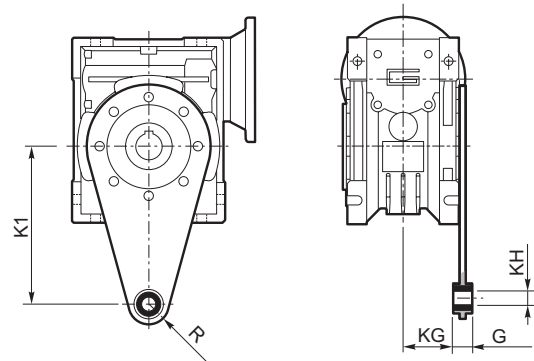

**SC - Safety cover**

**WD - Kit washdown cover**

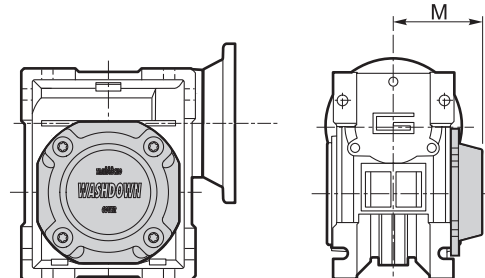
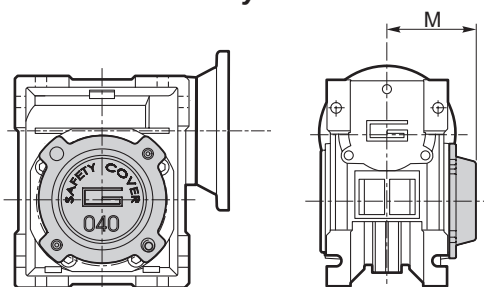

M	CM	
	30	40
M	47	54.5

M	CM	
	30	40
M	48	55.5

**MINI**  **TECNO**™  
**small** but strong

**PM**

**AC**

**Motoriduttori CA epicicloidali**  
**AC Planetary gearmotors**



**MINI**  **TECNO**™ brand of  
**TRANSTECNO**®





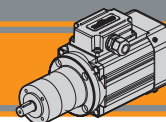

<b>Indice</b>	<b>Index</b>	Pag. Page
Caratteristiche tecniche	<i>Technical features</i>	<b>AL2</b>
Designazione	<i>Classification</i>	<b>AL2</b>
Versioni	<i>Versions</i>	<b>AL2</b>
Simbologia	<i>Symbols</i>	<b>AL3</b>
Lubrificazione	<i>Lubrication</i>	<b>AL3</b>
Carichi radiali	<i>Radial loads</i>	<b>AL3</b>
Rapporti	<i>Ratios</i>	<b>AL3</b>
Dati tecnici	<i>Technical data</i>	<b>AL4</b>
Motori applicabili	<i>IEC Motor adapters</i>	<b>AL8</b>
Dimensioni	<i>Dimensions</i>	<b>AL8</b>

Questa sezione annulla e sostituisce ogni precedente edizione o revisione. Qualora questa sezione non Vi sia giunta in distribuzione controllata, l'aggiornamento dei dati ivi contenuto non è assicurato. **In tal caso la versione più aggiornata è disponibile sul nostro sito internet [www.transtecno.com](http://www.transtecno.com)**

*This section replaces any previous edition and revision. If you obtained this catalogue other than through controlled distribution channels, the most up to date content is not guaranteed. In this case the latest version is available on our web site [www.transtecno.com](http://www.transtecno.com)*

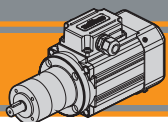

**PM**

**Motoriduttori CA epicicloidali**  
**AC planetary gearmotors**



**Caratteristiche tecniche**

**Technical features**

Le caratteristiche principali dei motoriduttori PM sono:

- Costruzione compatta
- Motorizzazioni in corrente alternata monofase e trifase
- Carcassa motore estrusa in alluminio anodizzato nero
- Motore elettrico AC con grado di protezione IP66
- Disponibili sia nella versione ventilata TEFC (servizio S1) che non ventilata TENV (servizio S3)
- Protezione termica PTO 150°C per le taglie motore 56 e 63.
- SMT56 e SMT63 adatti al funzionamento con alimentazione da inverter
- Disponibili nelle versioni autofrenante, servoventilata e con certificazione UL.

PM gearmotors gearmotors have the following main features:

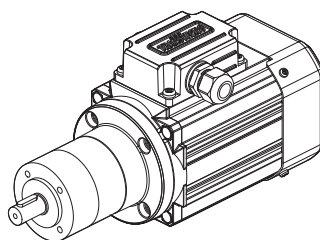

- Compact design
- AC single phase and three phase motors available
- Motor extruded aluminum housing black anodized
- AC electric motor in IP66 protection Standard
- Fan cooled TEFC (duty S1) and not ventilated TENV (duty S3) versions available
- PTO 150°C thermal protection for motor sizes 56 and 63.
- SMT56 and SMT63 are suitable for inverter duty
- Brake motors, forced ventilation motors and UL compliance versions available.



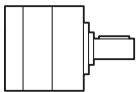

**Designazione**

**Classification**

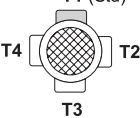
RIDUTTORE / GEARMOTOR				
PM	52	2	C80	34.97
Tipo Type	Grandezza Size	Stadi riduttore Gearbox stages	Versione riduttore Gearbox Version	Rapporto Ratio
<b>PM</b> 	<b>52</b> <b>62</b>	<b>1</b> <b>2</b> <b>3</b>	<b>U</b> <b>C80</b> <b>C90</b> <b>C105</b> <b>C120</b>	Vedere tabella See tables

MOTORE TRIFASE / THREE PHASE MOTOR										
SMT	63	2	4	0.18 kW	B14	230-400 V	50 Hz	TEFC	BR	T1
Tipo Type	Grandezza Size	Indicativo potenza Power coefficient	Poli Poles	Potenza Power	Forma costruttiva Version	Tensione Voltage	Frequenza Frequency	Ventilazione Fan cooling	Opzioni Options	Pos. Morsettiera Terminal box pos.
<b>SMT</b> 	Vedere tab. See tab.	<b>1-2-3-4-5</b>	<b>4</b>	<b>0.04 kW</b> ... <b>0.37 kW</b>	<b>B14</b>	<b>230-400 V</b>  <b>460V</b>	<b>50Hz</b>  <b>60Hz</b>	<b>TEFC</b>  <b>TENV</b>		<b>T1 (Std)</b> 

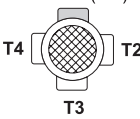
MOTORE MONOFASE / SINGLE PHASE MOTOR										
SMM	63	2	4	0.18 kW	B14	230 V	50 Hz	TEFC	UL-CSA	T1
Tipo Type	Grandezza Size	Indicativo potenza Power coefficient	Poli Poles	Potenza Power	Forma costruttiva Version	Tensione Voltage	Frequenza Frequency	Ventilazione Fan cooling	Opzioni Options	Pos. Morsettiera Terminal box pos.
<b>SMM</b> 	Vedere tab. See tab.	<b>1-2-3-4</b>	<b>4</b>	<b>0.04 kW</b> ... <b>0.25 kW</b>	<b>B14</b>	<b>230V</b>	<b>50Hz</b>	<b>TEFC</b>  <b>TENV</b>		<b>T1 (Std)</b> 

**Versioni**

**Versions**

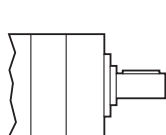

**U**

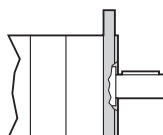

**C**

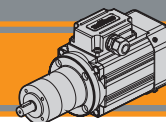

**Simbologia**

**Symbols**

$n_1$ [min <sup>-1</sup> ]	Velocità in ingresso / <i>Input speed</i>	$sf$	Fattore di servizio / <i>Service factor</i>
$n_2$ [min <sup>-1</sup> ]	Velocità in uscita / <i>Output speed</i>	Rd %	Rendimento dinamico / <i>Dynamic efficiency</i>
$i$	Rapporto di riduzione / <i>Ratio</i>	$A_2$ [N]	Carico assiale ammissibile in uscita / <i>Permitted output axial load</i>
$P_1$ [kW]	Potenza in entrata / <i>Input power</i>	$R_2$ [N]	Carico radiale ammissibile in uscita / <i>Permitted output radial load</i>
$M_2$ [Nm]	Coppia in uscita in funzione di $P_1$ / <i>Output torque referred to <math>P_1</math></i>		

**Lubrificazione**

**Lubrication**

I riduttori epicicloidali sono lubrificati in modo permanente, non richiedono quindi ulteriore manutenzione. Questo gli consente di essere installati praticamente ovunque.

*Planetary gearboxes are life-time lubricated with grease, therefore they are maintenance free. They can be installed in any location.*

**Carichi radiali**

**Radial loads**

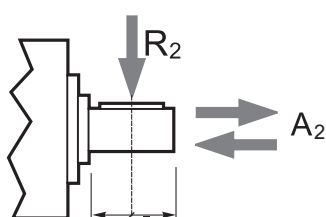

Numero di stadi Stages number	Carichi Radiali $R_2$ [N] / Radial Load $R_2$ [N]	
	PM52	PM62
1	200	240
2	320	360
3	450	520

Numero di stadi Stages number	Carichi Assiali $A_2$ [N] / Axial Load $A_2$ [N]	
	PM52	PM62
1	60	70
2	100	100
3	150	150

**Rapporti**

**Ratios**

Numero di stadi Stages number	Per tutte le grandezze di riduttori della serie PM For all gearbox sizes of PM range	
	Rapporti / Ratios	
1	3.70	
	4.28	
	5.18	
	6.75	
2	13.73	
	15.88	
	18.36	
	19.20	
	22.20	
	25.01	
	26.85	
	28.93	
	34.97	
	45.56	
3	50.89	
	58.85	
	68.06	
	71.16	
	78.71	
	92.70	
	95.17	
	99.50	
	107.20	
	115.07	
	123.97	
	129.62	
	139.13	
	149.90	
	168.84	
181.24		
195.26		
236.09		
307.54		

**Rapporti preferenziali per le taglie PM52, PM62.**  
*Preferred ratios for PM52, PM62.*

Disponibile a 4 stadi con rapporti fino a 2076  
*Available 4 stages with ratio up to 2076*



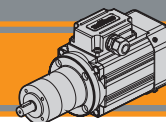

## Dati tecnici

## Technical data

P <sub>1</sub> [kW]	n <sub>2</sub> [min <sup>-1</sup> ]	M <sub>2</sub> [Nm]	sf	i		P <sub>1</sub> [kW]	n <sub>2</sub> [min <sup>-1</sup> ]	M <sub>2</sub> [Nm]	sf	i	
<b>0.06</b>						<b>0.09</b>					
SMT5024	<b>56</b>	8	4.1	25.01	<b>PM622</b>	SMT5034	<b>56</b>	12	2.7	25.01	<b>PM622</b>
SMM5024	<b>52</b>	8	3.8	26.85		SMM5034	<b>52</b>	12	2.6	26.85	
(1400 min <sup>-1</sup> )	<b>48</b>	9	3.6	28.93		SMT5624	<b>48</b>	13	2.4	28.93	
	<b>40</b>	11	2.9	34.97		SMM5624	<b>40</b>	16	2.0	34.97	
	<b>31</b>	14	2.3	45.56		(1400 min <sup>-1</sup> )	<b>31</b>	21	1.5	45.56	
	<b>28</b>	15	4.3	50.89	<b>PM623</b>		<b>28</b>	22	2.9	50.89	<b>PM623</b>
	<b>24</b>	17	3.8	58.85			<b>24</b>	25	2.5	58.85	
	<b>21</b>	19	3.2	68.06			<b>21</b>	29	2.2	68.06	
	<b>20</b>	20	3.1	71.16			<b>20</b>	31	2.1	71.16	
	<b>18</b>	23	2.8	78.71			<b>18</b>	34	1.9	78.71	
	<b>15</b>	27	2.4	92.7			<b>15</b>	40	1.6	92.7	
	<b>15</b>	27	2.3	95.17			<b>15</b>	41	1.5	95.17	
	<b>14</b>	29	2.2	99.5			<b>14</b>	43	1.5	99.5	
	<b>13</b>	31	2.1	107.2			<b>13</b>	46	1.4	107.2	
	<b>12</b>	33	1.9	115.07			<b>12</b>	49	1.3	115.07	
	<b>11</b>	36	1.8	123.97			<b>11</b>	53	1.2	123.97	
	<b>11</b>	37	1.7	129.62			<b>11</b>	56	1.1	129.62	
	<b>10</b>	40	1.6	139.13			<b>10</b>	60	1.1	139.13	
	<b>9.3</b>	43	1.5	149.9		<b>9.3</b>	64	1.0	149.9		
	<b>8.3</b>	48	1.3	168.84		<b>8.3</b>	73	0.9	168.84		
	<b>7.7</b>	52	1.2	181.24		<b>7.7</b>	78	0.8	181.24		
	<b>7.2</b>	56	1.1	195.26		<b>7.2</b>	84	0.8	195.26		
	<b>5.9</b>	68	0.9	236.09		<b>5.9</b>	90	0.7	236.09		
	<b>4.6</b>	88	0.7	307.54		<b>4.6</b>	90	0.7	307.54		

<b>0.09</b>						<b>0.12</b>								
SMT5034	<b>378</b>	2	2.8	3.7	<b>PM521</b>	SMT5044	<b>378</b>	2	2.1	3.7	<b>PM521</b>			
SMM5034	<b>327</b>	2	2.4	4.28		SMT5634	<b>327</b>	3	1.8	4.28				
SMT5624	<b>270</b>	3	2.0	5.18		SMM5634	<b>270</b>	3	1.5	5.18				
SMM5624	<b>207</b>	3	1.5	6.75		(1400 min <sup>-1</sup> )	<b>207</b>	4	1.1	6.75				
(1400 min <sup>-1</sup> )	<b>102</b>	6	2.4	13.73	<b>PM522</b>		<b>102</b>	8	1.8	13.73	<b>PM522</b>			
	<b>88</b>	7	2.1	15.88			<b>88</b>	10	1.6	15.88				
	<b>76</b>	8	1.8	18.36			<b>76</b>	11	1.3	18.36				
	<b>73</b>	9	1.7	19.2			<b>73</b>	12	1.3	19.2				
	<b>63</b>	10	1.5	22.2			<b>63</b>	14	1.1	22.2				
	<b>56</b>	12	1.3	25.01			<b>56</b>	15	1.0	25.01				
	<b>52</b>	12	1.2	26.85			<b>52</b>	16	0.9	26.85				
	<b>48</b>	13	1.1	28.93			<b>48</b>	18	0.9	28.93				
	<b>40</b>	16	0.9	34.97			<b>40</b>	22	0.7	34.97				
	<b>31</b>	21	0.7	45.56			<b>31</b>	22	0.7	45.56				
	<b>28</b>	22	1.4	50.89		<b>PM523</b>								
	<b>24</b>	25	1.3	58.85										
	<b>21</b>	29	1.1	68.06										
	<b>20</b>	31	1.0	71.16										
	<b>18</b>	34	0.9	78.71										
	<b>15</b>	40	0.8	92.7										
	<b>15</b>	41	0.8	95.17										
	<b>14</b>	45	0.7	99.5										
	<b>13</b>	45	0.7	107.2										
	<b>12</b>	45	0.7	115.07										
	<b>11</b>	45	0.7	123.97										
	<b>11</b>	45	0.7	129.62										
	<b>10</b>	45	0.7	139.13										

NOTA  
Per sf=0.7 verificare che la coppia utilizzata non ecceda il valore M2 indicato.





NOTE  
For sf=0.7 check that the duty torque does not exceed the value M2

Motoriduttori preferenziali / Preferred gearmotors

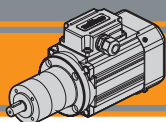

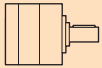
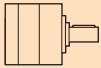
Motori Motors	SMT		SMM	
		5014 5024 5034 5044	5624 5634	5024 5034
IEC	56 B14		56 B14	

**PM****Motoriduttori CA epicicloidali  
AC planetary gearmotors****MINI  
TECNO****Dati tecnici****Technical data**

$P_1$ [kW]	$n_2$ [min <sup>-1</sup> ]	$M_2$ [Nm]	sf	i		$P_1$ [kW]	$n_2$ [min <sup>-1</sup> ]	$M_2$ [Nm]	sf	i		
<b>0.12</b>						<b>0.18</b>						
SMT5044	<b>28</b>	29	1.1	50.89	<b>PM523</b>	SMT5644	<b>378</b>	4	1.4	3.7	<b>PM521</b>	
SMT5634	<b>24</b>	34	0.9	58.85		SMM5644	<b>327</b>	4	1.2	4.28		
SMM5634	<b>21</b>	39	0.8	68.06		(1400 min <sup>-1</sup> )	<b>270</b>	5	1.0	5.18		
(1400 min <sup>-1</sup> )	<b>20</b>	41	0.8	71.16			<b>207</b>	7	0.8	6.75		
	<b>18</b>	45	0.7	78.71		<b>102</b>	13	1.2	13.73	<b>PM522</b>		
<b>15</b>	45	0.7	92.7	<b>88</b>		15	1.0	15.88				
<b>15</b>	45	0.7	95.17	<b>76</b>		17	0.9	18.36				
<b>14</b>	45	0.7	99.5	<b>73</b>		18	0.9	19.2				
<b>13</b>	45	0.7	107.2	<b>63</b>		22	0.7	22.2				
<b>12</b>	45	0.7	115.07	<b>56</b>		22	0.7	25.01				
<b>11</b>	45	0.7	123.97	<b>52</b>	22	0.7	26.85					
<b>11</b>	45	0.7	129.62	<b>48</b>	22	0.7	28.93					
<b>10</b>	45	0.7	139.13									
	<b>378</b>	2	4.2	3.7	<b>PM621</b>	<b>28</b>	45	0.7	50.89	<b>PM523</b>		
	<b>327</b>	3	3.6	4.28		<b>24</b>	45	0.7	58.85			
	<b>270</b>	3	3.0	5.18		<b>21</b>	45	0.7	68.06			
	<b>207</b>	4	2.3	6.75		<b>20</b>	45	0.7	71.16			
	<b>102</b>	8	3.8	13.73	<b>PM622</b>	<b>0.18</b>						
	<b>88</b>	10	3.2	15.88		SMT5644	<b>378</b>	4	2.8	3.7	<b>PM621</b>	
	<b>76</b>	11	2.8	18.36		SMM5644	<b>327</b>	4	2.4	4.28		
	<b>73</b>	12	2.7	19.2		SMT6324	<b>270</b>	5	2.0	5.18		
	<b>63</b>	14	2.3	22.2		SMM6324	<b>207</b>	7	1.5	6.75		
	<b>56</b>	15	2.1	25.01		(1400 min <sup>-1</sup> )	<b>102</b>	13	2.5	13.73		<b>PM622</b>
	<b>52</b>	16	1.9	26.85			<b>88</b>	15	2.2	15.88		
	<b>48</b>	18	1.8	28.93		<b>76</b>	17	1.9	18.36			
	<b>40</b>	21	1.5	34.97		<b>73</b>	18	1.8	19.2			
	<b>31</b>	28	1.1	45.56		<b>63</b>	20	1.5	22.2			
					<b>56</b>	23	1.4	25.01				
	<b>28</b>	29	2.2	50.89	<b>52</b>	25	1.3	26.85	<b>PM623</b>			
	<b>24</b>	34	1.9	58.85	<b>48</b>	27	1.2	28.93				
	<b>21</b>	39	1.6	68.06	<b>40</b>	32	1.0	34.97				
	<b>20</b>	41	1.6	71.16	<b>31</b>	42	0.8	45.56				
	<b>18</b>	45	1.4	78.71								
	<b>15</b>	53	1.2	92.7	<b>28</b>	44	1.4	50.89				
	<b>15</b>	55	1.2	95.17	<b>24</b>	51	1.3	58.85				
	<b>14</b>	57	1.1	99.5	<b>21</b>	58	1.1	68.06				
	<b>13</b>	61	1.0	107.2	<b>20</b>	61	1.0	71.16				
	<b>12</b>	66	1.0	115.07	<b>18</b>	68	0.9	78.71				
	<b>11</b>	71	0.9	123.97	<b>15</b>	80	0.8	92.7				
	<b>11</b>	74	0.9	129.62	<b>15</b>	82	0.8	95.17				
	<b>10</b>	80	0.8	139.13	<b>14</b>	86	0.7	99.5				
	<b>9.3</b>	90	0.7	149.9	<b>13</b>	90	0.7	107.2				
	<b>8.3</b>	90	0.7	168.84	<b>12</b>	90	0.7	115.07				
	<b>7.7</b>	90	0.7	181.24	<b>11</b>	90	0.7	123.97				
	<b>7.2</b>	90	0.7	195.26	<b>11</b>	90	0.7	129.62				
					<b>10</b>	90	0.7	139.13				

NOTA  
Per sf=0.7 verificare che la coppia utilizzata non ecceda il valore M2 indicato.

NOTE  
For sf=0.7 check that the duty torque does not exceed the value M2

 Motoriduttori preferenziali / Preferred gearmotors



Motori Motors	SMT			SMM	
	5044	5634 5644	6324	5634 5644	6324
IEC	56 B14			63 B14	



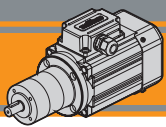

Motori applicabili

IEC Motor adapters

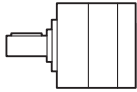
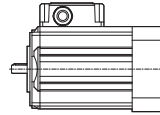

		SMT		SMM		SMT		SMM	
		5014	5624	5014	5624	6324		6324	
		5024	5634	5024	5634	6334		6334	
		5034	5644	5034	5644	6344			
		5044	5654						
PM	52...								
	62...								



Flangia di combainazione  
Combination flange

Dimensioni

Dimensions

PM52 ... U

S3 servizio duty 30% SMT50...TENV  
SMM50... TENV

SMT50...TEFC  
SMM50... TEFC

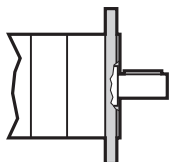
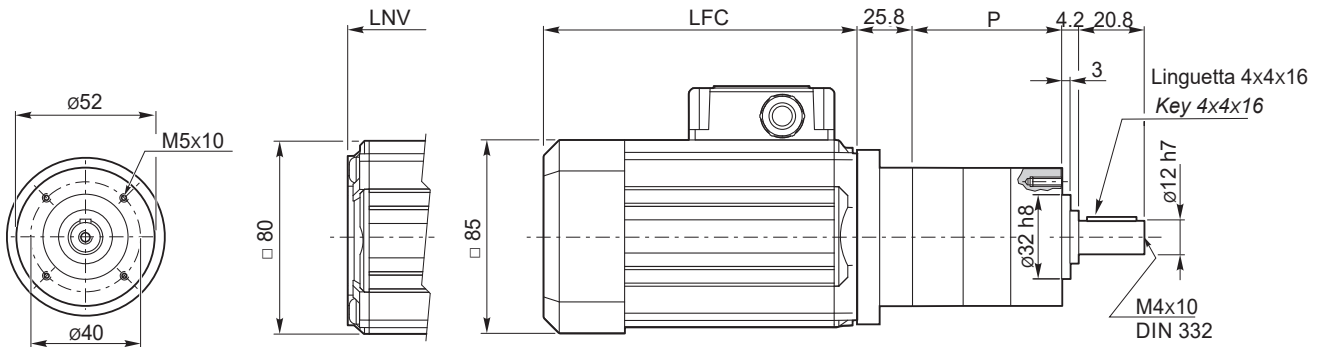

PM52...C



Tipo Type	Numero di stadi Stages number	P
PM52...	1	47.2
	2	61.3
	3	75.6

SMT	LFC	LNv	Kg	
5014	135.5	108.5	3.4	
5024	150.5	123.5	3.8	
5034	175.5	148.5	4.6	
5044	200.5	173.5	5.3	

SMM	LFC	LNv	Kg	
5014	150.5	123.5	3.8	
5024	175.5	148.5	4.6	
5034	200.5	173.5	5.3	

Nota: il condensatore sarà fornito a corredo  
Note: the capacitor will be supplied separately



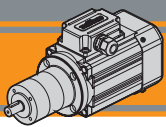

**PM**

Motoriduttori CA epicycloidali  
AC planetary gearmotors

**MINI**  
TECNO

Dimensioni

Dimensions

**PM62 ... U**

S3 servizio  
duty 30%

SMT56...TENV  
SMM56... TENV

SMT56...TEFC  
SMM56... TEFC

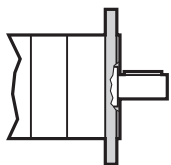
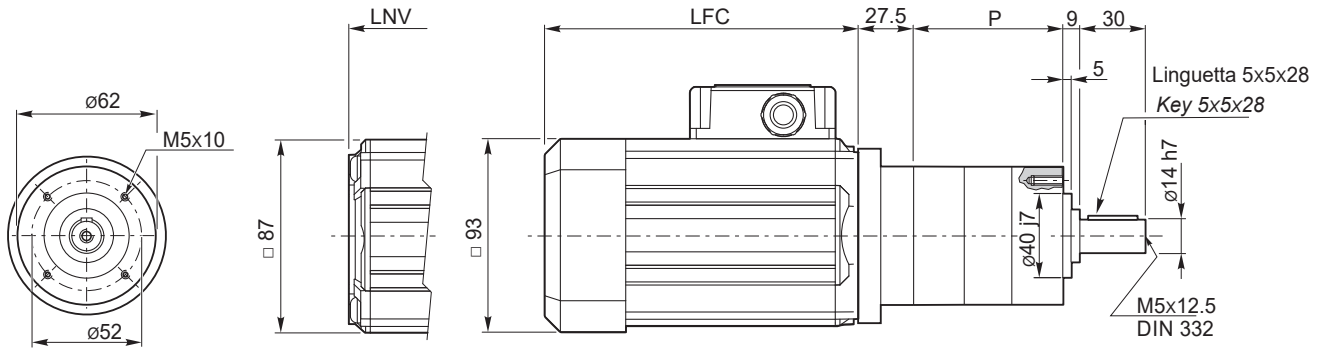

PM62...C

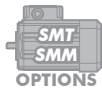

Tipo Type	Numero di stadi Stages number	P
PM62...	1	45.3
	2	62.2
	3	79.2

SMT	LFC	LNV	Kg	
5624	141	117	4.4	
5634	151	127	4.8	
5644	186	162	6	
5654	206	182	6.7	

SMM	LFC	LNV	Kg	
5624	151	127	4.7	
5634	171	147	5.3	
5644	206	182	6.6	

Nota: il condensatore sarà fornito a corredo  
Note: the capacitor will be supplied separately

**PM62 ... U**

S3 servizio  
duty 30%

SMT63...TENV  
SMM63... TENV

SMT63...TEFC  
SMM63... TEFC

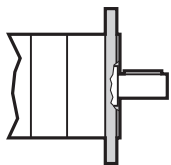
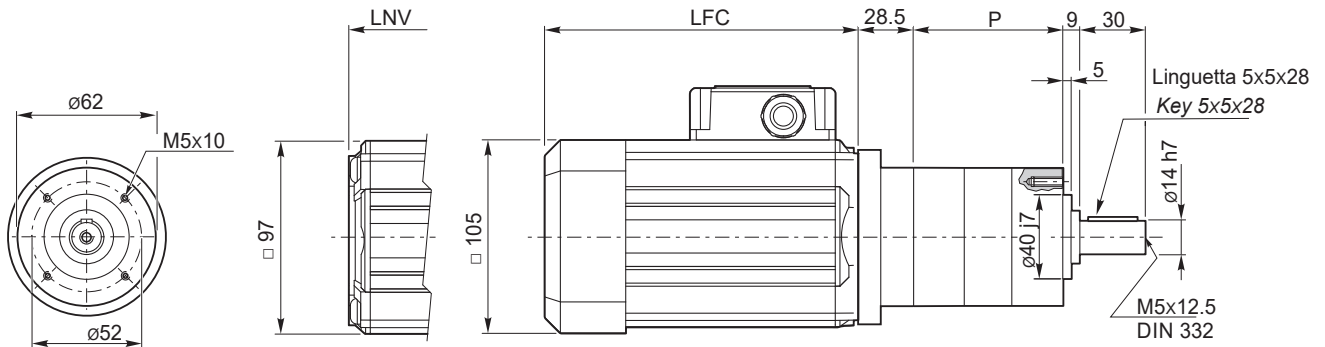

PM62...C

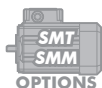

Tipo Type	Numero di stadi Stages number	P
PM62...	1	45.3
	2	62.2
	3	79.2

SMT	LFC	LNV	Kg	
6324	165.5	138.5	5.9	
6334	180.5	153.5	6.6	
6344	205.5	178.5	7.8	

SMM	LFC	LNV	Kg	
6324	180.5	153.5	6.7	
6334	205.5	178.5	7.9	

Nota: il condensatore sarà fornito a corredo  
Note: the capacitor will be supplied separately

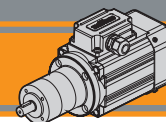

Dimensioni

Dimensions

PM.../... C... Flange uscita / Output flanges

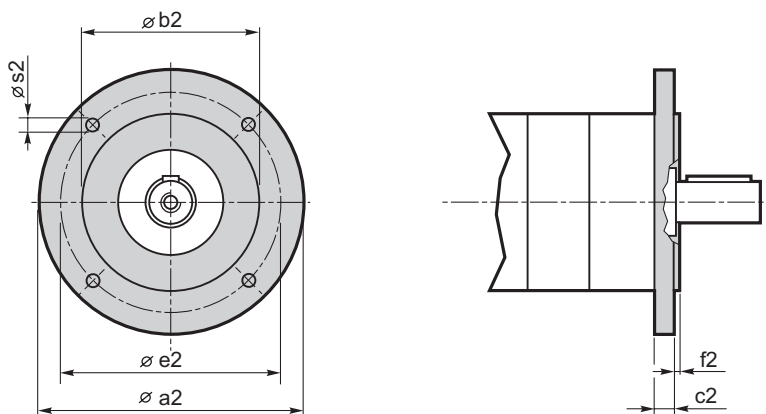

Dimensioni / Dimensions							
PM	a2	b2	c2	e2	f2	s2	Flangia uscita Output flange
52	80	50 j7	9	65	2.5	M5	C80
	90	60 j7	9	75	2.5	5.5	C90
	105	70 j7	9	85	2.5	6.5	C105
	120	80 j7	9	100	3.0	6.5	C120
62	80	50 j7	9	65	2.5	M5	C80
	90	60 j7	9	75	2.5	5.5	C90
	105	70 j7	9	85	2.5	6.5	C105
	120	80 j7	9	100	3.0	6.5	C120



**MINI**  **TECNO**™  
**small** but strong

**WMP**

Motoriduttori CA combinati  
AC Double reduction gearmotors



**MINI**  **TECNO**™ brand of  
**TRANSTECNO**®



AC



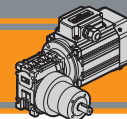

<b>Indice</b>	<b>Index</b>	Pag. Page
Caratteristiche tecniche	<i>Technical features</i>	<b>AM2</b>
Designazione	<i>Classification</i>	<b>AM2</b>
Versioni	<i>Versions</i>	<b>AM2</b>
Simbologia	<i>Symbols</i>	<b>AM3</b>
Lubrificazione	<i>Lubrication</i>	<b>AM3</b>
Carichi radiali	<i>Radial loads</i>	<b>AM3</b>
Rapporti	<i>Ratios</i>	<b>AM3</b>
Dati tecnici	<i>Technical data</i>	<b>AM4</b>
Motori applicabili	<i>IEC Motor adapters</i>	<b>AM5</b>
Dimensioni	<i>Dimensions</i>	<b>AM5</b>

Questa sezione annulla e sostituisce ogni precedente edizione o revisione. Qualora questa sezione non Vi sia giunta in distribuzione controllata, l'aggiornamento dei dati ivi contenuto non è assicurato. **In tal caso la versione più aggiornata è disponibile sul nostro sito internet [www.transtecno.com](http://www.transtecno.com)**

*This section replaces any previous edition and revision. If you obtained this catalogue other than through controlled distribution channels, the most up to date content is not guaranteed. In this case the latest version is available on our web site [www.transtecno.com](http://www.transtecno.com)*

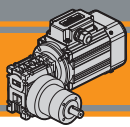

## Caratteristiche tecniche

## Technical features

Le caratteristiche principali dei motoriduttori WMP sono:

- Costruzione compatta
- Motorizzazioni in corrente alternata monofase e trifase
- Carcassa motore estrusa in alluminio anodizzato nero
- Motore elettrico AC con grado di protezione IP66
- Disponibili sia nella versione ventilata TEFC (servizio S1) che non ventilata TENV (servizio S3)
- Protezione termica PTO 150°C per le taglie motore 56.
- SMT56 adatto al funzionamento con alimentazione da inverter
- Disponibili nelle versioni autofrenante, servoventilata e con certificazione UL.

WMP gearmotors gearmotors have the following main features:

- Compact design
- AC single phase and three phase motors available
- Motor extruded aluminum housing black anodized
- AC electric motor in IP66 protection Standard
- Fan cooled TEFC (duty S1) and not ventilated TENV (duty S3) versions available
- PTO 150°C thermal protection for motor sizes 56.
- SMT56 is suitable for inverter duty
- Brake motors, forced ventilation motors and UL compliance versions available.

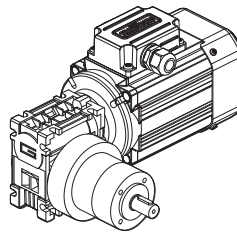

## Designazione

## Classification

RIDUTTORE / GEARMOTOR					
WMP	026/52	2	C	202.5	56 B14
Tipo Type	Grandezza Size	Numero stadi epicicloidale Planetary stages number	Versione riduttore Gearbox Version	Rapporto Ratio	IEC  56 B14
<b>WMP</b> 	<b>026/52</b> <b>026/62</b>	<b>1</b> <b>2</b> <b>3</b>	<b>US</b> <b>UD</b> <b>CS80...120</b> <b>CD80...120</b>	Vedere tabella See tables	

MOTORE TRIFASE / THREE PHASE MOTOR									
SMT	56	3	4	0.12 kW	B14	230-400 V	50 Hz	TEFC	T1
Tipo Type	Grandezza Size	Indicativo potenza Power coefficient	Poli Poles	Potenza Power	Forma costruttiva Version	Tensione Voltage	Frequenza Frequency	Ventilazione Fan cooling	Pos. Morsetti Terminal box pos.
<b>SMT</b> 	Vedere tab. See tab.	<b>1-2-3-4</b>	<b>4</b>	<b>0.04 kW</b> ... <b>0.18 kW</b>	<b>B14</b>	<b>230-400 V</b>  <b>460V</b>	<b>50Hz</b>  <b>60Hz</b>	<b>TEFC</b> 	<b>T1 (Std)</b>  <b>T4</b> <b>T2</b> <b>T3</b>

MOTORE MONOFASE / SINGLE PHASE MOTOR									
SMM	56	3	4	0.12 kW	B14	230 V	50 Hz	TEFC	T1
Tipo Type	Grandezza Size	Indicativo potenza Power coefficient	Poli Poles	Potenza Power	Forma costruttiva Version	Tensione Voltage	Frequenza Frequency	Ventilazione Fan cooling	Pos. Morsetti Terminal box pos.
<b>SMM</b> 	Vedere tab. See tab.	<b>1-2-3</b>	<b>4</b>	<b>0.04 kW</b> ... <b>0.18 kW</b>	<b>B14</b>	<b>230V</b>	<b>50Hz</b>	<b>TEFC</b>  <b>TENV</b>	<b>T1 (Std)</b>  <b>T4</b> <b>T2</b> <b>T3</b>

## Versioni

## Versions

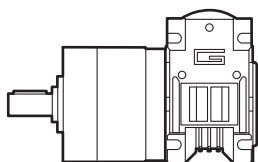

US

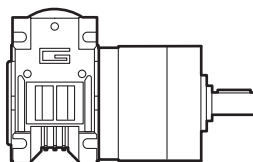

UD

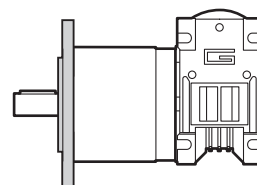

CS

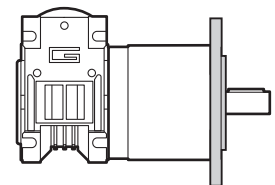

CD

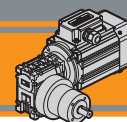

**Simbologia**
**Symbols**

$n_1$ [min <sup>-1</sup> ]	Velocità in ingresso / <i>Input speed</i>	$sf$	Fattore di servizio / <i>Service factor</i>
$n_2$ [min <sup>-1</sup> ]	Velocità in uscita / <i>Output speed</i>	Rd %	Rendimento dinamico / <i>Dynamic efficiency</i>
$i$	Rapporto di riduzione / <i>Ratio</i>	$A_2$ [N]	Carico assiale ammissibile in uscita / <i>Permitted output axial load</i>
$P_1$ [kW]	Potenza in entrata / <i>Input power</i>	$R_2$ [N]	Carico radiale ammissibile in uscita / <i>Permitted output radial load</i>
$M_2$ [Nm]	Coppia in uscita in funzione di $P_1$ / <i>Output torque referred to <math>P_1</math></i>		

**Lubrificazione**
**Lubrication**

I riduttori epicicloidali sono lubrificati in modo permanente, non richiedono quindi ulteriore manutenzione.  
Questo gli consente di essere installati praticamente ovunque.

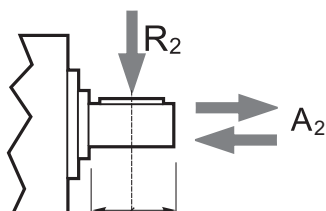
*Planetary gearboxes are life-time lubricated with grease, therefore they are maintenance free.  
They can be installed in any location.*

**Carichi radiali**
**Radial loads**

Numero di stadi <i>Stages number</i>	Carichi Radiali $R_2$ [N] / <i>Radial Load <math>R_2</math> [N]</i>	
	PM52	PM62
1	200	240
2	320	360
3	450	520

Numero di stadi <i>Stages number</i>	Carichi Assiali $A_2$ [N] / <i>Axial Load <math>A_2</math> [N]</i>	
	PM52	PM62
1	60	70
2	100	100
3	150	150



**Rapporti**
**Ratios**

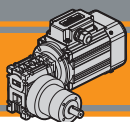

Motoriduttore <i>Gearmotor</i>	Numero stadi epicicloidale <i>Planetary stages number</i>	Rapporto epicicloidale <i>Planetary ratio</i>	Rapporto vite senza fine <i>Wormgearbox ratio</i>	Rapporto finale <i>Total ratio</i>
WMP 026/052 WMP 026/062	1	6.75	10	67.5
			15	101.3
			20	135
			30	202.5
			40	270
			50	337.5
	2	25.01	10	250.1
			15	375.15
			20	500.2
			30	750.3
			40	1000.4
			50	1250.5
			60	1500.6
	45.56	60	2734	



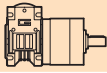

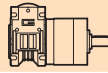

**Dati tecnici**

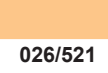

**Technical data**

P <sub>1</sub> [kW]	n <sub>2</sub> [min <sup>-1</sup> ]	M <sub>2</sub> [Nm]	sf	i		
<b>0.04</b>						
SMT5014	20.7	12.2	2.0	67.5	<b>026/521</b>	
SMM5014	13.8	17.2	1.4	101.3		
(1400 min <sup>-1</sup> )	10.4	21.8	1.1	135		
	6.9	25.0	1.0	202.5		
	5.2	25.0	1.0	270		
	4.1	25.0	1.0	337.5		
	3.5	25.0	1.0	405		
	5.6	25.0	1.0	250.1		<b>026/522</b>
	3.7	25.0	1.0	375.15		
	2.8	25.0	1.0	500.2		
	1.9	25.0	1.0	750.3		
	1.4	25.0	1.0	1000.4		
	1.1	25.0	1.0	1250.5		
	0.9	25.0	1.0	1500.6		
	0.5	25.0	1.0	2734		
	20.7	12.2	3.3	67.5	<b>026/621</b>	
	13.8	17.2	2.3	101.3		
	10.4	21.8	1.8	135		
	6.9	29.2	1.4	202.5		
	5.2	36.0	1.1	270		
	4.1	40.0	1.0	337.5		
	3.5	40.0	1.0	405		
	5.6	42.5	1.2	250.1		<b>026/622</b>
	3.7	50.0	1.0	375.15		
	2.8	50.0	1.0	500.2		
	1.9	50.0	1.0	750.3		
	1.4	50.0	1.0	1000.4		
	1.1	50.0	1.0	1250.5		
	0.9	50.0	1.0	1500.6		
	0.5	50.0	1.0	2734		

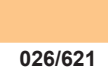
P <sub>1</sub> [kW]	n <sub>2</sub> [min <sup>-1</sup> ]	M <sub>2</sub> [Nm]	sf	i	
<b>0.06</b>					
SMT5024	20.7	18.3	1.4	67.5	<b>026/521</b>
SMM5024	13.8	25.0	1.0	101.3	
(1400 min <sup>-1</sup> )	10.4	25.0	1.0	135	
	20.7	18.3	2.2	67.5	<b>026/621</b>
	13.8	25.9	1.5	101.3	
	10.4	32.7	1.2	135	
	6.9	40.0	1.0	202.5	
	5.2	40.0	1.0	270	
	5.6	50.0	1.0	250.1	

P <sub>1</sub> [kW]	n <sub>2</sub> [min <sup>-1</sup> ]	M <sub>2</sub> [Nm]	sf	i	
<b>0.09</b>					
SMT5034	20.7	25.0	1.0	67.5	<b>026/521</b>
SMM5034	13.8	27.5	1.5	67.5	
SMT5624	20.7	27.5	1.5	67.5	<b>026/621</b>
SMM5624	13.8	38.8	1.0	101.3	
(1400 min <sup>-1</sup> )	10.4	40.0	1.0	135	
					

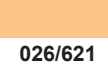
P <sub>1</sub> [kW]	n <sub>2</sub> [min <sup>-1</sup> ]	M <sub>2</sub> [Nm]	sf	i	
<b>0.12</b>					
SMT5044	20.7	36.7	1.1	67.5	<b>026/621</b>
SMT5634	13.8	40.0	1.0	101.3	
SMM5634	13.8	40.0	1.0	101.3	<b>026/622</b>
(1400 min <sup>-1</sup> )					
					

P <sub>1</sub> [kW]	n <sub>2</sub> [min <sup>-1</sup> ]	M <sub>2</sub> [Nm]	sf	i	
<b>0.18</b>					
SMT5644	20.7	40.0	1.0	67.5	<b>026/621</b>
SMM5644	13.8	40.0	1.0	101.3	
(1400 min <sup>-1</sup> )					
					

N.B.  
Verificare sempre che la coppia M<sub>2</sub> utilizzata non ecceda il valore indicato nelle caselle in grigio.

N.B.  
Please check that the output torque M<sub>2</sub> does not exceed the value in the grey areas.



Motori Motors	SMT			SMM		
	5014 5024 5034 5044	5624 5634	6324	5024 5034	5624 5634	6324
IEC	56 B14			56 B14		

**Dati tecnici elettrici**

**Electrical technical data**



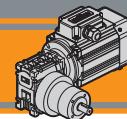

Motori applicabili

IEC Motor adapters

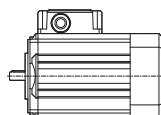

		SMT		SMM	
		5014	5624	5014	5624
		5024	5634	5024	5634
		5034	5644	5034	5644
		5044	5654		
WMP	026/52	67.5 - 2734		67.5 - 2734	
	026/62	67.5 - 2734		67.5 - 2734	

67.5 - 2734

Rapporti di riduzione i  
Ratio i

Dimensioni

Dimensions

WMP 026/521  
WMP 026/522

SMT50...TEFC  
SMM50... TEFC

SMT50...TENV  
SMM50... TENV

S3 servizio 30%  
duty

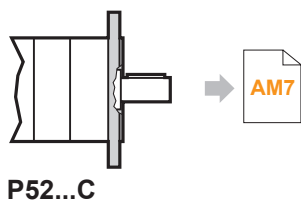
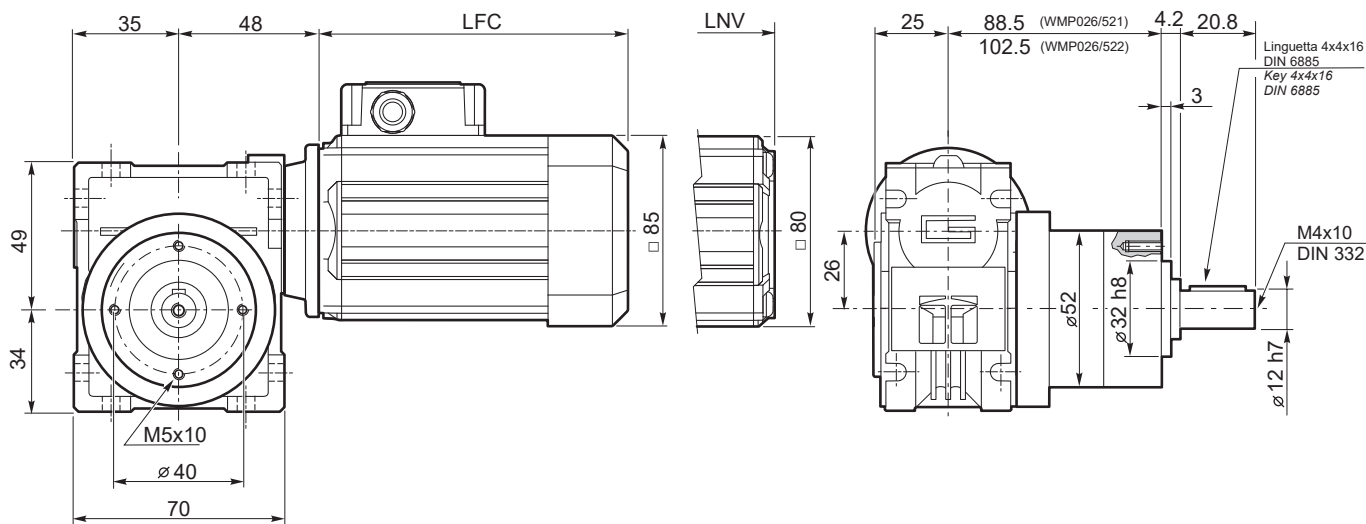

SMT	LFC	LNV	Kg	
5014	135.5	108.5	4.1	
5024	150.5	123.5	4.5	
5034	175.5	148.5	5.3	
5044	200.5	173.5	6	

SMM	LFC	LNV	Kg	
5014	150.5	123.5	4.5	
5024	175.5	148.5	5.3	
5034	200.5	173.5	6	

Nota: il condensatore sarà fornito a corredo  
Note: the capacitor will be supplied separately

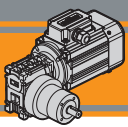

**Dimensioni**

**Dimensions**

**WMP 026/521**  
**WMP 026/522**

**SMT56...TEFC**  
**SMM56... TEFC**

**SMT56...TENV**  
**SMM56... TENV** S3 servizio duty 30%

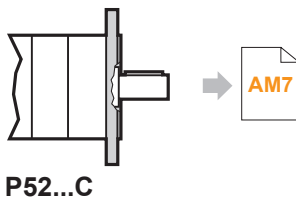
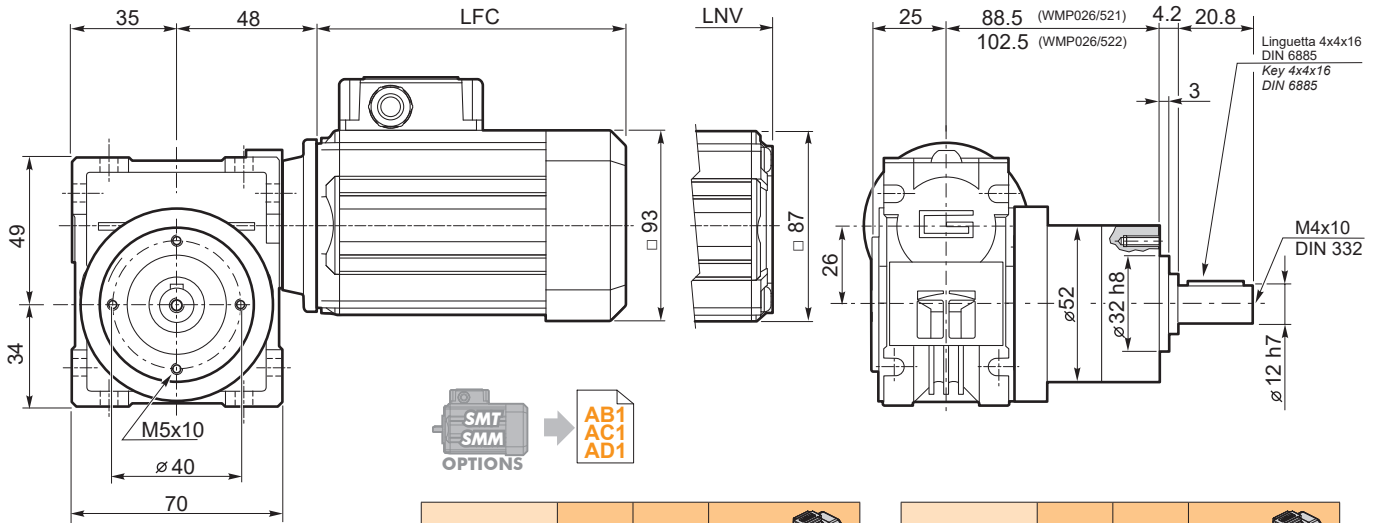

**P52...C**

SMT	LFC	LNV	Kg	
5624	141	117	4.6	
5634	151	127	5	
5644	186	162	6.2	
5654	206	182	6.9	

SMM	LFC	LNV	Kg	
5624	151	127	4.9	
5634	171	147	5.5	
5644	206	182	6.8	

**Nota:** il condensatore sarà fornito a corredo  
**Note:** the capacitor will be supplied separately

**WMP 026/621**  
**WMP 026/622**

**SMT50...TEFC**  
**SMM50... TEFC**

**SMT50...TENV**  
**SMM50... TENV** S3 servizio duty 30%

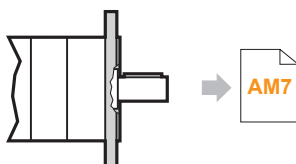
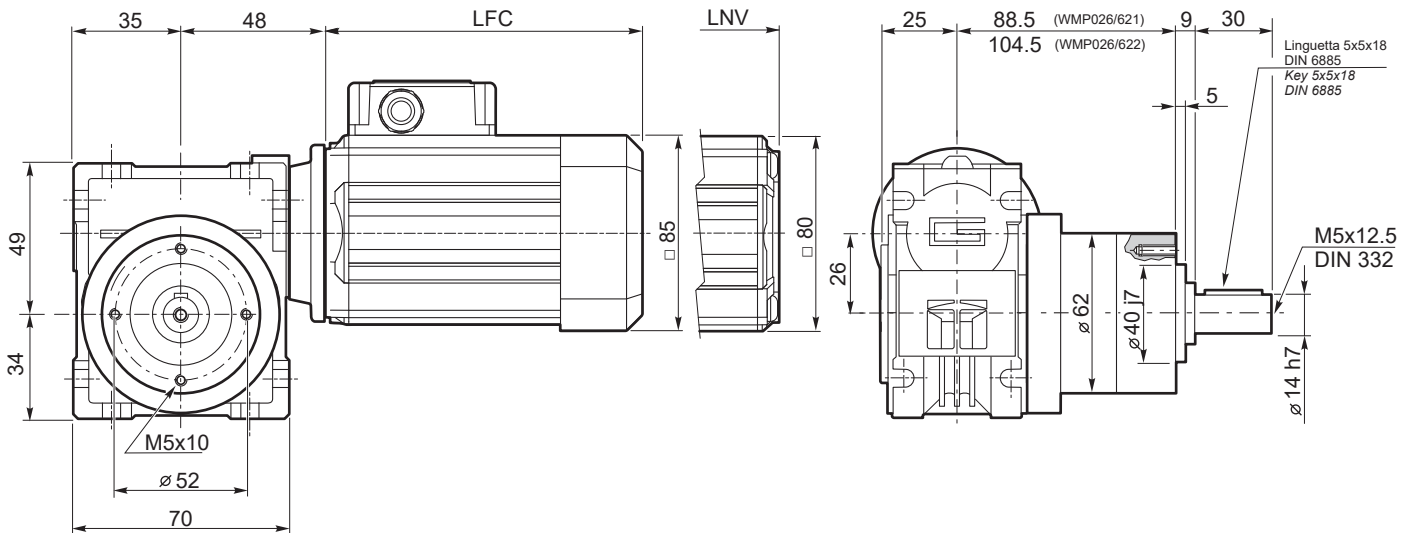

**P62...C**

SMT	LFC	LNV	Kg	
5014	135.5	108.5	4.4	
5024	150.5	123.5	4.8	
5034	175.5	148.5	5.6	
5044	200.5	173.5	6.3	

SMM	LFC	LNV	Kg	
5014	150.5	123.5	4.8	
5024	175.5	148.5	5.6	
5034	200.5	173.5	6.3	

**Nota:** il condensatore sarà fornito a corredo  
**Note:** the capacitor will be supplied separately

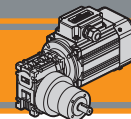

Dimensioni

Dimensions

WMP 026/621  
WMP 026/622

SMT56...TEFC  
SMM56... TEFC

SMT56...TENV  
SMM56... TENV

S3 servizio 30%  
duty

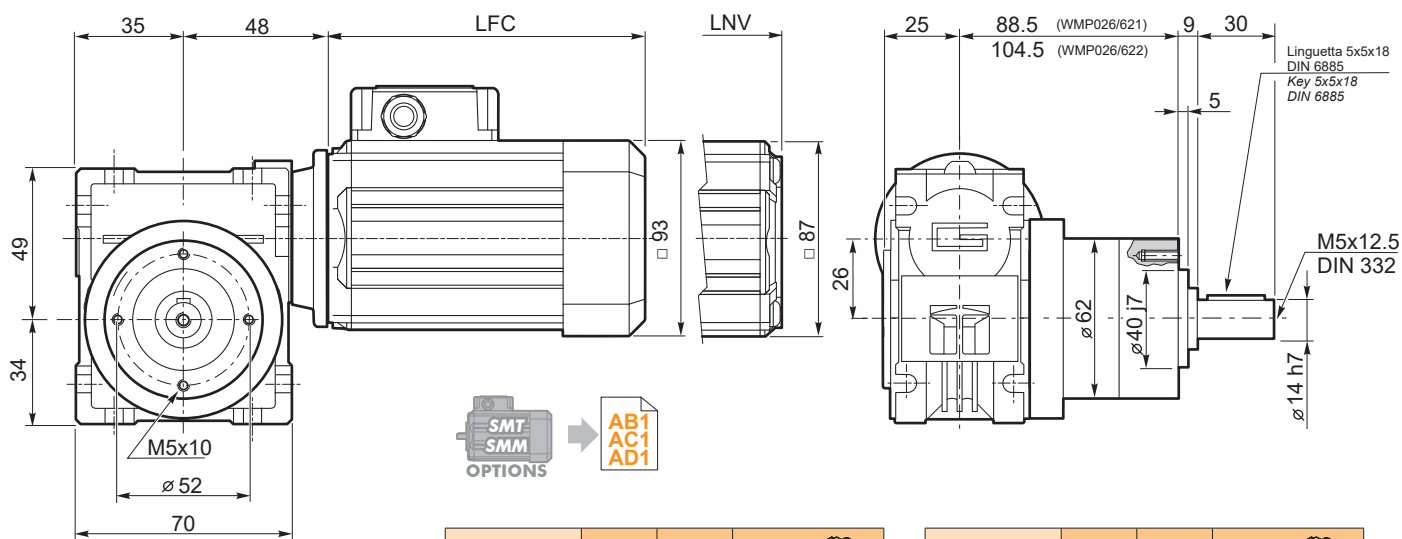

SMT	LFC	LNV	Kg	
5624	141	117	4.9	
5634	151	127	5.3	
5644	186	162	6.5	
5654	206	182	7.2	

SMM	LFC	LNV	Kg	
5624	151	127	5.2	
5634	171	147	5.8	
5644	206	182	7.1	

Nota: il condensatore sarà fornito a corredo  
Note: the capacitor will be supplied separately

P.../... C... Flange uscita / Output flanges

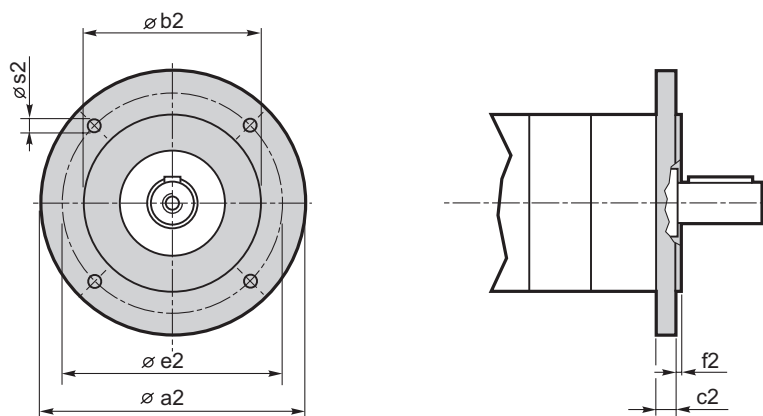

Dimensioni / Dimensions							
P	a2	b2	c2	e2	f2	s2	Flangia uscita Output flange
52	80	50 j7	9	65	2.5	M5	C80
	90	60 j7	9	75	2.5	5.5	C90
	105	70 j7	9	85	2.5	6.5	C105
	120	80 j7	9	100	3.0	6.5	C120
62	80	50 j7	9	65	2.5	M5	C80
	90	60 j7	9	75	2.5	5.5	C90
	105	70 j7	9	85	2.5	6.5	C105
	120	80 j7	9	100	3.0	6.5	C120



 **TRANSTECNO SRL**  
**HEADQUARTERS**

Company subject to the management  
and coordination of INTERPUMP GROUP SPA  
Via Caduti di Sabbiano, 11  
40011 Anzola dell'Emilia (BO)  
ITALY  
T +39 051 64 25 811  
F +39 051 73 49 43  
sales@transtecno.com  
www.transtecno.com

**TRANSTECNO®**  
the modular gearmotor

MEMBER OF INTERPUMP GROUP



**HANGZHOU INTERPUMP  
POWER TRANSMISSIONS CO LTD**  
No.4 Xiuyan Road Fengdu Industry Zone  
Pingyao Town Yuhang District  
Hangzhou City, Zhejiang Province  
311115 – CHINA  
T +86 571 86 92 02 60  
info-china@transtecno.cn  
www.transtecno.cn



**TRANSTECNO IBÉRICA  
THE MODULAR GEARMOTOR, S.A.**  
Carrer de la Ciència, 45  
08840 Viladecans (Barcelona) - SPAIN  
T +34 931 598 950  
info@transtecno.es  
www.transtecno.es



**TRANSTECNO B.V.**  
Siliciumweg 32  
3812 SX Amersfoort - NETHERLANDS  
T +31(0) 33 45 19 505  
info@transtecno.nl  
www.transtecno.nl



**TRANSTECNO AANDRIJFTECHNIEK B.V.**  
Siliciumweg 32  
3812 SX Amersfoort - NETHERLANDS  
T +31 (0) 33 20 4 7 006  
info@transtecnoaandrijftechnik.nl  
www.transtecnoaandrijftechnik.nl



**MA TRANSTECNO S.A.P.I. DE C.V.**  
Julián Sepúlveda Dávila #107,  
Parque Industrial SG  
Apodaca, Nuevo León, CP. 66640  
MÉXICO  
T +52 8113340920  
info@transtecno.com.mx  
www.transtecno.com.mx



**TRANSTECNO USA**  
8 Creek Parkway,  
Boothwyn PA 19061-8136 - UNITED STATES  
T + 1 (610) 4970154

**TRANSTECNO USA – WEST COAST BRANCH**  
14561 Fryelands Blvd SE  
Monroe, WA 98272 - UNITED STATES  
T +1 360-863-1300  
usaoffice@transtecno.com  
www.transtecno.com



**TRANSTECNO CANADA**  
51 B Caldari Road Unit 10  
Vaughan, ON L4K 4G3 - CANADA  
T +1 905 761 0762  
canadaoffice@transtecno.com  
www.transtecno.com



**TRANSTECNO INDIA**  
#6A, Sipcot Industrial complex, Phase-1, Elasangiri Road  
Hosur – 635126 Tamilnadu - INDIA  
T +91 4344 274434  
M +91 81443 88800



**TRANSTECNO BRAZIL**  
Rua Gilberto de Zorzi, 525 Forqueta - CEP. 95115-730  
CX Postal 3544 Caxias do Sul RS – BRAZIL

**TRANSTECNO BRAZIL – SÃO PAULO BRANCH**  
Rua Fortunato Jose Deltreggia, 745 – CEP: 13347-441  
Indaiatuba, São Paulo – BRAZIL  
T +55 19 98927 3906

**TRANSTECNO BRAZIL – PORTO ALEGRE BRANCH**  
Rua Dr. Freire Alemão 155 / 402 - CEP. 90450-060  
Auxiliadora Porto Alegre RS - BRAZIL  
T +55 51 4042 0916  
M +55 51 811 45 962  
braziloffice@transtecno.com  
www.transtecno.com.br



**INTERPUMP ANTRIEBSTECHNIK GMBH**  
Büro Stuttgart - Dieselstraße 6  
70738 Fellbach - GERMANY  
T +49 (0)171 4781909  
germanoffice@transtecno.com  
www.transtecno.com



**TRANSTECNO AUSTRALIA**  
1/2 Access Way, CarrumDowns, Victoria, 3201  
AUSTRALIA  
T +61 (03) 9775 1077  
australiaoffice@transtecno.com  
www.transtecno.com



**SALES OFFICE OCEANIA**  
Unit 5, 12 Nyholt Drive, Yatala 4207  
Queensland - AUSTRALIA  
T +61 07 3800 0103  
M +61 04 38060997  
oceaniaoffice@transtecno.com  
www.transtecno.com.au