

MINI  **TECNO**™
small but strong

Ott Antriebstechnik
Standardisierte Individualität

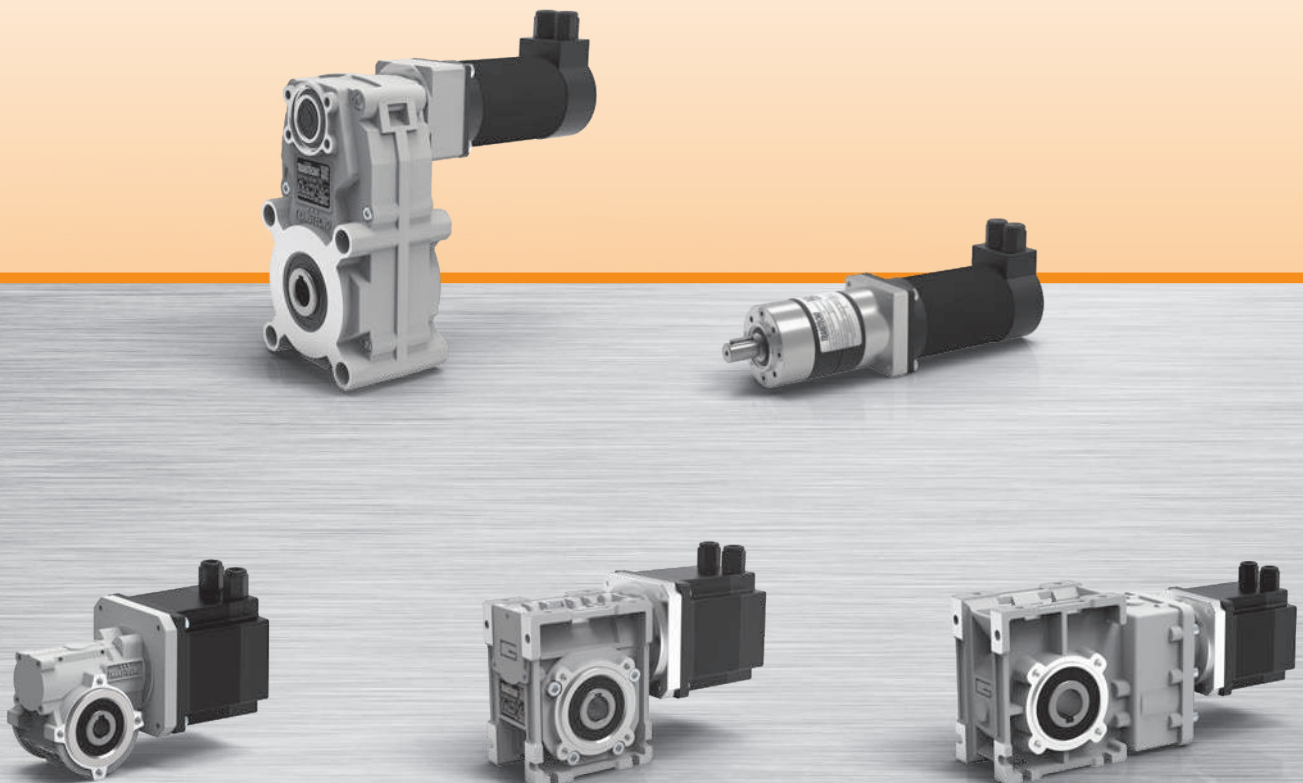









BLDC - Getriebemotoren
BLDC - Motorsteuerungen



MINI  **TECNO**™ brand of
TRANSTECNO®

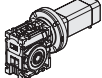

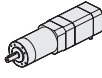
BLDC

	Indice	Index	Pag. Page
 	C-A Motori brushless CC BL	Brushless DC motors BL	C-A1
 	C-B Motoriduttori brushless CC ad assi ortogonali BLCMB	Brushless DC helical bevel gearmotors BLCMB	C-B1
 	C-C Motoriduttori brushless CC pendolari BLFT	Brushless DC helical parallel gearmotors BLFT	C-C1
 	C-D Motoriduttori brushless CC a vite senza fine BLCM	Brushless DC wormgearmotors BLCM	C-D1
 	C-E Motoriduttori brushless CC epicicloidali BLP	Brushless DC planetary gearmotors BLP	C-E1
 	C-F Azionamenti per motori brushless CC BLD	Brushless DC motor controls BLD	C-F1

Questo catalogo annulla e sostituisce ogni precedente edizione o revisione.
 Ci riserviamo inoltre il diritto di apportare modifiche senza preavviso.
 La versione più aggiornata è disponibile sul sito
www.transtecno.com

*This catalogue supersedes any previous edition and revision.
 We reserve the right to implement modifications without notice.
 The most updated version is available on our website
www.transtecno.com*

MINI  **TECNO**™
small but strong

BL



Motori brushless CC
Brushless DC motors

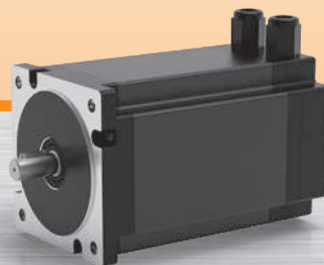
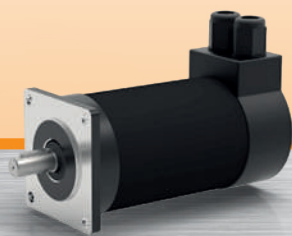

MINI  **TECNO**™ brand of
TRANSTECNO®



BLDC

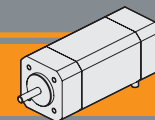

	Indice	Index	Pag. Page
	Caratteristiche tecniche	<i>Technical features</i>	CA2
	Grado di protezione IP	<i>IP enclosures protection indexes</i>	CA2
	Classe di isolamento termico	<i>Insulation class</i>	CA2
	Tipi di servizio IEC	<i>IEC duty cycle ratings</i>	CA2
	Legenda / Glossario dei grafici	<i>Key / Diagram Glossary</i>	CA3
	Formule utili	<i>Useful formulas</i>	CA3
BLS022.240	Specifiche costruttive	<i>General features</i>	CA4
	Prestazioni	<i>Performances</i>	CA4
	Dimensioni	<i>Dimensions</i>	CA5
	Diagramma dei collegamenti	<i>Connection diagram</i>	CA5
BLS043.240	Specifiche costruttive	<i>General features</i>	CA6
	Prestazioni	<i>Performances</i>	CA6
	Dimensioni	<i>Dimensions</i>	CA7
	Diagramma dei collegamenti	<i>Connection diagram</i>	CA7
BL070.240 BL070.24B	Specifiche costruttive	<i>General features</i>	CA8
	Prestazioni	<i>Performances</i>	CA8
	Dimensioni	<i>Dimensions</i>	CA9
	Diagramma dei collegamenti	<i>Connection diagram</i>	CA9
BL070.480 BL070.48B	Specifiche costruttive	<i>General features</i>	CA10
	Prestazioni	<i>Performances</i>	CA10
	Dimensioni	<i>Dimensions</i>	CA11
	Diagramma dei collegamenti	<i>Connection diagram</i>	CA11
BL140.480	Specifiche costruttive	<i>General features</i>	CA12
	Prestazioni	<i>Performances</i>	CA12
	Dimensioni	<i>Dimensions</i>	CA13
	Diagramma dei collegamenti	<i>Connection diagram</i>	CA13
BL210.480 BL210.48E	Specifiche costruttive	<i>General features</i>	CA14
	Prestazioni	<i>Performances</i>	CA14
	Dimensioni	<i>Dimensions</i>	CA15
	Diagramma dei collegamenti	<i>Connection diagram</i>	CA15
Freno / Brake	Specifiche costruttive	<i>General features</i>	CA16
	Dimensioni	<i>Dimensions</i>	CA16

Questa sezione annulla e sostituisce ogni precedente edizione o revisione. Qualora questa sezione non Vi sia giunta in distribuzione controllata, l'aggiornamento dei dati ivi contenuto non è assicurato. **In tal caso la versione più aggiornata è disponibile sul nostro sito internet www.transtecno.com**

This section replaces any previous edition and revision. If you obtained this catalogue other than through controlled distribution channels, the most up to date content is not guaranteed. In this case the latest version is available on our web site www.transtecno.com

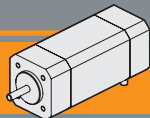

Caratteristiche tecniche

Technical features

I motori brushless CC della serie BL vengono realizzati in 5 taglie con coppie da 0.22 Nm a 2.1 Nm, e sono forniti con driver esterno.

I vantaggi di utilizzare i motori brushless anziché i tradizionali motori cc a spazzole, sono i seguenti:

- Lunga durata nel tempo
- Elevata efficienza
- Commutazione elettronica e controllo del motore tramite sensori digitali (encoder, resolver ecc..)
- Ampio campo di regolazione della velocità
- Mancanza di manutenzione

I motori della serie BL sono estremamente compatti e grazie al basso momento di inerzia offrono una elevata prestazione dinamica, ed inoltre sono economici in quanto dotati di sensori di Hall (anziché encoder o resolver).

Le 3 fasi dell'avvolgimento del motore sono a bassa tensione 24V / 36V / 48V e quindi offrono maggiori garanzie in termini di sicurezza dell'impianto, soprattutto nelle applicazioni dove l'operatore può essere a contatto con il motore stesso.

Tutti i motori sono realizzati con grado di protezione IP55.

Brushless DC motors from the BL range are available in 5 sizes with torque from 0.22 Nm to 2.1 Nm and they are supplied with external driver.

The advantages of using brushless motors instead of traditional DC brushed motors are the following:

- Longer life time
- Higher efficiency
- Electronic commutation and control of the motor via digital sensors (encoder, resolver etc.)
- Wide speed range
- Maintenance free

BL motors have a compact design and thanks to low inertia they have high performances and are a low cost solution already including Hall sensors, as opposed to an encoder or resolver.

The 3 phase windings of the motor have a low voltage of 24/36/48 V and so these motors are safer to use when a machine operator has direct contact with them.

IP55 protection index for all the motors.

Grado di protezione IP

IP enclosures protection indexes

Indica il grado di isolamento meccanico del corpo motore.

1^a cifra protezione alla penetrazione di corpi solidi.

2^a cifra protezione contro la penetrazione d'acqua.

Indicates the degree of mechanical insulation of the motor body. 1st figure indicating level of protection against the penetration of solid bodies.

2nd figure: indicating degree to which the motor is waterproof.

5	Protetto contro la polvere <i>Dust proof</i>	5	Protetto contro i getti d'acqua <i>Water jet proof</i>
----------	---	----------	---

Classe di isolamento termico

Insulation class

Classe / Class	Δt °C Temp. ambiente: 40°C Ambient temperature: 40°C
B	90°C
F	115°C
H	140°C

Tipi di servizio IEC

IEC duty cycle ratings

S1	Servizio continuo. Funzionamento a carico costante per una durata sufficiente al raggiungimento dell'equilibrio termico.	Continuous duty. The motor works at a constant load for enough time to reach temperature equilibrium
S2	Servizio di durata limitata. Funzionamento a carico costante per una durata inferiore a quella necessaria al raggiungimento dell'equilibrio termico, seguito da un periodo di riposo tale da riportare il motore alla temperatura ambiente.	Short time duty. The motor works at a constant load, but not long enough to reach temperature equilibrium, and the rest periods are long enough for the motor to reach ambient temperature.
S3	Servizio periodico intermittente. Sequenze di cicli identici di marcia e di riposo a carico costante, senza raggiungimento dell'equilibrio termico. La corrente di spunto ha effetti trascurabili sul surriscaldamento del motore.	Intermittent periodic duty. Sequential, identical run and rest cycles with constant load. Temperature equilibrium is never reached. Starting current has little effect on temperature rise.

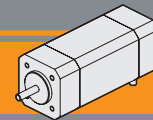

Legenda / Glossario dei grafici

Key / Diagram Glossary

Dato un motore brushless CC, la velocità di rotazione è funzione lineare della coppia; così pure la corrente assorbita è una funzione lineare della coppia. Velocità e corrente variano in maniera sensibile al variare del carico.

With a brushless DC motor, the rotational speed is a linear function of the torque. In the same way, the absorbed current is also a linear function of the torque. Speed and current change a lot against applied torque.

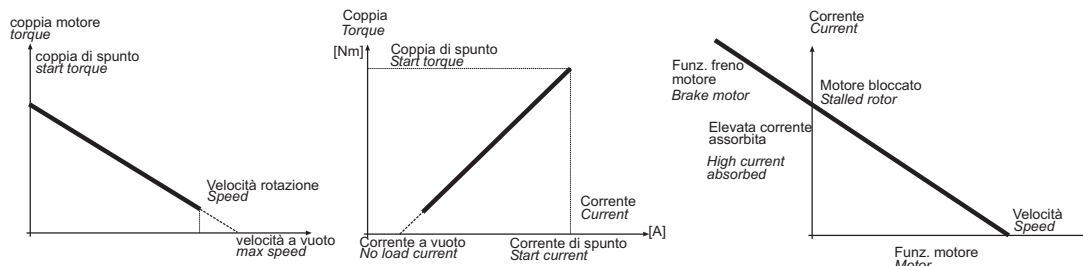

La potenza utile (potenza all' albero) si ricava dalla formula:

$$P_n [W] = M_n \cdot S = \frac{2\pi}{60} \cdot n_1 \cdot M_n$$

The output power is calculated using the formula:

$$P_n [W] = M_n \cdot S = \frac{2\pi}{60} \cdot n_1 \cdot M_n$$

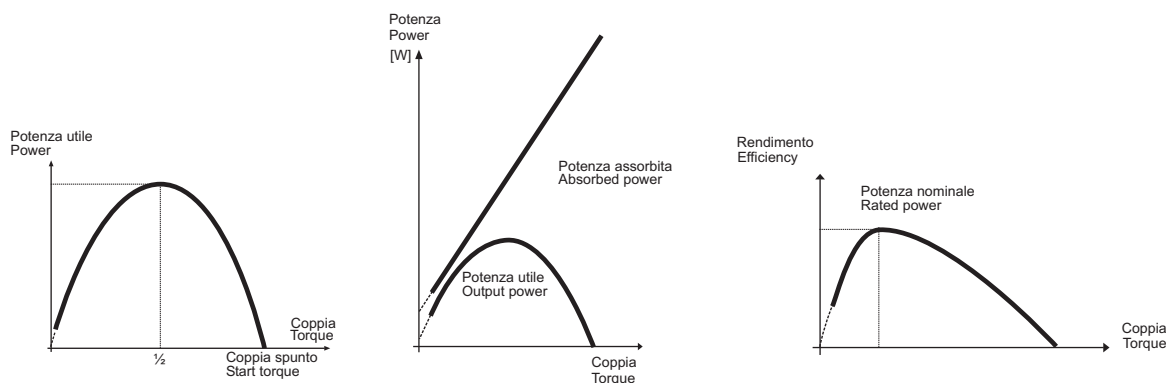

Poiché la tensione di alimentazione è costante mentre la corrente è linearmente crescente al crescere della coppia, l'andamento della potenza assorbita è una retta crescente. Dal rapporto tra la potenza meccanica e la potenza assorbita si ottiene il grafico dell'efficienza.

Since the supply voltage is constant, whereas the current increases in a linear manner as the torque increases, the absorbed power trend is a straight line going up. Efficiency is shown from the ratio between the output power and the absorbed power.

Formule utili

Useful formulas

$$\eta = \frac{P_n}{P_a}$$

$$P_a = V \cdot I$$

$$P_n = V \cdot I \cdot \eta$$

$$P_n = M_n \cdot S_v$$

$$S_v = \frac{n_1}{9.55}$$

$$\eta = \frac{P_n}{P_a}$$

$$P_a = V \cdot I$$

$$P_n = V \cdot I \cdot \eta$$

$$P_n = M_n \cdot S_v$$

$$S_v = \frac{n_1}{9.55}$$

[HP] · 746 = [W].
Esempio 2 HP = circa 1500 W.

[HP] · 746 = [W].
Example 2 HP = approx. 1500 W.

S	—	Servizio	<i>Duty</i>
P_n	[W]	Potenza in uscita	<i>Rated power</i>
P_a	[W]	Potenza assorbita	<i>Absorbed power</i>
M_n	[Nm]	Coppia nominale	<i>Rated torque</i>
V	[V]	Tensione	<i>Voltage</i>
I	[A]	Corrente assorbita	<i>Absorbed current</i>
n₁	[min ⁻¹]	Numero giri motore	<i>Motor speed</i>
S_v	[rad/s]	Velocità angolare	<i>Angular speed</i>
IC	—	Classe d'isolamento termico	<i>Thermal insulation class</i>
FF	—	Fattore di forma	<i>Form factor</i>
IP	—	Classe di protezione	<i>protection class</i>
η	—	Rendimento	<i>Efficiency</i>
Kg	—	Massa	<i>Mass</i>

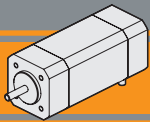

BLS022.240

Specifiche costruttive

General features

Tipologia di avvolgimento <i>Winding type</i>	delta	Max forza radiale <i>Max radial force</i>	75N @ 20 mm dalla flangia 75N @ 20 mm from flange
Angolo sensori Hall <i>HALL effect angle</i>	120 gradi elettrici 120 degree electrical angle	Max forza assiale <i>Max axial force</i>	15N
Gioco radiale <i>Radial play</i>	0.025 mm @ 460 g	Classe di isolamento termico <i>Insulation class</i>	Classe B Class B
Gioco assiale <i>End play</i>	0.025 mm @ 4000 g	Isolamento dielettrico <i>Dielectric strength</i>	500Vcc x 1 minuto 500 Vdc 1 minute
Scantatura albero <i>Shaft run out</i>	0.025 mm	Resistenza isolamento <i>Insulation resistance</i>	100MΩ minimo, 500Vcc 100MΩ min, 500 Vdc

Modello <i>Model</i>	Poli <i>Poles</i>	Fasi <i>Phases</i>	Tensione nominale	Velocità nominale	Coppia nominale	Potenza nominale	Coppia di picco	Corrente nominale	Corrente di picco	Resistenza fase-fase	Induttanza fase-fase	Costante di coppia	Costante FCEM	Inerzia rotore	Peso	IP
			<i>Rated voltage</i>	<i>Rated speed</i>	<i>Rated torque</i>	<i>Rated power</i>	<i>Peak torque</i>	<i>Rated current</i>	<i>Peak current</i>	<i>Line to line resistance</i>	<i>Line to line inductance</i>	<i>Torque constant</i>	<i>Back EMF</i>	<i>Rotor inertia</i>	<i>Weight</i>	
			[V]	[min ⁻¹]	[Nm]	[W]	[Nm]	[A]	[A]	[Ω]	[mH]	[Nm/A]	[V/kRPM]	[gcm ²]	[kg]	
BLS022.240	4	3	36	4000	0.22	92	0.66	3.7	11.2	0.64	2.1	0.06	6.28	119	0.72	55
BLS022.240	4	3	24	3000	0.22	70	0.66	3.7	11.2	0.64	3.1	0.06	6.28	119	0.72	55



Prestazioni

Performances

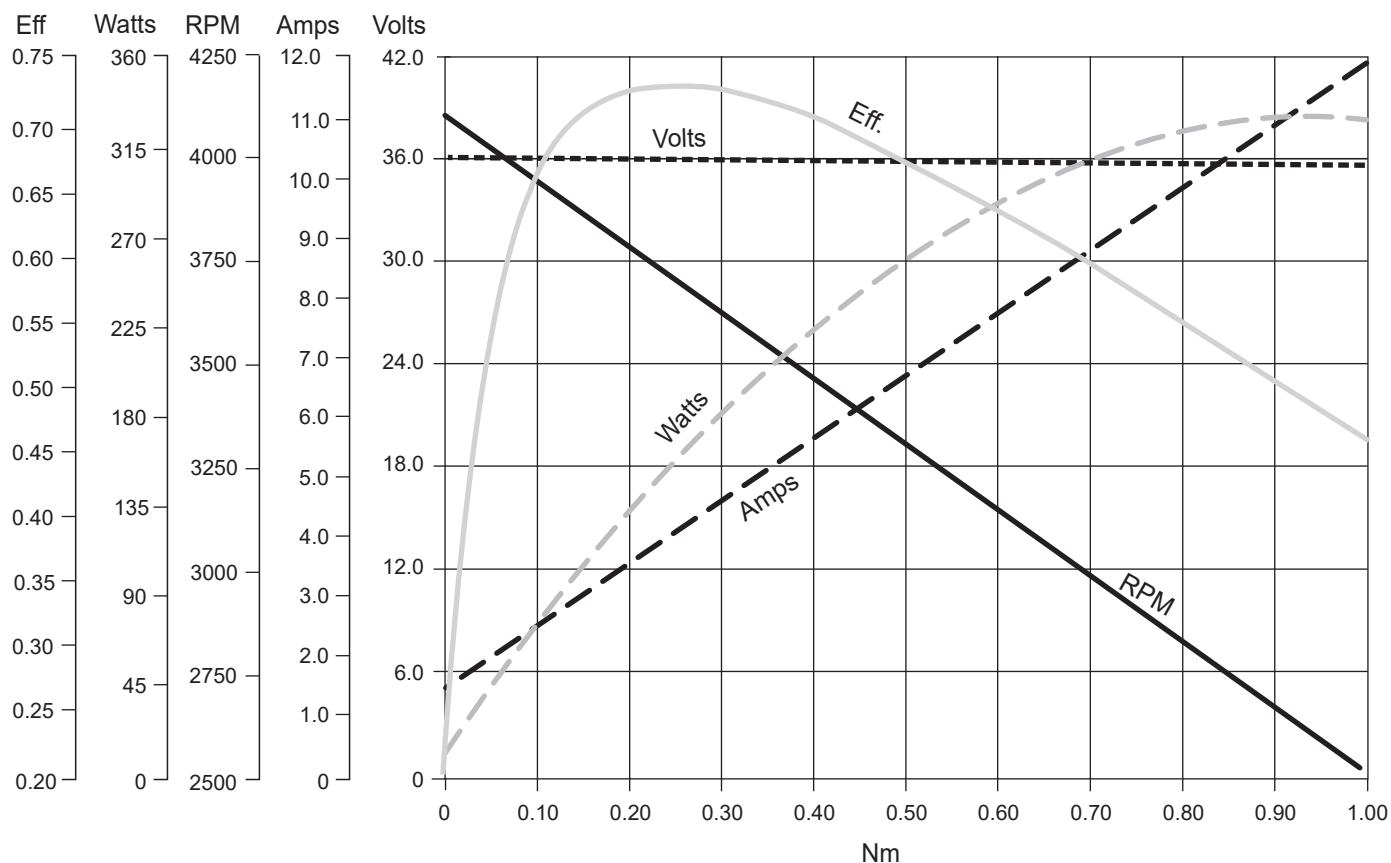

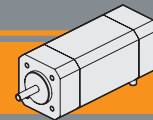
BLS022.240
Dimensioni
Dimensions
BLS022.240

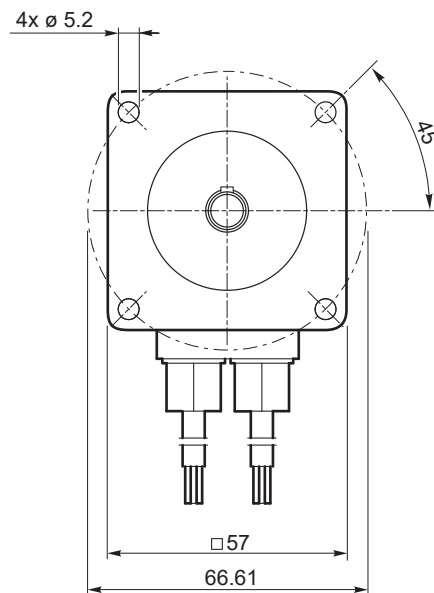
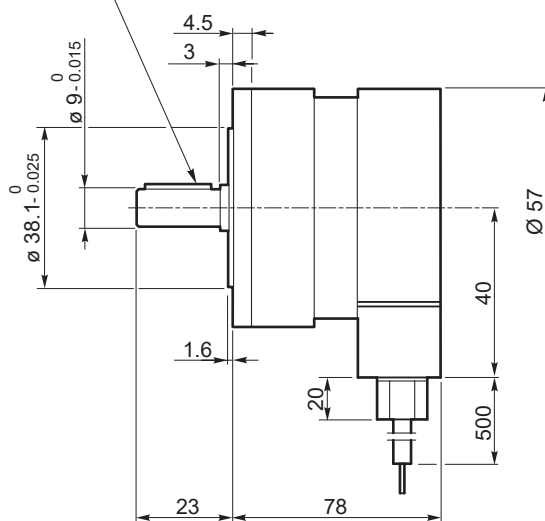
 Linguetta 3x3x16
 DIN 6885
 Key 3x3x16
 DIN 6885

Diagramma dei collegamenti
Connection diagram

Cavi di potenza Power leads	Descrizione Description
Giallo / Yellow	Fase U / U motor Phase
Rosso / Red	Fase V / V motor Phase
Nero / Black	Fase W / W motor Phase

Nota: Si raccomanda di seguire fedelmente gli schemi di collegamento qui riportati, pericolo di danneggiamento del motore o dell'elettronica.

Note: Pls, follow strictly the above connection diagrams, danger for the motor and the electric control

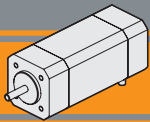
Cavi di segnale Signal leads	Descrizione Description
Blue	HALL fase U U phase HALL
Verde Green	HALL fase V V phase HALL
Bianco White	HALL fase W W phase HALL
Rosso (piccolo) Red (small)	Alimentazione HALL + 5Vcc ÷ + 24 Vcc Supply voltage for Hall sensors, + 5 Vdc ÷ + 24 Vdc
Nero (piccolo) Black (small)	Comune per i segnali di HALL Ground for HALL sensors



BLS043.240

Specifiche costruttive

General features

Tipologia di avvolgimento <i>Winding type</i>	delta
Angolo sensori Hall <i>HALL effect angle</i>	120 gradi elettrici <i>120 degree electrical angle</i>
Gioco radiale <i>Radial play</i>	0.025 mm @ 460 g
Gioco assiale <i>End play</i>	0.025 mm @ 4000 g
Scantatura albero <i>Shaft run out</i>	0.025 mm

Max forza radiale <i>Max radial force</i>	75N @ 20 mm dalla flangia <i>75N @ 20 mm from flange</i>
Max forza assiale <i>Max axial force</i>	15N
Classe di isolamento termico <i>Insulation class</i>	Classe B <i>Class B</i>
Isolamento dielettrico <i>Dielectric strength</i>	500Vcc x 1 minuto <i>500 Vdc 1 minute</i>
Resistenza isolamento <i>Insulation resistance</i>	100MΩ minimo, 500Vcc <i>100MΩ min, 500 Vdc</i>

Modello <i>Model</i>	Poli <i>Poles</i>	Fasi <i>Phases</i>	Tensione nominale	Velocità nominale	Coppia nominale	Potenza nominale	Coppia di picco	Corrente nominale	Corrente di picco	Resistenza fase-fase	Induttanza fase-fase	Costante di coppia	Costante FCEM	Inerzia rotore	Peso	IP
			<i>Rated voltage</i>	<i>Rated speed</i>	<i>Rated torque</i>	<i>Rated power</i>	<i>Peak torque</i>	<i>Rated current</i>	<i>Peak current</i>	<i>Line to line resistance</i>	<i>Line to line inductance</i>	<i>Torque constant</i>	<i>Back EMF</i>	<i>Rotor inertia</i>	<i>Weight</i>	
			[V]	[min ⁻¹]	[Nm]	[W]	[Nm]	[A]	[A]	[Ω]	[mH]	[Nm/A]	[V/kRPM]	[gcm ²]	[kg]	
BLS043.240	4	3	36	4000	0.43	180	1.27	6.8	20.5	0.35	1.0	0.063	6.6	230	1.25	55
BLS043.240	4	3	24	3000	0.43	130	1.27	6.8	20.5	0.35	1.0	0.063	6.6	230	1.25	55



Prestazioni

Performances

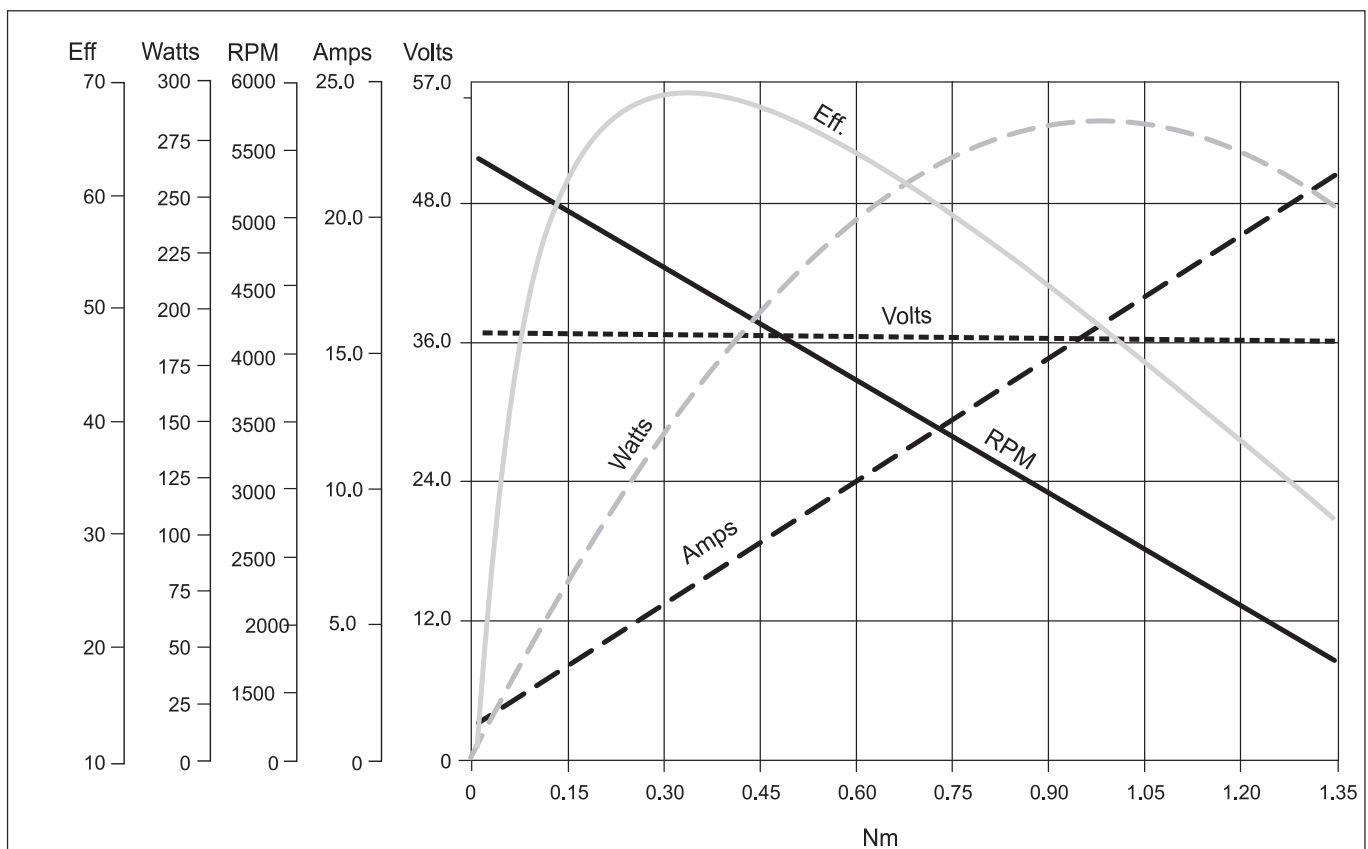

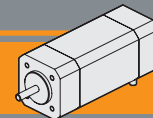
BLS043.240
Dimensioni
Dimensions
BLS043.240

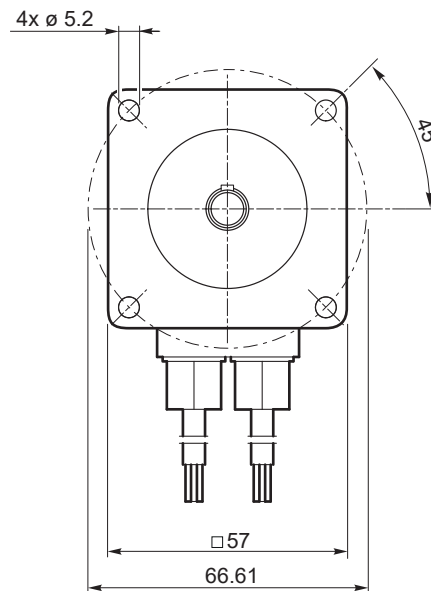
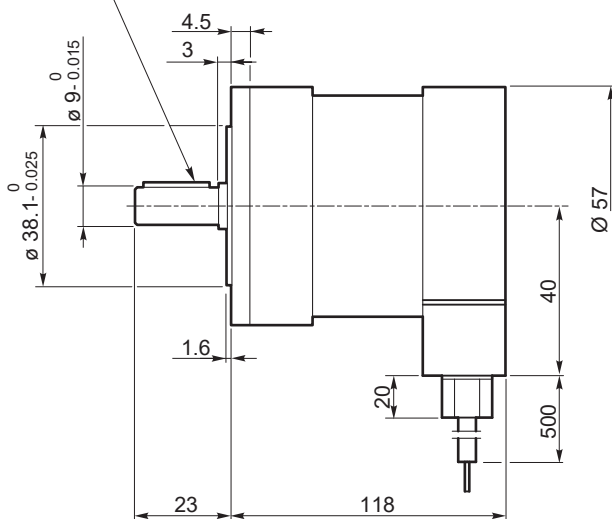
 Linguetta 3x3x16
 DIN 6885
 Key 3x3x16
 DIN 6885

Diagramma dei collegamenti
Connection diagram

Cavi di potenza Power leads	Descrizione Description
Giallo / Yellow	Fase U / U motor Phase
Rosso / Red	Fase V / V motor Phase
Nero / Black	Fase W / W motor Phase

Nota: Si raccomanda di seguire fedelmente gli schemi di collegamento qui riportati, pericolo di danneggiamento del motore o dell'elettronica.

Note: Pls, follow strictly the above connection diagrams, danger for the motor and the electric control

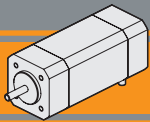
Cavi di segnale Signal leads	Descrizione Description
Blue	HALL fase U U phase HALL
Verde Green	HALL fase V V phase HALL
Bianco White	HALL fase W W phase HALL
Rosso (piccolo) Red (small)	Alimentazione HALL + 5Vcc ÷ + 24 Vcc Supply voltage for Hall sensors, + 5 Vdc ÷ + 24 Vdc
Nero (piccolo) Black (small)	Comune per i segnali di HALL Ground for HALL sensors



BL070.240 / BL070.24B

Specifiche costruttive

General features

Tipologia di avvolgimento <i>Winding type</i>	Stella <i>Star</i>
Angolo sensori Hall <i>HALL effect angle</i>	120 gradi elettrici <i>120 degree electrical angle</i>
Gioco radiale <i>Radial play</i>	0.02 mm @ 450g
Gioco assiale <i>End play</i>	0.08 mm @ 450g
Scantatura albero <i>Shaft run out</i>	0.05 mm

Max forza radiale <i>Max radial force</i>	220N @ 20 mm dalla flangia <i>220N @ 20 mm from flange</i>
Max forza assiale <i>Max axial force</i>	60N
Classe di isolamento termico <i>Insulation class</i>	Classe B <i>Class B</i>
Isolamento dielettrico <i>Dielectric strength</i>	500Vcc x 1 minuto <i>500 Vdc 1 minute</i>
Resistenza isolamento <i>Insulation resistance</i>	100MΩ minimo, 500Vcc <i>100MΩ min, 500 Vdc</i>

Modello <i>Model</i>	Poli <i>Poles</i>	Fasi <i>Phases</i>	Tensione nominale	Velocità nominale	Coppia nominale	Potenza nominale	Coppia di picco	Corrente nominale	Corrente di picco	Resistenza fase-fase	Induttanza fase-fase	Costante di coppia	Costante FCEM	Inerzia rotore	Peso	IP
			<i>Rated voltage</i>	<i>Rated speed</i>	<i>Rated torque</i>	<i>Rated power</i>	<i>Peak torque</i>	<i>Rated current</i>	<i>Peak current</i>	<i>Line to line resistance</i>	<i>Line to line inductance</i>	<i>Torque constant</i>	<i>Back EMF</i>	<i>Rotor inertia</i>	<i>Weight</i>	
			[V]	[min ⁻¹]	[Nm]	[W]	[Nm]	[A]	[A]	[Ω]	[mH]	[Nm/A]	[V/kRPM]	[gcm ²]	[kg]	
BL070.240 BL070.24B	8	3	24	3000	0.7	220	2.1	13	39	0.091	0.23	0.0589	4.24	800	2.1	55



Prestazioni

Performances

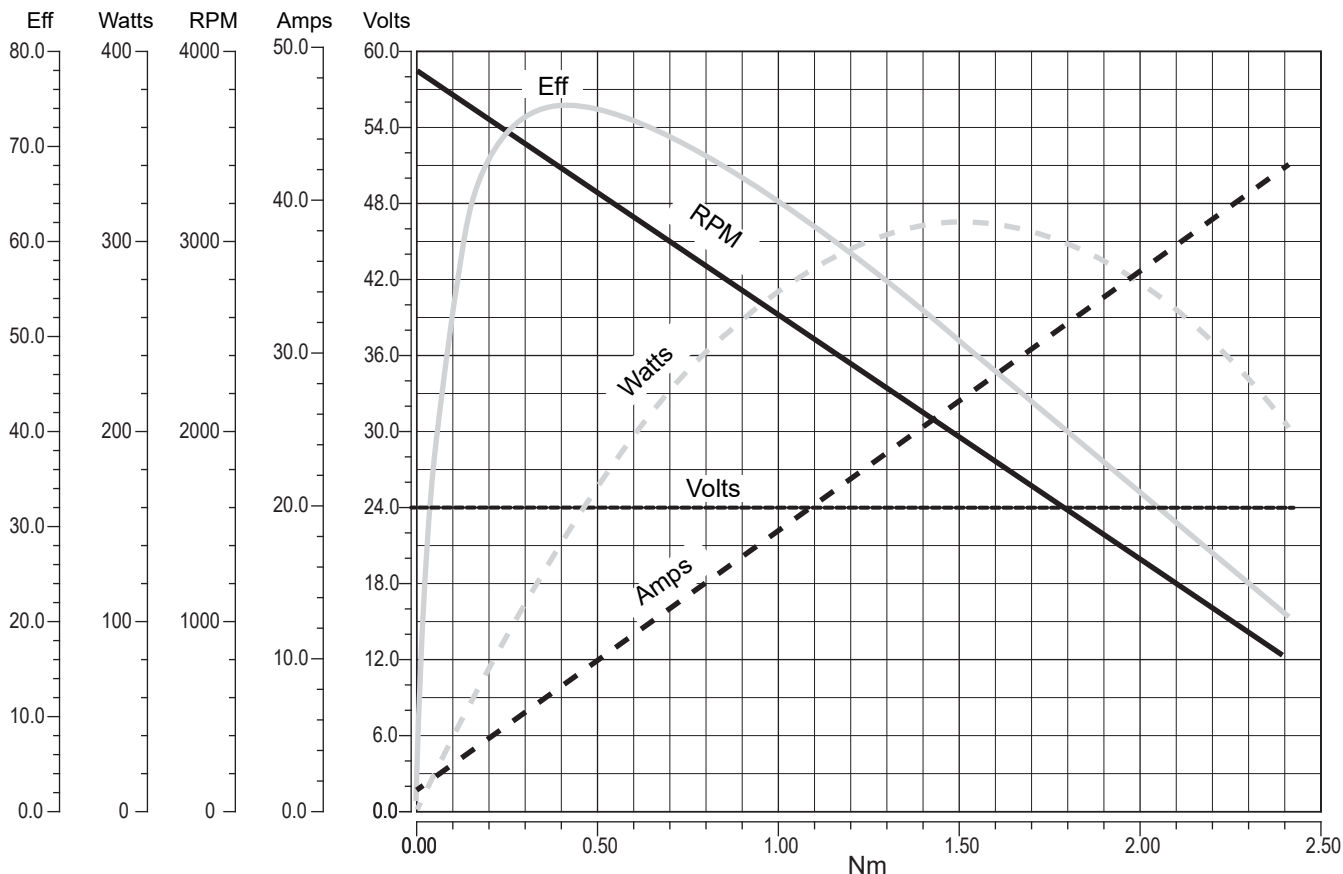

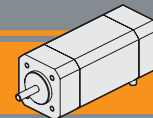
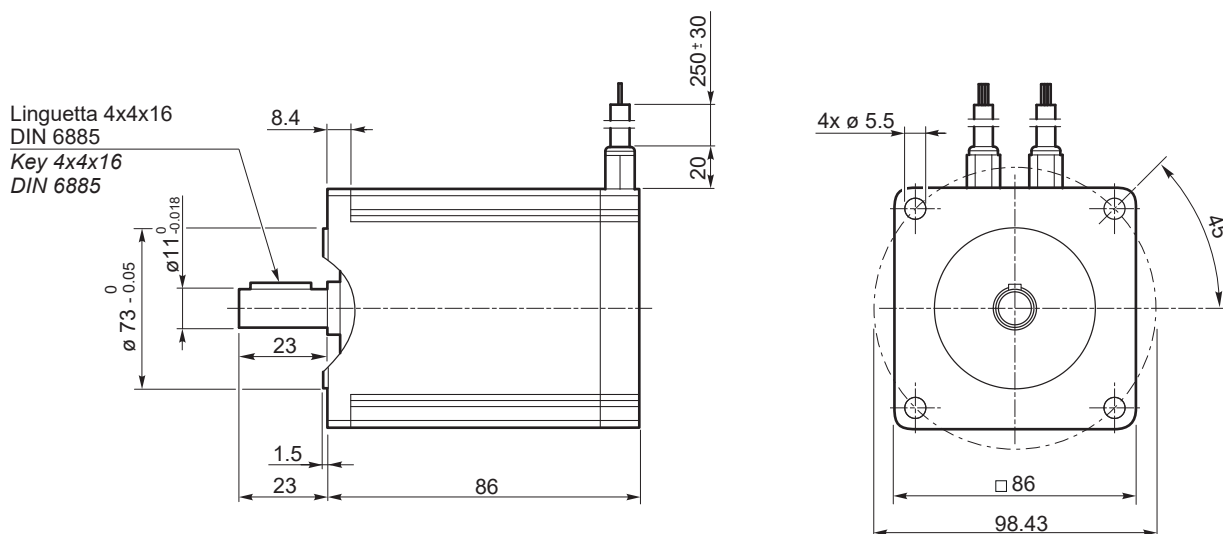
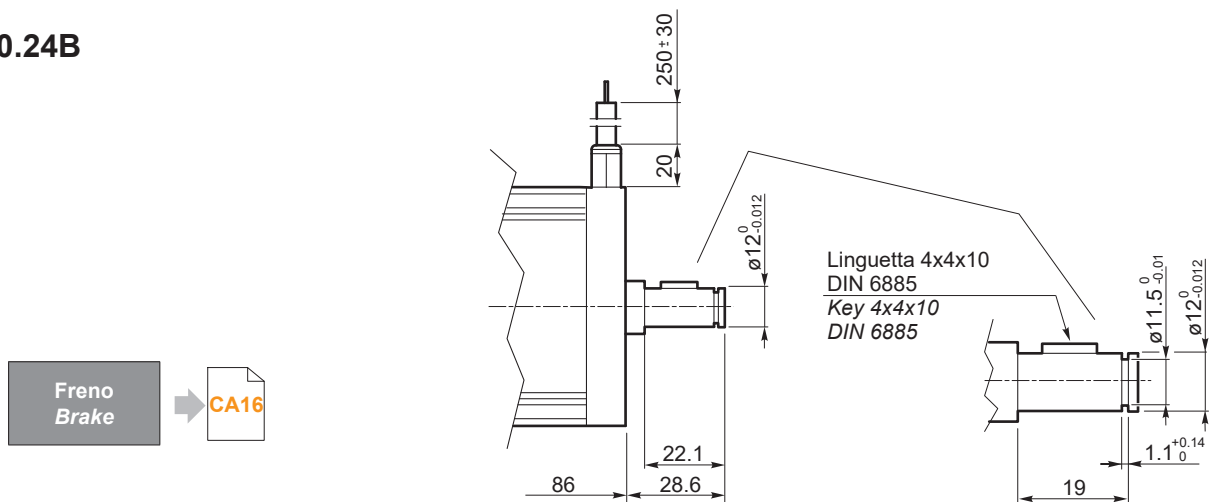

BL070.240 / BL070.24B
Dimensioni
Dimensions
BL070.240

BL070.24B

Diagramma dei collegamenti
Connection diagram

Cavi di potenza Power leads	Descrizione Description
Blu / Blue	Fase U / U motor Phase
Marrone / Brown	Fase V / V motor Phase
Nero / Black	Fase W / W motor Phase

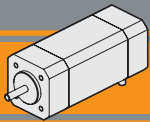
Cavi di segnale Signal leads	Descrizione Description
Blue	HALL fase U U phase HALL
Verde Green	HALL fase V V phase HALL
Bianco White	HALL fase W W phase HALL
Rosso (piccolo) Red (small)	Alimentazione HALL + 5Vcc ÷ + 24 Vcc Supply voltage for Hall sensors, + 5 Vdc ÷ + 24 Vdc
Nero (piccolo) Black (small)	Comune per i segnali di HALL Ground for HALL sensors

Nota: Si raccomanda di seguire fedelmente gli schemi di collegamento qui riportati, pericolo di danneggiamento del motore o dell'elettronica.

Note: Pls, follow strictly the above connection diagrams, danger for the motor and the electric control



BL070.480 / BL070.48B

Specifiche costruttive

General features

Tipologia di avvolgimento <i>Winding type</i>	Stella <i>Star</i>
Angolo sensori Hall <i>HALL effect angle</i>	120 gradi elettrici <i>120 degree electrical angle</i>
Gioco radiale <i>Radial play</i>	0.02 mm @ 450g
Gioco assiale <i>End play</i>	0.08 mm @ 450g
Scenatura albero <i>Shaft run out</i>	0.05 mm

Max forza radiale <i>Max radial force</i>	220N @ 20 mm dalla flangia <i>220N @ 20 mm from flange</i>
Max forza assiale <i>Max axial force</i>	60N
Classe di isolamento termico <i>Insulation class</i>	Classe B <i>Class B</i>
Isolamento dielettrico <i>Dielectric strength</i>	500Vcc x 1 minuto <i>500 Vdc 1 minute</i>
Resistenza isolamento <i>Insulation resistance</i>	100MΩ minimo, 500Vcc <i>100MΩ min, 500 Vdc</i>

Modello <i>Model</i>	Poli <i>Poles</i>	Fasi <i>Phases</i>	Tensione nominale	Velocità nominale	Coppia nominale	Potenza nominale	Coppia di picco	Corrente nominale	Corrente di picco	Resistenza fase-fase	Induttanza fase-fase	Costante di coppia	Costante FCEM	Inerzia rotore	Peso	IP
			<i>Rated voltage</i>	<i>Rated speed</i>	<i>Rated torque</i>	<i>Rated power</i>	<i>Peak torque</i>	<i>Rated current</i>	<i>Peak current</i>	<i>Line to line resistance</i>	<i>Line to line inductance</i>	<i>Torque constant</i>	<i>Back EMF</i>	<i>Rotor inertia</i>	<i>Weight</i>	
			[V]	[min ⁻¹]	[Nm]	[W]	[Nm]	[A]	[A]	[Ω]	[mH]	[Nm/A]	[V/kRPM]	[gcm ²]	[kg]	
BL070.480 BL070.48B	8	3	48	3000	0.7	220	2.1	6.5	20	0.34	1.0	0.107	9	800	2.1	55



Prestazioni

Performances

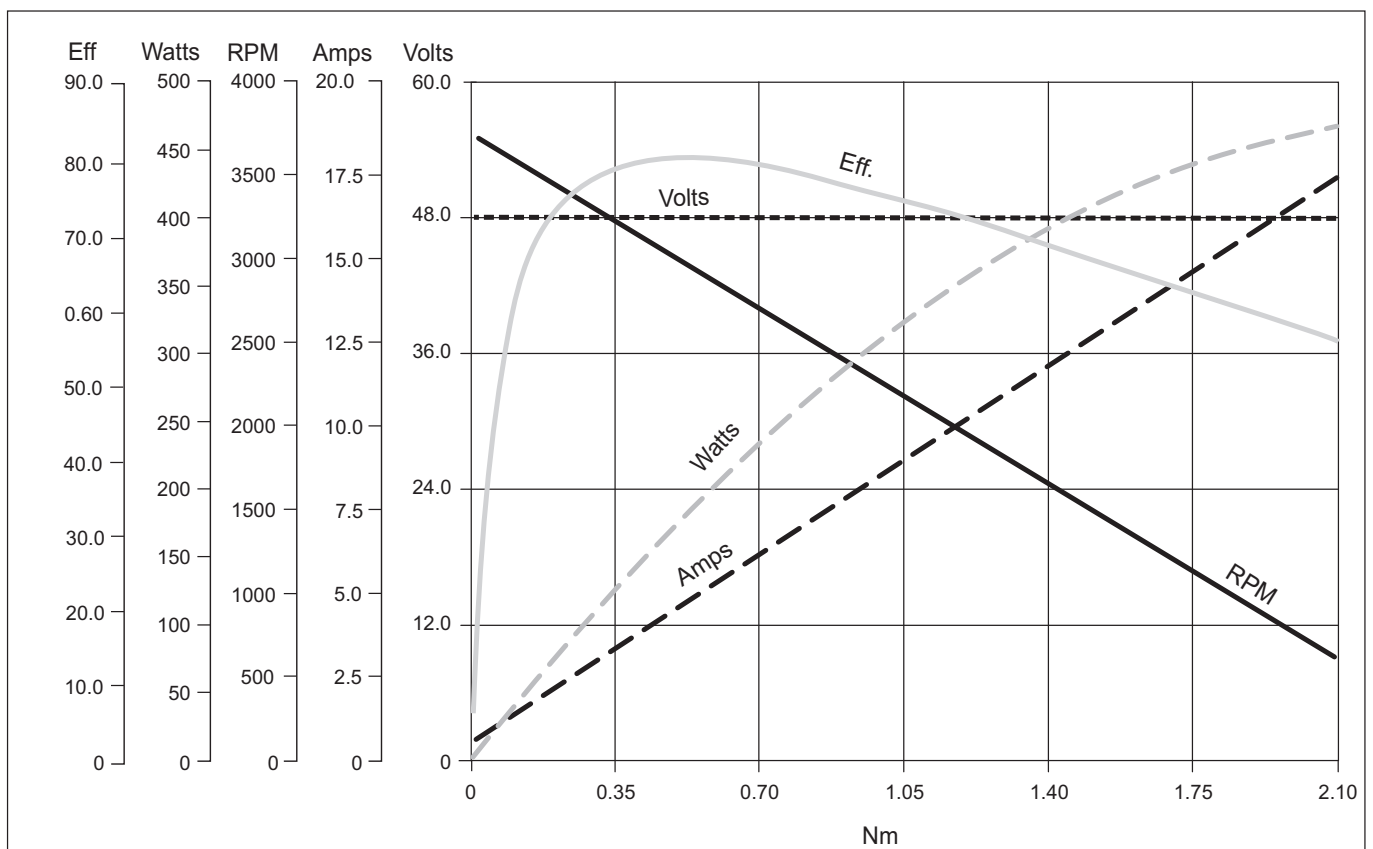

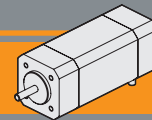
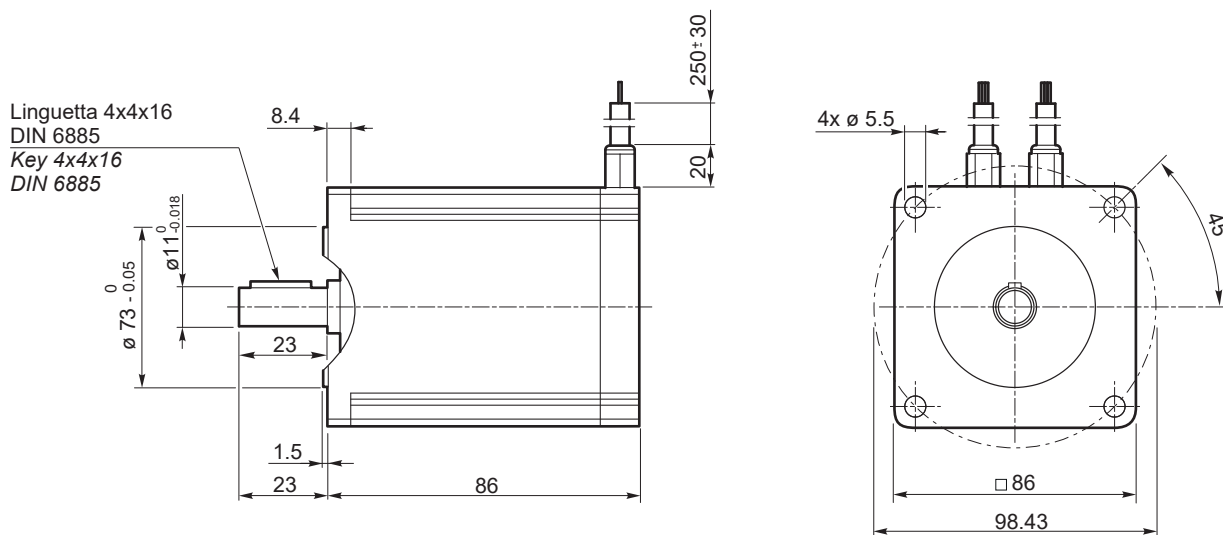
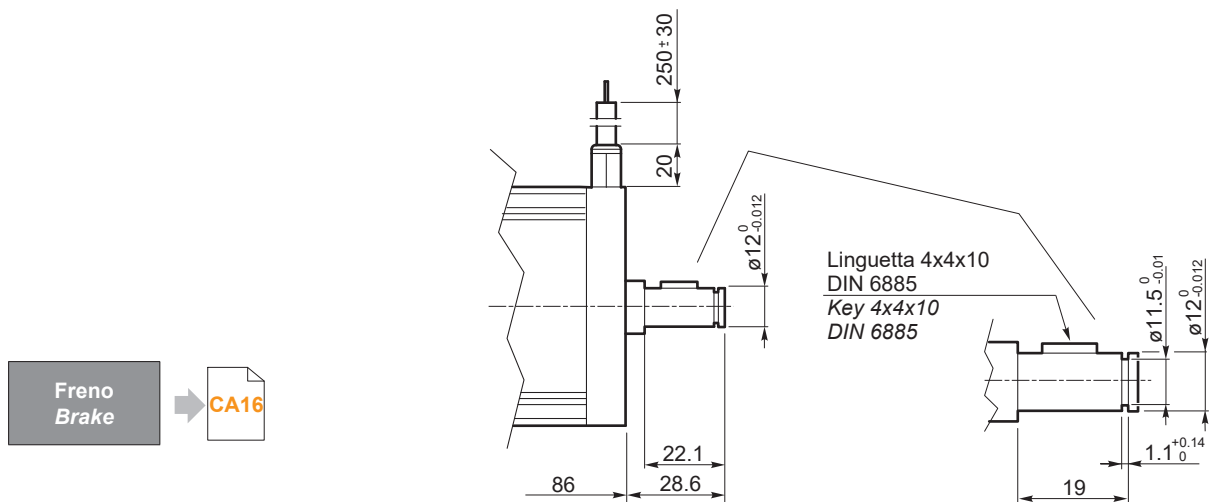

BL070.480 / BL070.48B
Dimensioni
Dimensions
BL070.480

BL070.48B

Diagramma dei collegamenti
Connection diagram

Cavi di potenza Power leads	Descrizione Description
Blu / Blue	Fase U / U motor Phase
Marrone / Brown	Fase V / V motor Phase
Nero / Black	Fase W / W motor Phase

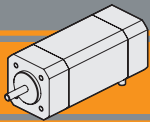
Nota: Si raccomanda di seguire fedelmente gli schemi di collegamento qui riportati, pericolo di danneggiamento del motore o dell'elettronica.

Note: Pls, follow strictly the above connection diagrams, danger for the motor and the electric control

Cavi di segnale Signal leads	Descrizione Description
Blue	HALL fase U U phase HALL
Verde Green	HALL fase V V phase HALL
Bianco White	HALL fase W W phase HALL
Rosso (piccolo) Red (small)	Alimentazione HALL + 5Vcc ÷ + 24 Vcc Supply voltage for Hall sensors, + 5 Vdc ÷ + 24 Vdc
Nero (piccolo) Black (small)	Comune per i segnali di HALL Ground for HALL sensors



BL140.480

Specifiche costruttive

General features

Tipologia di avvolgimento <i>Winding type</i>	Stella <i>Star</i>
Angolo sensori Hall <i>HALL effect angle</i>	120 gradi elettrici <i>120 degree electrical angle</i>
Gioco radiale <i>Radial play</i>	0.02 mm @ 450g
Gioco assiale <i>End play</i>	0.08 mm @ 450g
Scenatura albero <i>Shaft run out</i>	0.05 mm

Max forza radiale <i>Max radial force</i>	220N @ 20 mm dalla flangia <i>220N @ 20 mm from flange</i>
Max forza assiale <i>Max axial force</i>	60N
Classe di isolamento termico <i>Insulation class</i>	Classe B <i>Class B</i>
Isolamento dielettrico <i>Dielectric strength</i>	500Vcc x 1 minuto <i>500 Vdc 1 minute</i>
Resistenza isolamento <i>Insulation resistance</i>	100MΩ minimo, 500Vcc <i>100MΩ min, 500 Vdc</i>

Modello <i>Model</i>	Poli <i>Poles</i>	Fasi <i>Phases</i>	Tensione nominale	Velocità nominale	Coppia nominale	Potenza nominale	Coppia di picco	Corrente nominale	Corrente di picco	Resistenza fase-fase	Induttanza fase-fase	Costante di coppia	Costante FCEM	Inerzia rotore	Peso	IP
			<i>Rated voltage</i>	<i>Rated speed</i>	<i>Rated torque</i>	<i>Rated power</i>	<i>Peak torque</i>	<i>Rated current</i>	<i>Peak current</i>	<i>Line to line resistance</i>	<i>Line to line inductance</i>	<i>Torque constant</i>	<i>Back EMF</i>	<i>Rotor inertia</i>	<i>Weight</i>	
			[V]	[min ⁻¹]	[Nm]	[W]	[Nm]	[A]	[A]	[Ω]	[mH]	[Nm/A]	[V/kRPM]	[gcm ²]	[kg]	
BL140.480	8	3	48	3000	1.4	440	4.2	13	39	0.16	0.5	0.113	9.4	1600	3.15	55



Prestazioni

Performances

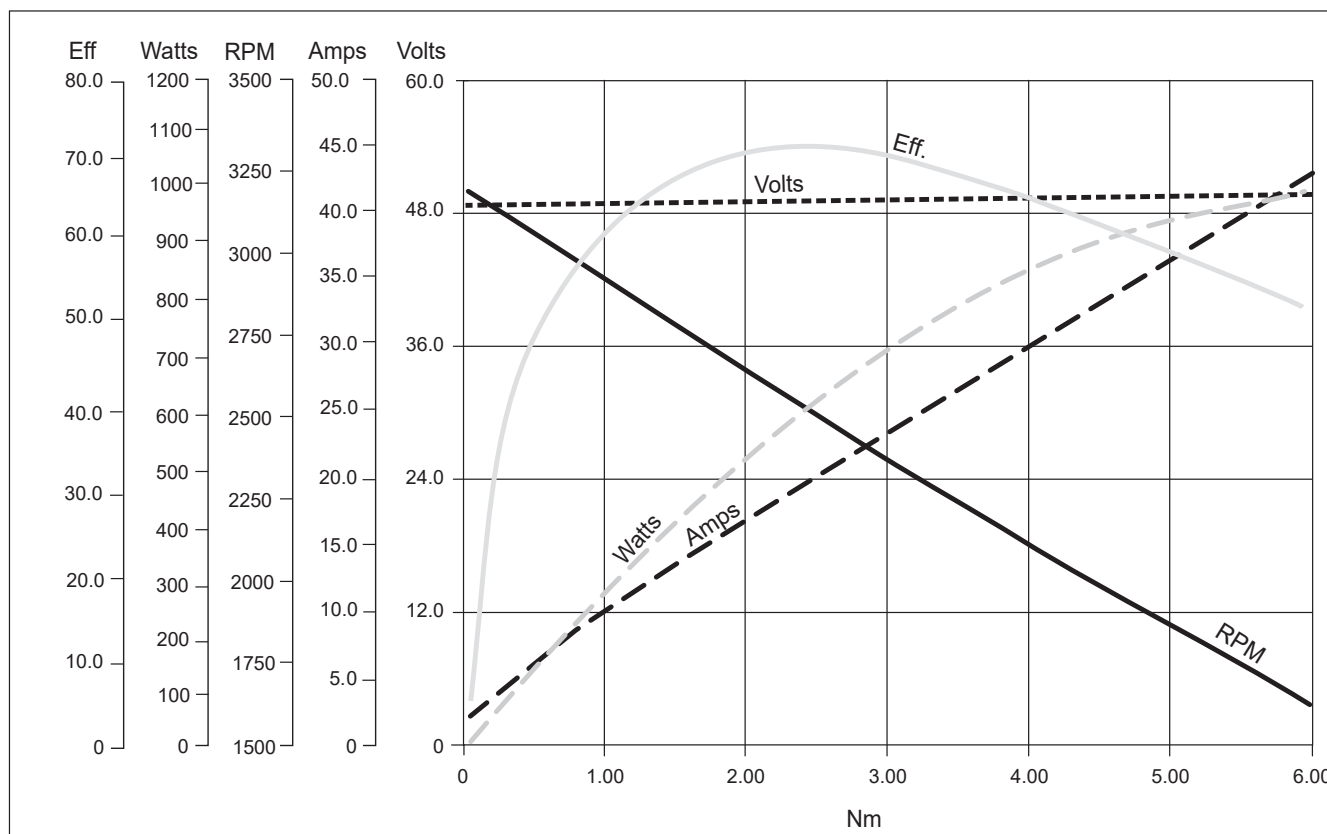

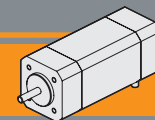
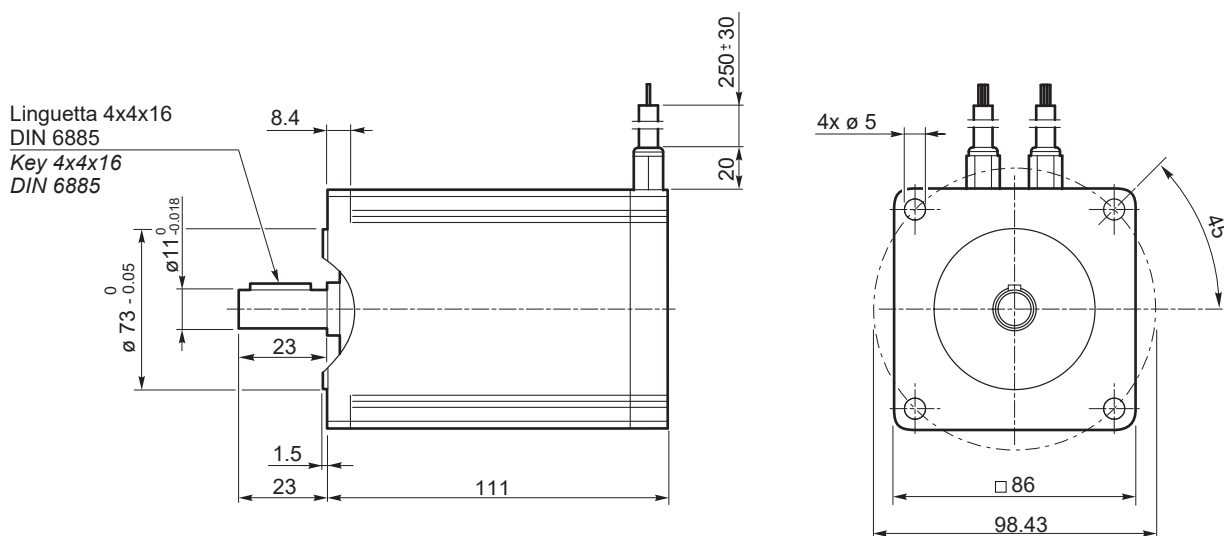

BL140.480
Dimensioni
Dimensions
BL140.480

Diagramma dei collegamenti
Connection diagram

Cavi di potenza Power leads	Descrizione Description
Blu / Blue	Fase U / U motor Phase
Marrone / Brown	Fase V / V motor Phase
Nero / Black	Fase W / W motor Phase

Cavi di segnale Signal leads	Descrizione Description
Blue	HALL fase U U phase HALL
Verde Green	HALL fase V V phase HALL
Bianco White	HALL fase W W phase HALL
Rosso (piccolo) Red (small)	Alimentazione HALL + 5Vcc ÷ + 24 Vcc Supply voltage for Hall sensors, + 5 Vdc ÷ + 24 Vdc
Nero (piccolo) Black (small)	Comune per i segnali di HALL Ground for HALL sensors

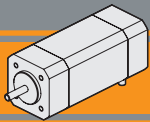
Nota: Si raccomanda di seguire fedelmente gli schemi di collegamento qui riportati, pericolo di danneggiamento del motore o dell'elettronica.

Note: Pls, follow strictly the above connection diagrams, danger for the motor and the electric control



BL210.480 / BL210.48E

Specifiche costruttive

General features

Tipologia di avvolgimento <i>Winding type</i>	Stella <i>Star</i>
Angolo sensori Hall <i>HALL effect angle</i>	120 gradi elettrici <i>120 degree electrical angle</i>
Gioco radiale <i>Radial play</i>	0.02 mm @ 450g
Gioco assiale <i>End play</i>	0.08 mm @ 450g
Scantatura albero <i>Shaft run out</i>	0.05 mm

Max forza radiale <i>Max radial force</i>	220N @ 20 mm dalla flangia <i>220N @ 20 mm from flange</i>
Max forza assiale <i>Max axial force</i>	60N
Classe di isolamento termico <i>Insulation class</i>	Classe B <i>Class B</i>
Isolamento dielettrico <i>Dielectric strength</i>	500Vcc x 1 minuto <i>500 Vdc 1 minute</i>
Resistenza isolamento <i>Insulation resistance</i>	100MΩ minimo, 500Vcc <i>100MΩ min, 500 Vdc</i>

Modello <i>Model</i>	Poli <i>Poles</i>	Fasi <i>Phases</i>	Tensione nominale	Velocità nominale	Coppia nominale	Potenza nominale	Coppia di picco	Corrente nominale	Corrente di picco	Resistenza fase-fase	Induttanza fase-fase	Costante di coppia	Costante FCEM	Inerzia rotore	Peso	IP
			<i>Rated voltage</i>	<i>Rated speed</i>	<i>Rated torque</i>	<i>Rated power</i>	<i>Peak torque</i>	<i>Rated current</i>	<i>Peak current</i>	<i>Line to line resistance</i>	<i>Line to line inductance</i>	<i>Torque constant</i>	<i>Back EMF</i>	<i>Rotor inertia</i>	<i>Weight</i>	
			[V]	[min ⁻¹]	[Nm]	[W]	[Nm]	[A]	[A]	[Ω]	[mH]	[Nm/A]	[V/kRPM]	[gcm ²]	[kg]	
BL210.480 BL210.48E	8	3	48	3000	2.1	660	6.3	18.7	56	0.115	0.31	0.112	9.5	2400	4.2	55



Prestazioni

Performances

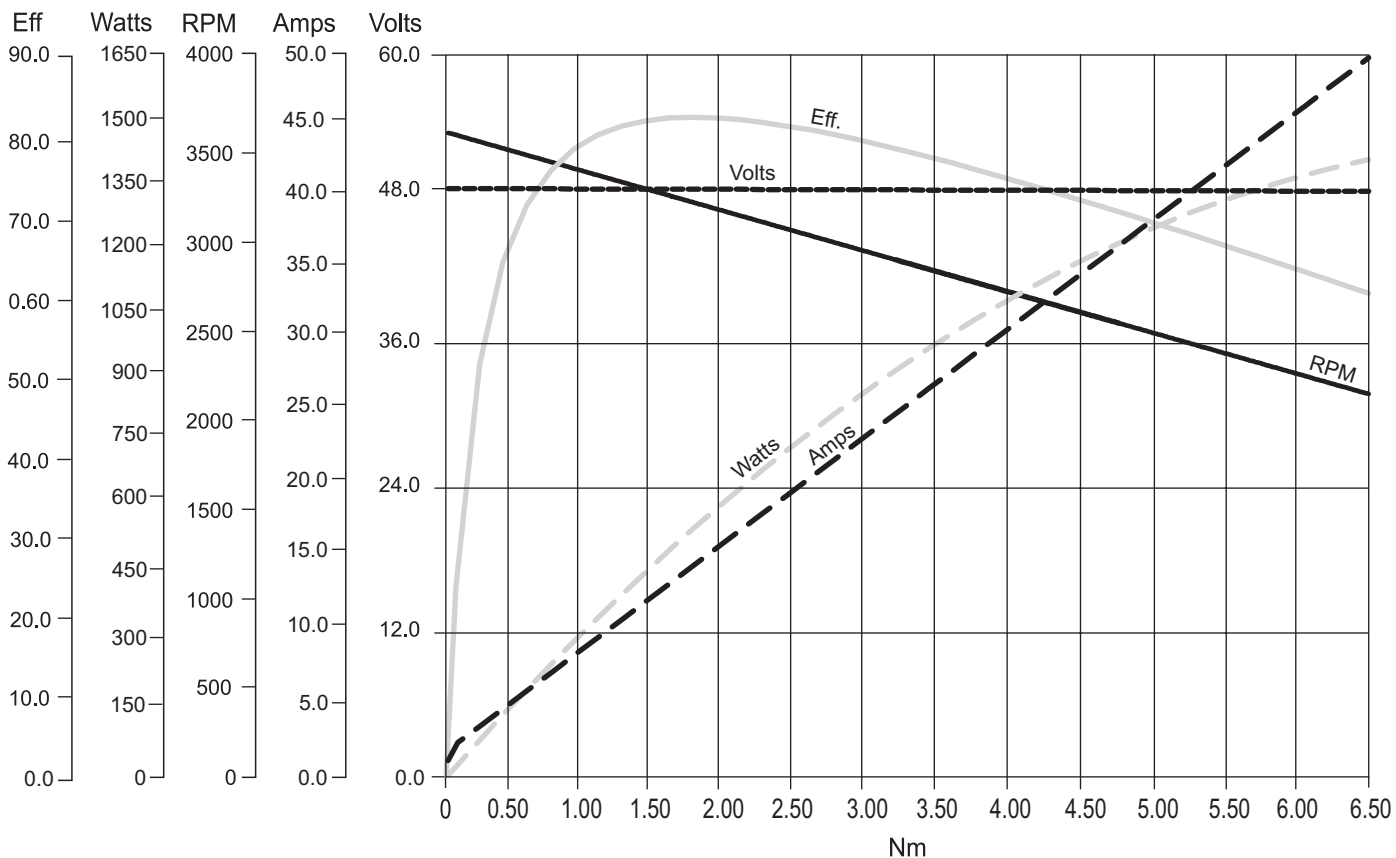

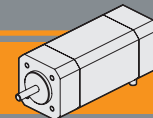
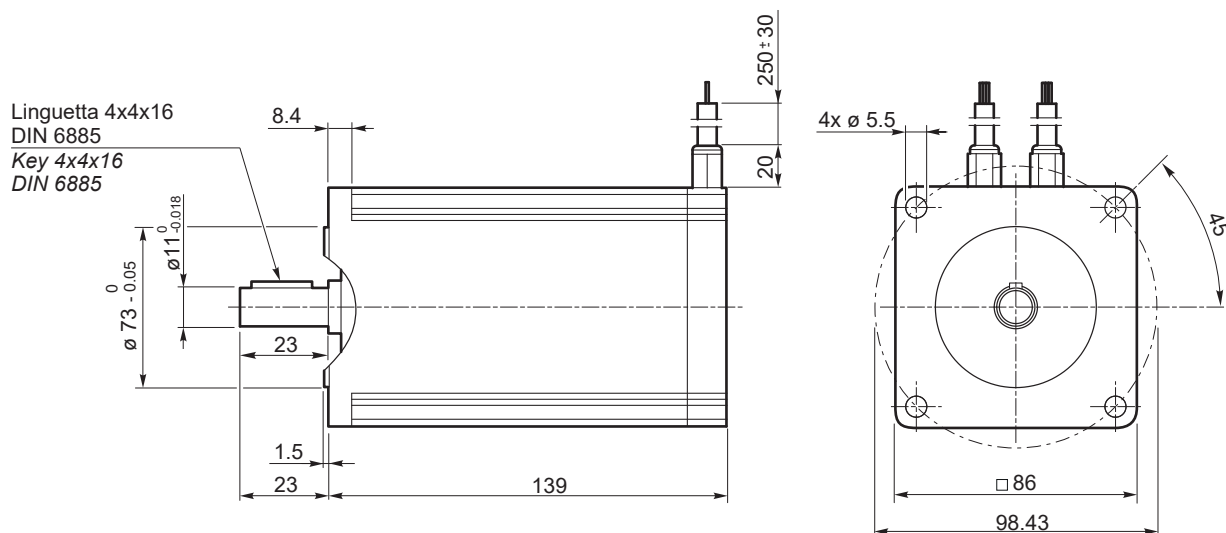
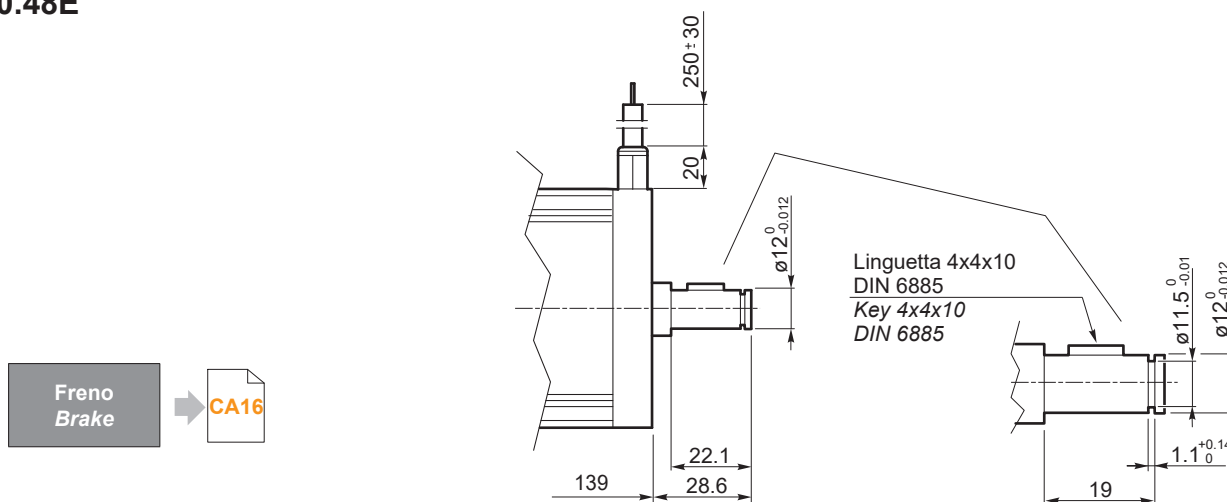

BL210.480 / BL210.48E
Dimensioni
Dimensions
BL210.480

BL210.48E

Diagramma dei collegamenti
Connection diagram

Cavi di potenza Power leads	Descrizione Description
Blu / Blue	Fase U / U motor Phase
Marrone / Brown	Fase V / V motor Phase
Nero / Black	Fase W / W motor Phase

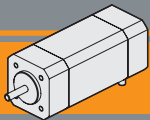
Cavi di segnale Signal leads	Descrizione Description
Blue	HALL fase U U phase HALL
Verde Green	HALL fase V V phase HALL
Bianco White	HALL fase W W phase HALL
Rosso (piccolo) Red (small)	Alimentazione HALL + 5Vcc ÷ + 24 Vcc Supply voltage for Hall sensors, + 5 Vdc ÷ + 24 Vdc
Nero (piccolo) Black (small)	Comune per i segnali di HALL Ground for HALL sensors

Nota: Si raccomanda di seguire fedelmente gli schemi di collegamento qui riportati, pericolo di danneggiamento del motore o dell'elettronica.

Note: Pls, follow strictly the above connection diagrams, danger for the motor and the electric control



Freno

Brake

Freno / Brake

Freno con leva di sblocco/ Brake with hand release

BL070.24B-BR
BL070.48B-BR
BL210.48E-BR

BL070.24B-BRL
BL070.48B-BRL
BL210.48E-BRL

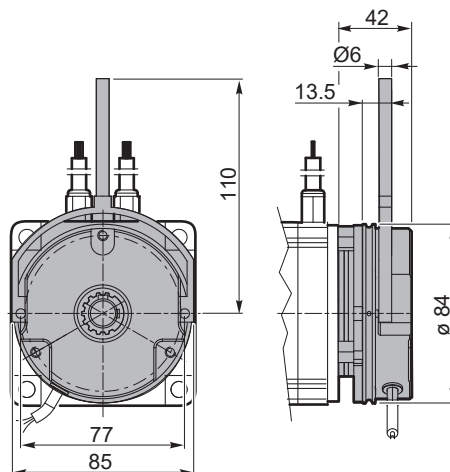
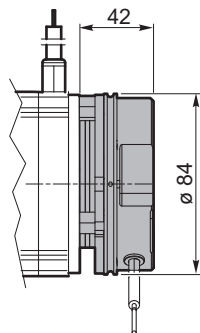

	P_n [W]	V [V]	M_n [Nm]	n₁ [min ⁻¹]	Kg	IP
Caratteristiche del freno / Break features	23	48	4.5	3000	0.90	20

Motoriduttori brushless CC ad assi ortogonali Brushless DC helical bevel gearmotors

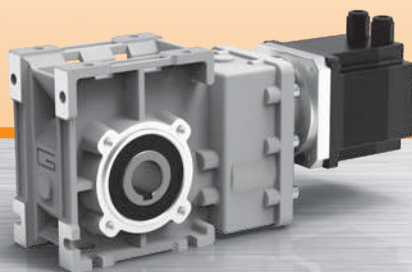

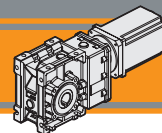

Indice	Index	Pag. Page
Caratteristiche tecniche	<i>Technical features</i>	CB2
Designazione	<i>Classification</i>	CB2
Simbologia	<i>Symbols</i>	CB3
Lubrificazione e temperatura	<i>Lubrication and temperature</i>	CB3
Carichi radiali	<i>Radial loads</i>	CB3
CMB402 con motore brushless BLS043.240	<i>CMB402 with BLS043.240 brushless motor</i>	CB4
CMB402 con motore brushless BL070.240	<i>CMB402 with BL070.240 brushless motor</i>	CB5
CMB402 con motore brushless BL070.24B	<i>CMB402 with BL070.24B brushless motor</i>	CB5
CMB402 con motore brushless BL070.480	<i>CMB402 with BL070.480 brushless motor</i>	CB5
CMB402 con motore brushless BL070.48B	<i>CMB402 with BL070.48B brushless motor</i>	CB5
CMB402 con motore brushless BL140.480	<i>CMB402 with BL140.480 brushless motor</i>	CB6
Dati tecnici	<i>Technical data</i>	CB7
Dimensioni CMB con flange motore AS	<i>CMB dimensions with motor flanges AS</i>	CB8
Flange uscita	<i>Output flange</i>	CB9
Accessori	<i>Accessories</i>	CB10

Questa sezione annulla e sostituisce ogni precedente edizione o revisione. Qualora questa sezione non Vi sia giunta in distribuzione controllata, l'aggiornamento dei dati ivi contenuto non è assicurato. **In tal caso la versione più aggiornata è disponibile sul nostro sito internet www.transtecno.com**

This section replaces any previous edition and revision. If you obtained this catalogue other than through controlled distribution channels, the most up to date content is not guaranteed. In this case the latest version is available on our web site www.transtecno.com

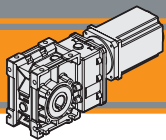

Caratteristiche tecniche

Technical features

Le caratteristiche principali dei motoriduttori brushless CC ad assi ortogonali della serie BLCMB sono:

The main features of BLCMB brushless DC helical bevel gearmotors range are:

- Alimentazione in bassa tensione 24/36/48 Vcc
- Motore Brushless CC con grado di protezione IP55
- Coppie motori disponibili da 0.43 Nm a 1.4 Nm
- Lubrificazione permanente con olio sintetico
- Carcassa in pressofusione di alluminio
- Ingranaggi cilindrici a denti elicoidali, induriti e rettificati
- Disponibili anche nella versione con solo riduttore, sia con flangia di entrata standard che con flangia e manicotto dedicati
- Disponibili con giunto elastico in entrata

- Low voltage power supply 24/36/48 Vdc
- Brushless DC motor in IP55 protection Standard
- Motor torque ratings available from 0.43 Nm up to 1.4 Nm
- Permanent synthetic oil long life lubrication
- Die-cast aluminium housing
- Ground-hardened helical gears.
- Gearbox only version also available, with either standard input flange or customized flange and coupling
- Available with input flexible coupling

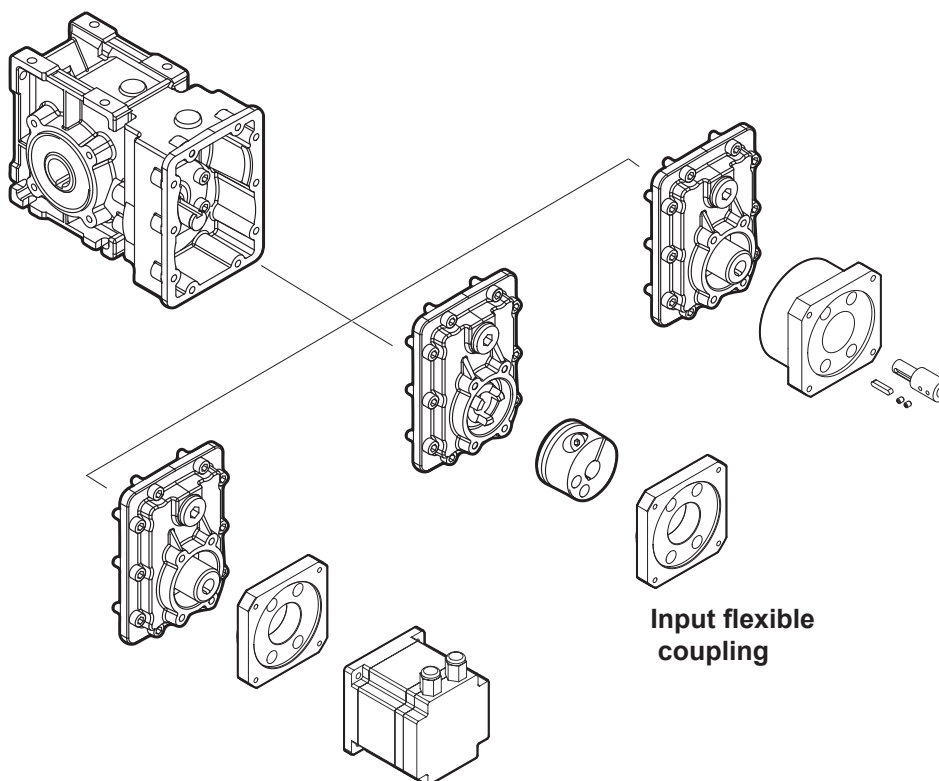

Designazione

Classification

RIDUTTORE / GEARBOX						MOTORE / MOTOR		
CMB	402	U	9.2	020	FX	BL070.480	48V	BR
Tipo Type	Grandezza Size	Versione riduttore Gearbox version	Rapporto Ratio	Albero di uscita Output shaft	Giunto elastico Flexible coupling	Tipo Type	Tensione Voltage	Freno Brake
CMB	402	U FD FS FLD FLS FBD FBS	Vedere tabelle See tables		FX 	BLS043.240 BL070.240 BL070.24B BL070.48B BL070.480 BL140.480	24V-36V 24V 24V 48V 48V 48V	24V 48V
Versione Riduttore Gearbox Version		Albero di uscita Output shaft		Braccio di reazione Torque arm *		Angolo Angle		

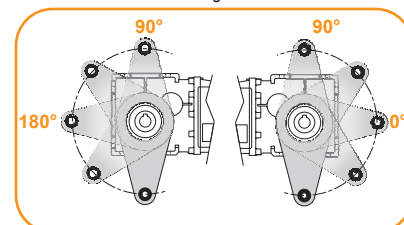
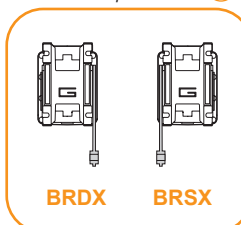
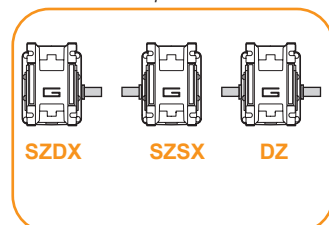
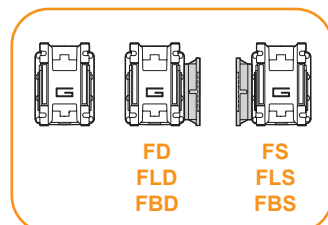

* NOTA: il braccio di reazione viene fornito smontato.
NOTE: the torque arm will be supplied not assembled.

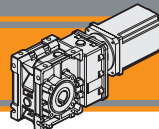

Simbologia

Symbols

Ns	n° stadi / No. stages	Mn ₂	[Nm]	Coppia nominale in uscita in funzione di Pn1 Nominal output torque referred to Pn1
ir	rapporto reale / real ratio	n _{1MAX}	[Rpm]	Velocità max entrata / Max input speed
M ₂	[Nm]	V	[V]	Tensione / Voltage
A ₂	[N]	n ₂	[Rpm]	Velocità in uscita / Output Speed
R ₂	[N]	IP		Grado di protezione / Enclosure protection
Pn ₁	[kW]	Kg		Peso / Weight
		sf		Fattore di servizio / Service Factor

Lubrificazione e temperatura

Lubrication and temperature

I motoriduttori BLCMB sono forniti completi di lubrificante sintetico (viscosità 320) e non necessitano di manutenzione.
Temperatura ambiente 0 ÷ 40 °C (in assenza di congelamento ed in assenza di condensa).
Per temperature diverse, contattare nostro UT.

Permanent synthetic oil long life lubrication (viscosity grade 320) on BLCMB gearmotors.
Ambient temperature 0 ÷ 40 °C (in the absence of freezing and condensation).
For temperature outside this range please contact our technical dept.

Carichi radiali

Radial loads

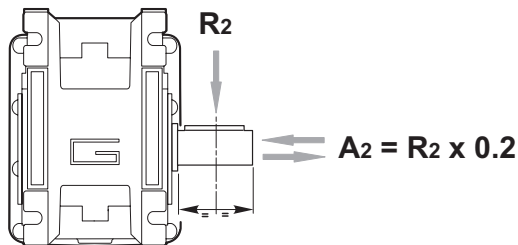

n ₂ [min ⁻¹]	R ₂ [N]
	CMB 402
400	905
300	996
200	1141
170	1204
140	1414
100	1582
90	1638
60	2047
40	2524
30	2778
20	3180
15	3500
10	3500

Quando il carico radiale risultante non è applicato sulla mezzeria dell'albero occorre calcolare quello effettivo con la seguente formula

When the resulting radial load is not applied on the centre line of the shaft it is necessary to calculate the effective load with the following formula:

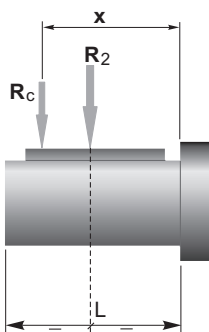

	CMB 402
a	86
b	66
R _{2MAX}	3500

$$R_c = \frac{R_2 \cdot a}{(b + x)} \leq R_{2MAX}$$

$$R \leq R_c$$

a. b = valori riportati nella tabella
a. b = values given in the table

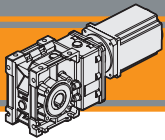

CMB402	BLS043.240													
	24V						36V							
	n _{2MIN} [rpm]			n _{2MAX} [rpm]			n _{1MAX} [rpm]	n _{2MIN} [rpm]			n _{2MAX} [rpm]		n _{1MAX} [rpm]	
M ₂ [Nm]	sf		M ₂ [Nm]	sf		M ₂ [Nm]		sf		M ₂ [Nm]	sf			
6.2	49	2.5	18.4	486	2.5	12.5	3000	65	2.5	18.4	648	2.5	11.1	4000
7.5	40	3.0	15.2	400	3.0	10.3		53	3.0	15.2	534	3.0	9.1	
9.2	33	3.7	12.4	326	3.7	8.4		43	3.7	12.4	435	3.7	7.4	
11.8	25	4.8	10.8	254	4.8	7.3		34	4.8	10.8	338	4.8	6.5	
12.5	24	5.0	10.3	240	5.0	7.0		32	5.0	10.3	320	5.0	6.2	
14.8	20	6.0	8.6	202	6.0	5.9		27	6.0	8.6	270	6.0	5.2	
17.6	17	7.1	7.3	170	7.1	4.9		23	7.1	7.3	227	7.1	4.4	
18.6	16	7.5	8.4	161	7.5	5.7		22	7.5	8.4	215	7.5	5.0	
22.3	13	9.0	7.0	134	9.0	4.8		18	9.0	7.0	179	9.0	4.2	
23.9	13	9.7	6.5	125	9.7	4.4		17	9.7	6.5	167	9.7	3.9	
28.9	10	12	6.4	104	12	4.3		14	12	6.4	138	12	3.8	
30.8	9.7	12	6.0	97	12	4.1		13	12	6.0	130	12	3.6	
33.6	8.9	14	5.5	89	14	3.7		12	14	5.5	119	14	3.3	
35.6	8.4	14	5.2	84	14	3.5		11	14	5.2	112	14	3.1	
42.8	7.0	17	4.3	70	17	2.9		9.4	17	4.3	94	17	2.6	
55.3	5.4	22	3.3	54	22	2.3		7.2	22	3.3	72	22	2.0	
59.1	5.1	24	3.1	51	24	2.1		6.8	24	3.1	68	24	1.9	
64.3	4.7	26	2.9	47	26	2.0		6.2	26	2.9	62	26	1.7	
72.5	4.1	29	2.6	41	29	1.7		5.5	29	2.6	55	29	1.5	

NOTA: per servizio continuo o altamente intermittente, contattare il servizio tecnico

NOTE: for continuous or highly intermittent duty, please contact our technical service

Tipo Type	Numero di poli Number of poles	Numero di fasi Number of phase	Tensione Rated voltage [V]	Numero di giri Rated speed [rpm]	Coppia nominale Rated torque [Nm]	Potenza nominale Rated power [W]
BLS043.240	4	3	36	4000	0.43	180
			24	3000		130
Tipo Type	Coppia massima Peak torque [Nm]	Corrente nominale Rated current [A]	Resistenza Resistance [ohm]	Induttanza Inductance [mH]	Corrente massima Peak current [A]	Peso Weight [kg]
BLS043.240	0.86	6	0.35	1	12.0	1.25

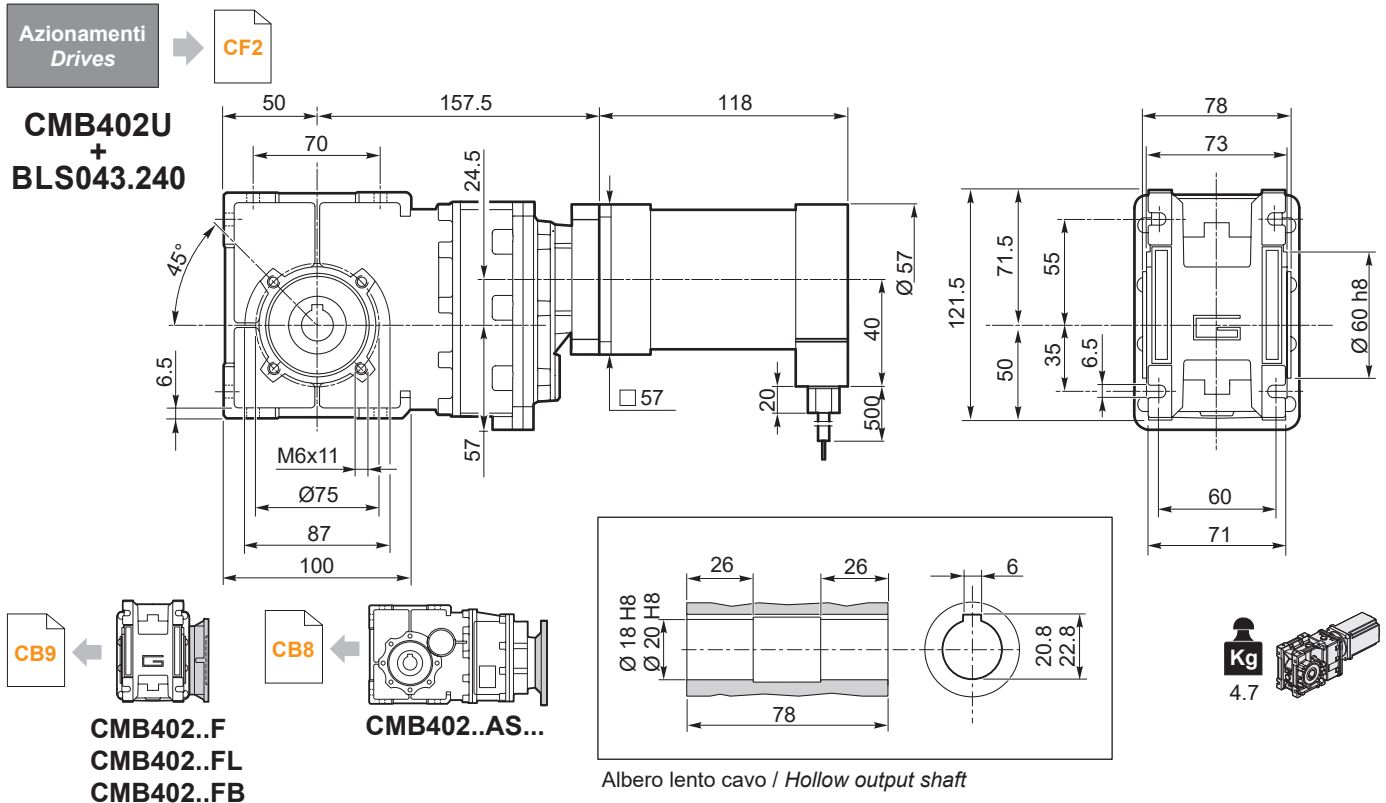

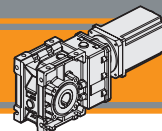

CMB402 con motore brushless CC

CMB402 with brushless DC motor

CMB402	BL070.240 / BL070.24B / BL070.480 / BL070.48B					
	24V / 48V					
	ir	n _{2MIN} [rpm]			n _{2MAX} [rpm]	
M ₂ [Nm]		sf	M ₂ [Nm]	sf	n _{1MAX} [rpm]	
6.2	49	4.1	11.3	486	4.1	7.7
7.5	40	4.9	9.3	400	4.9	6.3
9.2	33	6.1	7.6	326	6.1	5.2
11.8	25	7.8	6.6	254	7.8	4.5
12.5	24	8.2	6.3	240	8.2	4.3
14.8	20	9.8	5.3	202	9.8	3.6
17.6	17	12	4.5	170	12	3.0
18.6	16	12	5.2	161	12	3.5
22.3	13	15	4.3	134	15	2.9
23.9	13	16	4.0	125	16	2.7
28.9	10	19	3.9	104	19	2.7
30.8	9.7	20	3.7	97	20	2.5
33.6	8.9	22	3.4	89	22	2.3
35.6	8.4	23	3.2	84	23	2.2
42.8	7.0	28	2.7	70	28	1.8
55.3	5.4	36	2.1	54	36	1.4
59.1	5.1	39	1.9	51	39	1.3
64.3	4.7	42	1.8	47	42	1.2
72.5	4.1	48	1.6	41	48	1.1

NOTA: per servizio continuo o altamente intermittente, contattare il servizio tecnico

NOTE: for continuous or highly intermittent duty, please contact our technical service

Tipo Type	Numero di poli Number of poles	Numero di fasi Number of phase	Tensione Rated voltage [V]	Numero di giri Rated speed [rpm]	Coppia nominale Rated torque [Nm]	Potenza nominale Rated power [W]
BL070.240 BL070.24B	8	3	24	3000	0.7	220
BL070.480 BL070.48B	8	3	48	3000	0.7	220

Tipo Type	Coppia massima Peak torque [Nm]	Corrente nominale Rated current [A]	Resistenza Resistance [ohm]	Induttanza Inductance [mH]	Corrente massima Peak current [A]	Peso Weight [kg]
BL070.240 BL070.24B	2.1	13	0.091	0.23	26	2.1
BL070.480 BL070.48B	1.4	6.5	0.34	1.0	13	2.1

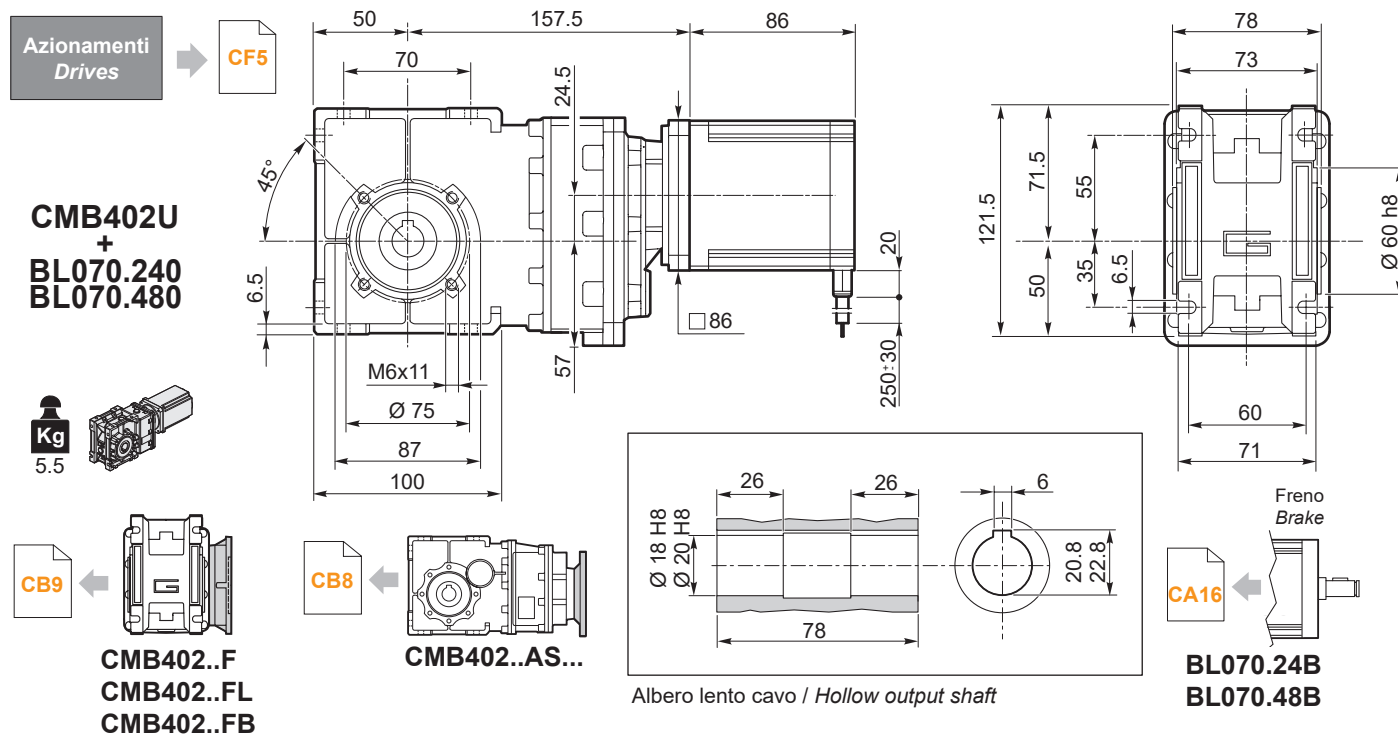

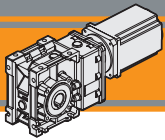

CMB402	BL140.480					
	48V					
	ir	n _{2MIN} [rpm]			n _{2MAX} [rpm]	
		M ₂ [Nm]	sf		M ₂ [Nm]	sf
6.2	49	8.1	5.7	486	8.1	3.8
7.5	40	9.9	4.7	400	9.9	3.2
9.2	33	12.1	3.8	326	12.1	2.6
11.8	25	15.6	3.3	254	15.6	2.3
12.5	24	16.4	3.1	240	16.4	2.1
14.8	20	19.5	2.7	202	19.5	1.8
17.6	17	23	2.2	170	23	1.5
18.6	16	24	2.6	161	24	1.8
22.3	13	29	2.2	134	29	1.5
23.9	13	31	2.0	125	31	1.4
28.9	10	38	2.0	104	38	1.3
30.8	9.7	41	1.8	97	41	1.2
33.6	8.9	44	1.7	89	44	1.1
35.6	8.4	47	1.6	84	47	1.1
42.8	7.0	56	1.3	70	56	0.9
55.3	5.4	73	1.0	54	72	0.7
59.1	5.1	78	1.0	51	72	0.7
64.3	4.7	85	0.9	47	72	0.7
72.5	4.1	95	0.8	41	72	0.7

NOTA: per servizio continuo o altamente intermittente, contattare il servizio tecnico

NOTE: for continuous or highly intermittent duty, please contact our technical service

Attenzione: superamento della coppia nominale supportata dal riduttore per servizio S1. Contattare il ns. servizio tecnico
Attention: rated torque withstood by gear reducer for service in S1 is exceeded. Please. contact our technical office.

Tipo Type	Numero di poli Number of poles	Numero di fasi Number of phase	Tensione Rated voltage [V]	Numero di giri Rated speed [rpm]	Coppia nominale Rated torque [Nm]	Potenza nominale Rated power [W]
BL140.480	8	3	48	3000	1.4	440
Tipo Type	Coppia massima Peak torque [Nm]	Corrente nominale Rated current [A]	Resistenza Resistance [ohm]	Induttanza Inductance [mH]	Corrente massima Peak current [A]	Peso Weight [kg]
BL140.480	2.8	13.0	0.16	0.5	26	3.15

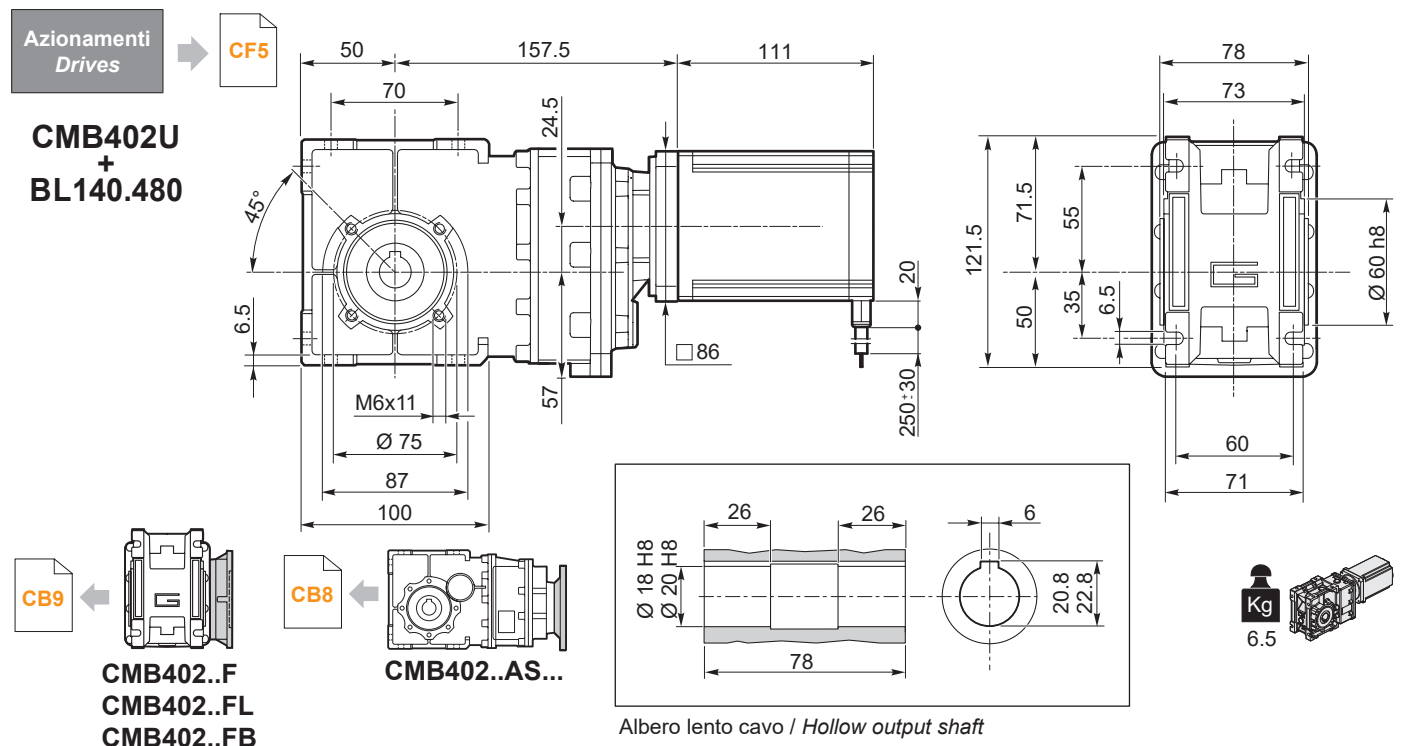

Albero lento cavo / Hollow output shaft

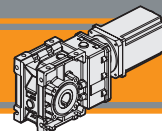

Dati tecnici

Technical data

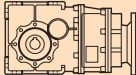
	n_2 [min ⁻¹]	Mn_2 [Nm]	Pn_1 [kW]	i
CMB 402				
$n_1 = 1400$ rpm	227	40	1.0	6.18
	187	40	0.83	7.49
	152	40	0.68	9.2
	118	45	0.59	11.83
	112	45	0.56	12.48
	94.4	45	0.47	14.83
	79.4	45	0.40	17.63
	75.3	55	0.46	18.6
	62.7	55	0.38	22.33
	58.6	55	0.36	23.91
	48.5	65	0.35	28.89
	45.4	65	0.33	30.84
	41.7	65	0.30	33.57
	39.3	65	0.28	35.63
	32.7	65	0.24	42.75
	25.3	65	0.18	55.31
	23.7	65	0.17	59.06
	21.8	65	0.16	64.29
	19.3	65	0.14	72.50

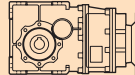
	n_2 [min ⁻¹]	Mn_2 [Nm]	Pn_1 [kW]	i
CMB 402				
$n_1 = 3000$ rpm	486	31.2	1.65	6.18
	400	31.2	1.36	7.49
	326	31.2	1.11	9.20
	254	35.1	0.97	11.83
	240	35.1	0.92	12.48
	202	35.1	0.77	14.83
	170	35.1	0.65	17.63
	161	42.9	0.75	18.60
	134	42.9	0.63	22.33
	126	42.9	0.59	23.91
	104	50.7	0.57	28.89
	97.3	50.7	0.54	30.84
	89.4	50.7	0.49	33.57
	84.2	50.7	0.47	35.63
	70.2	50.7	0.39	42.75
	54.2	50.7	0.30	55.31
	50.8	50.7	0.28	59.06
	46.7	50.7	0.26	64.29
	41.4	50.7	0.23	72.50

NOTA: per servizio continuo o altamente intermittente, contattare il servizio tecnico

NOTE: for continuous or highly intermittent duty, please contact our technical service

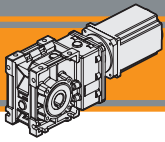

Dimensioni CMB con flange motore AS

CMB dimensions with motor flanges AS

CMB402 - U - AS...

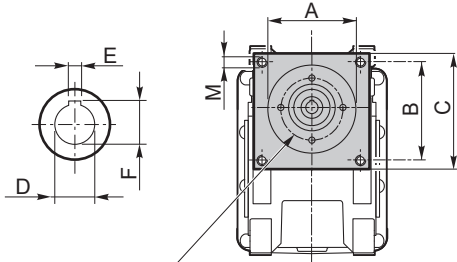

Connessione con boccola o giunto in funzione del diametro dell'albero motore.

Connection with sleeve or coupling depending on motorshaft's diameter.

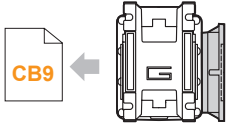

CMB402..F
CMB402..FL
CMB402..FB

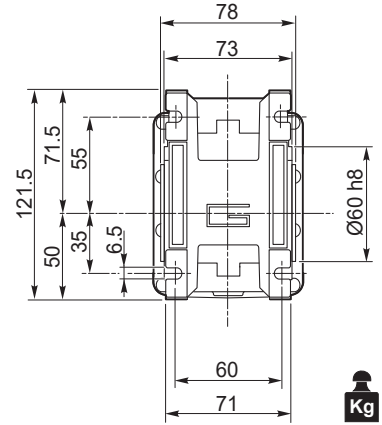
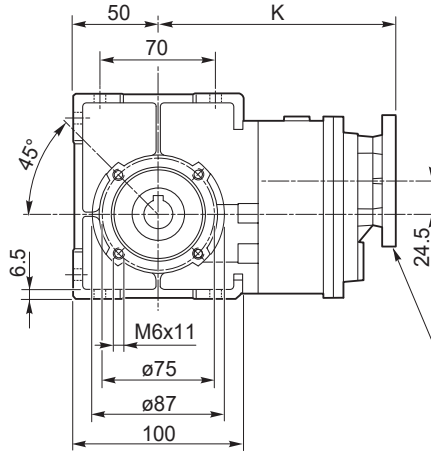

3.4

Lo spessore della flangia è variabile in funzione delle diverse lunghezze dell'albero motore.

Flange's thickness may vary depending on motorshaft's lenght.

Dimensioni / Dimensions								
AS	A	B	C	M	K	D	E	F
AS392FX	38.1	47.1	64	M5	157.5	9	3	10.5
						11	4	12.8
						14	5	16.3
AS384FX	73	69.6	86	M5	157.5	9	3	10.5
						11	4	12.8
						14	5	16.3
...

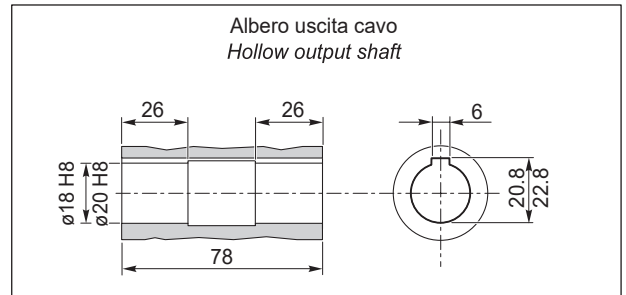

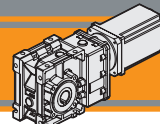

Flange uscita

Output flange

Flange uscita / Output flanges																											
CMB	F										FL										FB						
	a ₁	KA	KB	KC	KM	KN H8	KO	KP	KQ	a ₁	KA	KB	KC	KM	KN H8	KO	KP	KQ	a ₁	KA	KB	KC	KM	KN H8	KO	KP	KQ
402	45°	67	7.5	4.5	80-95	60	9	110	95	45°	97	7.5	4.5	80-95	60	9	110	95	45°	80	8.5	5	115-125	95	9.5	140	112

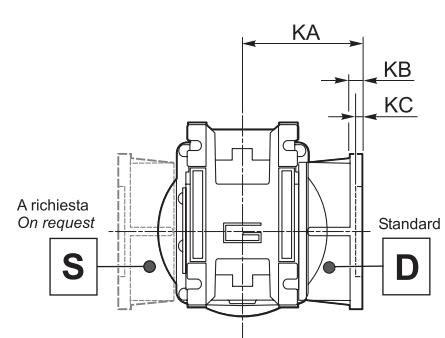
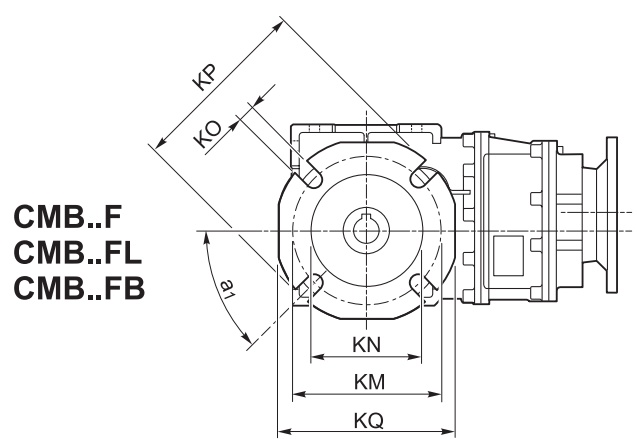

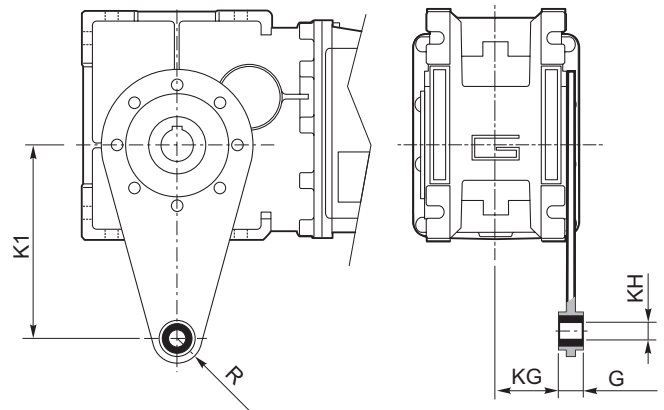
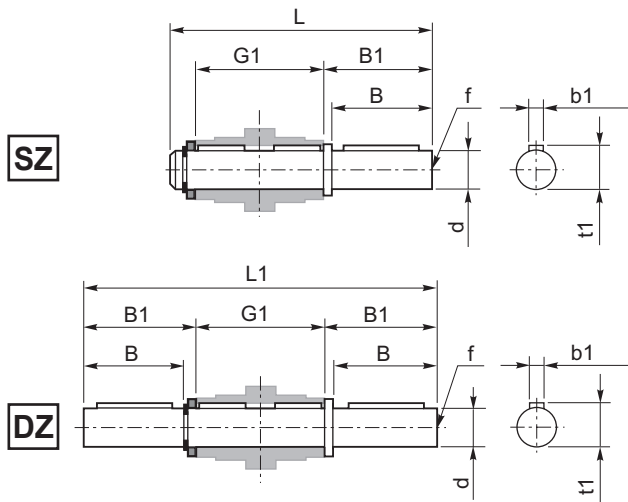
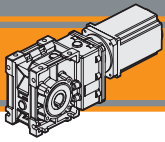

Albero lento / Output shaft

CMB	d h7	B	B1	G1	L	L1	f	b1	t1
402	18	40	43	78	128	164	M6	6	20.5

Braccio di reazione / Torque arm

CMB	K1	G	KG	KH	R
402	100	14	31	10	18

SC - Safety cover

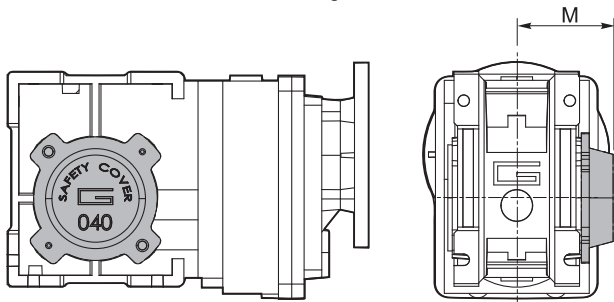

CMB	M
402	54.5

WD - Kit washdown cover

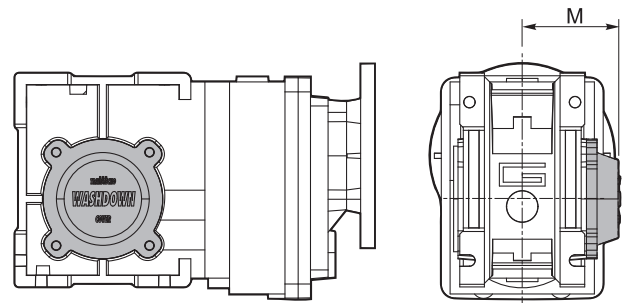

CMB	M
402	55.5

MINITM
TECNO
small but strong

BLFT

Motoriduttori brushless CC pendolari
Brushless DC helical parallel gearmotors

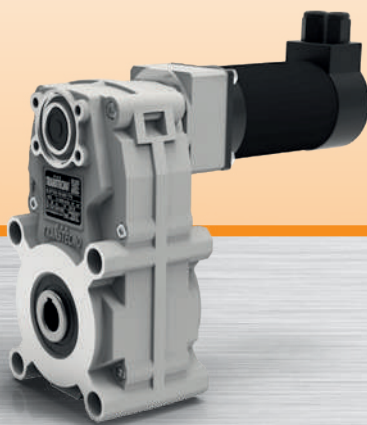

MINITM
TECNO brand of
TRANSTECNO[®]



BLDC



Indice	Index	Pag. Page
Caratteristiche tecniche	<i>Technical features</i>	CC2
Designazione	<i>Classification</i>	CC2
Simbologia	<i>Symbols</i>	CC3
Lubrificazione e temperatura	<i>Lubrication and temperature</i>	CC3
Carichi radiali	<i>Radial loads</i>	CC3
FT105 con motore brushless BLS022.240	<i>FT105 with BLS022.240 brushless motor</i>	CC4
FT105 con motore brushless BLS043.240	<i>FT105 with BLS043.240 brushless motor</i>	CC5
Dati tecnici	<i>Technical data</i>	CC6
Dimensioni FT con flange motore AS	<i>FT dimensions with motor flanges AS</i>	CC6

Questa sezione annulla e sostituisce ogni precedente edizione o revisione. Qualora questa sezione non Vi sia giunta in distribuzione controllata, l'aggiornamento dei dati ivi contenuto non è assicurato. **In tal caso la versione più aggiornata è disponibile sul nostro sito internet www.transtecno.com**

This section replaces any previous edition and revision. If you obtained this catalogue other than through controlled distribution channels, the most up to date content is not guaranteed. In this case the latest version is available on our web site www.transtecno.com



Caratteristiche tecniche

Technical features

Le caratteristiche principali dei motoriduttori brushless CC pendolari della serie BLFT sono:

The main features of BLFT brushless DC helical parallel gearmotors range are:

- Alimentazione in bassa tensione 24/36/48 Vcc
- Motore Brushless CC con grado di protezione IP55
- Coppie motori disponibili da 0.22 Nm a 0.43 Nm
- Lubrificazione permanente con olio sintetico
- Carcassa in pressofusione di alluminio
- Ingranaggi cilindrici a denti elicoidali, induriti e rettificati
- Disponibili anche nella versione con solo riduttore, sia con flangia di entrata standard che con flangia e manicotto dedicati

- Low voltage power supply 24/36/48 Vdc
- Brushless DC motor in IP55 protection Standard
- Motor torque ratings available from 0.22 Nm up to 0.43 Nm
- Permanent synthetic oil long life lubrication
- Die-cast aluminium housing
- Ground-hardened helical gears
- Gearbox only version also available, with either standard input flange or customized flange and coupling

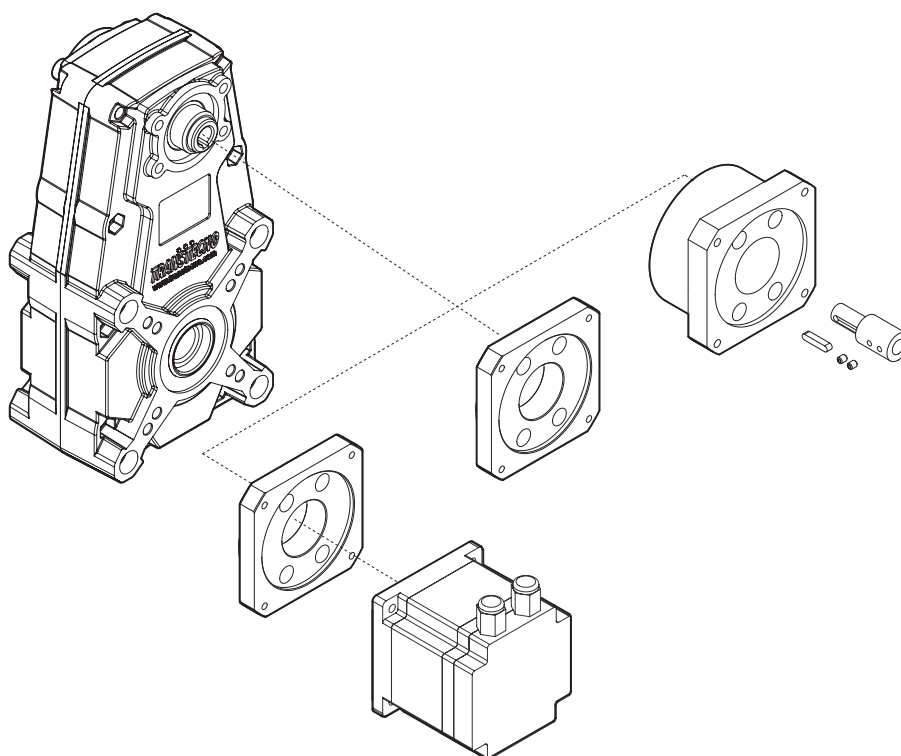

Designazione

Classification

RIDUTTORE / GEARBOX					MOTORE / MOTOR		
FT	105	U	46	020	BL043.240	24V	BR
Tipo Type	Grandezza Size	Versione riduttore Gearbox version	Rapporto Ratio	Albero di uscita Output shaft	Tipo Type	Tensione Voltage	Freno Brake
FT	105	U	Vedere tabelle See tables	Vedere tabelle See tables	BLS022.240 BLS043.240	24V - 36V 24V - 36V	24V 48V





Simbologia

Symbols

Ns	n° stadi / No. stages	Mn ₂	[Nm]	Coppia nominale in uscita in funzione di Pn1 <i>Nominal output torque referred to Pn1</i>
ir	rapporto reale / real ratio	n _{1MAX}	[Rpm]	Velocità max entrata / Max input speed
M ₂	[Nm]	V	[V]	Tensione / Voltage
A ₂	[N]	n ₂	[Rpm]	Velocità in uscita / Output Speed
R ₂	[N]	IP		Grado di protezione / Enclosure protection
Pn ₁	[kW]	Kg		Peso / Weight
		sf		Fattore di servizio / Service Factor

Lubrificazione e temperatura

Lubrication and temperature

I motoriduttori BLFT sono forniti completi di lubrificante sintetico (viscosità 320) e non necessitano di manutenzione. Temperatura ambiente 0 ÷ 40 °C (in assenza di congelamento ed in assenza di condensa). Per temperature diverse, contattare nostro UT.

Permanent synthetic oil long life lubrication (viscosity grade 320) on BLFT gearmotors. Ambient temperature 0 ÷ 40 °C (in the absence of freezing and condensation). For temperature outside this range please contact our technical dept.

Carichi radiali

Radial loads

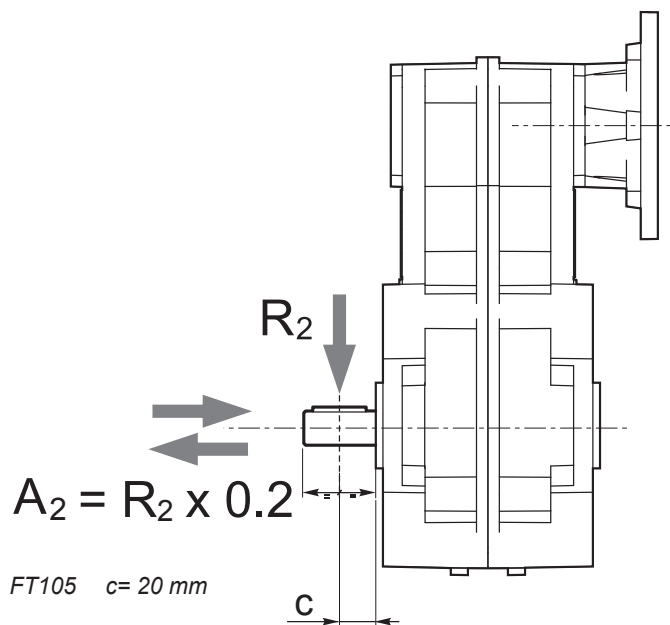

n ₂ [min ⁻¹]	R ₂ [N]
	FT105
70	1500
40	1700
30	1850
20	2000
10	2000
5	2000

Quando il carico radiale risultante non è applicato sulla mezza-ria dell'albero occorre calcolare quello effettivo con la seguente formula:

When the resulting radial load is not applied on the centre line of the shaft it is necessary to calculate the effective load with the following formula:

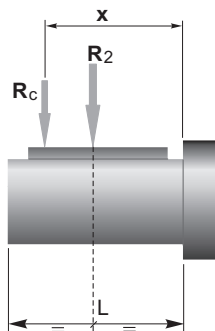

	FT105
a	82
b	62
R _{2MAX}	2000

$$R_c = \frac{R_2 \cdot a}{(b+x)} \leq R_{2MAX}$$

$$R \leq R_c$$

a, b = valori riportati nella tabella
a, b = values given in the table



FT105 con motore brushless

FT105 with brushless motor

FT105		BLS043.240													
		24V						36V							
		n _{2MIN} [rpm]			n _{2MAX} [rpm]			n _{1MAX} [rpm]	n _{2MIN} [rpm]			n _{2MAX} [rpm]		n _{1MAX} [rpm]	
M ₂ [Nm]	sf	M ₂ [Nm]	sf	M ₂ [Nm]	sf	M ₂ [Nm]	sf		M ₂ [Nm]	sf					
20.6	3	14.6	8.3	5.5	146	8.3	3.8	3000	19.4	8.3	5.5	194	8.3	3.3	4000
33.3		9.0	13	4.3	90	13	2.9		12.0	13	4.3	120	13	2.6	
44.4		6.8	18	4.2	68	18	2.8		9.0	18	4.2	90	18	2.5	
54.9		5.5	22	3.4	55	22	2.3		7.3	22	3.4	73	22	2.0	
71.8		4.2	29	2.6	42	29	1.7		5.6	29	2.6	56	29	1.5	
77.1		3.9	31	2.4	39	31	1.6		5.2	31	2.4	52	31	1.4	
88.9		3.4	36	2.1	34	36	1.4		4.5	36	2.1	45	36	1.2	
124.8		2.4	50	1.5	24	50	1.0		3.2	50	1.5	32	50	0.9	
181.4		1.7	73	1.0	17	72	0.7		2.2	73	1.0	22	64	0.7	
224.3		1.3	91	0.8	13	72	0.7		1.8	91	0.8	18	64	0.7	
315.1		1.0	105	0.7	10	72	0.7		1.3	105	0.7	13	64	0.7	
368.2		0.8	105	0.7	8.1	72	0.7		1.1	105	0.7	11	64	0.7	
535.0		0.6	105	0.7	5.6	72	0.7		0.7	105	0.7	7.5	64	0.7	
661.8	0.5	105	0.7	4.5	72	0.7	0.6	105	0.7	6.0	64	0.7			
929.4	0.3	105	0.7	3.2	72	0.7	0.4	105	0.7	4.3	64	0.7			

NOTA: per servizio continuo o altamente intermittente, contattare il servizio tecnico

NOTE: for continuous or highly intermittent duty, please contact our technical service

Attenzione: superamento della coppia nominale supportata dal riduttore per servizio S1. Contattare il ns. servizio tecnico
Attention: rated torque withstood by gear reducer for service in S1 is exceeded. Please, contact our technical office.

Tipo Type	Numero di poli Number of poles	Numero di fasi Number of phase	Tensione Rated voltage [V]	Numero di giri Rated speed [rpm]	Coppia nominale Rated torque [Nm]	Potenza nominale Rated power [W]
BLS043.240	4	3	36	4000	0.43	180
			24	3000		130
Tipo Type	Coppia massima Peak torque [Nm]	Corrente nominale Rated current [A]	Resistenza Resistance [ohm]	Induttanza Inductance [mH]	Corrente massima Peak current [A]	Peso Weight [kg]
BLS043.240	0.86	6	0.35	1	12.0	1.25

Azionamenti Drives

CF2

FT105U + BLS043.240

CC6

FT105.. AS...

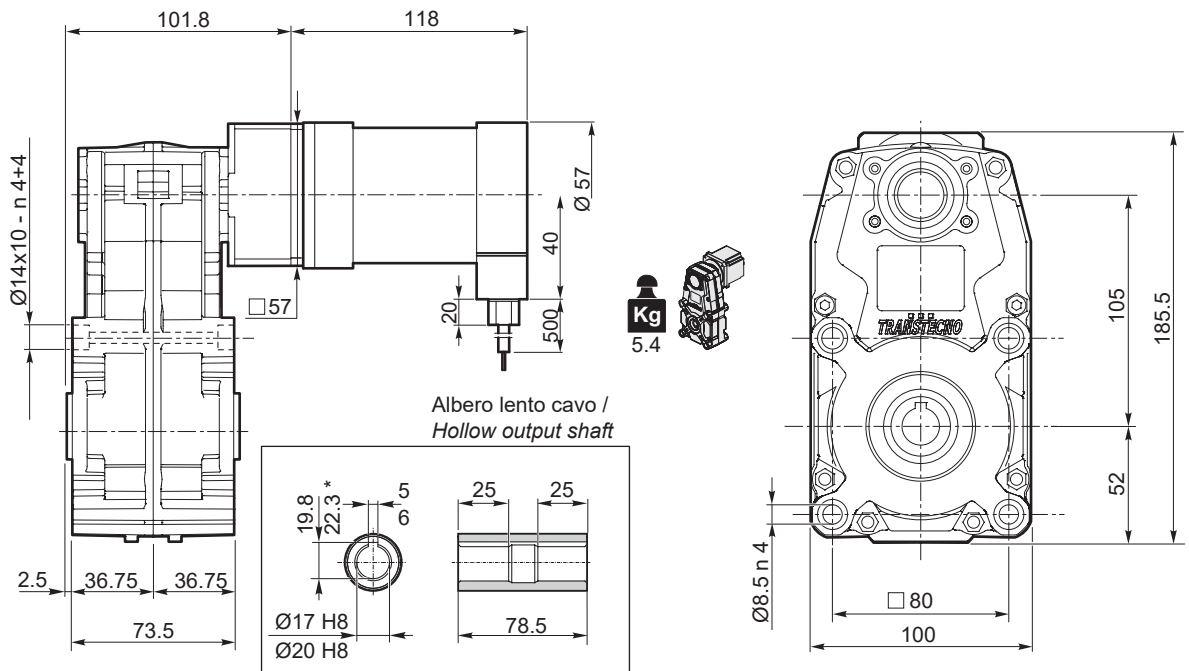



*Sede linguetta ribassata /
*Special keyway



Dati tecnici

Technical data

	n_2 [min ⁻¹]	Mn_2 [Nm]	Pn_1 [kW]	i
FT105				
n1 = 1400 rpm	68	40	0.30	20.57
	42	50	0.23	33.32
	32		0.23	44.36
	26		0.18	54.87
	20		0.14	71.84
	18		0.13	77.07
	16	65	0.11	88.87
	11		0.081	124.81
	7.7		0.056	181.35
	6.2		0.045	224.32
FT105/3	4.4		0.032	315.05
	3.8	65	0.028	368.19
	2.6		0.019	534.98
	2.1		0.015	661.76
1.5	0.011		929.40	

	n_2 [min ⁻¹]	Mn_2 [Nm]	Pn_1 [kW]	i
FT105				
n1 = 3000 rpm	146	31	0.51	20.57
	90	39	0.39	33.32
	68		0.38	44.36
	55		0.31	54.87
	42		0.24	71.84
	39		0.22	77.07
	34	51	0.19	88.87
	24		0.14	124.81
	17		0.09	181.35
	13		0.08	224.32
FT105/3	10		0.05	315.05
	8.1	51	0.05	368.19
	5.6		0.03	534.98
	4.5		0.03	661.76
3.2	0.02		929.40	

NOTA: per servizio continuo o altamente intermittente, contattare il servizio tecnico

NOTE: for continuous or highly intermittent duty, please contact our technical service

Dimensioni FT con flange motore AS

FT dimensions with motor flanges AS

FT105 - U - AS...

Lo spessore della flangia è variabile in funzione delle diverse lunghezze dell'albero motore.

Flange's thickness may vary depending on motor shaft's length.

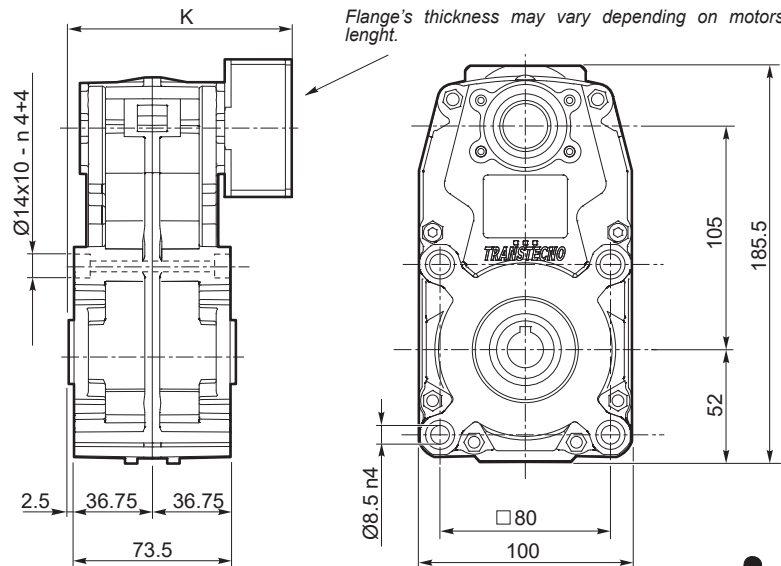
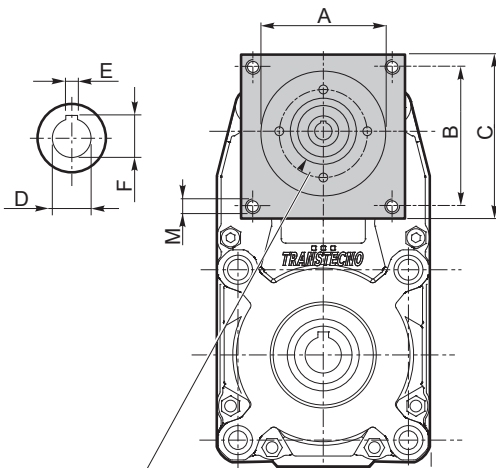

Connessione con boccia o giunto in funzione del diametro dell'albero motore.

Connection with sleeve or coupling depending on motor shaft's diameter.

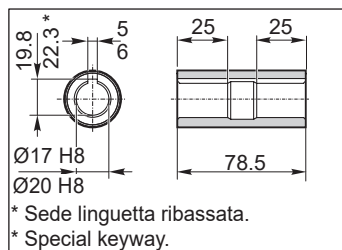

Albero lento cavo / Hollow output shaft

Kg
4.2

Dimensioni / Dimensions								
AS	A	B	C	M	K	D	E	F
AS416	38.1	47.1	56.6	M5	101.8	9	3	10.4
...

MINI  **TECNO**™
small but strong

BLCM

Motoriduttori brushless CC a vite senza fine
Brushless DC wormgearmotors

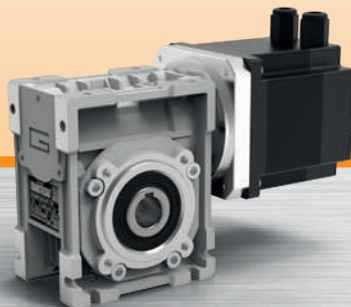

MINI  **TECNO**™ brand of
TRANSTECNO®



BLDC

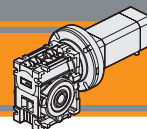

Indice	Index	Pag. Page
Caratteristiche tecniche	<i>Technical features</i>	CD2
Designazione	<i>Classification</i>	CD2
Simbologia	<i>Symbols</i>	CD3
Lubrificazione e temperatura	<i>Lubrication and temperature</i>	CD3
Carichi radiali	<i>Radial loads</i>	CD3
Dati di dentatura	<i>Toothing data</i>	CD4
Rendimento	<i>Efficiency</i>	CD4
Rerersibilità e irreversibilità	<i>Reversibility and irreversibility</i>	CD4
CM026 con motore brushless BLS 022.240	<i>CM026 with brushless motor BLS 022.240</i>	CD5
CM030 con motore brushless BLS 043.240	<i>CM030 with brushless motor BLS 043.240</i>	CD6
CM030 con motore brushless BL 070.240	<i>CM030 with brushless motor BL 070.240</i>	CD7
CM030 con motore brushless BL 070.24B	<i>CM030 with brushless motor BL 070.24B</i>	CD7
CM030 con motore brushless BL 070.480	<i>CM030 with brushless motor BL 070.480</i>	CD7
CM030 con motore brushless BL 070.48B	<i>CM030 with brushless motor BL 070.48B</i>	CD7
CM040 con motore brushless BLS 043.240	<i>CM040 with brushless motor BLS 043.240</i>	CD8
CM040 con motore brushless BL 070.240	<i>CM040 with brushless motor BL 070.240</i>	CD9
CM040 con motore brushless BL 070.24B	<i>CM040 with brushless motor BL 070.24B</i>	CD9
CM040 con motore brushless BL 070.480	<i>CM040 with brushless motor BL 070.480</i>	CD9
CM040 con motore brushless BL 070.48B	<i>CM040 with brushless motor BL 070.48B</i>	CD9
CM040 con motore brushless BL 140.480	<i>CM040 with brushless motor BL 140.480</i>	CD9
CM040 con motore brushless BL 210.480	<i>CM040 with brushless motor BL 210.480</i>	CD9
CM040 con motore brushless BL 210.48E	<i>CM040 with brushless motor BL 210.48E</i>	CD9
Dati tecnici	<i>Technical data</i>	CD10
Dimensioni CM con flange motore AS	<i>CM dimensions with motor flanges AS</i>	CD11
Dimensioni flange uscita	<i>Output flange dimensions</i>	CD13
Opzioni	<i>Options</i>	CD14
Accessori	<i>Accessories</i>	CD14

Questa sezione annulla e sostituisce ogni precedente edizione o revisione. Qualora questa sezione non Vi sia giunta in distribuzione controllata, l'aggiornamento dei dati ivi contenuto non è assicurato. **In tal caso la versione più aggiornata è disponibile sul nostro sito internet www.transtecno.com**

This section replaces any previous edition and revision. If you obtained this catalogue other than through controlled distribution channels, the most up to date content is not guaranteed. In this case the latest version is available on our web site www.transtecno.com

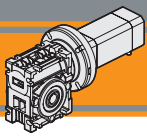

Caratteristiche tecniche

Technical features

Le caratteristiche principali dei motoriduttori brushless CC a vite senza fine della serie BLCM sono:

The main features of BLCM brushless DC wormgearmotors range are:

- Alimentazione in bassa tensione 24/36/48 Vcc
- Motore Brushless CC con grado di protezione IP55
- Coppie motore disponibili da 0.22 a 2.1 Nm
- Carcasse dei riduttori in pressofusione di alluminio
- Lubrificazione permanente con olio sintetico
- Disponibili anche nella versione con solo riduttore, sia con flangia di entrata standard che con flangia e manicotto dedicati
- Low voltage power supply 24/36/48 Vdc
- Brushless DC motor in IP55 protection Standard
- Motor torque ratings available from 0.22 up to 2.1 Nm
- Die-cast aluminium housings
- Permanent synthetic oil long life lubrication
- Gearbox only version also available, with either standard input flange or customized flange and coupling

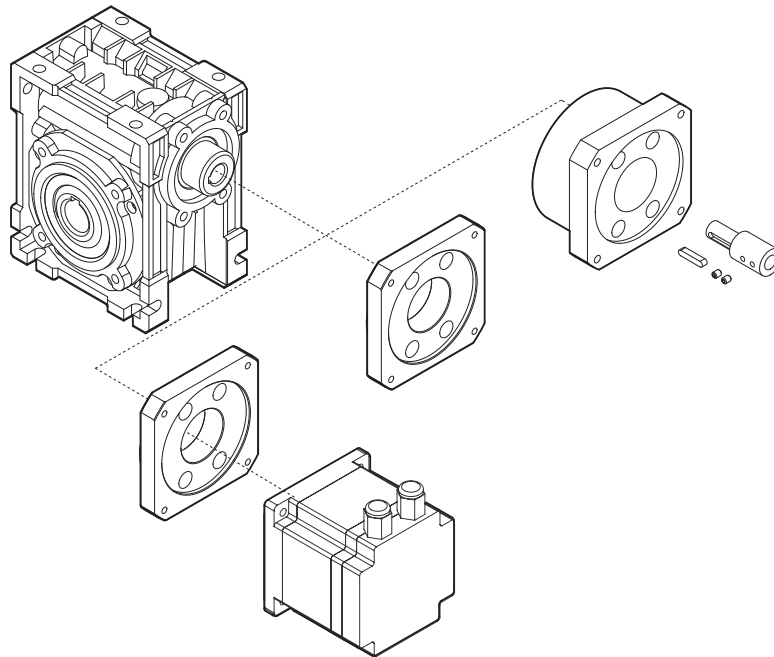

Designazione

Classification

RIDUTTORE / GEARBOX				MOTORE / MOTOR		
CM	030	20	U	BL070.480	48V	BR
Tipo Type	Grandezza Size	Rapporto in Ratio in	Versione Version	Tipo Type	Tensione Voltage	Freno Brake
CM	026 026 (11) 026 (14) 030 040	Vedere tabelle See tables	U F FL FB	BLS022.240 BLS043.240 BL070.240 BL070.24B BL070.48B BL070.480 BL140.480 BL210.480 BL210.48E	24V-36V 24V-36V 24V 24V 48V 48V 48V 48V	24V 48V

Versione Riduttore
Gearbox Version

Albero di uscita
Output shaft

Braccio di reazione
Torque arm

Angolo
Angle

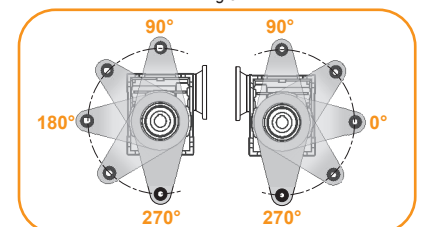
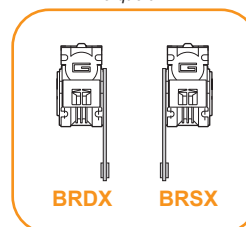
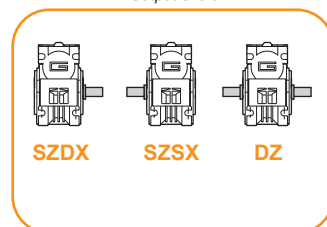
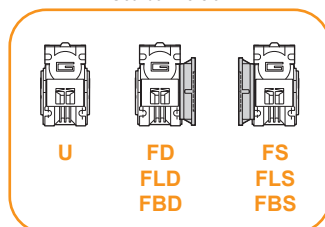

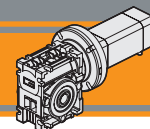

Simbologia

Symbols

Ns	n° stadi / No. stages	n _{1MAX}	[Rpm]	Velocità max entrata / Max input speed
ir	rapporto reale / real ratio	V	[V]	Tensione / Voltage
M ₂	[Nm] coppia in uscita / output torque	n ₂	[Rpm]	Velocità in uscita / Output Speed
A ₂	[N] Carico assiale ammissibile in uscita / Permitted output axial load	IP		Grado di protezione / Enclosure protection
R ₂	[N] Carico radiale ammissibile in uscita / Permitted output radial load	Kg		Peso / Weight
Pn ₁	[kW] Potenza nominale in entrata / Nominal input power	sf		Fattore di servizio / Service Factor
Mn ₂	[Nm] Coppia nominale in uscita in funzione di Pn1 / Nominal output torque referred to Pn1	Rd	%	Rendimento dinamico / Dynamic efficiency
		Rs	%	Rendimento statico / Static efficiency
		Z		Numero di principi della vite / Worm starts
		β		Angolo d'elica / Helix angle

Lubrificazione e temperatura

Lubrication and temperature

Tutti i motoriduttori BLCM sono forniti completi di lubrificante sintetico viscosità 320, pertanto possono essere installati in qualunque posizione di montaggio e non necessitano di manutenzione.

Permanent synthetic oil long-life lubrication (viscosity grade 320) makes it possible to use the BLCM worm gearmotors in all mounting positions; for this reason they can be installed in any assembly position and do not require maintenance.

Temperatura ambiente 0 ÷ 40 °C (in assenza di congelamento ed in assenza di condensa).

Ambient temperature 0 ÷ 40 °C (in the absence of freezing and condensation).

Per temperature diverse, contattare nostro UT.

For temperature outside this range please contact our technical dept.

Carichi radiali

Radial loads

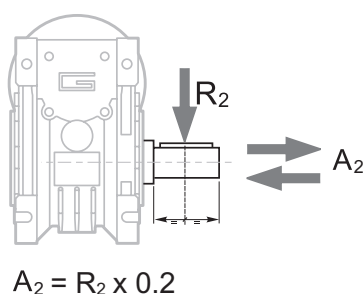

n ₂ [min ⁻¹]	R ₂ [N]		
	CM026	CM030	CM040
187	400	674	1264
140	490	743	1392
93	480	851	1596
70	610	936	1754
56	610	1008	1890
47	610	1069	2004
35	610	1179	2210
28	610	1270	2381
23	610	1356	2542
18	610	1471	2759
14	610	1600	3000

Quando il carico radiale risultante non è applicato sulla mezzeria dell'albero occorre calcolare quello effettivo con la seguente formula:

When the resulting radial load is not applied on the centre line of the shaft it is necessary to calculate the effective load with the following formula:

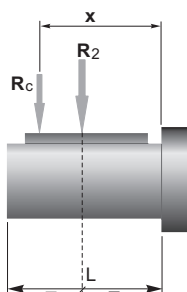

	CM		
	026	030	040
a	56	65	84
b	43	50	64
R _{2MAX}	610	1600	3000

$$R_c = \frac{R_2 \cdot a}{(b+x)} \leq R_{2MAX}$$

$$R \leq R_c$$

a. b = valori riportati nella tabella
a. b = values given in the table

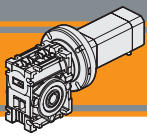

Dati di dentatura

Toothing data

	Dati della coppia vite-corona Worm wheel data	Rapporto / Ratio											
		5	7.5	10	15	20	25	30	40	50	60	80	100
CM026	Z	6	4	3	2	2		1	1	1	1		
	β	34° 35'	24° 41'	19° 1'	12° 57'	10° 30'		6° 33'	5° 17'	4° 26'	3° 49'		
CM030	Z	6	4	3	2	2	2	1	1	1	1	1	1
	β	27° 4'	24° 28'	18° 50'	12° 49'	10° 23'	8° 43'	6° 29'	5° 14'	4° 23'	3° 46'	2° 57'	2° 25'
CM040	Z	6	4	3	2	2	2	1	1	1	1	1	1
	β	34° 19'	24° 28'	18° 50'	12° 49'	10° 23'	8° 43'	6° 29'	5° 14'	4° 23'	3° 46'	2° 57'	2° 25'

Rendimento

Efficiency

	n_1 [min ⁻¹]	Rendimento Efficiency	Rapporto / Ratio											
			5	7.5	10	15	20	25	30	40	50	60	80	100
CM026	2800	Rd	89	87	85	83	80		73	68	64	60		
		Rs	72	71	68	61	56	46	41	36	34			
CM030	2800	Rd	89	88	86	84	81	78	74	70	65	62	57	52
		Rs	72	67	63	55	50	43	39	35	31	27	23	21
CM040	2800	Rd	90	89	87	84	83	80	77	73	69	66	60	56
		Rs	74	71	67	60	55	51	45	40	36	32	28	24

Reversibilità e irreversibilità

Reversibility and irreversibility

La tabella sottostante riporta a titolo puramente indicativo i vari gradi di reversibilità/irreversibilità nei riduttori a vite senza fine in funzione del rendimento dinamico Rd e statico Rs.

The table below is provided for reference purposes only. It contains the various degrees of reversibility/irreversibility of wormgearboxes in relation to dynamic Rd and static Rs efficiency.

Rd	Reversibilità e irreversibilità dinamica	Dynamic reversibility and irreversibility
> 0.60	Reversibilità dinamica	Dynamic reversibility
0.50 - 0.60	Reversibilità dinamica incerta	Uncertain dynamic reversibility
0.40 - 0.50	Buona irreversibilità dinamica	Good dynamic irreversibility
<0.40	Irreversibilità dinamica	Dynamic irreversibility
Rs	Reversibilità e irreversibilità statica	Static reversibility and irreversibility
> 0.55	Reversibilità statica	Static reversibility
0.50 - 0.55	Reversibilità statica incerta	Uncertain static reversibility
<0.50	Irreversibilità statica	Static irreversibility

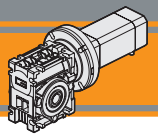

CM026 con motore brushless

CM026 with brushless motor

CM026	BLS022.240													
	24V						36V							
	n ₂ MIN		n ₂ MAX		n ₁ MAX [rpm]	n ₂ MIN		n ₂ MAX		n ₁ MAX [rpm]				
M ₂	sf	M ₂	sf	M ₂		sf	M ₂	sf						
5	60	0.9	27	600	1.0	10	3000	80	0.9	21	800	1.0	8.0	4000
7.5	40	1.3	19	400	1.5	7.9		53	1.3	16	533	1.5	6.0	
10	30	1.7	16	300	1.9	5.8		40	1.7	12	400	1.9	4.7	
15	20	2.2	12	200	2.7	4.1		27	2.3	9.1	267	2.8	3.2	
20	15	2.8	9.3	150	3.5	3.1		20	2.9	6.9	200	3.6	2.5	
30	10	3.6	7.5	100	4.8	2.5		13	3.8	5.8	133	5.0	2.0	
40	7.5	4.4	4.8	75	6.0	1.8		10	4.6	4.1	100	6.2	1.5	
50	6	4.8	4.2	60	7.0	1.4		8.0	5.2	3.5	80	7.3	1.1	
60	5	5.4	3.3	50	7.8	1.1		6.7	5.8	2.9	67	8.2	0.9	

NOTA: per servizio continuo o altamente intermittente, contattare il servizio tecnico

NOTE: for continuous or highly intermittent duty, please contact our technical service

Attenzione: superamento della coppia nominale supportata dal riduttore per servizio S1. Contattare il ns. servizio tecnico
Attention: rated torque withstood by gear reducer for service in S1 is exceeded. Please, contact our technical office.

Tipo Type	Numero di poli Number of poles	Numero di fasi Number of phase	Tensione Rated voltage [V]	Numero di giri Rated speed [rpm]	Coppia nominale Rated torque [Nm]	Potenza nominale Rated power [W]
BLS022.240	4	3	36	4000	0.22	92
			24	3000		70
Tipo Type	Coppia massima Peak torque [Nm]	Corrente nominale Rated current [A]	Resistenza Resistance [ohm]	Induttanza Inductance [mH]	Corrente massima Peak current [A]	Peso Weight [kg]
BLS022.240	0.44	3.7	0.64	3.1	7.4	0.72

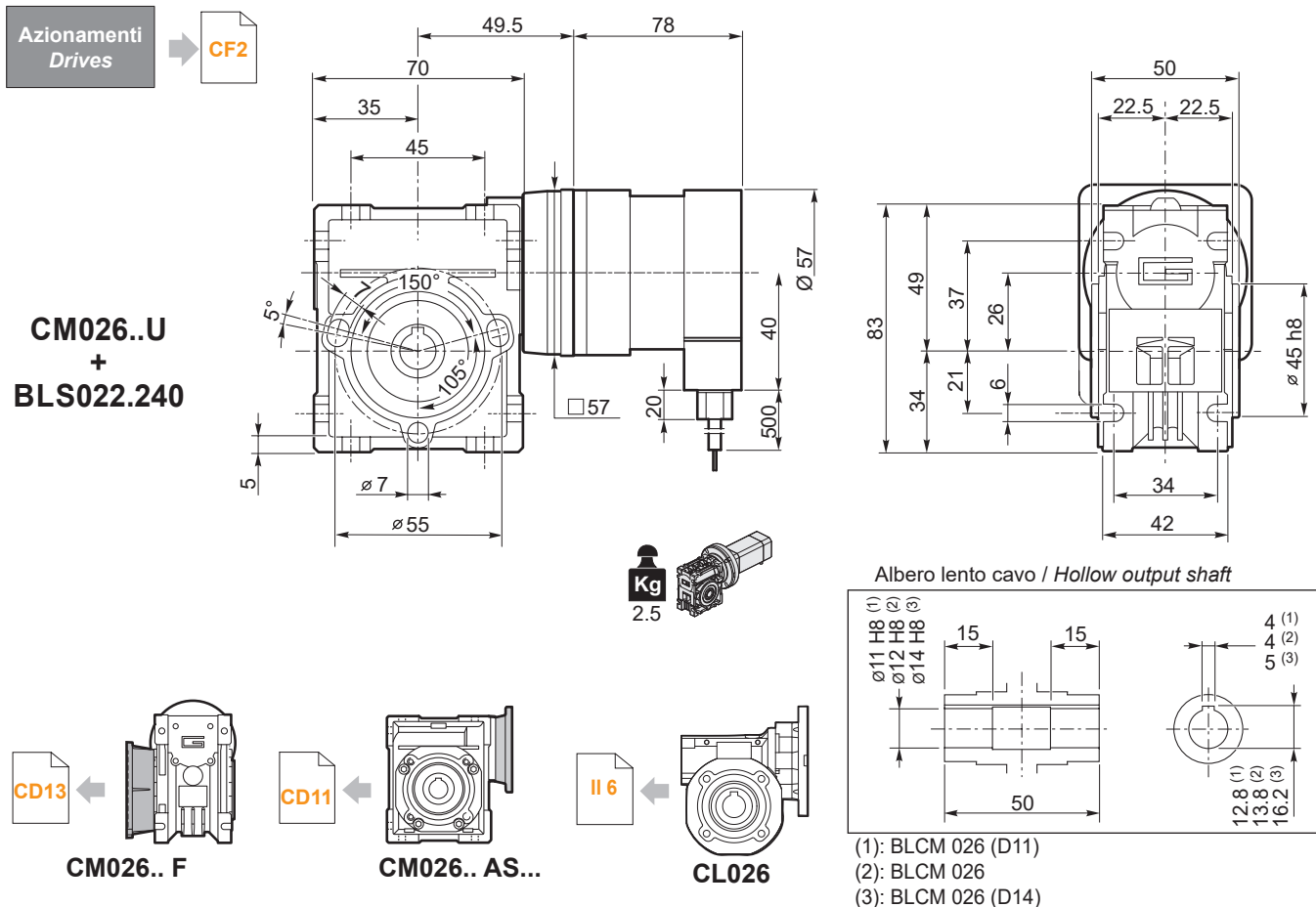

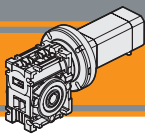

CM030 con motore brushless

CM030 with brushless motor

CM030	BLS043.240													
	24V						36V							
	n ₂ MIN		sf		n ₂ MAX		n ₁ MAX [rpm]	n ₂ MIN		n ₂ MAX		n ₁ MAX [rpm]		
M ₂				M ₂		M ₂								
5	60	1.7	20	600	1.9	6.8	3000	80	1.7	20	800	1.9	6.8	4000
7.5	40	2.5	14	400	2.8	5.3		53	2.5	14	533	2.8	5.3	
10	30	3.2	12	300	3.7	4.3		40	3.2	12	400	3.7	4.3	
15	20	4.4	8.6	200	5.4	3.0		26	4.4	8.6	267	5.4	3.0	
20	15	5.5	5.8	150	7.0	2.0		20	5.5	5.8	200	7.0	2.0	
25	12	6.5	4.8	120	8.4	1.8		16	6.5	4.8	160	8.4	1.8	
30	10	7.1	5.5	100	9.5	1.9		13	7.1	5.5	133	9.5	1.9	
40	7.5	8.4	3.9	75	12	1.3		10	8.4	3.9	100	12	1.3	
50	6.0	9.7	3.0	60	14	1.1		8	9.7	3.0	80	14	1.1	
60	5.0	11	2.5	50	16	0.9		6.6	11	2.5	67	16	0.9	
80	3.7	12	1.8	38	17	0.7		5	12	1.8	50	17	0.7	
100	3.0	14	1.4	30	16	0.7		4	14	1.4	40	16	0.7	

NOTA: per servizio continuo o altamente intermittente, contattare il servizio tecnico

NOTE: for continuous or highly intermittent duty, please contact our technical service



Attenzione: superamento della coppia nominale supportata dal riduttore per servizio S1. Contattare il ns. servizio tecnico
Attention: rated torque withstood by gear reducer for service in S1 is exceeded. Please, contact our technical office.

Tipo Type	Numero di poli Number of poles	Numero di fasi Number of phase	Tensione Rated voltage [V]	Numero di giri Rated speed [rpm]	Coppia nominale Rated torque [Nm]	Potenza nominale Rated power [W]
BLS043.240	4	3	36	4000	0.43	180
	4	3	24	3000	0.43	130
Tipo Type	Coppia massima Peak torque [Nm]	Corrente nominale Rated current [A]	Resistenza Resistance [ohm]	Induttanza Inductance [mH]	Corrente massima Peak current [A]	Peso Weight [kg]
BLS043.240	0.86	6	0.35	1.0	12.0	1.25

Azionamenti Drives



CM030..U
+
BLS043.240

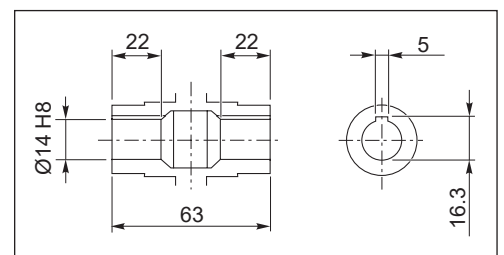
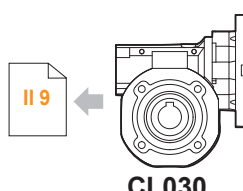
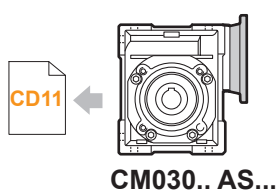
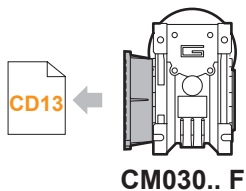
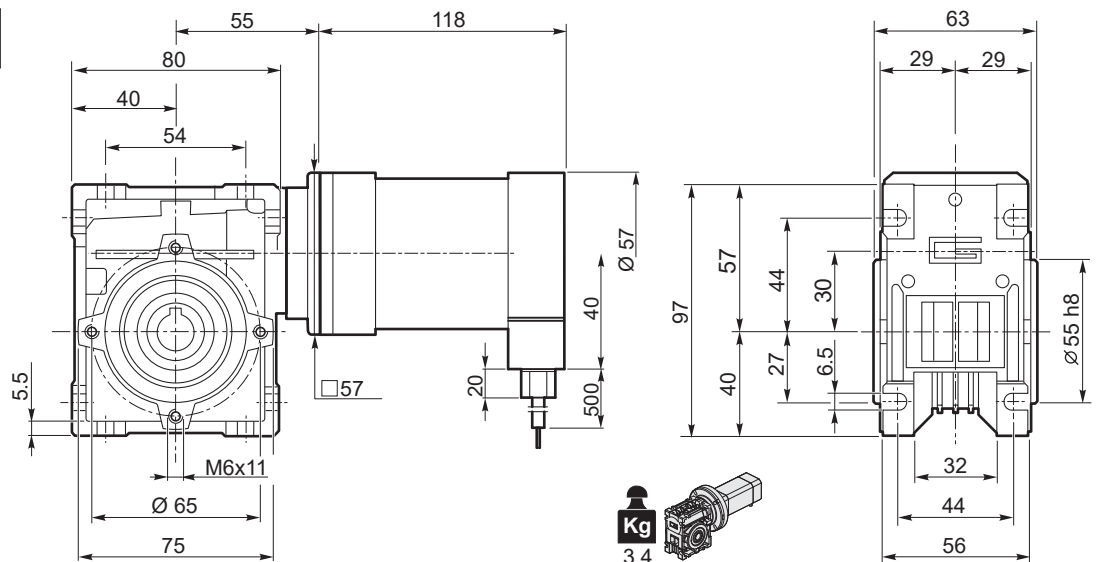

Albero lento cavo / Hollow output shaft

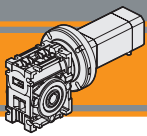

CM040 con motore brushless

CM040 with brushless motor

CM040	BLS043.240											
	24V						36V					
	n ₂ MIN		sf	n ₂ MAX		n ₁ MAX [rpm]	n ₂ MIN		sf	n ₂ MAX		n ₁ MAX [rpm]
M ₂		M ₂			M ₂			M ₂				
5	60	1.8	35	600	2.0	14	80	1.8	35	800	2.0	14
7.5	40	2.6	26	400	2.9	11	53	2.6	26	533	2.9	11
10	30	3.4	20	300	3.7	8.9	40	3.4	20	400	3.7	8.9
15	20	4.6	15	200	5.4	6.5	26	4.6	15	267	5.4	6.5
20	15	5.8	10	150	7.2	4.3	20	5.8	10	200	7.2	4.3
25	12	6.9	7.8	120	8.6	3.2	16	6.9	7.8	160	8.6	3.2
30	10	7.9	9.4	100	10	3.8	13	7.9	9.4	133	10	3.8
40	7.5	9.6	6.8	75	13	2.6	10	9.6	6.8	100	13	2.6
50	6.0	12	5.5	60	15	2.1	8	12	5.5	80	15	2.1
60	5.0	12	4.7	50	17	1.7	6.6	12	4.7	67	17	1.7
80	3.7	14	3.6	38	21	1.3	5	14	3.6	50	21	1.3
100	3.0	16	2.8	30	24	1.0	4	16	2.8	40	24	1.0

NOTA: per servizio continuo o altamente intermittente, contattare il servizio tecnico

NOTE: for continuous or highly intermittent duty, please contact our technical service

Tipo Type	Numero di poli Number of poles	Numero di fasi Number of phase	Tensione Rated voltage [V]	Numero di giri Rated speed [rpm]	Coppia nominale Rated torque [Nm]	Potenza nominale Rated power [W]
BLS043.240	4	3	36	4000	0.43	180
	4	3	24	3000	0.43	130
Tipo Type	Coppia massima Peak torque [Nm]	Corrente nominale Rated current [A]	Resistenza Resistance [ohm]	Induttanza Inductance [mH]	Corrente massima Peak current [A]	Peso Weight [kg]
BLS043.240	0.86	6	0.35	1.0	12.0	1.25

Azionamenti Drives



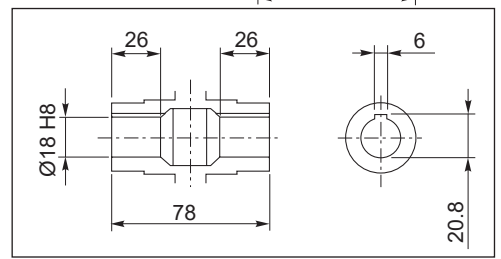
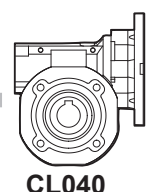
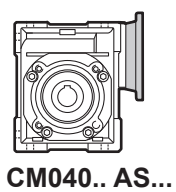
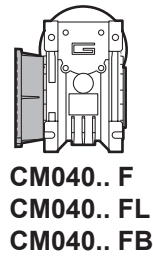
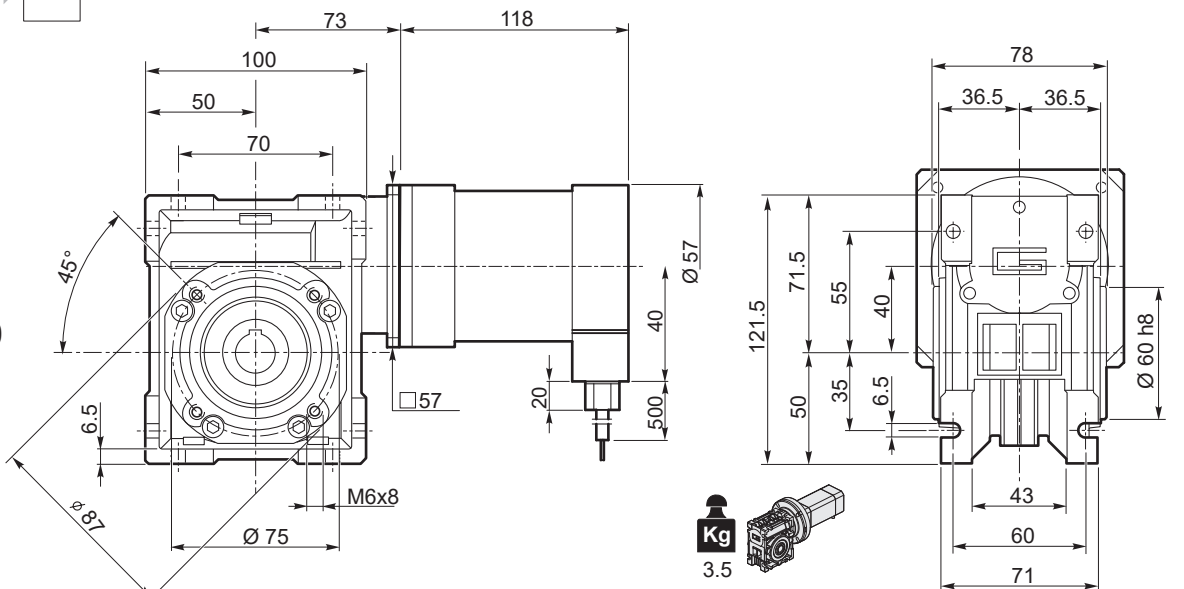

CM040..U + BLS043.240

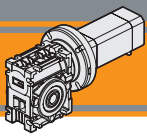

Albero lento cavo / Hollow output shaft

**Dati tecnici****Technical data**

	n_2 [min ⁻¹]	Mn_2 [Nm]	Pn_1 [kW]	i
---	-------------------------------	----------------	----------------	-----

	n_2 [min ⁻¹]	Mn_2 [Nm]	Pn_1 [kW]	i
---	-------------------------------	----------------	----------------	-----

CM026

$n_1 = 1400 \text{ rpm}$	n_2	Mn_2	Pn_1	i
	280	13	0.44	5
	187	14	0.33	7,5
	140	14	0.25	10
	93	14	0.18	15
	70	14	0.14	20
	47	15	0.11	30
	35	14	0.08	40
	28	13	0.07	50
	23	12	0.06	60

CM026

$n_1 = 3000 \text{ rpm}$	n_2	Mn_2	Pn_1	i
	600	10	0.71	5
	400	11	0.53	7,5
	300	11	0.41	10
	200	11	0.28	15
	150	11	0.22	20
	100	12	0.17	30
	75	11	0.13	40
	60	10	0.10	50
	50	9	0.08	60

CM030

$n_1 = 1400 \text{ rpm}$	n_2	Mn_2	Pn_1	i
	280	18	0.61	5
	187	20	0.46	7,5
	140	21	0.37	10
	93	21	0.26	15
	70	19	0.19	20
	56	20	0.16	25
	47	22	0.16	30
	35	20	0.12	40
	28	19	0.10	50
	23	17	0.08	60
	18	15	0.06	80
	14	14	0.05	100

CM030

$n_1 = 3000 \text{ rpm}$	n_2	Mn_2	Pn_1	i
	600	13	0.92	5
	400	15	0.71	7,5
	300	16	0.58	10
	200	16	0.40	15
	150	14	0.27	20
	120	15	0.24	25
	100	18	0.25	30
	75	16	0.18	40
	60	15	0.14	50
	50	14	0.12	60
	37.5	12	0.08	80
	30	11	0.07	100

CM040

$n_1 = 1400 \text{ rpm}$	n_2	Mn_2	Pn_1	i
	280	41	1.37	5
	187	44	1.00	7,5
	140	45	0.79	10
	93	45	0.54	15
	70	40	0.38	20
	56	38	0.30	25
	47	48	0.34	30
	35	42	0.24	40
	28	39	0.19	50
	23	36	0.15	60
	18	33	0.12	80
	14	31	0.10	100

CM040

$n_1 = 3000 \text{ rpm}$	n_2	Mn_2	Pn_1	i
	600	29	2.02	5
	400	31	1.46	7,5
	300	33	1.19	10
	200	35	0.87	15
	150	31	0.59	20
	120	28	0.44	25
	100	38	0.52	30
	75	34	0.37	40
	60	32	0.29	50
	50	29	0.23	60
	37.5	27	0.18	80
	30	24	0.13	100

NOTA: per servizio continuo o altamente intermittente, contattare il servizio tecnico

NOTE: for continuous or highly intermittent duty, please contact our technical service

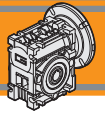

Dimensioni CM con flange motore AS

CM dimensions with motor flanges AS

CM026 - U - AS...

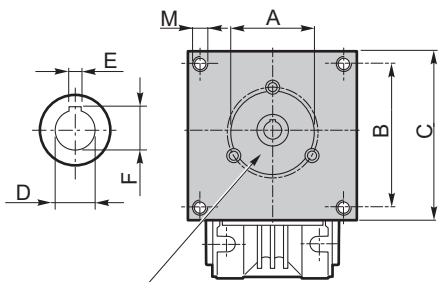

Connessione con boccola o giunto in funzione del diametro dell'albero motore.

Connection with sleeve or coupling depending on motorshaft's diameter.

Albero lento cavo / Hollow output shaft

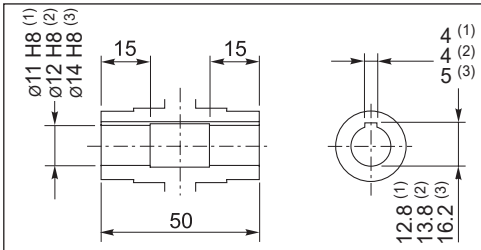

- (1): BLCM 026 (D11)
- (2): BLCM 026
- (3): BLCM 026 (D14)

Lo spessore della flangia è variabile in funzione delle diverse lunghezze dell'albero motore.

Flange's thickness may vary depending on motorshaft's lenght.

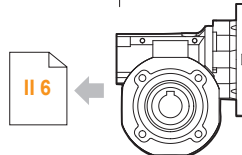
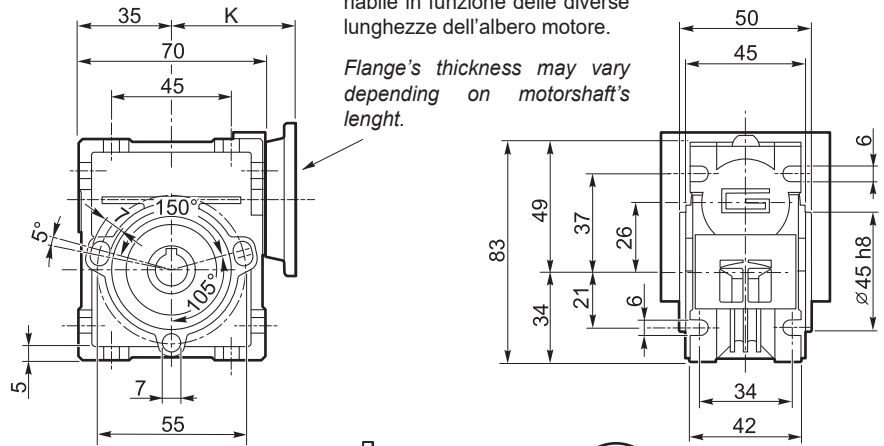

CL026

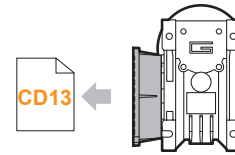

CM026.. F

Kg
0.8

Dimensioni / Dimensions						Rapporti / Ratio		
AS	A	B	C	M	K	5...100		
						D	E	F
AS417	38.1	47.1	56	M4	49.5	9	3	10.4
...

CM030 - U - AS...

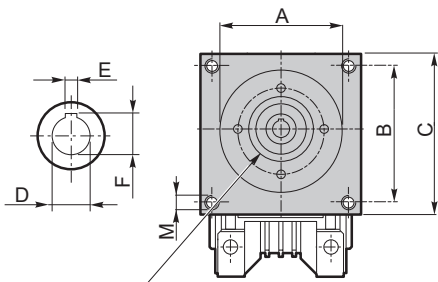

Connessione con boccola o giunto in funzione del diametro dell'albero motore.

Connection with sleeve or coupling depending on motorshaft's diameter.

Lo spessore della flangia è variabile in funzione delle diverse lunghezze dell'albero motore.

Flange's thickness may vary depending on motorshaft's lenght.

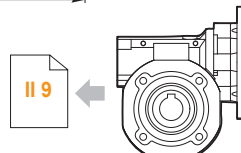
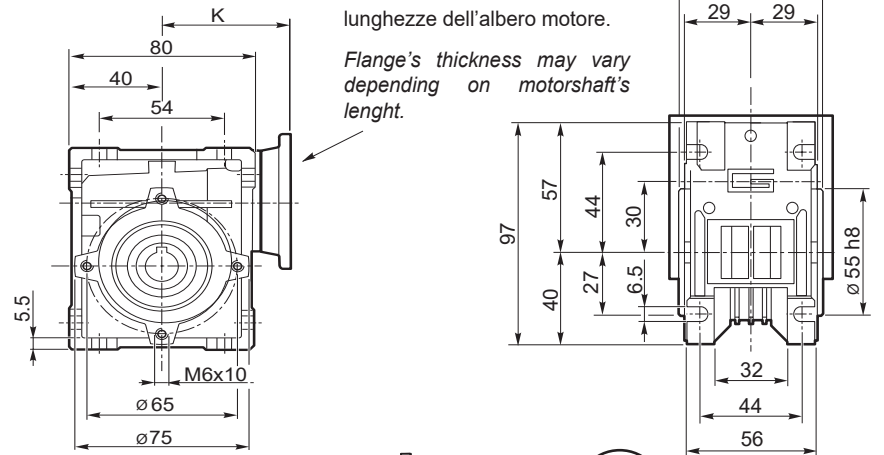

CL030

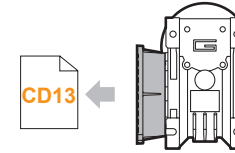

CM030.. F

Kg
1.2

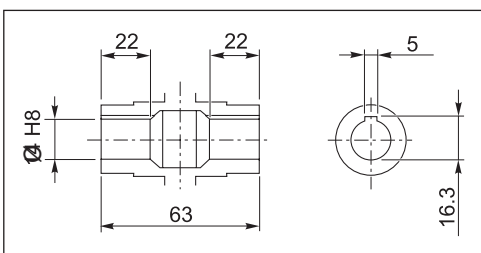

Albero lento cavo / Hollow output shaft

Dimensioni / Dimensions						Rapporti / Ratio					
AS	A	B	C	M	K	5...50			60...100		
						D	E	F	D	E	F
AS393	38.1	47.1	57	M5	55	11	4	12.8	9	3	10.4
AS391	73	69.6	86	M5	55	11	4	12.8	9	3	10.4
...

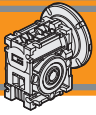

CM

Riduttori a vite senza fine
Wormgearboxes

MINI
TECNO

Dimensioni CM con flange motore AS

CM dimensions with motor flanges AS

CM040 - U - AS...

Lo spessore della flangia è variabile in funzione delle diverse lunghezze dell'albero motore.

Flange's thickness may vary depending on motorshaft's length.

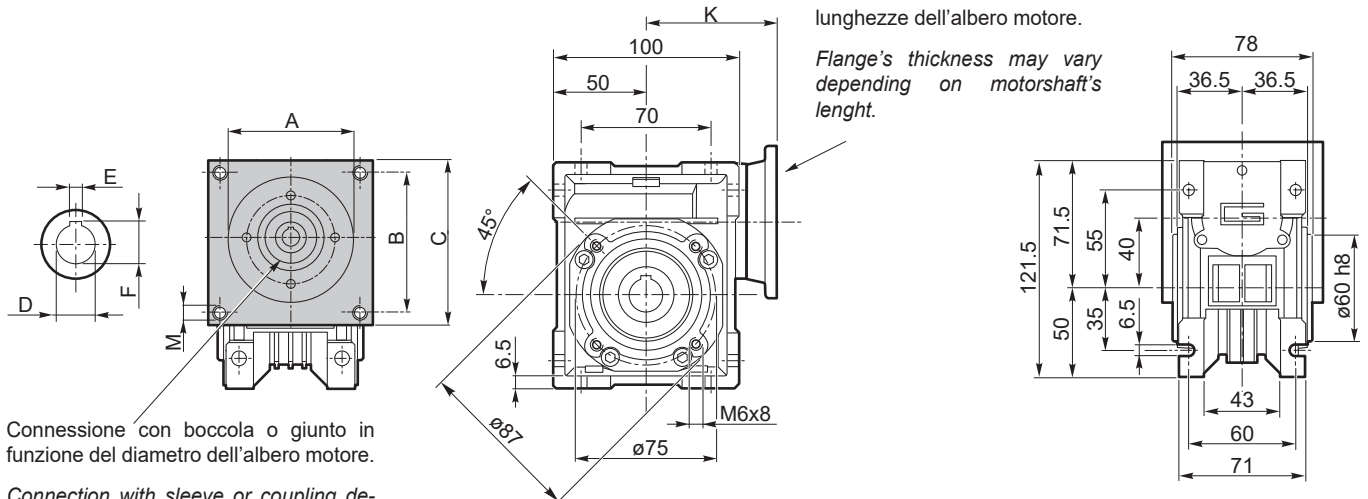

Connessione con boccola o giunto in funzione del diametro dell'albero motore.

Connection with sleeve or coupling depending on motorshaft's diameter.

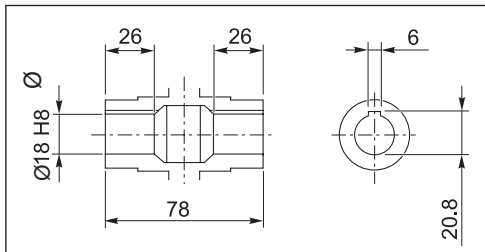
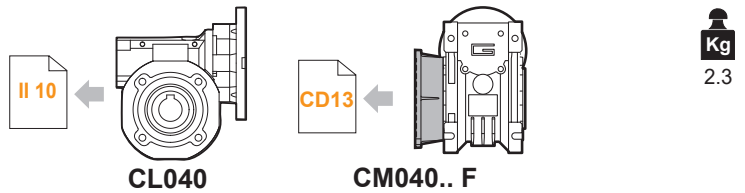

Albero lento cavo / Hollow output shaft

Dimensioni / Dimensions											
AS	A	B	C	M	K	Rapporti / Ratio					
						5...40			50...100		
						D	E	F	D	E	F
AS392FX	38.1	47.1	64	M5	73	14	5	16.3	11	4	12.8
AS384FX	73	69.6	86	M5	73	14	5	16.3	11	4	12.8
...

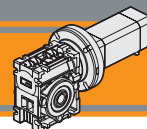

Dimensioni flange uscita

Output flange dimensions

CM.../... F... Flange uscita / Output flanges

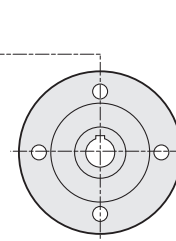
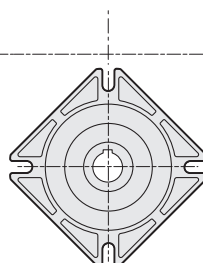
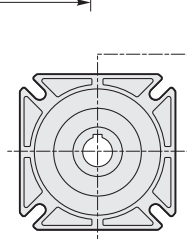
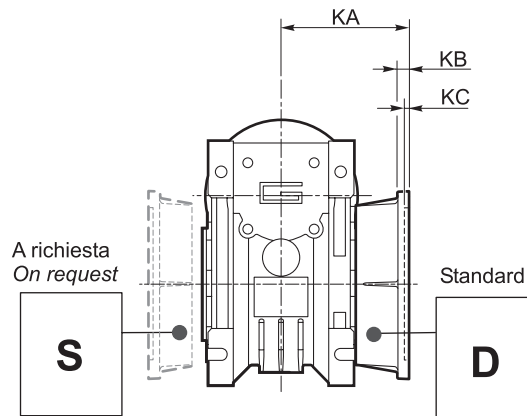
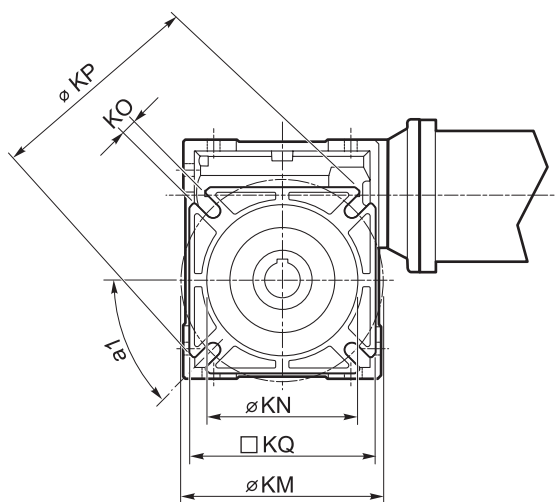

..CM026 ../.. F
..CM026 ../.. F28
..CM026 ../.. F30
..CM026 ../.. F30S
..CM030 ../.. F..
..CM040 ../.. F..

..CM026 ../.. F30C
..CM026 ../.. F30SC

..CM026 ../.. F100

	CM..F						CM..F28						CM..F30						CM..F30S ⁽¹⁾														
	a1	KA	KB	KC	KM	KN _{H8}	KO	KP	KQ	KA	KB	KC	KM	KN _{H8}	KO	KP	KQ	KA	KB	KC	KM	KN _{H8}	KO	KP	KQ	KA	KB	KC	KM	KN _{H8}	KO	KP	KQ
026 (D11)	45°	45	6	4.5	55-69	40	6.5	75	70	44	6.5	5	56-64	40	6.5	70	60	48	6.5	5	68	50	6.5	80	70	50	8.5	7	68	50	6.5	80	70
026 (D14)							6.5 (n.4)																										

(1): F30S eseguita con F30 e distanziale di spessore 2 mm / F30S made with F30 and spacer with 2mm thickness

	CM..F30C						CM..F30SC ⁽²⁾						CM..F100												
	a1	KA	KB	KC	KM	KN _{H8}	KO	KP	KQ	KA	KB	KC	KM	KN _{H8}	KO	KP	KQ	KA	KB	KC *	KM	KN _{H7}	KO	KP	KQ
026 (D11)	-	48	6.5	7	68	50	6.5	80	70	50	8.5	7	68	50	6.5	80	70	51.5	8	2 *	86	45	6.5	100	-
026 (D14)																									

(2): F30SC eseguita con F30C e distanziale di spessore 2 mm / F30SC made with F30C and spacer with 2mm thickness

*: Centraggio maschio / Male centering diameter

CM	CM..F						CM..FB						CM..FL												
	a1	KA	KB	KC	KM	KN _{H8}	KO	KP	KQ	KA	KB	KC	KM	KN _{H8}	KO	KP	KQ	KA	KB	KC	KM	KN _{H8}	KO	KP	KQ
030	45°	54.5	6	4	68	50	6.5(n.4)	80	70	—	—	—	—	—	—	—	—	—	—	—	—	—	—	—	—
040	45°	67	7.5	4	80-95	60	9(n.4)	110	95	80	8.5	5	115-125	95	9.5(n.4)	140	112	97	7.5	4.5	80-95	60	9 (n.4)	110	95

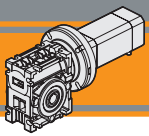

Opzioni

Options

VS - Vite sporgente / *Extended input shaft*

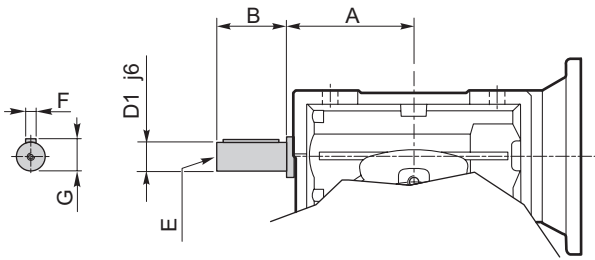

	A	B	D ₁ j6	E	F	G
CM 030	45	20	9	M4	3	10.2
CM 040	53	23	11	M5	4	12.5

Costruito su richiesta
Built on request

Accessori

Accessories

SC - Safety cover

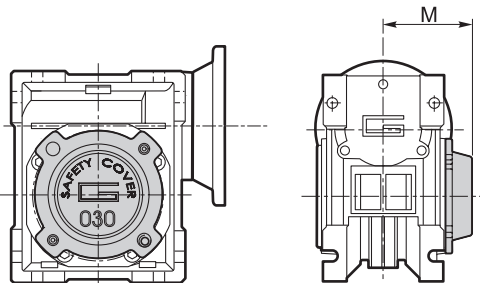

	M
CM 030	47
CM 040	54.5

WD - Kit washdown cover

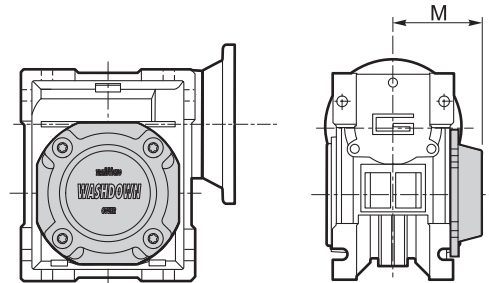

	M
CM 030	48
CM 040	55.5

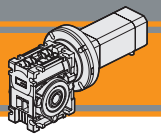

Accessori

Accessories

Albero lento

Output shaft

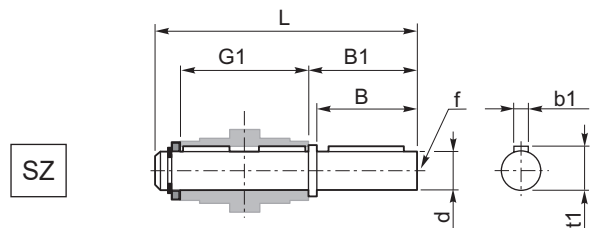
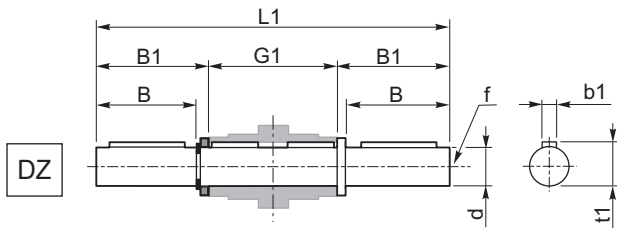

	d h7	B	B1	G1	L	L1	f	b1	t1
CM 030	14	30	32.5	63	102	128	M6	5	16
CM 040	18	40	43	78	128	164	M6	6	20.5

CM 026 (*)

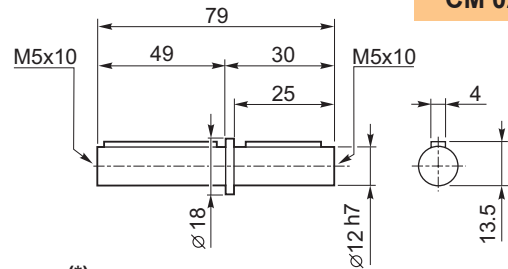

(*)
Nota: disponibile solo per cavo uscita Ø12
Note: available for output hollow shaft Ø12 only

Braccio di reazione

Torque arm

	K1	G	KG	KH	R
CM 030	85	14	23	8	15
CM 040	100	14	31	10	18

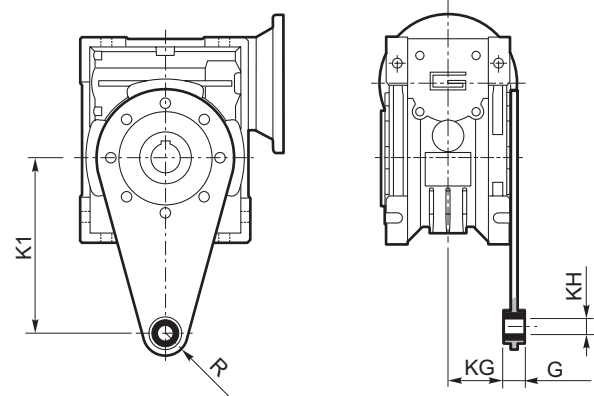

MINI  **TECNO**™
small but strong

BLP

Motoriduttori brushless CC epicicloidali
Brushless DC planetary gearmotors



MINI  **TECNO**™ brand of
TRANSTECNO®



BLDC

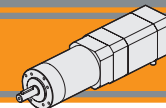

Indice	Index	Pag. Page
Caratteristiche tecniche	<i>Technical features</i>	CE2
Designazione	<i>Classification</i>	CE2
Simbologia	<i>Symbols</i>	CE2
Lubrificazione e temperatura	<i>Lubrication and temperature</i>	CE3
Carichi radiali	<i>Radial loads</i>	CE3
Rapporti	<i>Ratios</i>	CE3
PM52 con motore brushless BLS 022.240	<i>PM52 with brushless motor BLS 022.240</i>	CE4
PM52 con motore brushless BLS 043.240	<i>PM52 with brushless motor BLS 043.240</i>	CE6
PM62 con motore brushless BL 070.240	<i>PM62 with brushless motor BL 070.240</i>	CE8
PM62 con motore brushless BL 070.24B	<i>PM62 with brushless motor BL 070.24B</i>	CE8
PM62 con motore brushless BL 070.480	<i>PM62 with brushless motor BL 070.480</i>	CE8
PM62 con motore brushless BL 070.48B	<i>PM62 with brushless motor BL 070.48B</i>	CE8
PM62 con motore brushless BL 140.480	<i>PM62 with brushless motor BL 140.480</i>	CE8
Dati tecnici	<i>Technical data</i>	CE10
Dimensioni PM con flange motore AS	<i>PM dimensions with motor flanges AS</i>	CE11
Flange uscita	<i>Output flange</i>	CE12

Questa sezione annulla e sostituisce ogni precedente edizione o revisione. Qualora questa sezione non Vi sia giunta in distribuzione controllata, l'aggiornamento dei dati ivi contenuto non è assicurato. **In tal caso la versione più aggiornata è disponibile sul nostro sito internet www.transtecno.com**

This section replaces any previous edition and revision. If you obtained this catalogue other than through controlled distribution channels, the most up to date content is not guaranteed. In this case the latest version is available on our web site www.transtecno.com

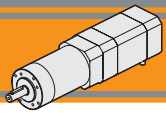

Caratteristiche tecniche

Technical features

Le caratteristiche principali dei motoriduttori brushless CC epicicloidali della serie BLP sono:

The main features of brushless DC planetary gearmotors BLP range are:

- Alimentazione in bassa tensione 24/36/48 Vcc
- Motore Brushless CC con grado di protezione IP55
- Coppie motori disponibili da 0.22 Nm a 1.4 Nm
- Lubrificazione permanente a grasso
- Completamente in metallo
- Doppio cuscinetto su albero di uscita
- Disponibili anche nella versione con solo riduttore, sia con flangia di entrata standard che con flangia e manicotto dedicati

- Low voltage power supply 24/36/48 Vdc
- Brushless DC motor in IP55 protection Standard
- Motor torque ratings available from 0.22 Nm up to 1.4 Nm
- Permanent grease long life lubrication
- Completely made out of metal
- Double ball bearing on output shaft
- Gearbox only version also available, with either standard input flange or customized flange and coupling

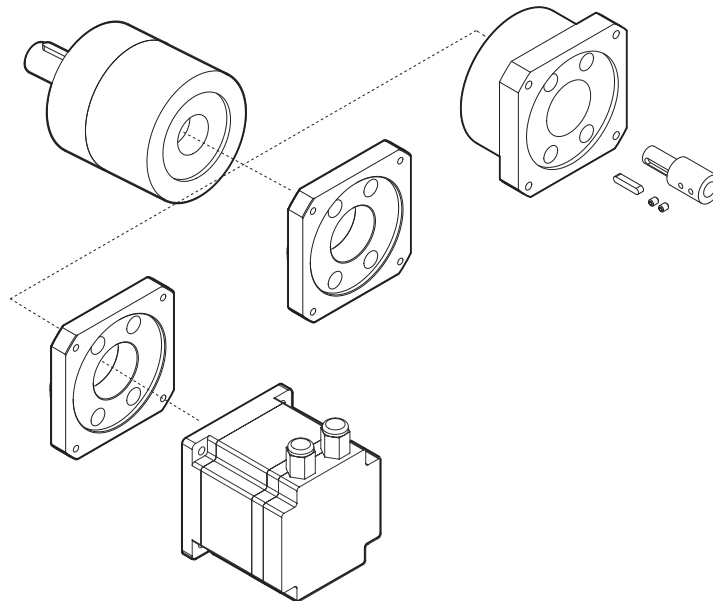

Designazione

Classification

RIDUTTORE / GEARBOX			
PM	52	2	46
Tipo Type	Grandezza Size	Stadi riduttore Gearbox stages	Rapporto in Ratio in
PM	52 62	1 2 3	Vedere tabelle See tables

MOTORE / MOTOR		
BL070.480	48V	BR
Tipo Type	Tensione Voltage	Freno Brake
BLS022.240	24V-36V	24V
BLS043.240	24V-36V	48V
BL070.240	24V	
BL070.24B	24V	
BL070.48B	48V	
BL070.480	48V	
BL140.480	48V	

Simbologia

Symbols

Ns	n° stadi / No. stages	Mn ₂	[Nm]	Coppia nominale in uscita in funzione di Pn1 Nominal output torque referred to Pn1
ir	rapporto reale / real ratio	V	[V]	Tensione / Voltage
M ₂	[Nm] coppia in uscita output torque	n _{1MAX}	[Rpm]	Velocità max entrata / Max input speed
Rd	rendimento dinamico / efficiency	n ₂	[Rpm]	Velocità in uscita / Output Speed
A ₂	[N] Carico assiale ammissibile in uscita Permitted output axial load	IP		Grado di protezione / Enclosure protection
R ₂	[N] Carico radiale ammissibile in uscita Permitted output radial load	Kg		Peso / Weight
Pn ₁	[kW] Potenza nominale in entrata Nominal input power	sf		Fattore di servizio / Service Factor

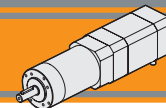

Lubrificazione e temperatura

Lubrication and temperature

I motoriduttori epicicloidali BLP sono lubrificati in modo permanente, non richiedono quindi ulteriore manutenzione. Questo gli consente di essere installati praticamente ovunque. Temperatura ambiente 0 ÷ 40 °C (in assenza di congelamento ed in assenza di condensa). Per temperature diverse, contattare nostro UT.

Planetary BLP gearmotors are life-time lubricated with grease, therefore they are maintenance free. They can be installed in any location. Ambient temperature 0 ÷ 40 °C (in the absence of freezing and condensation). For temperature outside this range please contact our technical dept.

Carichi radiali

Radial loads

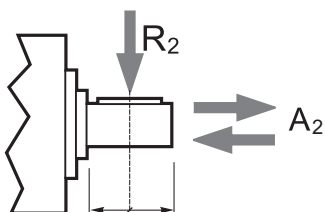

Ns	Carichi Radiali R ₂ [N] / Radial Load R ₂ [N]	
	PM52	PM62
1	200	240
2	320	360
3	450	520

Ns	Carichi Assiali A ₂ [N] / Axial Load A ₂ [N]	
	PM52	PM62
1	60	70
2	100	100
3	150	150

Rapporti

Ratios

Ns	PM 52 / 62		Rd	PM 52	PM 62
	in	ir		kg	kg
1	4	3.7	0.8	0.7	0.8
	4	4.28			
	5	5.18			
	7	6.75			
2	14	13.73	0.75	0.9	1.2
	16	15.88			
	18	18.36			
	19	19.2			
	22	22.2			
	25	25.01			
	27	26.85			
	29	28.93			
	35	34.97			
	46	45.56			
3	51	50.89	0.7	1.1	1.6
	59	58.85			
	68	68.06			
	71	71.16			
	79	78.71			
	93	92.7			
	95	95.17			
	100	99.5			
	107	107.2			
	115	115.07			
	124	123.97			
	130	129.62			
	139	139.13			
	150	149.9			
	169	168.84			
	181	181.24			
195	195.26				
236	236.09				
308	307.54				
4	a richiesta	on request			

Rapporti preferenziali
Preferred ratios

Disponibile a 4 stadi con rapporti fino a 2076
Available 4 stages with ratio up to 2076

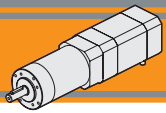

PM52 con motore brushless

PM52 with brushless motor

PM52			BLS022.240													
			24V						36V							
Ns	ir	in	n _{2MIN} [rpm]			n _{2MAX} [rpm]			n _{1MAX} [rpm]	n _{2MIN} [rpm]			n _{2MAX} [rpm]			n _{1MAX} [rpm]
			M ₂ [Nm]	sf		M ₂ [Nm]	sf			M ₂ [Nm]	sf		M ₂ [Nm]	sf		
1	3.7	4	81	0.7	9.0	811	0.7	6.1	3000	108	0.7	9.0	1081	0.7	5.4	4000
	4.28	4	70	0.8	7.8	701	0.8	5.3		93	0.8	7.8	935	0.8	4.7	
	5.18	5	58	0.9	6.4	579	0.9	4.4		77	0.9	6.4	772	0.9	3.9	
	6.75	7	44	1.2	4.9	444	1.2	3.3		59	1.2	4.9	593	1.2	3.0	
13.73	14	22	2.3	7.6	218	2.3	5.2	29		2.3	7.6	291	2.3	4.6		
15.88	16	19	2.6	6.6	189	2.6	4.5	25		2.6	6.6	252	2.6	4.0		
18.36	18	16	3.0	5.7	163	3.0	3.9	22		3.0	5.7	218	3.0	3.4		
19.2	19	16	3.2	5.4	156	3.2	3.7	21		3.2	5.4	208	3.2	3.3		
22.2	22	14	3.7	4.7	135	3.7	3.2	18		3.7	4.7	180	3.7	2.8		
25.01	25	12	4.1	4.2	120	4.1	2.8	16		4.1	4.2	160	4.1	2.5		
26.9	27	11	4.4	3.9	112	4.4	2.6	15		4.4	3.9	149	4.4	2.3		
28.9	29	10	4.8	3.6	104	4.8	2.5	14		4.8	3.6	138	4.8	2.2		
35.0	35	8.6	5.8	3.0	86	5.8	2.0	11		5.8	3.0	114	5.8	1.8		
45.6	46	6.6	7.5	2.3	66	7.5	1.6	8.8		7.5	2.3	88	7.5	1.4		
50.9	51	5.9	8	4.7	59	7.8	3.2	7.9		8	4.7	79	7.8	2.8		
58.9	59	5.1	9	4.1	51	9.1	2.8	6.8		9	4.1	68	9.1	2.4		
68.1	68	4.4	10	3.5	44	10	2.4	5.9	10	3.5	59	10	2.1			
71.2	71	4.2	11	3.4	42	11	2.3	5.6	11	3.4	56	11	2.0			
78.7	79	3.8	12	3.0	38	12	2.1	5.1	12	3.0	51	12	1.8			
92.7	93	3.2	14	2.6	32	14	1.7	4.3	14	2.6	43	14	1.5			
95.2	95	3.2	15	2.5	32	15	1.7	4.2	15	2.5	42	15	1.5			
99.5	100	3.0	15	2.4	30	15	1.6	4.0	15	2.4	40	15	1.4			
107.2	107	2.8	17	2.2	28	17	1.5	3.7	17	2.2	37	17	1.3			
115.07	115	2.6	18	2.1	26	18	1.4	3.5	18	2.1	35	18	1.2			
123.97	124	2.4	19	1.9	24	19	1.3	3.2	19	1.9	32	19	1.2			
129.62	130	2.3	20	1.8	23	20	1.3	3.1	20	1.8	31	20	1.1			
139.13	139	2.2	21	1.7	22	21	1.2	2.9	21	1.7	29	21	1.0			
149.9	150	2.0	23	1.6	20	23	1.1	2.7	23	1.6	27	23	1.0			
168.84	169	1.8	26	1.4	18	26	1.0	2.4	26	1.4	24	26	0.8			
181.24	181	1.7	28	1.3	17	28	0.9	2.2	28	1.3	22	28	0.8			
195.26	195	1.5	30	1.2	15	30	0.8	2.0	30	1.2	20	30	0.7			
236.09	236	1.3	36	1.0	13	36	0.7	1.7	36	1.0	17	31	0.7			
307.54	308	1.0	47	0.8	9.8	36	0.7	1.3	47	0.8	13	31	0.7			

NOTA: per servizio continuo o altamente intermittente, contattare il servizio tecnico

NOTE: for continuous or highly intermittent duty, please contact our technical service

Rapporti preferenziali
Preferred ratios

Attenzione: superamento della coppia nominale supportata dal riduttore per servizio S1. Contattare il ns. servizio tecnico
Attention: rated torque withstood by gear reducer for service in S1 is exceeded. Please, contact our technical office.

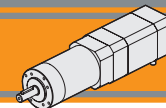

PM52 con motore brushless

PM52 with brushless motor

Tipo Type	Numero di poli Number of poles	Numero di fasi Number of phase	Tensione Rated voltage [V]	Numero di giri Rated speed [rpm]	Coppia nominale Rated torque [Nm]	Potenza nominale Rated power [W]
BLS022.240	4	3	36	4000	0.22	92
			24	3000		70
Tipo Type	Coppia massima Peak torque [Nm]	Corrente nominale Rated current [A]	Resistenza Resistance [ohm]	Induttanza Inductance [mH]	Corrente massima Peak current [A]	Peso Weight [kg]
BLS022.240	0.44	3.7	0.64	3.1	7.4	0.72



PM52..
+
BLS022.240

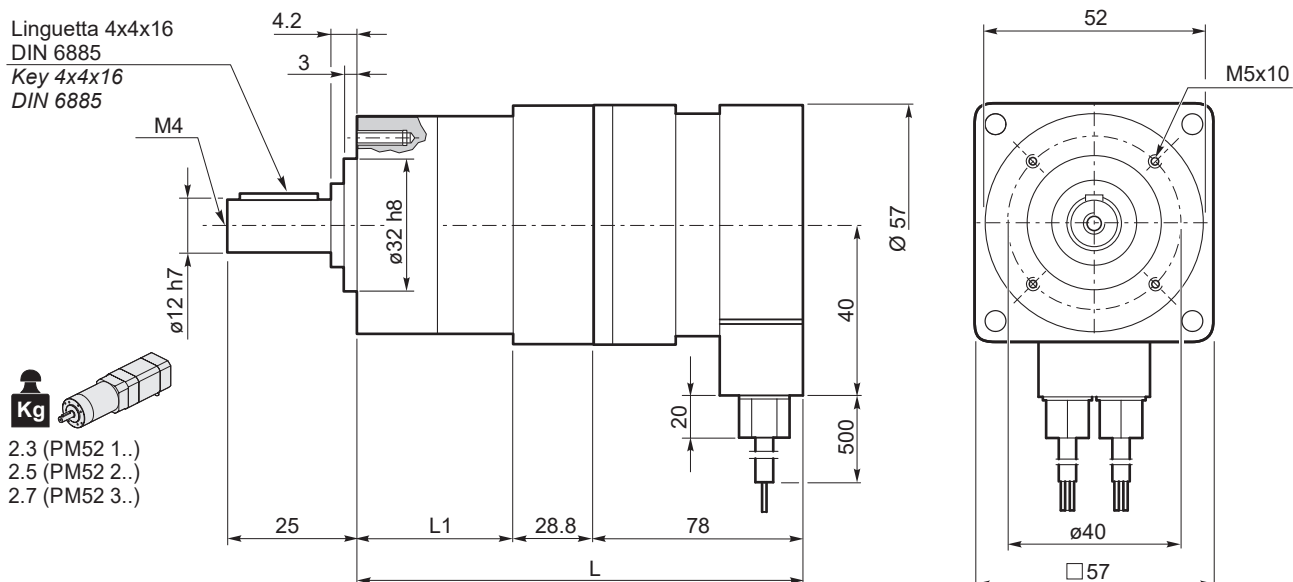

- Kg**
- 2.3 (PM52 1..)
 - 2.5 (PM52 2..)
 - 2.7 (PM52 3..)

PM52	BLS022.240	
	Ns	L
	1	47.2
	2	61.3
	3	75.6
		L
		155.5
		169.5
		183.5



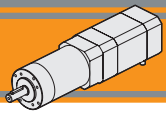

PM52 con motore brushless

PM52 with brushless motor

PM52			BLS043.240													
			24V						36V							
Ns	ir	in	n _{2MIN} [rpm]			n _{2MAX} [rpm]			n _{1MAX} [rpm]	n _{2MIN} [rpm]			n _{2MAX} [rpm]			n _{1MAX} [rpm]
			M ₂ [Nm]	sf		M ₂ [Nm]	sf			M ₂ [Nm]	sf		M ₂ [Nm]	sf		
1	3.7	4	81	1.3	4.6	811	1.3	3.1	3000	108	1.3	4.6	1081	1.3	2.8	4000
	4.28	4	70	1.5	4.0	701	1.5	2.7		93	1.5	4.0	935	1.5	2.4	
	5.18	5	58	1.8	3.3	579	1.8	2.2		77	1.8	3.3	772	1.8	2.0	
	6.75	7	44	2.3	2.5	444	2.3	1.7		59	2.3	2.5	593	2.3	1.5	
13.73	14	22	4.4	3.9	218	4.4	2.6	29		4.4	3.9	291	4.4	2.3		
15.88	16	19	5.1	3.4	189	5.1	2.3	25		5.1	3.4	252	5.1	2.0		
18.36	18	16	5.9	2.9	163	5.9	2.0	22		5.9	2.9	218	5.9	1.7		
19.2	19	16	6.2	2.8	156	6.2	1.9	21		6.2	2.8	208	6.2	1.7		
22.2	22	14	7.2	2.4	135	7.2	1.6	18		7.2	2.4	180	7.2	1.4		
25.01	25	12	8.1	2.1	120	8.1	1.5	16		8.1	2.1	160	8.1	1.3		
26.9	27	11	8.7	2.0	112	8.7	1.4	15		8.7	2.0	149	8.7	1.2		
28.9	29	10	9.3	1.8	104	9.3	1.3	14		9.3	1.8	138	9.3	1.1		
35.0	35	8.6	11	1.5	86	11.3	1.0	11		11	1.5	114	11	0.9		
45.6	46	6.6	15	1.2	66	14.7	0.8	8.8		15	1.2	88	15	0.7		
50.9	51	5.9	15	2.4	59	15.3	1.6	7.9		15	2.4	79	15	1.4		
58.9	59	5.1	18	2.1	51	17.7	1.4	6.8		18	2.1	68	18	1.2		
68.1	68	4.4	20	1.8	44	20	1.2	5.9	20	1.8	59	20	1.1			
71.2	71	4.2	21	1.7	42	21	1.2	5.6	21	1.7	56	21	1.0			
78.7	79	3.8	24	1.6	38	24	1.1	5.1	24	1.6	51	24	0.9			
92.7	93	3.2	28	1.3	32	28	0.9	4.3	28	1.3	43	28	0.8			
95.2	95	3.2	29	1.3	32	29	0.9	4.2	29	1.3	42	29	0.8			
99.5	100	3.0	30	1.2	30	30	0.8	4.0	30	1.2	40	30	0.7			
107.2	107	2.8	32	1.1	28	32	0.8	3.7	32	1.1	37	31	0.7			
115.07	115	2.6	35	1.1	26	35	0.7	3.5	35	1.1	35	31	0.7			
123.97	124	2.4	37	1.0	24	36	0.7	3.2	37	1.0	32	31	0.7			
129.62	130	2.3	39	0.9	23	36	0.7	3.1	39	0.9	31	31	0.7			
139.13	139	2.2	42	0.9	22	36	0.7	2.9	42	0.9	29	31	0.7			
149.9	150	2.0	45	0.8	20	36	0.7	2.7	45	0.8	27	31	0.7			
168.84	169	1.8	51	0.7	18	36	0.7	2.4	51	0.7	24	31	0.7			
181.24	181	1.7	53	0.7	17	36	0.7	2.2	53	0.7	22	31	0.7			
195.26	195	1.5	53	0.7	15	36	0.7	2.0	53	0.7	20	31	0.7			
236.09	236	1.3	53	0.7	13	36	0.7	1.7	53	0.7	17	31	0.7			
307.54	308	1.0	53	0.7	9.8	36	0.7	1.3	53	0.7	13	31	0.7			

NOTA: per servizio continuo o altamente intermittente, contattare il servizio tecnico

NOTE: for continuous or highly intermittent duty, please contact our technical service

Rapporti preferenziali
Preferred ratios

Attenzione: superamento della coppia nominale supportata dal riduttore per servizio S1. Contattare il ns. servizio tecnico
Attention: rated torque withstood by gear reducer for service in S1 is exceeded. Please, contact our technical office.

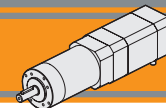

PM52 con motore brushless

PM52 with brushless motor

Tipo Type	Numero di poli Number of poles	Numero di fasi Number of phase	Tensione Rated voltage [V]	Numero di giri Rated speed [rpm]	Coppia nominale Rated torque [Nm]	Potenza nominale Rated power [W]
BLS043.240	4	3	36	4000	0.43	180
			24	3000		130
Tipo Type	Coppia massima Peak torque [Nm]	Corrente nominale Rated current [A]	Resistenza Resistance [ohm]	Induttanza Inductance [mH]	Corrente massima Peak current [A]	Peso Weight [kg]
BL043.240	0.86	6	0.35	1	12.0	1.25



PM52..
+
BLS043.240

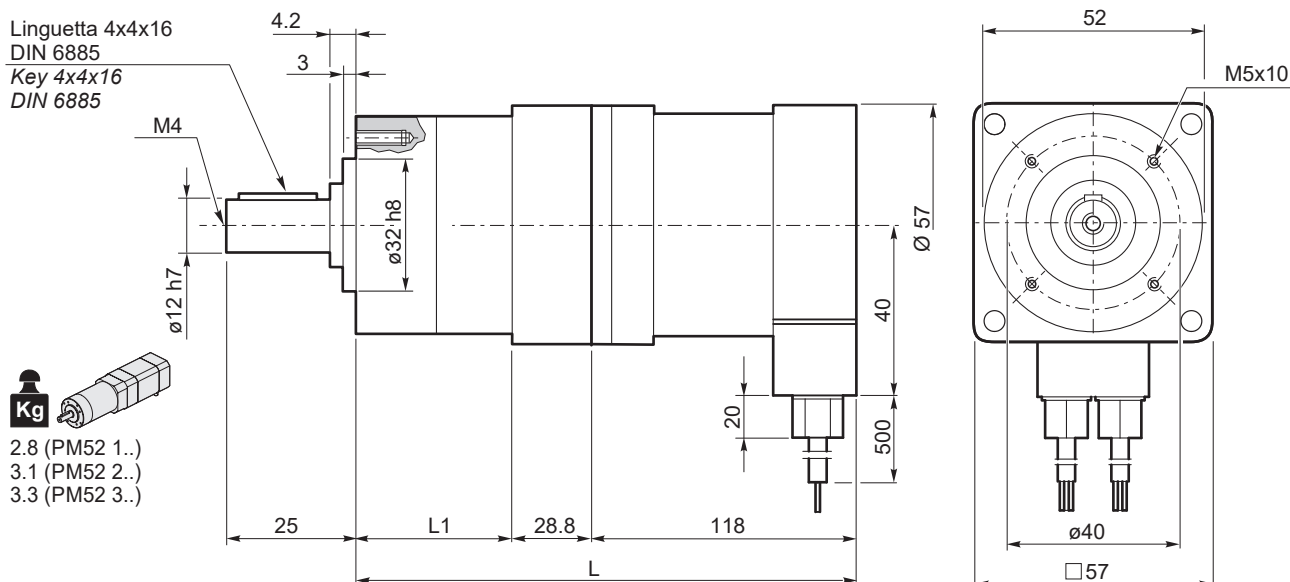

PM52	BLS043.240	
	Ns	L
	1	47.2
	2	61.3
	3	75.6



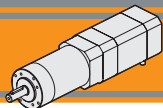

PM62 con motore brushless

PM62 with brushless motor

PM62			BL070.240 / BL070.24B BL070.480 / BL070.48B						BL140.480										
			24V / 48V						48V										
Ns	ir	in	n _{2MIN} [rpm]			n _{2MAX} [rpm]			n _{1MAX} [rpm]	n _{2MIN} [rpm]			n _{2MAX} [rpm]			n _{1MAX} [rpm]			
			M ₂ [Nm]	sf		M ₂ [Nm]	sf			M ₂ [Nm]	sf		M ₂ [Nm]	sf					
1	3.7	4	81	2.1	5.6	811	2.1	3.8	3000	81	4.1	2.8	811	4.1	1.9	3000			
	4.28	4	70	2.4	4.8	701	2.4	3.3		70	4.8	2.4	701	4.8	1.6				
	5.18	5	58	2.9	4.0	579	2.9	2.7		58	5.8	2.0	579	5.8	1.3				
	6.75	7	44	3.8	3.0	444	3.8	2.1		44	7.6	1.5	444	7.6	1.0				
2	13.73	14	22	7.2	5.1	218	7.2	3.5	3000	22	14.4	2.6	218	14.4	1.7	3000			
	15.88	16	19	8.3	4.4	189	8.3	3.0		19	16.7	2.2	189	16.7	1.5				
	18.36	18	16	9.6	3.8	163	9.6	2.6		16	19.3	1.9	163	19.3	1.3				
	19.2	19	16	10	3.7	156	10	2.5		16	20	1.8	156	20	1.2				
	22.2	22	14	12	3.2	135	12	2.1		14	23	1.6	135	23	1.1				
	25.01	25	12	13	2.8	120	13	1.9		12	26	1.4	120	26	1.0				
	26.9	27	11	14	2.6	112	14	1.8		11	28	1.3	112	28	0.9				
	28.9	29	10	15	2.4	104	15	1.6		10	30	1.2	104	30	0.8				
	35.0	35	8.6	18	2.0	86	18	1.4		8.6	37	1.0	86	36	0.7				
	45.6	46	6.6	24	1.5	66	24	1.0		6.6	48	0.8	66	36	0.7				
	3	50.9	51	5.9	25	3.0	59	25		2.0	3000	5.9	50	1.5	59		50	1.0	3000
		58.9	59	5.1	29	2.6	51	29		1.7		5.1	58	1.3	51		58	0.9	
68.1		68	4.4	33	2.2	44	33	1.5	4.4	67		1.1	44	67	0.7				
71.2		71	4.2	35	2.1	42	35	1.4	4.2	70		1.1	42	70	0.7				
78.7		79	3.8	39	1.9	38	39	1.3	3.8	77		1.0	38	71	0.7				
92.7		93	3.2	45	1.6	32	45	1.1	3.2	91		0.8	32	71	0.7				
95.2		95	3.2	47	1.6	32	47	1.1	3.2	93		0.8	32	71	0.7				
99.5		100	3.0	49	1.5	30	49	1.0	3.0	98		0.8	30	71	0.7				
107.2		107	2.8	53	1.4	28	53	1.0	2.8	105		0.7	28	71	0.7				
115.07		115	2.6	56	1.3	26	56	0.9	2.6	105		0.7	26	71	0.7				
123.97		124	2.4	61	1.2	24	61	0.8	2.4	105		0.7	24	71	0.7				
129.62		130	2.3	64	1.2	23	64	0.8	2.3	105		0.7	23	71	0.7				
139.13		139	2.2	68	1.1	22	68	0.7	2.2	105		0.7	22	71	0.7				
149.9		150	2.0	73	1.0	20	71	0.7	2.0	105		0.7	20	71	0.7				
168.84	169	1.8	83	0.9	18	71	0.7	1.8	105	0.7	18	71	0.7						
181.24	181	1.7	89	0.8	17	71	0.7	1.7	105	0.7	17	71	0.7						
195.26	195	1.5	96	0.8	15	71	0.7	1.5	105	0.7	15	71	0.7						
236.09	236	1.3	105	0.7	13	71	0.7	1.3	105	0.7	13	71	0.7						
307.54	308	1.0	105	0.7	9.8	71	0.7	1.0	105	0.7	9.8	71	0.7						

NOTA: per servizio continuo o altamente intermittente, contattare il servizio tecnico

NOTE: for continuous or highly intermittent duty, please contact our technical service

Rapporti preferenziali
Preferred ratios

Attenzione: superamento della coppia nominale supportata dal riduttore per servizio S1.
Contattare il ns. servizio tecnico
Attention: rated torque withstood by gear reducer for service in S1 is exceeded.
Please, contact our technical office.

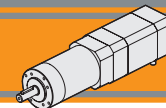

PM62 con motore brushless

PM62 with brushless motor

Tipo Type	Numero di poli Number of poles	Numero di fasi Number of phase	Tensione Rated voltage [V]	Numero di giri Rated speed [rpm]	Coppia nominale Rated torque [Nm]	Potenza nominale Rated power [W]
BL070.240 BL070.24B	8	3	24	3000	0.7	220
BL070.480 BL070.48B	8	3	48	3000	0.7	220
BL140.480	8	3	48	3000	1.4	440
Tipo Type	Coppia massima Peak torque [Nm]	Corrente nominale Rated current [A]	Resistenza Resistance [ohm]	Induttanza Inductance [mH]	Corrente massima Peak current [A]	Peso Weight [kg]
BL070.240 BL070.24B	2.1	13	0.091	0.23	26	2.1
BL070.480 BL070.48B	1.4	6.5	0.34	1.0	13	2.1
BL140.480	2.8	13	0.16	0.5	26	3.15

Azionamenti
Drives → **CF5**

PM62..

+
BL070.240
BL070.480
BL070.48B
BL140.480

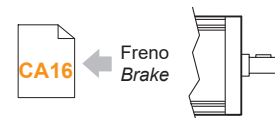
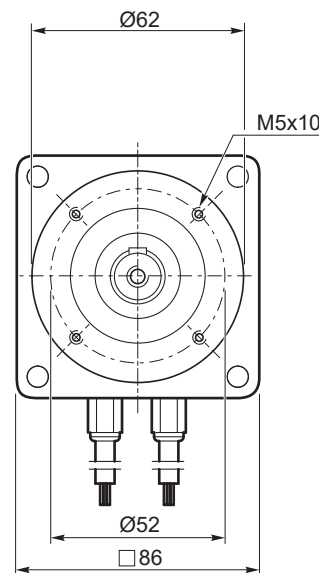
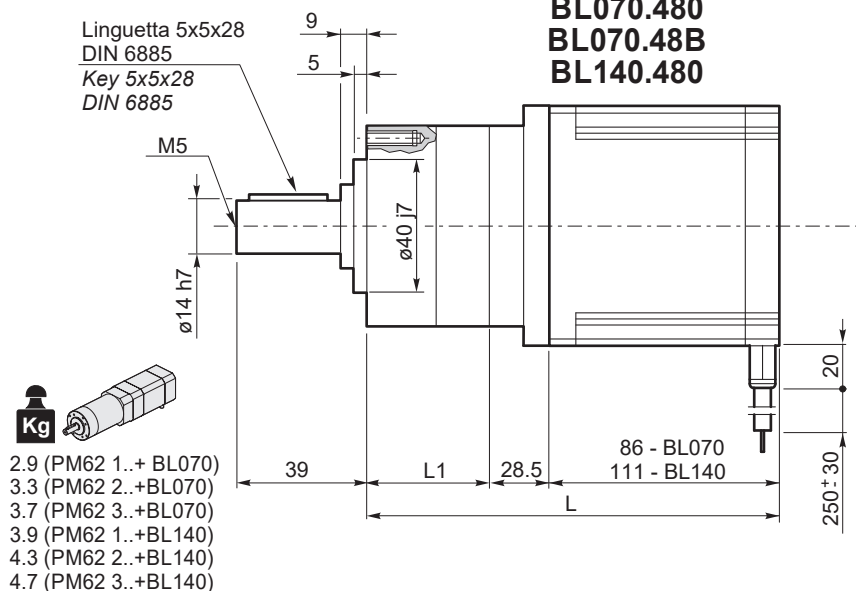

BL070.24B
BL070.48B

PM62	Ns	L1	BL 070.480	BL 140.480
			L	L
	1	45.3	163.5	188.5
	2	62.2	179.5	204.5
	3	79.2	195.5	220.5



PM62.. AS...

PM62.. C...

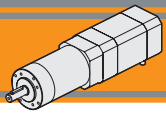

BLP

Motoriduttori brushless CC epicicloidali
Brushless DC planetary gearmotors

MINI
TECNO

Dati tecnici

$n_1 = 3000$ rpm

Technical data

Ns	ir	in	PM52			PM62		
			R _d	M _{n2} [Nm]	R ₂ [N]	R _d	M _{n2} [Nm]	R ₂ [N]
1	3.70	4	0.80	4	200	0.80	8	240
	4.28	4						
	5.18	5						
	6.75	7						
2	13.73	14	0.75	12	320	0.75	25	360
	15.88	16						
	18.36	18						
	19.20	19						
	22.20	22						
	25.01	25						
	26.85	27						
	28.93	29						
	34.97	35						
	45.56	46						
3	50.89	51	0.70	25	450	0.70	50	520
	58.85	59						
	68.06	68						
	71.16	71						
	78.71	79						
	92.70	93						
	95.17	95						
	99.50	100						
	107.20	107						
	115.07	115						
	123.97	124						
	129.62	130						
	139.13	139						
	149.90	150						
	168.84	169						
181.24	181							
195.26	195							
236.09	236							
307.54	308							

Rapporti preferenziali per le taglie P52 e P62.
Preferred ratios for sizes P52 e P62.

Disponibili 4 stadi con rapporti fino a 2076 / Available 4 stages with ratio up to 2076

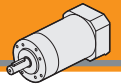
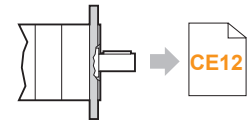
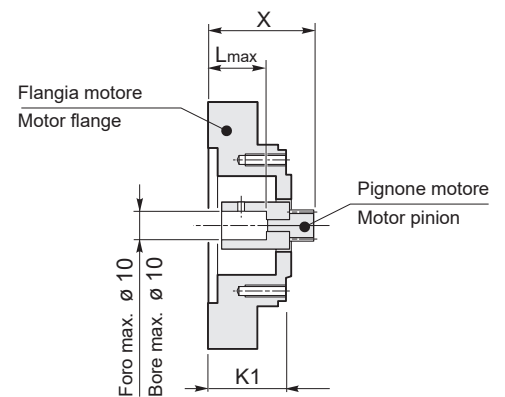
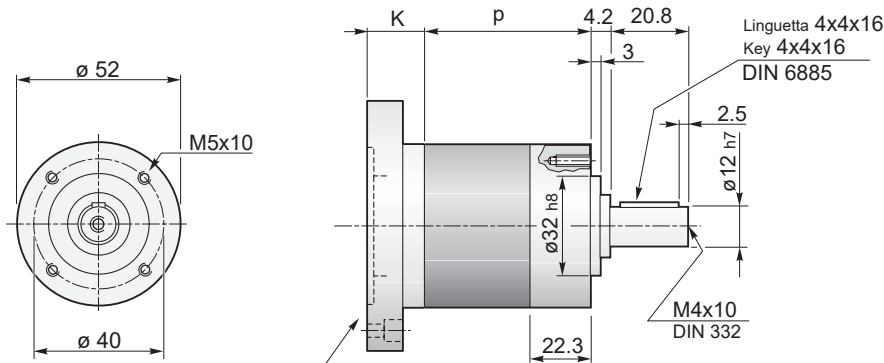
Dimensioni PM con flange motore AS
PM dimensions with motor flanges AS
PM52 - U - AS...

PM52.. C...

Lo spessore della flangia è variabile in funzione delle diverse lunghezze dell'albero motore.

Flange's thickness may vary depending on motorshaft's length.

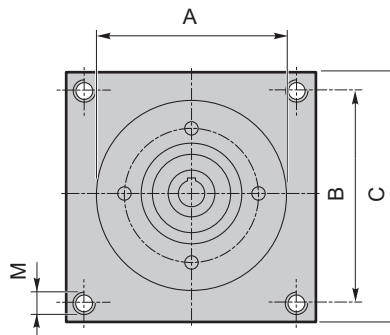
Dimensioni / Dimensions							
AS	A	B	C	M	K1	L _{max}	X
AS394PM	38.1	47.1	57	M5	31.2	23	41.5
...

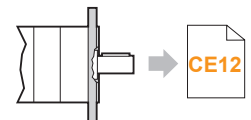
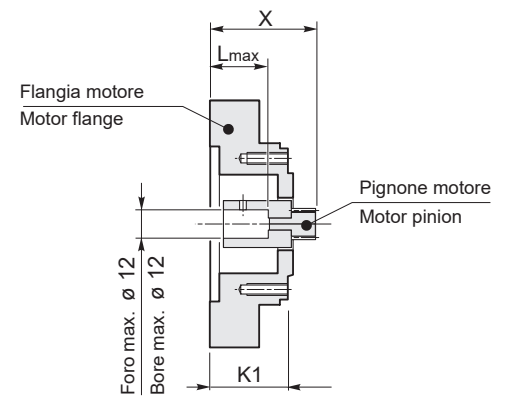
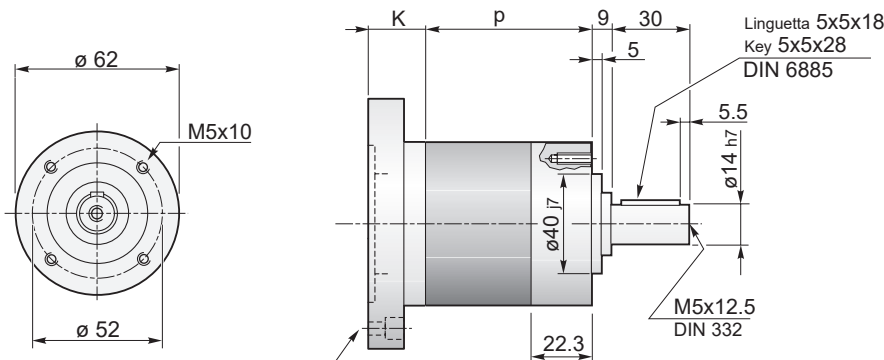

	Lunghezza riduttore Gearbox length		Kg
	P		
PM52...	1	47.2	0.7
	2	61.3	0.9
	3	75.6	1.1

PM62 - U - AS...

PM62.. C...

Lo spessore della flangia è variabile in funzione delle diverse lunghezze dell'albero motore.

Flange's thickness may vary depending on motorshaft's length.

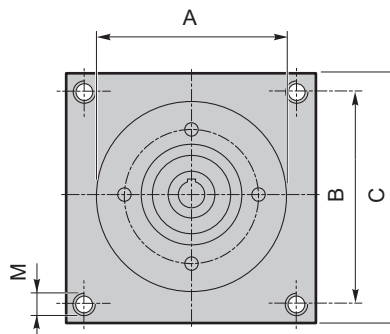
Dimensioni / Dimensions							
AS	A	B	C	M	K1	L _{max}	X
AS389PM	73	69.6	86	M5	30.8	23	44.3
...

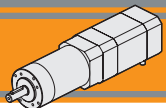
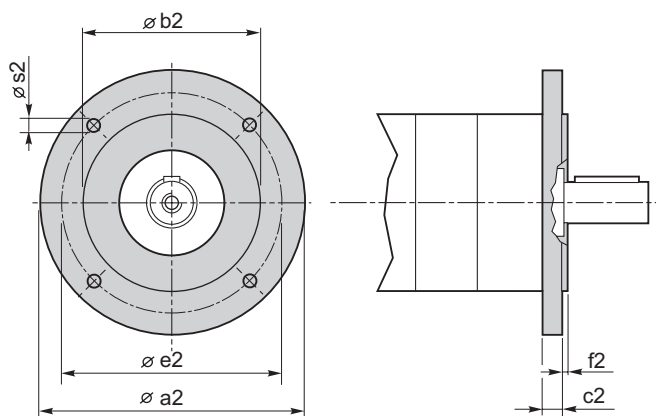

	Lunghezza riduttore Gearbox length		Kg
	P		
PM62...	1	45.3	0.8
	2	62.2	1.2
	3	79.2	1.6

**Dimensioni flange uscita****Output flange dimensions****PM.. C..**

Flange uscita / Output flanges							
PM	a2	b2	c2	e2	f2	s2	Flangia Flange
52	80	50 j7	9	65	2.5	M5	C80
	90	60 j7	9	75	2.5	5.5	C90
	105	70 j7	9	85	2.5	6.5	C105
	120	80 j7	9	100	3.0	6.5	C120
62	80	50 j7	9	65	2.5	M5	C80
	90	60 j7	9	75	2.5	5.5	C90
	105	70 j7	9	85	2.5	6.5	C105
	120	80 j7	9	100	3.0	6.5	C120

Azionamenti per motori brushless CC
Brushless DC motor controls





	Indice	Index	Pag. Page
	Selezione azionamento Selezione azionamento per motori Brushless	Drive selection <i>Brushless motor drive selection guide</i>	CF1
BLD07-IT	AZIONAMENTO 4Q PER MOTORI BRUSHLESS CC	4Q DRIVE FOR DC BRUSHLESS MOTORS	
	Caratteristiche tecniche	<i>Technical features</i>	CF2
	Dimensioni	<i>Dimensions</i>	CF2
	Collegamenti	<i>Connections</i>	CF3
BLD15	AZIONAMENTO 4Q PER MOTORI BRUSHLESS CC	4Q DRIVE FOR DC BRUSHLESS MOTORS	
	Caratteristiche standard	<i>Standard characteristic</i>	CF5
	Dati tecnici principali	<i>Specifications</i>	CF5
	Dimensioni	<i>Dimensions</i>	CF6
	Collegamenti	<i>Connection</i>	CF7
BLD60 DIGITAL	AZIONAMENTO 4Q PER MOTORI BRUSHLESS CC	4Q DRIVE FOR DC BRUSHLESS MOTORS	
	Caratteristiche standard	<i>Standard characteristic</i>	CF9
	Dati tecnici principali	<i>Specifications</i>	CF9
	Dimensioni	<i>Dimensions</i>	CF9
	Collegamenti per motore Brushless serie BL	<i>Connections for Brushless motor BL series</i>	CF10

SELEZIONE AZIONAMENTO

DRIVE SELECTION

Selezione azionamento per motore brushless

Brushless motor drive selection guide

Motori applicabili <i>Suitable motors</i>	Scheda / <i>Type</i>	Corrente Nominale / <i>Rated Current</i> (A)	Corrente di Picco / <i>Peak Current</i> (A)
BLS022.240	BLD07-IT / BLD15	7 / 15	14 / 30
BLS043.240	BLD07-IT / BLD15	7 / 15	14 / 30
BL070.240 / BL070.24B	BLD15	15	30
BL070.480 / BL070.48B	BLD15	15	30
BL140.480	BLD15 / BLD60 DIGITAL	15 / 50	30 / 75
BL210.480 / BL210.48E	BLD60 DIGITAL	50	75

Questa sezione annulla e sostituisce ogni precedente edizione o revisione. Qualora questa sezione non Vi sia giunta in distribuzione controllata, l'aggiornamento dei dati ivi contenuto non è assicurato. **In tal caso la versione più aggiornata è disponibile sul nostro sito internet www.transtecno.com**

This section replaces any previous edition and revision. If you obtained this catalogue other than through controlled distribution channels, the most up to date content is not guaranteed. In this case the latest version is available on our web site www.transtecno.com

**BLD07-IT****AZIONAMENTO 4Q
PER MOTORI BRUSHLESS CC****4Q DRIVE
FOR DC BRUSHLESS MOTORS**

L'azionamento BLD07-IT è un driver che nelle sue piccole dimensioni implementa una completa gestione in velocità del motore brushless con retroazione da sensori di Hall. Il driver è stato pensato per essere di facile utilizzo, affidabile ed economico.

The BLD07-IT drive is a driver that in its small size implements a complete speed management of the brushless motor with feedback from Hall sensors. The driver has been designed to be easy to use, reliable and economical.

Caratteristiche standard**Standard features**

- Azionamento bidirezionale rigenerativo
 - Alimentazione singola CC
 - 3 Leds per la diagnostica (stato ed allarmi)
 - Protetto per corto circuito, min/max tensione, mancanza celle di Hall
 - Protezione termica motore Ixt
 - Connettori estraibili (segnali e potenza)
 - Comando di velocità analogico 0 +10Vcc e PWM (2 kHz)
 - 4 Ingressi digitali – optoisolati
 - 2 Uscite NPN - allarmi e frequenza di lavoro
 - Regolazione rampa di accelerazione
- Bidirectional regenerative operation
 - Single supply DC voltage
 - 3 diagnostic Leds (State and Alarms)
 - Protections for: Over/Under voltage, Over current, Hall missing
 - Ixt motor current protection
 - Power and signals extractable connectors
 - Analog speed command 0 + 10Vdc and PWM (2 kHz)
 - 4 Digital inputs – optoisolated
 - 2 NPN - fault drive and running frequency
 - Acceleration adjustment

Dati tecnici principali**Specifications**

- Idoneo per motori BLDC trifase 4/8 poli
 - Retroazione digitale sensori di Hall
 - Controllo motore in frequenza PWM 20 kHz
 - Temperatura operativa 0/+40°C
 - Ingresso analogico 0/+10Vcc
 - Rampa accelerazione regolabile 0.1/1.0sec (tramite dip switch)
 - Regolazione corrente max
 - Regolazione della velocità (potenziometro esterno o interno) esterno 10KΩ
- Suitable for 3ph BLDC motors 4/8 poles
 - Digital feedback Hall sensors
 - Motor control in PWM frequency 20 kHz
 - Operative temperature 0/+40°C
 - Analog inputs range 0/+10Vdc
 - Acceleration ramp adjustable (by dip switch) 0.1/1.0sec
 - Current max regulation
 - Speed change regulation (by external or internal pot) external 10KΩ

MODELLO / MODEL		BLD07-IT
Tensione nominale motore <i>Motor DC Voltage</i>	(Vdc)	24 - 36
Tensione di alimentazione min / max <i>Supply DC Voltage Range min / max</i>	(Vdc)	20-40
Corrente nominale <i>Rated Current</i>	(A)	7
Corrente di picco (1) <i>Peak Current</i>	(A)	14
Potenza nominale (2) <i>Rated Power</i>	(W)	230
Potenza di picco (3) <i>Peak Power</i>	(W)	460

(1) La corrente di picco viene erogata per un tempo di circa 2 secondi
(1) Peak current (Adc) for 2 sec.

(2) La potenza nominale è riferita al valore di tensione e di corrente nominale
(2) Power of amplifier at the rated current and rated voltage

(3) La potenza di picco è riferita al valore di tensione nominale e di corrente di picco
(3) Power of amplifier at the peak current and rated voltage



BLD07-IT

**AZIONAMENTO 4Q
PER MOTORI BRUSHLESS CC**

**4Q DRIVE
FOR DC BRUSHLESS MOTORS**

Dimensioni

Dimensions

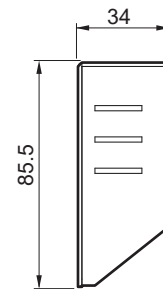
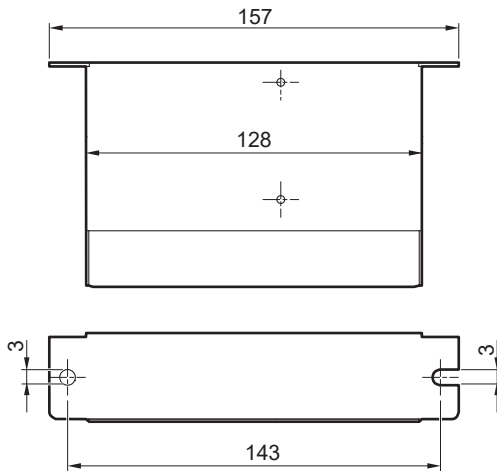

Collegamenti

Connections

L'azionamento BLD07-IT è dotato di:

- connettore estraibile a 5 poli per la parte di potenza
- tre connettori estraibili, per un totale di 16 morsetti, per la gestione dei segnali in ingresso ed in uscita.

The BLD07-IT drive is equipped with:

- Removable connector with 5 terminals for the power part;
- 3 removable connectors, for a total of 16 terminals, for the management of the input and output signal.

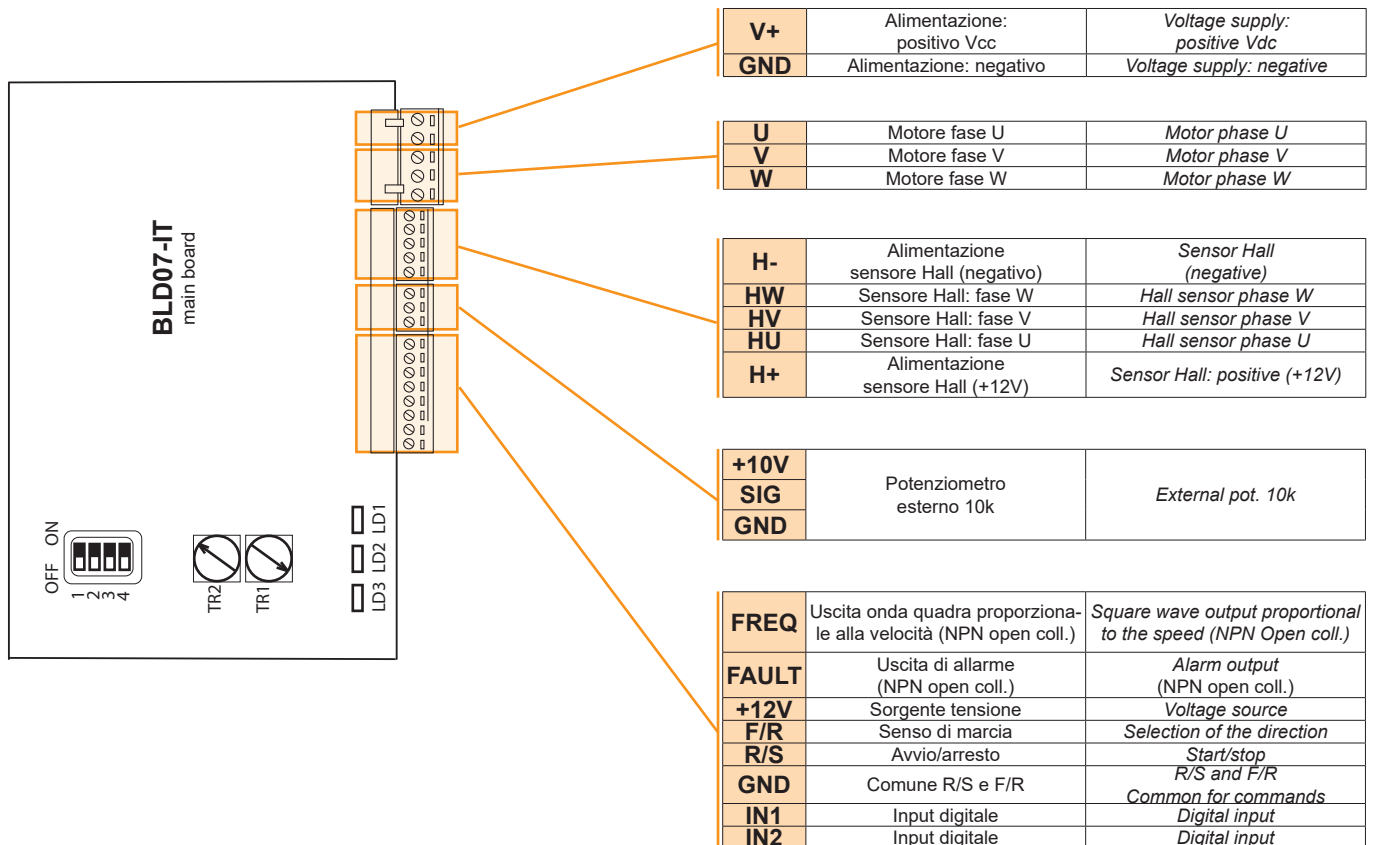



BLD07-IT

**AZIONAMENTO 4Q
PER MOTORI BRUSHLESS CC**

**4Q DRIVE
FOR DC BRUSHLESS MOTORS**

Collegamenti

Connections

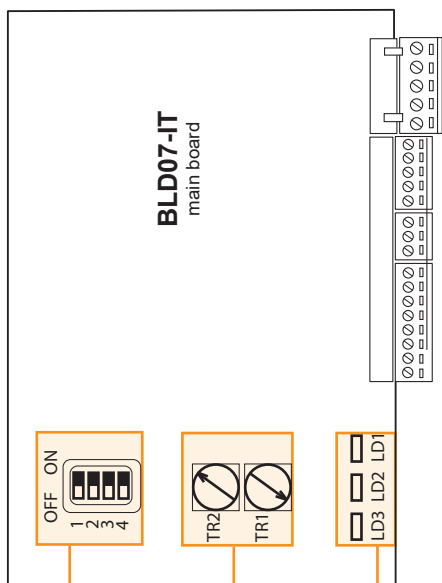

Led		
LD1	Verde - power ON	Green - power ON
LD2	Rosso - allarme in corso	Red - alarm
LD3	Giallo - superamento corrente max.	Yellow - the drive is in limit of current
	Presenti 2 Leds per la chiusura dei contatti R/S e F/R	2 LEDs for the closing of R/S and F/R

Trimmer		
TR1	Regolazione velocità (crescente con rotazione oraria)	External speed pot (clockwise to increase)
TR2	Limitazione corrente (crescente con rotazione antioraria)	Current limitation (counter clockwise to increase)

Dip Switch		
1	OFF = Controllo velocità da pot. interno TR1	Internal speed pot TR1
	ON = Controllo velocità da pot. esterno o segnale analogico 0/+10V	External speed pot or analog signal 0/+10V
2	OFF = Funzionamento in anello chiuso	Operating in closed loop
	ON = Funzionamento in anello aperto	Operating in open loop
3	OFF = Rampe rapide (0.1 s)	Fast Acceleration (about 0.1 sec)
	ON = Rampe lente (1.0 s)	Slow acceleration (about 1.0 sec)
4	OFF = per motori a 4 poli	4 poles motors
	ON = per motori a 8 poli	8 poles motors



BLD15

**AZIONAMENTO 4Q
PER MOTORI BRUSHLESS CC**

**4Q DRIVE
FOR DC BRUSHLESS MOTORS**

L'azionamento BLD15 è l'evoluzione sia in potenza che in controllo dell'azionamento BLD07-IT. La BLD15 è in grado di effettuare un controllo del motore brushless sia in coppia che in velocità con retroazione da sensori di Hall, la gestione in coppia o in velocità può avvenire con l'utilizzo di un segnale analogico o di un segnale digitale su network tramite i protocolli: ModBus RTU RS485 o CANOpen CIA301-CIA402.

The BLD15 drive is the evolution in both power and control of the BLD07-IT drive. The BLD15 is able to control the brushless motor both in torque and in speed with feedback from Hall sensors, the management in torque or in speed can have an analog signal or a digital signal on the network through the protocols: ModBus RTU RS485 or CANOpen CIA301-CIA402.

Caratteristiche standard

Standard features

- Azionamento bidirezionale rigenerativo
- Alimentazione singola CC
- 3 Leds per la diagnostica (stato ed allarmi)
- Protetto per corto circuito, min/max tensione, mancanza celle di Hall
- Protezione termica motore Ixt
- Connettori estraibili (segnali e potenza)
- Comando di velocità analogico 0 +10Vcc e PWM (2 kHz)
- 4 Ingressi digitali – optoisolati
- 2 Uscite NPN - allarmi e frequenza di lavoro
- Regolazione rampa di accelerazione
- Versione TORQUE control
- Versione ModBus RTU RS485
- Versione CANOpen CIA301-CIA402

- Bidirectional regenerative operation
- Single supply DC voltage
- 3 diagnostic Leds (State and Alarms)
- Protections for: Over/Under voltage, Over current, Hall missing
- Ixt motor current protection
- Power and signals extractable connectors
- Analog speed command 0 + 10Vdc and PWM (2 kHz)
- 4 Digital inputs – optoisolated
- 2 NPN - fault drive and running frequency
- Acceleration adjustment
- TORQUE control version
- ModBus RTU RS485 version
- CANOpen CIA301-CIA402 version

Dati tecnici principali

Specifications

- Idoneo per motori BLDC trifase 4/8 poli
- Retroazione digitale sensori di Hall
- Controllo motore in frequenza PWM 20 kHz
- Temperatura operativa 0/+40°C
- Ingresso analogico 0/+10Vcc
- Rampa accelerazione regolabile 0.1/1.0sec (tramite dip switch)
- Regolazione corrente max
- Regolazione della velocità (potenziometro esterno o interno) esterno 10KΩ

- Suitable for 3ph BLDC motors 4/8 poles
- Digital feedback Hall sensors
- Motor control in PWM frequency 20 kHz
- Operative temperature 0/+40°C
- Analog inputs range 0/+10Vdc
- Acceleration ramp adjustable 0.1/1.0sec (by dip switch)
- Current max regulation
- Speed change regulation (by external or internal pot) external 10KΩ

MODELLO / MODEL		BLD15
Tensione nominale motore <i>Motor DC Voltage</i>	(Vdc)	24 - 36 - 48
Tensione di alimentazione min / max <i>Supply DC Voltage Range min / max</i>	(Vdc)	20-65
Corrente nominale <i>Rated Current</i>	(A)	15
Corrente di picco (1) <i>Peak Current</i>	(A)	30
Potenza nominale (2) <i>Rated Power</i>	(W)	650
Potenza di picco (3) <i>Peak Power</i>	(W)	1300

(1) La corrente di picco viene erogata per un tempo di circa 2 secondi
(1) *Peak current (A_{dc}) for 2 sec.*

(2) La potenza nominale è riferita al valore di tensione e di corrente nominale
(2) *Power of amplifier at the rated current and rated voltage*

(3) La potenza di picco è riferita al valore di tensione nominale e di corrente di picco
(3) *Power of amplifier at the peak current and rated voltage*



BLD15

AZIONAMENTO 4Q
PER MOTORI BRUSHLESS CC

4Q DRIVE
FOR DC BRUSHLESS MOTORS

Dimensioni

Dimensions

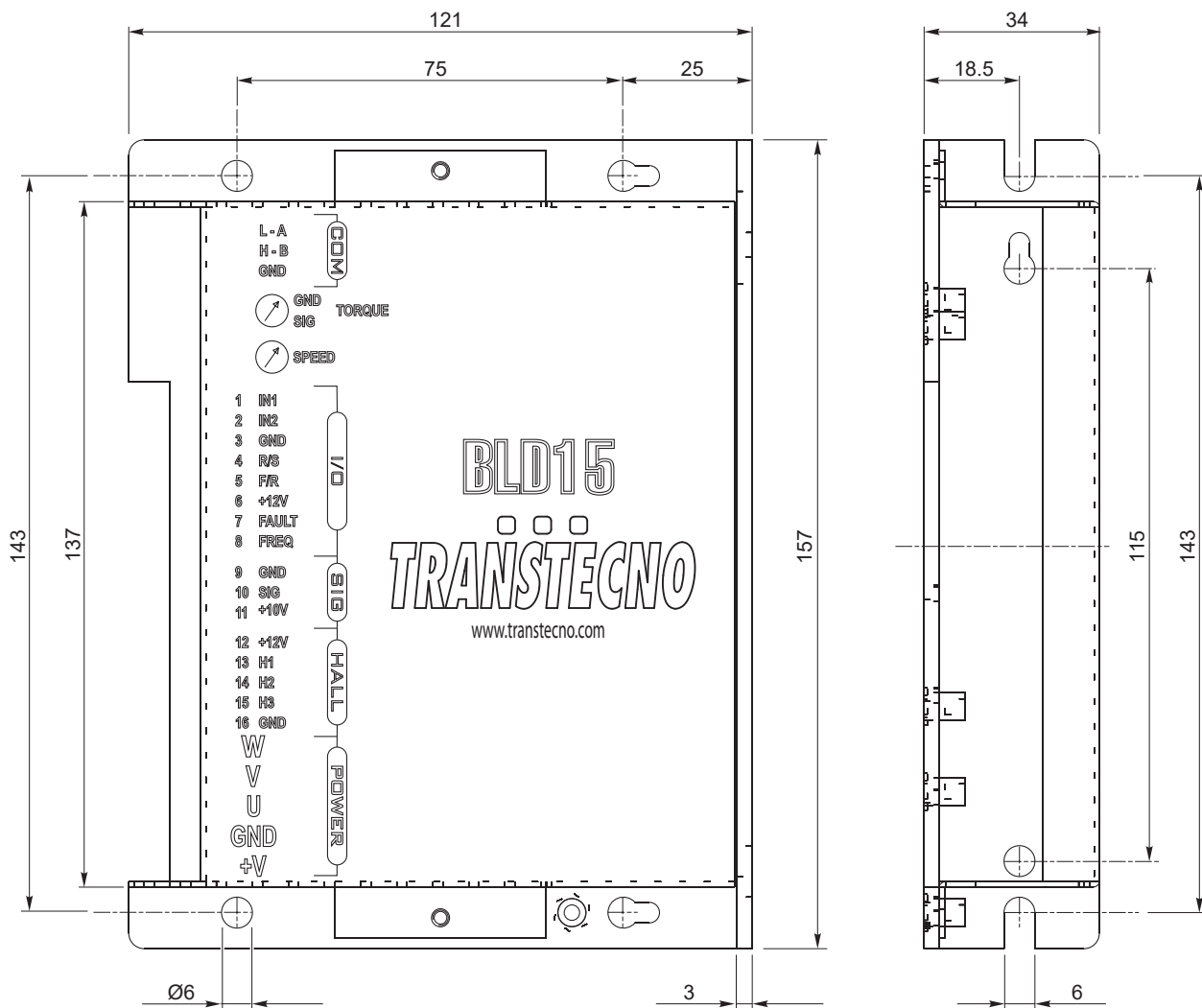



BLD15

**AZIONAMENTO 4Q
PER MOTORI BRUSHLESS CC**

**4Q DRIVE
FOR DC BRUSHLESS MOTORS**

Collegamenti

Connections

L'azionamento BLD15 è dotato di:

- connettore estraibile a 5 poli per la parte di potenza;
- tre connettori estraibili, per un totale di 16 morsetti, per la gestione dei segnali in ingresso ed in uscita.

Versione TORQUE

- connettore estraibile a 2 morsetti

Versione ModBus/CANOpen

- connettore estraibile a 3 morsetti

The BLD15 drive is equipped with:

- removable connector with 5 terminals for the power part;
- 3 removable connectors, for a total of 16 terminals, for the management of the input and output signal.

TORQUE Version

- removable connector with 2 terminals

ModBus/CANOpen Version

- removable connector with 3 terminals

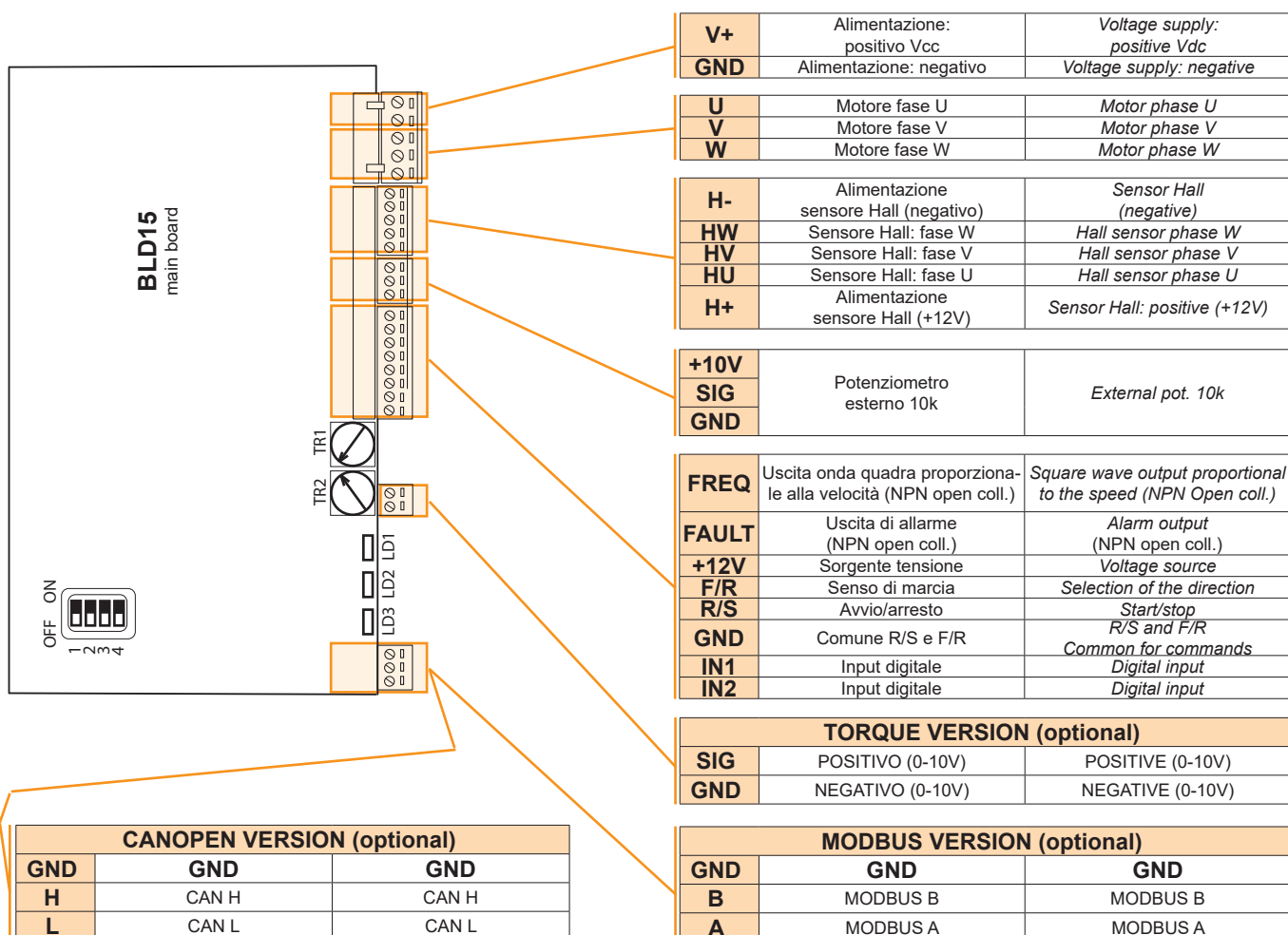



BLD15

**AZIONAMENTO 4Q
PER MOTORI BRUSHLESS CC**

**4Q DRIVE
FOR DC BRUSHLESS MOTORS**

Collegamenti

Connections

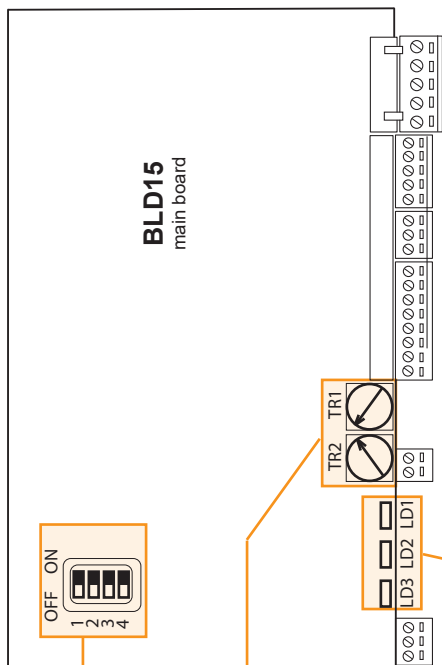

Led		
LD1	Verde - power ON	Green - power ON
LD2	Rosso - allarme in corso	Red - alarm
LD3	Giallo - superamento corrente max.	Yellow - the drive is in limit of current
Presenti 2 Leds per la chiusura dei contatti R/S e F/R		2 LEDs for the closing of R/S and F/R

Trimmer		Opzionale	Optional
TR1	Regolazione velocità (crescente con rotazione oraria)	Regolazione della rampa in accelerazione	Acceleration ramp adjustable
TR2*	Limitazione corrente (crescente con rotazione antioraria)	Regolazione della rampa in decelerazione	Deceleration ramp adjustable

(*) Non presente con versione torque
 (*) Not designed for torque version

Dip Switch		
1	OFF = Controllo velocità da pot. interno TR1	Internal speed pot TR1
	ON = Controllo velocità da pot. esterno o segnale analogico 0/+10V	External speed pot or analog signal 0/+10V
2	OFF = Funzionamento in anello chiuso	Operating in closed loop
	ON = Funzionamento in anello aperto	Operating in open loop
3	OFF = Rampe rapide (0.1 s)	Fast Acceleration (about 0.1 sec)
	ON = Rampe lente (1.0 s)	Slow acceleration (about 1.0 sec)
4	OFF = per motori a 4 poli	4 poles motors
	ON = per motori a 8 poli	8 poles motors



BLD60 DIGITAL

**AZIONAMENTO 4Q
PER MOTORI BRUSHLESS CC**

BLD60 Digital è un controller di velocità ad anello chiuso che utilizza componenti di potenza IGBT e MOSFET. Utilizza il segnale di Hall del motore brushless per eseguire il controllo della velocità ad anello chiuso, e riduce l'errore tramite il regolatore dei PID. E' in grado di raggiungere la coppia massima anche alle basse velocità da 150 a 4000 giri al minuto. Il drive utilizza il protocollo ModbusRS485 RTU per poter comunicare i parametri e gestire i motori su di un Network.

Caratteristiche standard

- **Azionamento trifase a quattro quadranti per motori Brushless**
- Alimentazione singola DC
- Display digitale (gestione azionamento e stato allarmi)
- Protetto per corto circuito, min/max tensione, sovratemperatura, mancanza celle di hall.
- Protezione termica
- Connettori estraibili 8 vie (segnali) e 5 vie (sensori di Hall).
- 1 Comando di velocità differenziale analogico +5V
- 1 Comando di coppia analogico +5V per realizzare avvitatori, svolgitori, macchine test, ecc
- Feedback da sensori di HALL
- 2 Uscita NPN segnalazione allarme azionamento feedback velocità
- 2 trimmer (gestione velocità e corrente).

Dati tecnici principali

- Idoneo per motori BLDC trifase 4/8 poli
- Retroazione digitale sensori di Hall
- Controllo motore in frequenza PWM 20 kHz
- Temperatura operativa 0/+40°C
- Ingresso analogico 0/5 Vcc
- Rampa accelerazione regolabile 0.1/10 sec (tramite display digitale)
- Regolazione corrente max
- Regolazione della velocità esterno 10kΩ (potenziometro esterno o interno)
- Controllo motore in digitale RS485

Dimensioni

BLD60 DIGITAL		48
Tensione nominale DC Voltage Supply	(V)	48
Tensione min / max DC Voltage Range	(V)	24 - 36 - 48
Corrente nominale Rated Current	(A)	50
Corrente di picco (1) Peak Current	(A)	75
Potenza nominale (2) Rated Power	(W)	1500
Potenza di picco (3) Peak Power	(W)	2120

- (1) La corrente di picco viene erogata per un tempo di circa 2 secondi
(1) *Peak current (A_{dc}) for 2 sec.*
- (2) La potenza nominale è riferita al valore di tensione e di corrente nominale
(2) *Power of amplifier at the rated current and rated voltage*
- (3) La potenza di picco è riferita al valore di tensione nominale e di corrente di picco
(3) *Power of amplifier at the peak current and rated voltage*

**4Q DRIVE
FOR DC BRUSHLESS MOTORS**

BLD30 Digital BLDC motor driver is a closed-loop speed controller, which uses IGBT and MOS power, uses the Hall signal of the DC brushless motor to perform double-loop speed control, and has a PID speed regulator in the control link. The system control is stable and reliable.

It can always reach the maximum torque at low speed, and the speed control range is 150 to 4000rpm. The driver use the protocol Modbus RS485 RTU to communicate in a network.

Standard characteristic

- **Four quadrant regenerative drive for Brushless motor**
- Single supply DC voltage
- Digital display (drive management and alarm status)
- Protections for: Over/Under voltage, max. temperature, Over current
- thermal protection
- signals extractable connectors (8 ways and 5 ways)..
- 1 Differential velocity input +5V
- 1 Torque mode (demand current) input +5V
- Feedback by HALL sensors
- 2 NPN output (feedback speed and fault)
- 2 Potentiometer (Speed, current)

Specifications

- Suitable for 3ph BLDC motors 4/8 poli
- Digital feedback Hall sensors
- Motor control in PWM frequency 20 kHz
- Operative temperature 0/+40°C
- Analog inputs range 0/5 Vdc
- Acceleration ramp adjustable 0.1/10 sec (by digital display)
- Current max regulation
- Speed change regulation external 10kΩ (by external or internal pot))
- Digital motor control RS485

Dimensions

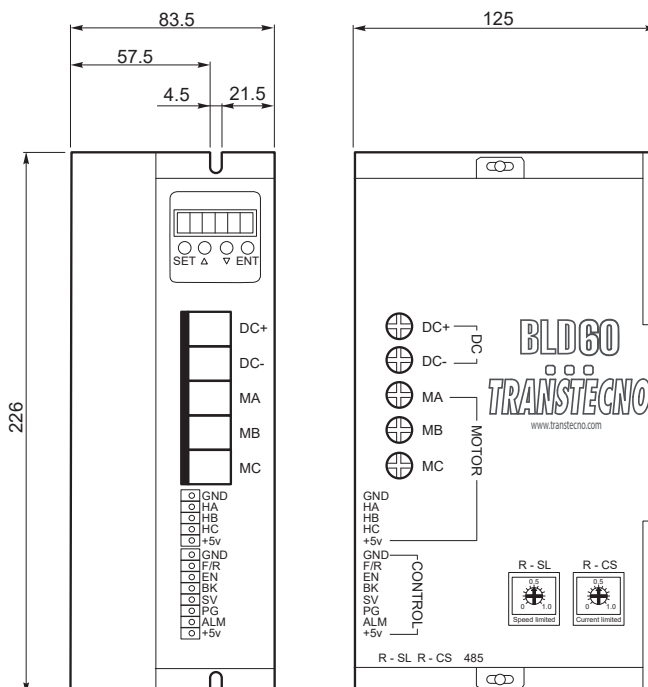



BLD60 DIGITAL

AZIONAMENTO 4Q PER MOTORI BRUSHLESS CC

4Q DRIVE FOR DC BRUSHLESS MOTORS

Collegamenti per motori brushless serie BL

Connections for brushless motors BL series

Fili di potenza:

- fase motore U: pin MA
- fase motore V: pin MB
- fase motore W: pin MC

Power wires:

- phase motor U: pin MA
- phase motor V: pin MB
- phase motor W: pin MC

Fili di segnale:

- Rosso piccolo (+Vcc): pin +5V
- Nero piccolo (GND): pin GND
- Blue (hall U): pin HA
- Verde (hall V): pin NB
- Bianco (hall W): pin HC

Fili di segnale:

- Red small (+Vdc): pin +5V
- Black small (GND): pin GND
- Blue (hall U): pin HA
- Green (hall V): pin HB
- White (hall W): pin HC

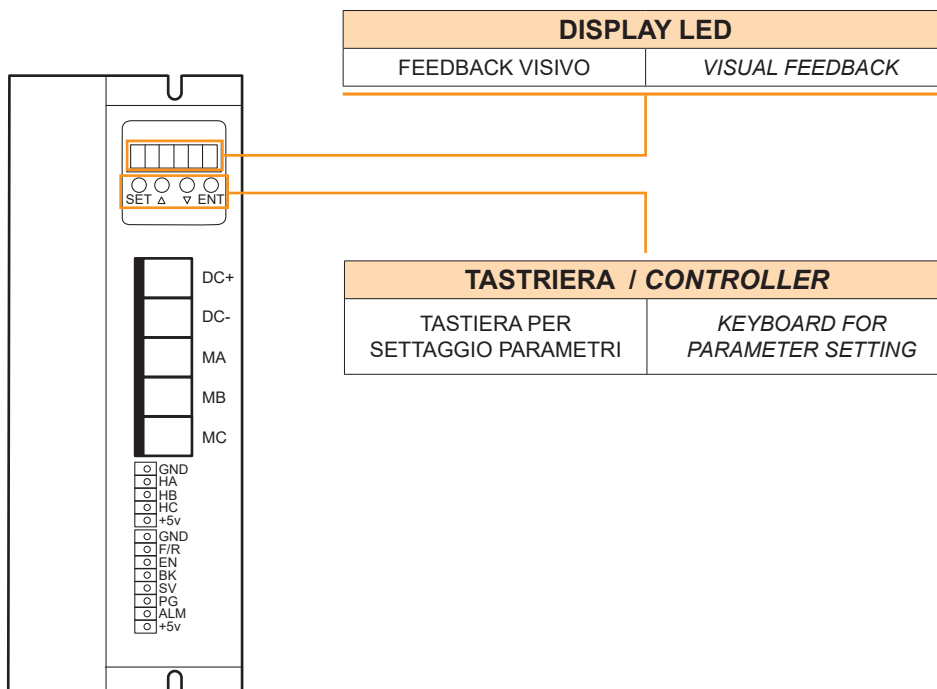
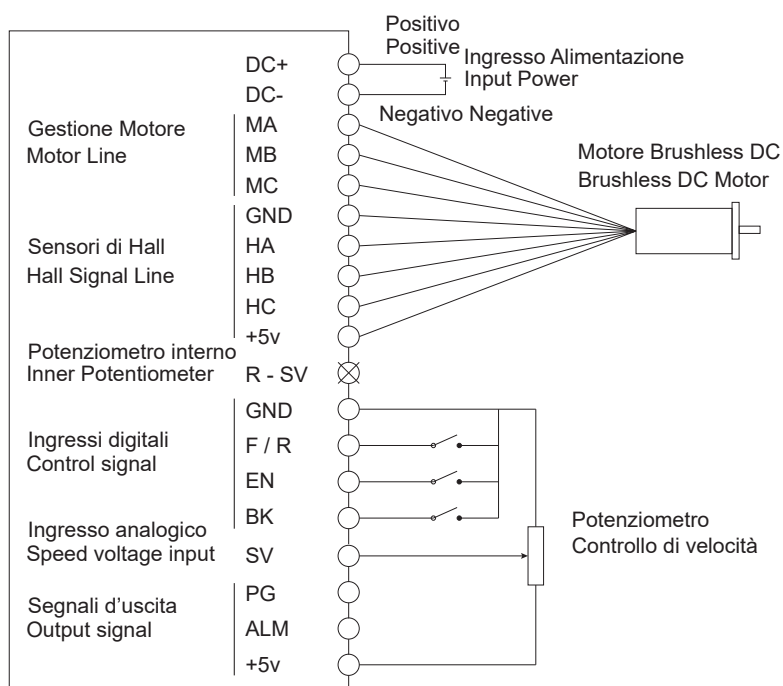

 **TRANSTECNO SRL**
HEADQUARTERS

Company subject to the management
and coordination of INTERPUMP GROUP SPA
Via Caduti di Sabbiano, 11
40011 Anzola dell'Emilia (BO)
ITALY
T +39 051 64 25 811
F +39 051 73 49 43
sales@transtecno.com
www.transtecno.com

**TRANSTECNO®**
the modular gearmotor

MEMBER OF INTERPUMP GROUP



**HANGZHOU INTERPUMP
POWER TRANSMISSIONS CO LTD**
No.4 Xiuyan Road Fengdu Industry Zone
Pingyao Town Yuhang District
Hangzhou City, Zhejiang Province
311115 – CHINA
T +86 571 86 92 02 60
info-china@transtecno.cn
www.transtecno.cn



**TRANSTECNO IBÉRICA
THE MODULAR GEARMOTOR, S.A.**
Carrer de la Ciència, 45
08840 Viladecans (Barcelona) - SPAIN
T +34 931 598 950
info@transtecno.es
www.transtecno.es



TRANSTECNO B.V.
Siliciumweg 32
3812 SX Amersfoort - NETHERLANDS
T +31(0) 33 45 19 505
info@transtecno.nl
www.transtecno.nl



TRANSTECNO AANDRIJFTECHNIEK B.V.
Siliciumweg 32
3812 SX Amersfoort - NETHERLANDS
T +31 (0) 33 20 4 7 006
info@transtecnoaandrijftechnik.nl
www.transtecnoaandrijftechnik.nl



MA TRANSTECNO S.A.P.I. DE C.V.
Julián Sepúlveda Dávila #107,
Parque Industrial SG
Apodaca, Nuevo León, CP. 66640
MÉXICO
T +52 8113340920
info@transtecno.com.mx
www.transtecno.com.mx



TRANSTECNO USA
8 Creek Parkway,
Boothwyn PA 19061-8136 - UNITED STATES
T + 1 (610) 4970154

TRANSTECNO USA – WEST COAST BRANCH
14561 Fryelands Blvd SE
Monroe, WA 98272 - UNITED STATES
T +1 360-863-1300
usaoffice@transtecno.com
www.transtecno.com



TRANSTECNO CANADA
51 B Caldari Road Unit 10
Vaughan, ON L4K 4G3 - CANADA
T +1 905 761 0762
canadaoffice@transtecno.com
www.transtecno.com



TRANSTECNO INDIA
#6A, Sipcot Industrial complex, Phase-1, Elasangiri Road
Hosur – 635126 Tamilnadu - INDIA
T +91 4344 274434
M +91 81443 88800



TRANSTECNO BRAZIL
Rua Gilberto de Zorzi, 525 Forqueta - CEP. 95115-730
CX Postal 3544 Caxias do Sul RS – BRAZIL

TRANSTECNO BRAZIL – SÃO PAULO BRANCH
Rua Fortunato Jose Deltreggia, 745 – CEP: 13347-441
Indaiatuba, São Paulo – BRAZIL
T +55 19 98927 3906

TRANSTECNO BRAZIL – PORTO ALEGRE BRANCH
Rua Dr. Freire Alemão 155 / 402 - CEP. 90450-060
Auxiliadora Porto Alegre RS - BRAZIL
T +55 51 4042 0916
M +55 51 811 45 962
braziloffice@transtecno.com
www.transtecno.com.br



INTERPUMP ANTRIEBSTECHNIK GMBH
Büro Stuttgart - Dieselstraße 6
70738 Fellbach - GERMANY
T +49 (0)171 4781909
germanoffice@transtecno.com
www.transtecno.com



TRANSTECNO AUSTRALIA
1/2 Access Way, CarrumDowns, Victoria, 3201
AUSTRALIA
T +61 (03) 9775 1077
australiaoffice@transtecno.com
www.transtecno.com



SALES OFFICE OCEANIA
Unit 5, 12 Nyholt Drive, Yatala 4207
Queensland - AUSTRALIA
T +61 07 3800 0103
M +61 04 38060997
oceaniaoffice@transtecno.com
www.transtecno.com.au