

**TRANSTECNO**<sup>®</sup>  
the modular gearmotor

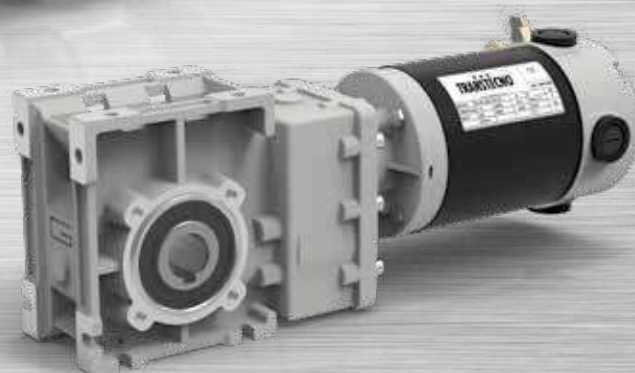

**Ott** Antriebstechnik  
Standardisierte Individualität

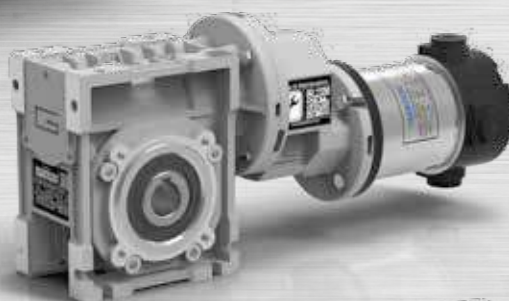

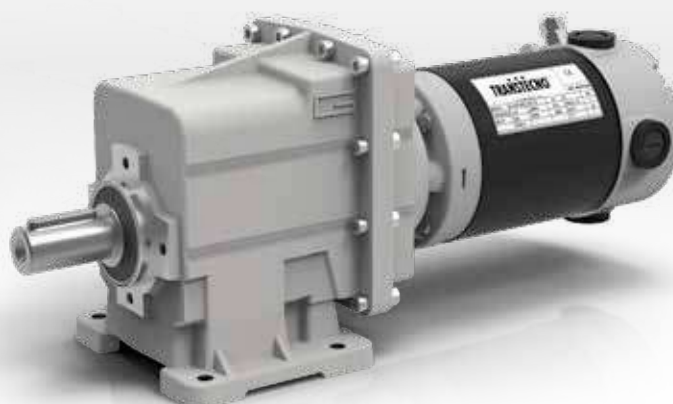

# Indice

# Index

Pag.  
Page

**A** Introduzione **Introduction** **A1**

 **B** Motori elettrici CC **DC Electric motors** **B1**  
**ND**

 **C** Motoriduttori CC ad ingranaggi cilindrici **DC Helical in-line gearmotors** **C1**  
**NDCMG**

 **D** Motoriduttori CC ad assi ortogonali **DC Helical bevel gearmotors** **D1**  
**NDCMB**

 **E** Motoriduttori CC pendolari **DC Helical parallel gearmotors** **E1**  
**NDFT**

 **F** Motoriduttori CC a vite senza fine **DC Wormgearmotors** **F1**  
**NDCM**

 **G** Motoriduttori CC a vite senza fine con precoppia **DC Pre stage wormgearmotors** **G1**  
**NDCMP**

 **H** Motoriduttori CC ad ingranaggi cilindrici monostadio **DC Single stage helical gearmotors** **H1**  
**NDPS**

 **I** Motori elettrici CC **DC Electric motors** **I1**  
**EC**

 **L** Motori elettrici CC in IP66 **IP66 DC Electric motors** **L1**  
**EC IP66**

 **M** Motoriduttori CC ad ingranaggi cilindrici **DC Helical in-line gearmotors** **M1**  
**ECMG**

 **N** Motoriduttori CC ad assi ortogonali **DC Helical bevel gearmotors** **N1**  
**ECMB**

 **O** Motoriduttori CC pendolari **DC Helical parallel gearmotors** **O1**  
**ECFT**

 **P** Motoriduttori CC a vite senza fine **DC Wormgearmotors** **P1**  
**ECM**

 **Q** Motoriduttori CC a vite senza fine con precoppia **DC Pre stage wormgearmotors** **Q1**  
**ECMP**

 **R** Motoriduttori CC a vite senza fine combinati **DC Double reduction wormgearmotors** **R1**  
**ECMM**

 **S** Motoriduttori CC ad ingranaggi cilindrici monostadio **DC Single stage helical gearmotors** **S1**  
**ECPS**

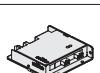
 **T** Azionamenti per motori CC **DC Motor controls** **T1**  
**PLN**

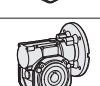
 **U** Motoriduttori a vite senza fine **Wormgearmotors** **U1**  
**CL**

Neodymium

Ferrite

Questo catalogo annulla e sostituisce ogni precedente edizione o revisione.  
Ci riserviamo inoltre il diritto di apportare modifiche senza preavviso.  
La versione più aggiornata è disponibile sul sito [www.transtecno.com](http://www.transtecno.com)

*This catalogue supersedes any previous edition and revision.  
We reserve the right to implement modifications without notice.  
The most updated version is available on our website  
[www.transtecno.com](http://www.transtecno.com)*



<b>Indice</b>	<b>Index</b>	Pag. Page
Generalità	<i>General information</i>	<b>A2</b>
Velocità entrata	<i>Input speed</i>	<b>A2</b>
Rapporto di riduzione	<i>Gear ratio</i>	<b>A2</b>
Velocità in uscita	<i>Output speed</i>	<b>A2</b>
Coppia richiesta	<i>Requested torque</i>	<b>A2</b>
Coppia nominale	<i>Nominal torque</i>	<b>A3</b>
Coppia trasmessa	<i>Output torque</i>	<b>A3</b>
Rendimento del riduttore a vite senza fine	<i>Worm gearbox efficiency</i>	<b>A3</b>
Reversibilità e irreversibilità	<i>Reversibility and irreversibility</i>	<b>A4</b>
Potenza in entrata	<i>Input power</i>	<b>A4</b>
Fattore di servizio	<i>Service factor</i>	<b>A5</b>
Carico radiale	<i>Radial load</i>	<b>A6</b>
Carico assiale	<i>Axial load</i>	<b>A6</b>
Scelta dei motoriduttori	<i>Selecting the gearmotors</i>	<b>A6</b>
Giunto elastico	<i>Flexible coupling</i>	<b>A7</b>
Installazione e verifiche	<i>Installation and inspection</i>	<b>A8</b>
Applicazioni critiche	<i>Critical applications</i>	<b>A8</b>

Questa sezione annulla e sostituisce ogni precedente edizione o revisione. Qualora questa sezione non Vi sia giunta in distribuzione controllata, l'aggiornamento dei dati ivi contenuto non è assicurato. **In tal caso la versione più aggiornata è disponibile sul nostro sito internet [www.transtecno.com](http://www.transtecno.com)**

*This section replaces any previous edition and revision. If you obtained this catalogue other than through controlled distribution channels, the most up to date content is not guaranteed. **In this case the latest version is available on our web site [www.transtecno.com](http://www.transtecno.com)***

## Generalità

Per avere una migliore comprensione degli argomenti e dei dati esposti in questo catalogo proponiamo la simbologia utilizzata corredandola delle informazioni di base per giungere ad una corretta selezione dei motoriduttori e variatori.

## General information

Information in this manual is provided with symbols in order to understand the subject matter and data. These symbols are intended to aid the user in selecting the right gearmotors and variators.

## Velocità entrata

$n_1$  [min<sup>-1</sup>]

## Input speed

Rappresenta la velocità riferita al tipo di motorizzazione prescelta ed è applicata in entrata al riduttore.

This is the input speed at the gearbox related to the type of drive unit selected.

Per selezioni a velocità diverse da quelle riportate consultare il ns. Servizio Tecnico.

When different speeds are required, contact our Technical Service.

## Rapporto di riduzione

$i$

## Gear ratio

È una grandezza adimensionale ed è in funzione del numero dei denti degli ingranaggi interni al riduttore.

This value is strictly related to the size and number of teeth gears inside the gearbox.

Nei riduttori a vite senza fine si ottiene dividendo il numero di denti della corona per il numero dei filetti (Z) della vite senza fine.

This value is obtained in wormgearboxes by dividing the number of wheel teeth by the number of starts (Z) of the worm.

Dai dati di catalogo si può ottenere con la relazione:

From the data given in the catalogue, the value can be calculated using the following formula:

$$i = \frac{n_1}{n_2}$$

## Velocità in uscita

$n_2$  [min<sup>-1</sup>]

## Output speed

È la velocità risultante sull'asse di uscita del riduttore e viene ricavata dalla relazione precedente:

This is the gearbox output speed calculated using the formula given above:

$$n_2 = \frac{n_1}{i}$$

## Coppia richiesta

$Mr_2$  [Nm]

## Requested torque

È la coppia richiesta dall'applicazione ed è indispensabile per la selezione di una motorizzazione.

This is the torque needed for the application and must be known when selecting a drive system. It can either be provided by the user or calculated according to the application data (if provided).

Essa può essere comunicata dall'utente oppure calcolata in base ai dati di applicazione (se forniti).

### Coppia nominale

$Mn_2$  [Nm]

### Nominal torque

Rappresenta la coppia in uscita trasmissibile dal riduttore in base alla velocità in entrata  $n_1$  e al rapporto di riduzione  $i$ . Essa è calcolata in base ad un servizio con carico continuo uniforme corrispondente ad un fattore di servizio uguale a 1. Questo valore non è riportato nel presente catalogo ma può essere ricavato approssimativamente con la seguente relazione fra  $M_2$  (coppia trasmessa) e  $sf$  (fattore di servizio):

*This is the output torque that can be transmitted by the gearbox according to input speed  $n_1$  and gear ratio  $i$ . It is calculated based on service with a continuous steady load corresponding to a service factor equal to 1. This value is not given in the catalogue but can be calculated approximately with the following formula between  $M_2$  (output torque) and  $sf$  (service factor):*

$$Mn_2 = M_2 \cdot sf$$

### Coppia trasmessa

$M_2$  [Nm]

### Output torque

È la coppia trasmessa in uscita al riduttore. Dipende dalla potenza  $P_1$  del motore installato, dal numero di giri in uscita  $n_2$  e dal rendimento dinamico  $Rd$  e può essere calcolata con la relazione:

*This is the gearbox's output torque. It is strictly related to power  $P_1$  of the motor installed, output rpm  $n_2$  and dynamic efficiency  $Rd$ . It can be calculated with the following formula:*

$$M_2 = \frac{9550 \cdot P_1 \cdot Rd}{n_2}$$

oppure:  
or:

$$M_2 = \frac{9550 \cdot P_2}{n_2}$$

dove:  
where:

$$P_2 = P_1 \cdot Rd$$

### Rendimento del riduttore a vite senza fine

$Rd; Rs$

### Worm gearbox efficiency

I calcoli delle prestazioni sono stati effettuati in base al rendimento dinamico  $Rd$  dei riduttori (valore ottimale che si raggiunge nel funzionamento a regime dopo rodaggio).

*Efficiency is calculated based on dynamic efficiency  $Rd$  of the gearboxes (optimal value reached when running at normal speed after the break in period).*

Nei riduttori combinati, il rendimento complessivo è dato dal prodotto dei rendimenti dei due riduttori, considerando però che nel secondo riduttore il rendimento dovrà essere valutato in base alla ridotta velocità in entrata ottenuta dividendo  $n_1$  per il rapporto  $i$  del primo riduttore.

*In combination gearboxes, overall efficiency is obtained from the combined efficiency of the two gearboxes. However, keep in mind that efficiency of the second gearbox should be determined according to the reduced input speed obtained by dividing  $n_1$  by ratio  $i$  of the first gearbox.*

È opportuno considerare che nei riduttori a vite senza fine si ha anche un valore di rendimento statico  $Rs$ , presente in fase di avviamento, che declassa sensibilmente la coppia risultante per cui influenza in modo determinante la scelta di motorizzazioni destinate ad applicazioni intermittenti (es. sollevamenti).

*It is important to remember that wormgearboxes also have static efficiency value  $Rs$  present at start-up. This value notably reduces the resulting torque. As a result, it must be taken into consideration when selecting drive systems for intermittent operations (e.g. lifting) as it is a determinant factor.*

Il valore dei rendimenti dinamico e statico dei riduttori a vite senza fine sono riportati nella tabella a pag. N4.

*Dynamic and static efficiency of wormgearboxes are given in the table on page N4.*

Nei riduttori ad ingranaggi CMG e CMB il rendimento medio è del 94%.

*On helical gearboxes CMG and CMB the average efficiency is 94%.*

Nei motovariatori il rendimento assume un valore di 0.85 alla velocità massima e decresce fino a 0.7 alla velocità minima.

*Efficiency is 0.85 at the highest speed decreasing to 0.7 at the lowest speed in motovariators.*

## Reversibilità e irreversibilità

La diretta conseguenza del rendimento (statico e dinamico) è la reversibilità del riduttore a vite senza fine che consiste nella possibilità di fare ruotare l'albero entrata tramite l'applicazione di una torsione più o meno accentuata sull'albero uscita.

L'impossibilità o la difficoltà ad effettuare l'azione sopra descritta, determina il grado di reversibilità (o irreversibilità) di un riduttore.

Questa caratteristica, molto significativa nei riduttori a vite senza fine, è influenzata da molteplici fattori quali angolo d'elica (quindi rapporto di trasmissione), lubrificazione, temperatura, finitura superficiale della vite senza fine, presenza di vibrazioni, ecc.

In applicazioni dove sono presenti delle traslazioni è necessario garantire una elevata reversibilità onde evitare che le inerzie delle masse in movimento possano determinare punte di carico inammissibili sugli organi di trasmissione.

In applicazioni dove è richiesto un non ritorno del carico (es. sollevamenti o nastri trasportatori inclinati) in assenza di un freno motore è necessario scegliere un riduttore caratterizzato da un elevato grado di irreversibilità.

**Desideriamo comunque evidenziare che la garanzia assoluta di non ritorno è data esclusivamente dall'installazione di un motore autofrenante o di un altro dispositivo frenante esterno.**

La tabella sottostante riporta a titolo puramente indicativo i vari gradi di reversibilità/irreversibilità nei riduttori a vite senza fine in funzione del rendimento dinamico Rd e statico Rs.

## Reversibility and irreversibility

*Reversibility of the wormgearbox is the direct consequence of efficiency (static and dynamic). This determines whether or not the input shaft can be rotated by applying a certain torque on the output shaft.*

*Whether or not this can be done and how difficult it actually is to do determine the degree of reversibility (or irreversibility) of a gearbox.*

*This feature, quite significant in wormgearboxes, is affected by numerous factors including the helix angle (therefore drive ratio), lubrication, temperature, surface finish of the worm, vibrations, etc...*

*In applications that include translations, high reversibility must be guaranteed to prevent inertia of the moving parts from creating unacceptable load peaks on the drive parts.*

*In applications that require non-return of the load (e.g. lifting or inclined conveyor belts) a gearbox with high irreversibility must be chosen when a motor-brake unit is not present.*

**However, we would like to point out that non-return can be totally assured only by installing a self-braking motor or other external braking device.**

*The table below is provided for reference purposes only. It contains the various degrees of reversibility/irreversibility of wormgearboxes in relation to dynamic Rd and static Rs efficiency.*

Rd	Reversibilità e irreversibilità dinamica	Dynamic reversibility and irreversibility
> 0.6	Reversibilità dinamica	Dynamic reversibility
0.5 - 0.6	Reversibilità dinamica incerta	Uncertain dynamic reversibility
0.4 - 0.5	Buona irreversibilità dinamica	Good dynamic irreversibility
<0.4	Irreversibilità dinamica	Dynamic irreversibility
Rs	Reversibilità e irreversibilità statica	Static reversibility and irreversibility
> 0.55	Reversibilità statica	Static reversibility
0.5 - 0.55	Reversibilità statica incerta	Uncertain static reversibility
<0.5	Irreversibilità statica	Static irreversibility

## Potenza in entrata

$P_1$  [kW]

## Input power

È la potenza motore applicata in entrata al riduttore e riferita alla velocità  $n_1$ .

Può essere calcolata come segue:

*This is the power applied by the motor at the gearbox input in reference to speed  $n_1$ .*

*It can be calculated with the following formula:*

$$P_1 = \frac{M_2 \cdot n_2}{9550 \cdot Rd}$$

Fattore di servizio

sf

Service factor

È una grandezza adimensionale che indica il sovradimensionamento da applicare ad una determinata motorizzazione per garantire la resistenza agli urti e la durata richiesta.

Le tabelle di catalogo offrono una vasta scelta di motorizzazioni con fattori di servizio differenziati che possono soddisfare la maggior parte delle applicazioni più o meno gravose.

Per una corretta interpretazione dei valori del fattore di servizio sf riportati a fianco di ogni selezione proposta, riportiamo nelle tabelle seguenti i valori indicativi attribuiti alle classi di carico A, B, C e alla durata di funzionamento giornaliero h/d e al numero di avviamenti/ora.

Definendo la classe di carico a cui riferire l'applicazione, si ricercherà nella tabella il corrispondente valore di sf da utilizzare nella scelta della motorizzazione più idonea.

This value indicates how a certain drive system is to be over-sized in order to assure the requested service and stand up to shocks.

The tables given in the catalogue offer a wide range of drive systems with different service factors able to satisfy most types of applications. To correctly understand service factor values sf given for each item, approximate values for load classes A, B and C along with the number of hours of daily operation h/d and number of start-ups/hours need to be known.

Once the load class required for the application has been determined, locate corresponding value sf to be used when selecting the most suitable drive system.

<b>A - Uniforme</b>	$fa \leq 0.3$
<b>B - Medio</b>	$fa \leq 3$
<b>C - Forte</b>	$fa \leq 10$

<b>A - Uniform</b>	$fa \leq 0.3$
<b>B - Moderate shocks</b>	$fa \leq 3$
<b>C - Heavy shocks</b>	$fa \leq 10$

$fa = \frac{Je}{Jm}$

- Je (kgm<sup>2</sup>) momento d'inerzia esterno ridotto all'albero motore.
- Jm (kgm<sup>2</sup>) momento d'inerzia motore.

Se  $fa > 10$  interpellare il ns. Servizio Tecnico.

$fa = \frac{Je}{Jm}$

- Je (kgm<sup>2</sup>) moment of reduced external inertia at the drive-shaft.
- Jm (kgm<sup>2</sup>) moment of inertia of motor.

If  $fa > 10$  call our Technical Service.

**A** Classe di carico / Load class  
**Carico uniforme / Uniform load**

sf										
h/d	n. avviamenti/ora / n. start-up/hour									
	2	4	8	16	32	63	125	250	500	
4	0.8	0.8	0.9	0.9	1.0	1.1	1.1	1.2	1.2	
8	1.0	1.0	1.1	1.1	1.3	1.3	1.3	1.3	1.3	
16	1.3	1.3	1.3	1.3	1.5	1.5	1.5	1.5	1.5	
24	1.5	1.5	1.5	1.5	1.8	1.8	1.8	1.8	1.8	

**B** Classe di carico / Load class  
**Carico con urti moderati / Moderate shock load**

sf										
h/d	n. avviamenti/ora / n. start-up/hour									
	2	4	8	16	32	63	125	250	500	
4	1.0	1.0	1.0	1.0	1.3	1.3	1.3	1.3	1.3	
8	1.3	1.3	1.3	1.3	1.5	1.5	1.5	1.5	1.5	
16	1.5	1.5	1.5	1.5	1.8	1.8	1.8	1.8	1.8	
24	1.8	1.8	1.8	1.8	2.2	2.2	2.2	2.2	2.2	

**C** Classe di carico / Load class  
**Carico con urti forti / Heavy shock load**

sf										
h/d	n. avviamenti/ora / n. start-up/hour									
	2	4	8	16	32	63	125	250	500	
4	1.3	1.3	1.3	1.3	1.5	1.5	1.5	1.5	1.5	
8	1.5	1.5	1.5	1.5	1.8	1.8	1.8	1.8	1.8	
16	1.8	1.8	1.8	1.8	2.2	2.2	2.2	2.2	2.2	
24	2.2	2.2	2.2	2.2	2.5	2.5	2.5	2.5	2.5	

Esempio applicazione:

Nastro trasportatore attribuibile alla classe di carico B (**carico con urti moderati**) e previsto per una durata di funzionamento giornaliero (h/d) di **16** ore e con **8** avviamenti/ora. Dalla tabella rileviamo **sf = 1.5**

Application example:

Conveyor belt assigned to load class B (**moderate shock load**), to be run **16** hours a day (h/d) with **8** start-ups/hour. The following value is obtained from the table **sf = 1.5**

## Carico radiale

**R; R<sub>2</sub> [N]**

## Radial load

L'applicazione sull'albero in uscita del riduttore di pignoni, pulegge, ecc. determina delle forze radiali che debbono necessariamente essere considerate per evitare sollecitazioni eccessive con il rischio di danneggiamenti del riduttore stesso.

Il calcolo del carico radiale esterno R agente sull'albero del riduttore può essere determinato come segue:

*Pinions, pulleys, etc applied on the output shaft of the gearboxes create radial forces that must be taken into consideration to avoid excessive stress risking damage to the gearbox itself.*

*External radial load R that acts on the gearbox shaft can be calculated as follows:*

$$R = \frac{2000 \cdot M_2 \cdot kr}{d} \leq R_2$$

dove:

**d [mm]** diametro primitivo del pignone o della puleggia

**kr** coefficiente riferito al tipo di trasmissione:

**kr = 1.4** ruota per catena

**kr = 1.1** ingranaggio

**kr = 1.5 - 2.5** puleggia per cinghia a V

where:

**d [mm]** diameter of the pinion or pulley

**kr** coefficient in relation to type of transmission:

**kr = 1.4** sprocket wheel

**kr = 1.1** gear

**kr = 1.5 - 2.5** pulley for V belts

È opportuno evidenziare che i valori di R<sub>2</sub> sono riferiti a carichi agenti sulla mezzeria dell'albero lento (considerando l'albero sporgente) per cui il confronto dovrà essere effettuato nelle medesime condizioni.

*Keep in mind that values R<sub>2</sub> refer to loads that act on the center-line of the output shaft (considering the shaft protrudes). As a result, the value should be compared under the same conditions.*

## Carico assiale

**A; A<sub>2</sub> [N]**

## Axial load

A volte, unitamente al carico radiale, può essere presente anche una forza A che agisce assialmente sull'albero uscita; in questo caso considerare che il carico assiale ammissibile A<sub>2</sub> sull'albero è da considerare:

*At times, along with the radial load, force A may be present that acts axially on the output shaft. In this case, keep in mind allowable axial load A<sub>2</sub> that can be applied on the shaft is:*

$$A_2 = R_2 \cdot 0.2$$

Nel caso in cui il valore del carico assiale A agente sull'albero risultasse superiore ad A<sub>2</sub> contattate il ns. Servizio Tecnico.

*If axial load A that acts on the shaft is greater than A<sub>2</sub>, contact the Technical Service.*

## Scelta dei motoriduttori

## Selecting the gearmotors

Per la scelta di un motoriduttore è necessario seguire la seguente procedura.

*To select the required gearmotor perform the procedure below:*

1. Per l'applicazione desiderata ricavare il fattore di servizio sf dalle tabelle a pag. A5 in base alla classe di carico, alle ore di funzionamento giornaliere e al numero di avviamenti orari.

*1. Determine the service factor sf for the desired application by referring to the charts given on page A5. This is to be done by considering the class of load, the operational hours/day and the number of start-ups/ hour.*

2. Se si conosce la potenza motore P<sub>1</sub> [kW] richiesta, passare al punto 3); se è nota la coppia in uscita M<sub>2</sub> richiesta è necessario calcolare la potenza motore P<sub>1</sub> con la formula:

*2. If the required motor power output P<sub>1</sub> [kW] is known, go to item 3); if the required output torque M<sub>2</sub> is known, determine motor output P<sub>1</sub> by using the following formula:*

$$P_1 = \frac{M_2 \cdot n_2}{9550 \cdot Rd}$$

dove Rd è il rendimento dinamico e n<sub>2</sub> il numero di giri richiesti in uscita al motoriduttore.

*where Rd stands for the dynamic efficiency and n<sub>2</sub> indicates the required output rpm of the gearmotor.*

3. Nelle tabelle dei dati tecnici ricercare la motorizzazione in cui sia  $P_1$  maggiore o uguale a  $P$  e con riferimento ad una velocità  $n_2/n_{2max}$  prossima a quella desiderata, scegliere la motorizzazione in cui il fattore di servizio  $sf$  indicato risulti uguale o superiore a quello ricavato al punto 1).

3. Use the specification chart to search for the power unit where  $P_1$  is greater than or equal to  $P$  with a speed  $n_2/n_{2max}$  that approximates the desired one. Choose a power unit where the indicated service factor  $sf$  is equal to or greater than that calculated at point 1).

## ECM

$P_1$ [W]	$n_2$ [min <sup>-1</sup> ]	$M_2$ [Nm]	sf	i		Versione motore Motor version
<b>140</b>						
(3000 min <sup>-1</sup> )	<b>600</b>	2.0	5.0	5	<b>ECM100/026</b>	120/240/24E
	<b>400</b>	2.9	3.8	7.5		
	<b>300</b>	3.8	2.9	10		
	<b>200</b>	5.5	2.0	15		
	<b>150</b>	7.1	1.5	20		
	<b>100</b>	10	1.2	30		
	<b>75</b>	12	0.9	40		
	<b>60</b>	14	0.7	50		
	<b>50</b>	13	0.7	60		

Esempio / Example:

### Applicazione / Application:

Carrello automatico / Automatic carriage

$P_1$  : 140 W  
sf : 1.5  
 $n_2$  : 150 min<sup>-1</sup>

Motorizzazione scelta / Power unit selected:

**ECM100/026, i = 20,  $P_1$  = 140 W, sf = 1.5**

## ECMP

$P_1$ [W]	$n_2$ [min <sup>-1</sup> ]	$M_2$ [Nm]	sf	i		Versione motore Motor version
<b>250</b>						
(3000 min <sup>-1</sup> )	<b>50</b>	35	2.3	60	<b>ECMP180/063/050</b>	120/240/24E
	<b>40</b>	42	1.8	75		
	<b>33</b>	48	2.1	90		
	<b>25</b>	58	1.5	120		
	<b>20</b>	69	1.2	150		
	<b>17</b>	77	1.0	180		
	<b>13</b>	90	0.8	240		

Esempio / Example:

### Applicazione / Application:

Carrello automatico / Automatic carriage

$M_2$  : 58 Nm  
sf : 1.5  
 $n_2$  : 25 min<sup>-1</sup>

Motorizzazione scelta / Power unit selected:

**ECMP180/063/050, i = 120,  $P_1$  = 250 W, sf = 1.5**

## Giunto elastico

L'accoppiamento al motore tramite giunto elastico a morsetto ha i seguenti vantaggi:

- Maggiore rigidità torsionale;
- Smorzamento delle vibrazioni;
- Smorzamento dei picchi d'inerzia del motore;
- Eliminazione dell'ossidazione tra l'albero motore ed il manicotto per tribocorrosione;
- Temperatura di funzionamento inferiore;
- Facilità di smontaggio del motore anche dopo lunghi periodi di utilizzo;
- Evita il danneggiamento della linguetta del motore per servizio altamente intermittente.

## Flexible coupling

Motor connection by clamp flexible coupling allows the following benefits:

- Increasing torsional rigidity;
- Reducing vibrations;
- Cushioning motor start up jerks;
- Eliminates fretting corrosion phenomenon between motor sleeve and electric motor shaft;
- Lowering operating temperature;
- Easy disassembly of the motor after long periods of use;
- Avoid the damage of the key of the motor for highly intermittent duty

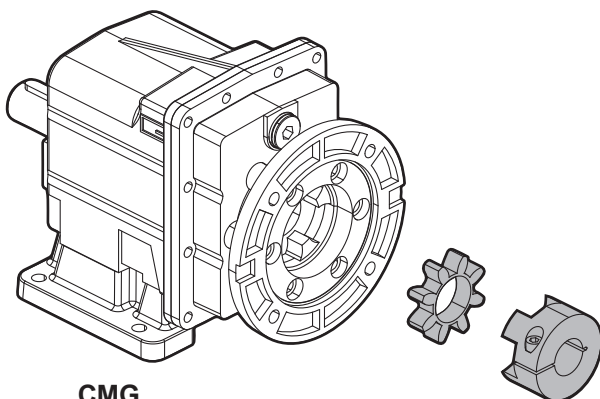

CMG...

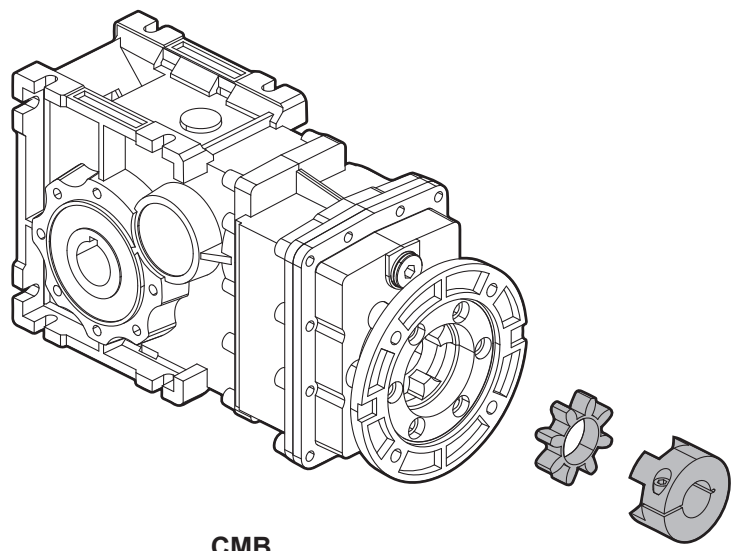

CMB...

## Installazione e verifiche

In fase di installazione del motoriduttore è opportuno verificare che:

- i dati riportati in targhetta corrispondano al prodotto che è stato ordinato;
- le superfici di accoppiamento e gli alberi siano accuratamente puliti e privi di ammaccature;
- le superfici su cui verrà installato il riduttore siano perfettamente piane e sufficientemente rigide;
- l'albero macchina e quello del riduttore siano correttamente allineati;
- siano stati installati sistemi di limitazione della coppia se si prevedono urti o blocchi della macchina durante il funzionamento;
- siano state predisposte le necessarie protezioni antinfortunistiche agli organi rotanti;
- siano state create delle opportune coperture a protezione dagli agenti atmosferici se l'installazione è effettuata all'aperto ed è soggetta alle intemperie;
- l'ambiente di lavoro non sia corrosivo (a meno che tale specifica non sia stata dichiarata in fase di ordine al fine di predisporre il riduttore per questo utilizzo);
- gli eventuali pignoni o pulegge montati sull'albero uscita o entrata del riduttore, siano calettati correttamente in modo tale da non generare carichi radiali e/o assiali superiori a quelli ammissibili;
- su tutti gli accoppiamenti sia stato applicato un adeguato protettivo antiossidante per prevenire eventuali ossidazioni da contatto;
- tutte le viti di fissaggio siano state serrate correttamente.

## Installation and inspection

*While installing the gearmotor always make sure that:*

- *the specifications stamped on the rating plate match those indicated for the unit actually ordered;*
- *the mating surfaces and the shafts are thoroughly clean and free of dents;*
- *the surfaces where the gearbox are to be mounted on are flat and strong enough;*
- *the machine drive shaft and the gearbox shaft are perfectly aligned;*
- *the required torque limiters have been installed if the machine is likely to produce shocks or blockages during operation;*
- *the rotary parts have been provided with the required safety guards;*
- *adequate weatherproof covering has been provided if the machine is to be installed outdoor;*
- *the working environment is not exposed to corrosive agents (unless this has been indicated while placing the order so that the gearbox assembly can be adequately set up);*
- *the pinions or pulleys on the gearbox input/output shafts are properly fitted in order not to produce radial and/or axial loads that exceed the maximum allowable limits;*
- *all the couplings have been treated with adequate rust preventative in order to avoid oxidation provoked by contact;*
- *all the mounting screws have been securely tightened.*

## Applicazioni critiche

In tutti questi casi consultare il Servizio Tecnico

- utilizzo come organo di sollevamento;
- utilizzo in posizioni non previste a catalogo;
- utilizzo in ambiente con pressione diversa da quella atmosferica;
- utilizzo in ambiente con temperature  $<0^{\circ}\text{C}$  o  $>+40^{\circ}\text{C}$
- utilizzo in ambienti esterni
- servizio continuo o altamente intermittente
- utilizzo in applicazioni con forti inerzie

## Critical applications

*In these cases please contact the Technical Service*

- *used as a hoist;*
- *used in mounting positions not shown in the catalogue;*
- *used in environment pressure other than atmospheric pressure;*
- *used in places with temperature  $<0^{\circ}\text{C}$  or  $>+40^{\circ}\text{C}$*
- *when used outdoors*
- *continuous or highly intermittent duty*
- *used in applications with high inertia*



Neodymium

**Motori elettrici CC**  
**DC electric motors**





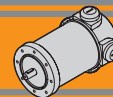

	<b>Indice</b>	<b>Index</b>	Pag. Page
	Caratteristiche tecniche	<i>Technical Features</i>	<b>B2</b>
	Grado di protezione IP	<i>IP enclosures protection indexes</i>	<b>B3</b>
	Classe di isolamento termico	<i>Insulation class</i>	<b>B3</b>
	Tipi di servizio IEC	<i>IEC duty cycle ratings</i>	<b>B3</b>
<b>ND120.120</b>	Caratteristiche	<i>Features</i>	<b>B4</b>
<b>ND120.240</b>	Dimensioni	<i>Dimensions</i>	<b>B4</b>
	Prestazioni	<i>Performances</i>	<b>B5</b>
<b>ND180.120</b>	Caratteristiche	<i>Features</i>	<b>B6</b>
<b>ND180.240</b>	Dimensioni	<i>Dimensions</i>	<b>B6</b>
	Prestazioni	<i>Performances</i>	<b>B7</b>
	Legenda / Glossario dei grafici	<i>Key / Diagram Glossary</i>	<b>B8</b>
	Formule utili	<i>Useful formulas</i>	<b>B8</b>
	Freni	<i>Brakes</i>	<b>B9</b>
	Encoder	<i>Encoder</i>	<b>B9</b>

Questa sezione annulla e sostituisce ogni precedente edizione o revisione. Qualora questa sezione non Vi sia giunta in distribuzione controllata, l'aggiornamento dei dati ivi contenuto non è assicurato. **In tal caso la versione più aggiornata è disponibile sul nostro sito internet [www.transtecno.com](http://www.transtecno.com)**

*This section replaces any previous edition and revision. If you obtained this catalogue other than through controlled distribution channels, the most up to date content is not guaranteed. In this case the latest version is available on our web site [www.transtecno.com](http://www.transtecno.com)*

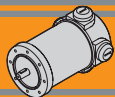

## Caratteristiche tecniche

I magneti in Neodimio (NdFeB) fanno parte dei magneti a terre rare e sono attualmente i magneti più potenti in produzione. Dotati di alta forza coercitiva (resistenza alla smagnetizzazione) ed alto valore di saturazione magnetica, sono in grado di immagazzinare moltissima energia magnetica. Pertanto, i motori CC dotati di magneti in Neodimio forniscono alti valori di coppia pur in dimensioni ridotte, grazie all'alta densità di flusso del campo magnetico.

Le caratteristiche principali dei motori elettrici CC a magneti permanenti in neodimio ND sono:

- Campo magnetico generato da magneti permanenti in Neodimio ( NdFeB )
- Costruzione tubolare senza ventilazione
- Disponibili in una grandezza diametro 65
- Alimentazione a bassa tensione 12 o 24 Vcc
- Potenza 160W e 250W S2
- Elevata coppia di spunto
- Maggiori coppie e potenze rispetto ai corrispettivi motori a magneti permanenti standard (a parità di dimensioni)
- Predisposizione encoder / freno

### Classe di isolamento termico

Gli avvolgimenti del rotore sono soggetti a surriscaldamento, come pure altre parti del motore. Il grado di isolamento indica la massima temperatura ammissibile oltre la quale l'isolante della matassa e l'isolante di tutte le parti soggette ad elevato riscaldamento perde le caratteristiche di buon isolante, con pericolo di danneggiamento del motore.

### Servizio

Rappresenta la relazione tra il tempo di lavoro ed il tempo di riposo del motore. Servizio continuo (S1) = funzionamento continuo del motore a pieno carico.

Servizio intermittente (S2, S3, etc...) = periodi alternati di lavoro e di riposo tali da raffreddare il motore. Dato un motore, la potenza espressa per servizio continuo è inferiore a quella per servizio intermittente.

### Fattore di forma

Indica quanta componente spuria alternata è presente nella alimentazione CC del motore. Più alto è il fattore ed inferiore è l'efficienza del motore. Alimentatori ad SCR = F.F 1.40. Alimentazione pura da batteria = FF 1 Alimentazione da transistori (modulazione PWM) = FF 1.05.

Qualitativamente l'andamento della coppia (percentuale) rispetto al fattore di forma è indicato nel grafico seguente:

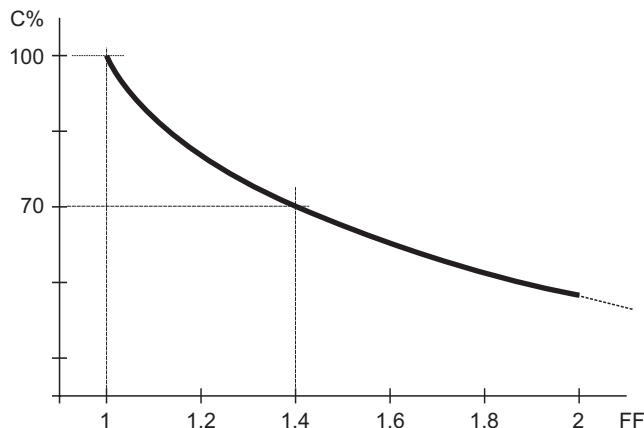

## Technical features

*Neodymium magnet (NdFeB) is a type of rare-earth magnet and is currently the strongest type of permanent magnets. Due to high coercivity resistance to being demagnetized and high saturation magnetization, they have potential for storing large amounts of magnetic energy. Therefore permanent Neodymium magnets DC motors can provide high torque in compact size due to the high density flux of magnet field.*

*The main features of ND neodymium permanent magnets DC electric motors range are:*

- *Magnetic field generated by Neodymium ( NdFeB ) permanent magnets*
- *Tubular construction without fan*
- *Available in one size diameter 65*
- *Low voltage power supply 12 or 24 Vdc*
- *Power ratings available 160W and 250W S2*
- *High starting torque*
- *Higher torque and higher power than standard permanent magnet D.C. motors.*
- *Suitable for encoder / brake assembly*

### Thermal insulation class

*The windings of the rotor can overheat just like other parts of the motor too. The degree of insulation indicates the maximum allowable temperature above which the insulation of the windings, as well as that of all the parts which heat up to a high temperature, loses its insulating properties and the motor therefore risks being damaged.*

### Duty cycle

*This represents the relationship between the time the motor operates and the time it remains stationary. Continuous operation (S1) = the motor operates non-stop under full load.*

*Intermittent operation (S2, S3, etc.) = alternating periods of work and rest so that the motor can cool down. The output power for continuous operation is lower than that for intermittent operation.*

### Form factor

*It indicates how much spurious alternating current is present in the D.C. motor power supply. The higher the factor, the lower the motor's efficiency. SCR power supplies = F.F 1.40. Battery supply = FF 1 Transistor supply (PWM modulation) = FF 1.05.*

*The graph below indicates the torque trend (percentage) in relation to the form factor:*

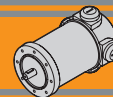

**Grado di protezione IP**

**IP enclosures protection indexes**

Indica il grado di isolamento meccanico del corpo motore.

Indicates the degree of mechanical insulation of the motor body.

1ª cifra: protezione alla penetrazione di corpi solidi.

1<sup>st</sup> figure: indicating level of protection against the penetration of solid bodies.

2ª cifra: protezione contro la penetrazione d'acqua.

2<sup>nd</sup> figure: indicating degree to which the motor is waterproof.

<b>0</b>	Non protetto / No protection	<b>0</b>	Non protetto / No protection
<b>1</b>	Protetto da corpi solidi superiori a Ø 50 mm. <i>Protected against solid matters (over Ø 50 mm)</i>	<b>1</b>	Protetto contro la caduta verticale di gocce d'acqua. <i>Protected against drops of water falling vertically</i>
<b>2</b>	Protetto da corpi solidi superiori a Ø 12 mm. <i>Protected against solid matters (over Ø 12 mm)</i>	<b>2</b>	Protetto contro la caduta verticale di gocce d'acqua con inclinazione max di 15° <i>Protected against drops of water falling up to 15°</i>
<b>3</b>	Protetto da corpi solidi superiori a Ø 2.5 mm. <i>Protected against solid matters (over Ø 2.5 mm)</i>	<b>3</b>	Protetto contro la pioggia. <i>Rain proof fixture</i>
<b>4</b>	Protetto da corpi solidi superiori a Ø 1 mm. <i>Protected against solid matters (over Ø 1 mm)</i>	<b>4</b>	Protetto contro gli spruzzi. <i>Splash proof fixture</i>
<b>5</b>	Protetto contro la polvere <i>Dust proof</i>	<b>5</b>	Protetto contro getti d'acqua <i>Water jet proof</i>
<b>6</b>	Totalmente protetto contro la polvere <i>Fully dust proof</i>	<b>6</b>	Protetto dalle ondate <i>Wave proof</i>
<b>7</b>	N.A.	<b>7</b>	Protetto contro immersione <i>Watertight immersion fixture.</i>
<b>8</b>	N.A.	<b>8</b>	Protetto contro immersione/sommersione prolungata <i>Watertight immersion fixture for a long time.</i>

**Classe di isolamento termico**

**Insulation class**

Classe / Class	$\Delta t$ °C Temp. ambiente: 40°C Ambient temperature: 40°C
<b>A</b>	65°C
<b>B</b>	90°C
<b>F</b>	115°C
<b>H</b>	140°C

**Tipi di servizio IEC**

**IEC duty cycle ratings**

<b>S1</b>	<b>Servizio continuo.</b> Funzionamento a carico costante per una durata sufficiente al raggiungimento dell'equilibrio termico.	<b>Continuous duty.</b> The motor works at a constant load for enough time to reach temperature equilibrium
<b>S2</b>	<b>Servizio di durata limitata.</b> Funzionamento a carico costante per una durata inferiore a quella necessaria al raggiungimento dell'equilibrio termico, seguito da un periodo di riposo tale da riportare il motore alla temperatura ambiente.	<b>Short time duty.</b> The motor works at a constant load, but not long enough to reach temperature equilibrium, and the rest periods are long enough for the motor to reach ambient temperature.
<b>S3</b>	<b>Servizio periodico intermittente.</b> Sequenze di cicli identici di marcia e di riposo a carico costante, senza raggiungimento dell'equilibrio termico. La corrente di spunto ha effetti trascurabili sul surriscaldamento del motore.	<b>Intermittent periodic duty.</b> Sequential, identical run and rest cycles with constant load. Temperature equilibrium is never reached. Starting current has little effect on temperature rise.
<b>S4</b>	<b>Servizio periodico intermittente con avviamento.</b> Sequenza di cicli di funzionamento identici di avviamento, marcia e riposo a carico costante, senza raggiungimento dell'equilibrio termico. La corrente di spunto ha effetti sul riscaldamento del motore.	<b>Intermittent periodic duty with starting.</b> Sequential identical start, run and rest cycles with constant load. Temperature equilibrium is not reached, but starting current affects temperature rise.
<b>S5</b>	<b>Servizio periodico intermittente con frenatura elettrica.</b> Sequenza di cicli di funzionamento identici di avviamento, marcia a carico costante, frenatura elettrica e riposo, senza raggiungimento dell'equilibrio termico.	<b>Intermittent periodic duty with electric braking.</b> Sequential, identical cycles of starting, running at constant load, electric braking and rest. Temperature equilibrium is not reached.
<b>S6</b>	<b>Servizio periodico ininterrotto con carico intermittente.</b> Sequenza di cicli di lavoro identici con carico costante e senza carico. Non ci sono periodi di riposo.	<b>Continuous operation with intermittent load.</b> Sequential, identical cycles of running with constant load and running with no load. No rest periods.
<b>S7</b>	<b>Servizio periodico ininterrotto con frenatura elettrica.</b> Sequenza di cicli di funzionamento identici di avviamento, marcia a carico costante e frenatura elettrica, senza periodi di riposo.	<b>Continuous operation with electric braking.</b> Sequential, identical cycles of starting, running at constant load and electric braking. No rest periods.
<b>S8</b>	<b>Servizio periodico ininterrotto con variazioni di carico e di velocità.</b> Sequenza di cicli identici di avviamento, marcia a carico costante e velocità definita, seguiti da marcia a carico costante differente e velocità differente dalla precedente. Non ci sono periodi di riposo.	<b>Continuous operation with periodic changes in load and speed.</b> Sequential, identical, duty cycles of start, run at constant load and given speed, then run at other constant loads and speeds. No rest periods.

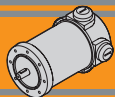

**ND120.120 - ND120.240**

**Caratteristiche**

**Features**

Costruzione	Tubolare, senza ventilazione
Grandezza	Ø 65 mm
Potenza	160 W S2 (120 W S1)
Magneti	4 magneti in terre rare
Supporti	Cuscinetti a sfera
Fori di montaggio	8
Alimentazione	Bassa tensione, 12 o 24 Vcc
Spazzole	N° 4 di composto grafite-rame
Cavo di alimentazione	Lunghezza: 1000 mm
Bisporgenza	Standard

Construction	Tubular, without fan
Size	Ø 65 mm
Power	160 W S2 (120 W S1)
Magnets	4 rare earth magnets
Bearings	Ball bearings
Mounting holes	8
Power supply	Low voltage, 12 or 24 Vdc
Brushes	4 brushes made of graphite/copper composite
Electric cable	Length: 1000 mm
Rear Shaft	Standard

Tipo Type	S	Pn [W]	V [V]	I [A]	IC	FF	Mn [Nm]	n <sub>1</sub> [min <sup>-1</sup> ]	IP	Kg
ND120.120	S1	120	12	13.9	F	1	0.38	3000	20	1.6
	S2 20'	160		19			0.51			
ND120.240	S1	120	24	6.9			0.38			
	S2 20'	160		9.0			0.51			

**Dimensioni**

**Dimensions**

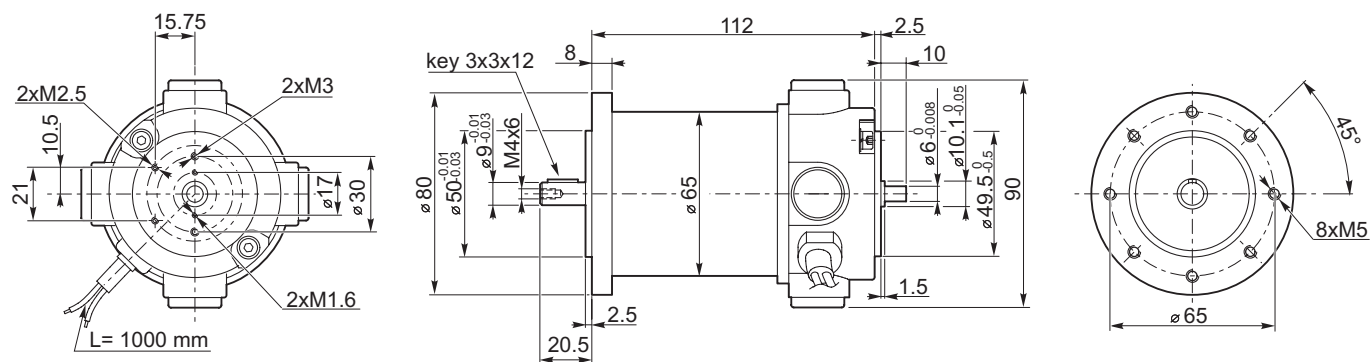

Freno / Brake → B9

Encoder → B9

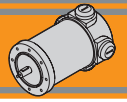

**ND120.120 - ND120.240**

Prestazioni

Performances

**ND120.120**

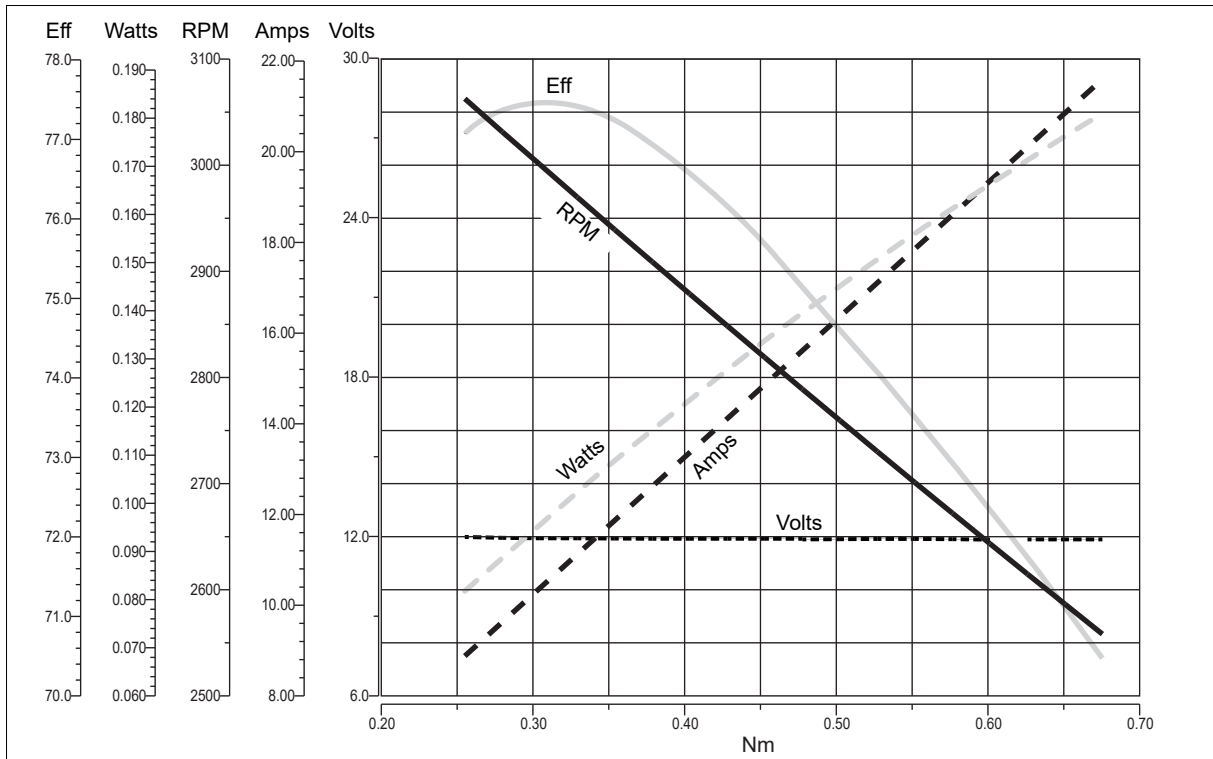

**ND120.240**

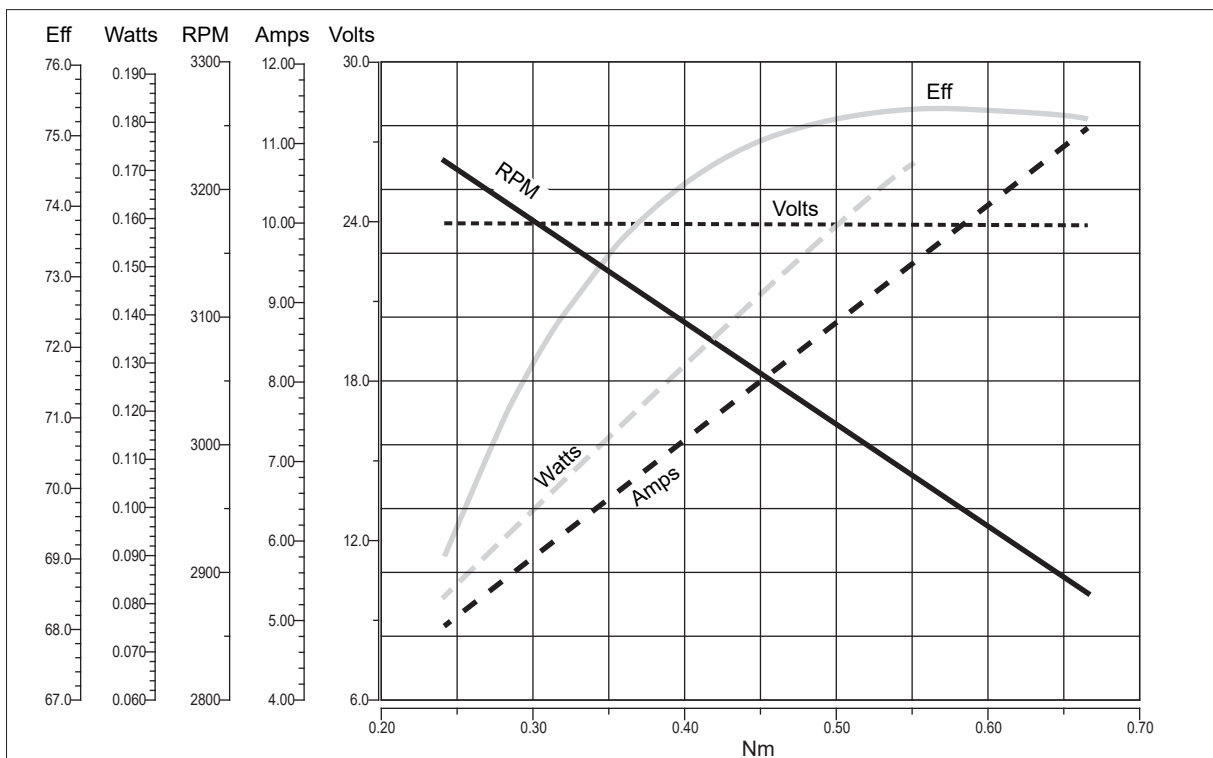

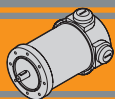

**ND180.120 - ND180.240**

**Caratteristiche**

**Features**

Costruzione	Tubolare, senza ventilazione
Grandezza	Ø 65 mm
Potenza	250 W S2 (180 W S1)
Magneti	4 magneti in terre rare
Supporti	Cuscinetti a sfera
Fori di montaggio	8
Alimentazione	Bassa tensione, 12 o 24 Vcc
Spazzole	N° 4 di composto grafite-rame
Cavo di alimentazione	Lunghezza: 1000 mm
Bisporgenza	Standard

Construction	Tubular, without fan
Size	Ø 65 mm
Power	250 W S2 (180 W S1)
Magnets	4 rare earth magnets
Bearings	Ball bearings
Mounting holes	8
Power supply	Low voltage, 12 or 24 Vdc
Brushes	4 brushes made of graphite/copper composite
Electric cable	Length: 1000 mm
Rear Shaft	Standard

Tipo Type	S	Pn [W]	V [V]	I [A]	IC	FF	Mn [Nm]	n <sub>1</sub> [min <sup>-1</sup> ]	IP	Kg
ND180.120	S1	180	12	20	F	1	0.57	3000	20	1.95
	S2 20'	250		30			0.80			
ND180.240	S1	180	24	10						
	S2 20'	250		14			0.57			
							0.80			

**Dimensioni**

**Dimensions**

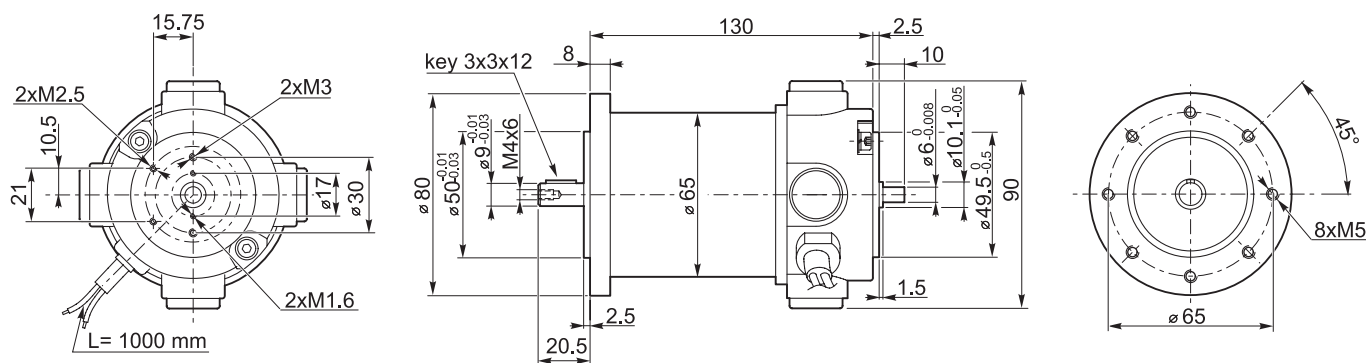

Freno / Brake → B9

Encoder → B9

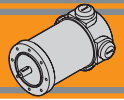

**ND180.120 - ND180.240**

Prestazioni

Performances

**ND180.120**

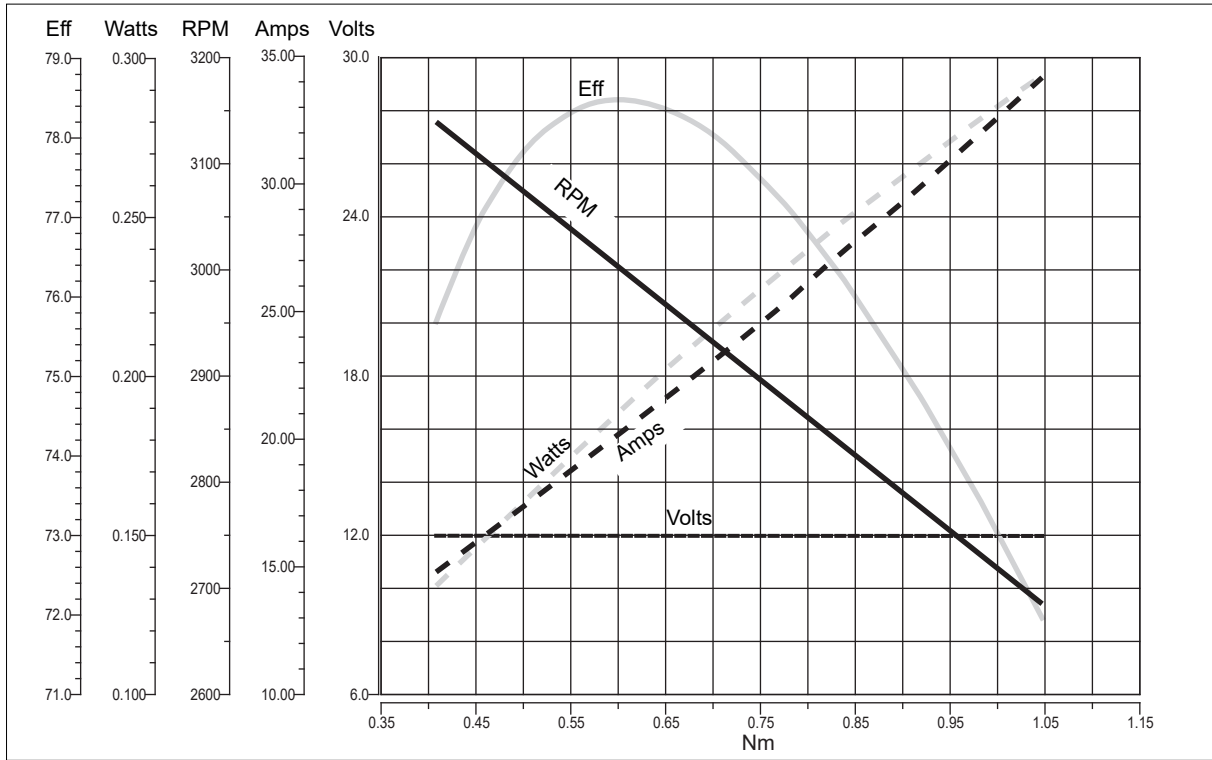

**ND180.240**

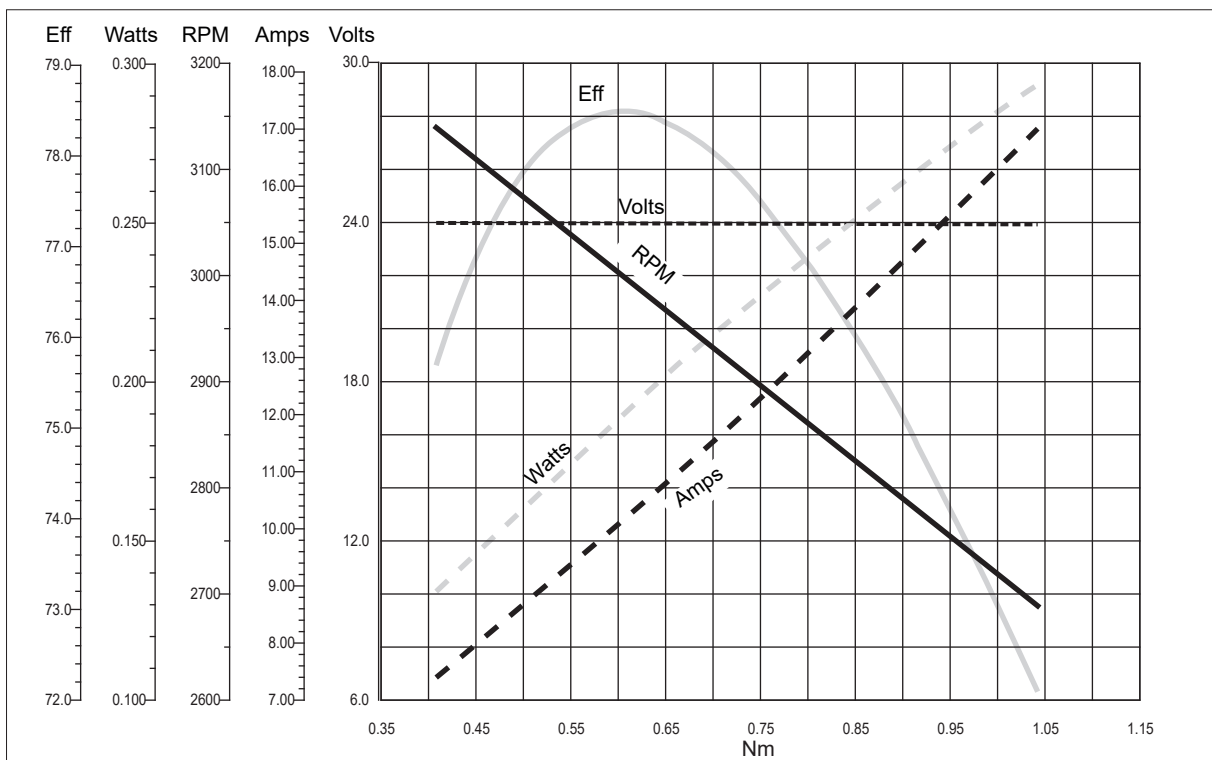

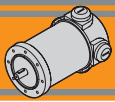

**Legenda / Glossario dei grafici**

**Key / Diagram Glossary**

Dato un motore in CC, la velocità di rotazione è funzione lineare della coppia; così pure la corrente assorbita è una funzione lineare della coppia. Velocità e corrente variano in maniera sensibile al variare del carico.

With a DC motor, the rotational speed is a linear function of the torque. In the same way, the absorbed current is also a linear function of the torque. Speed and current change a lot against applied torque.

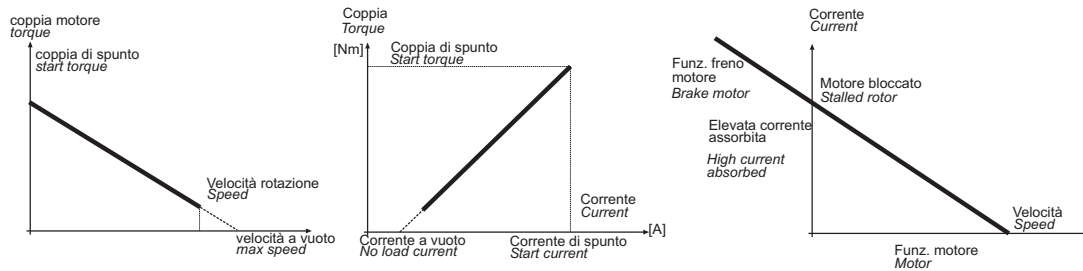

La potenza utile (potenza all'albero) si ricava dalla formula:

$$P_n [W] = M_n \cdot S = \frac{2\pi}{60} \cdot n_1 \cdot M_n$$

The output power is calculated using the formula:

$$P_n [W] = M_n \cdot S = \frac{2\pi}{60} \cdot n_1 \cdot M_n$$

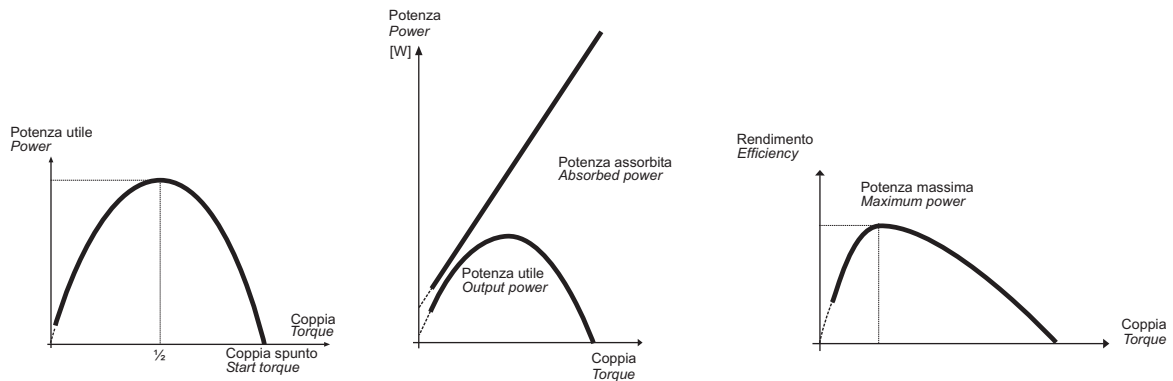

Poiché la tensione di alimentazione è costante mentre la corrente è linearmente crescente al crescere della coppia, l'andamento della potenza assorbita è una retta crescente. Dal rapporto tra la potenza meccanica e la potenza assorbita si ottiene il grafico dell'efficienza.

Since the supply voltage is constant, whereas the current increases in a linear manner as the torque increases, the absorbed power trend is a straight line going up. Efficiency is shown from the ratio between the output power and the absorbed power.

**Formule utili**

**Useful formulas**

$$\eta = \frac{P_n}{P_a}$$

$$P_a = V \cdot I$$

$$P_n = V \cdot I \cdot \eta$$

$$P_n = M_n \cdot S_v$$

$$S_v = \frac{n_1}{9.55}$$

$$\eta = \frac{P_n}{P_a}$$

$$P_a = V \cdot I$$

$$P_n = V \cdot I \cdot \eta$$

$$P_n = M_n \cdot S_v$$

$$S_v = \frac{n_1}{9.55}$$

$$[HP] \cdot 746 = [W]$$

Esempio 2 HP = circa 1500 W.

$$[HP] \cdot 746 = [W]$$

Example 2 HP = approx. 1500 W.

<b>S</b>	—	Servizio	<i>Duty</i>
<b>P<sub>n</sub></b>	[W]	Potenza in uscita	<i>Rated power</i>
<b>P<sub>a</sub></b>	[W]	Potenza assorbita	<i>Absorbed power</i>
<b>M<sub>n</sub></b>	[Nm]	Coppia nominale	<i>Rated torque</i>
<b>V</b>	[V]	Tensione	<i>Voltage</i>
<b>I</b>	[A]	Corrente assorbita	<i>Absorbed current</i>
<b>n<sub>1</sub></b>	[min <sup>-1</sup> ]	Numero giri motore	<i>Motor speed</i>
<b>S<sub>v</sub></b>	[rad/s]	Velocità angolare	<i>Angular speed</i>
<b>IC</b>	—	Classe d'isolamento termico	<i>Thermal insulation class</i>
<b>FF</b>	—	Fattore di forma	<i>Form factor</i>
<b>IP</b>	—	Classe di protezione	<i>Protection class</i>
<b>η</b>	—	Rendimento	<i>Efficiency</i>
<b>Kg</b>	—	Peso	<i>Weight</i>

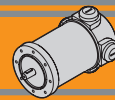

Freno

Brake

ND...BR Freno / Brake

ND...BRL Freno con leva di sblocco/ Brake with hand release

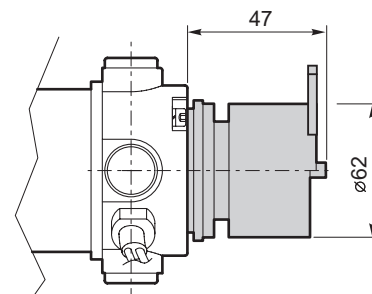
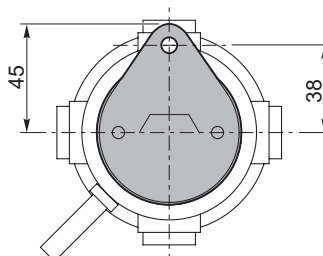
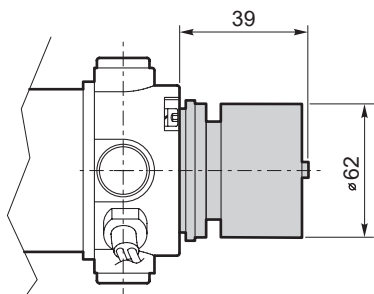

	Pn [W]	V [V]	Mn [Nm]	n <sub>1</sub> [min <sup>-1</sup> ]
Caratteristiche del freno / Break features	14	12	1.8	3000
		24		

Encoder

Encoder

ND...ME22

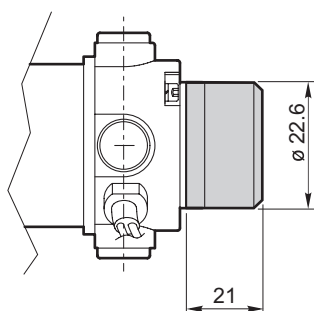

Nota: Fornito con cavo lungo 300 mm

Note: Supplie with cavle 300 mm long

Risoluzione Encoder (CPR) / Encoder Resolution (CPR)	Numero di canali / Number of channels	Tensione d'alimentazione / Power supply
001	2	5 VdC - TTL
100		
300		

Per risoluzioni encoder non standard, si prega di contattare il nostro Servizio Tecnico.

For non-standard encoder resolution, please contact our Technical Department.





Neodymium

## Motoriduttori CC ad ingranaggi cilindrici DC helical in-line gearmotors





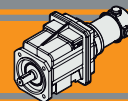

<b>Indice</b>	<b>Index</b>	Pag. Page
Caratteristiche tecniche	<i>Technical features</i>	<b>C2</b>
Designazione	<i>Classification</i>	<b>C3</b>
Sensi di rotazione	<i>Direction of rotation</i>	<b>C3</b>
Lubrificazione	<i>Lubrication</i>	<b>C3</b>
Simbologia	<i>Symbols</i>	<b>C4</b>
Carichi radiali	<i>Radial loads</i>	<b>C4</b>
Dati tecnici per servizio S2	<i>Technical data for S2 duty</i>	<b>C5</b>
Motori applicabili	<i>IEC Motor adapters</i>	<b>C6</b>
Dimensioni	<i>Dimensions</i>	<b>C7</b>

Questa sezione annulla e sostituisce ogni precedente edizione o revisione. Qualora questa sezione non Vi sia giunta in distribuzione controllata, l'aggiornamento dei dati ivi contenuto non è assicurato. **In tal caso la versione più aggiornata è disponibile sul nostro sito internet [www.transtecno.com](http://www.transtecno.com)**

*This section replaces any previous edition and revision. If you obtained this catalogue other than through controlled distribution channels, the most up to date content is not guaranteed. In this case the latest version is available on our web site [www.transtecno.com](http://www.transtecno.com)*

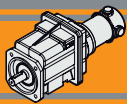

### Caratteristiche tecniche

Le caratteristiche principali dei motoriduttori CC ad ingranaggi cilindrici a magneti permanenti in neodimio NDCMG sono:

- Alimentazione in bassa tensione 12/24 Vcc
- Possibilità di montaggio encoder
- Potenze motore disponibili da 160 a 250W S2
- Magneti in Neodimio
- Carcasse dei riduttori in pressofusione di alluminio
- Lubrificazione permanente con olio sintetico
- Ingranaggi sempre rettificati

### Technical features

The main features of NDCMG neodymium permanent magnets DC helical in-line gearmotors range are:

- Low voltage power supply 12/24 Vdc
- Suitable for encoder assembly
- Motor power ratings available from 160 to 250W S2
- Neodymium magnets
- Die-cast aluminum housing
- Permanent synthetic oil long-life lubrication
- Ground helical gears

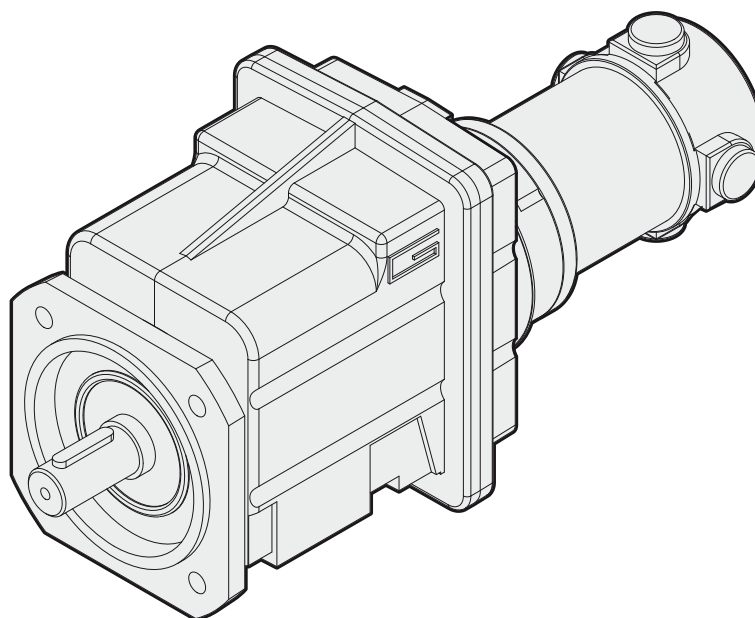

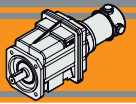

**Designazione**

**Classification**

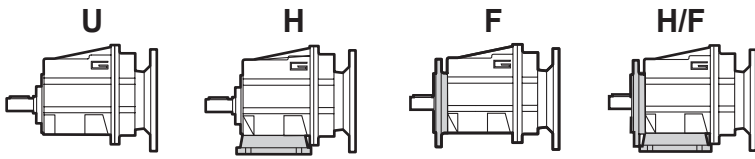

MOTORIDUTTORE / GEARMOTOR						
NDCMG	120/002		U	8.99	D20	240
Tipo Type	Grandezza Size		Versione Version	Rapporto Ratio	Albero uscita Output shaft	Versione motore Motor version
NDCMG 	120/002	180/002	U...	vedi tabelle see tables	vedi tabelle see tables	120
	120/012	180/012	H...			240
	120/013	180/013	F...			
	120/022	180/022	H.../F...			
	120/023	180/023				
	120/033	180/033				
	120/043	180/043				

**Sensi di rotazione**

**Direction of rotation**

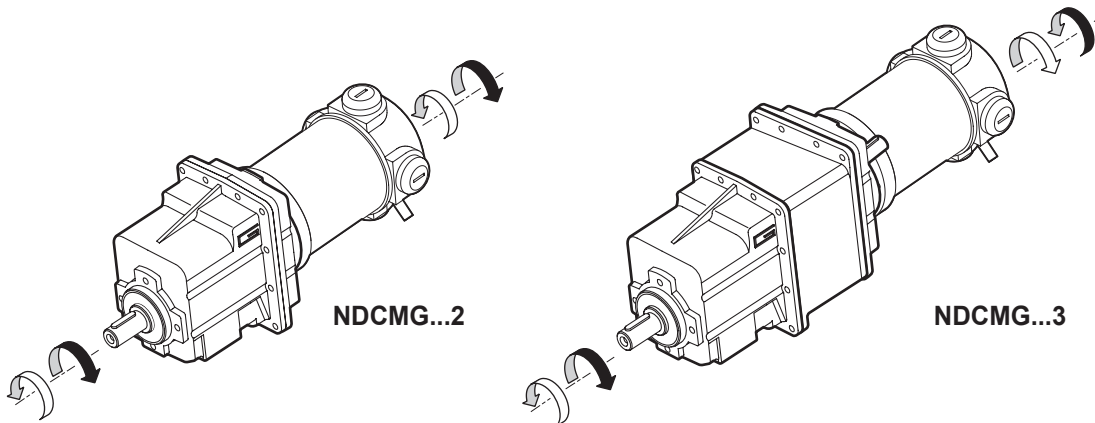

**Lubrificazione**

**Lubrication**

Tutti i riduttori nelle taglie 002 sono forniti completi di lubrificante sintetico viscosità 320, pertanto possono essere installati in qualunque posizione di montaggio e non necessitano di manutenzione.

*Permanent synthetic oil long-life lubrication ( viscosity grade 320) makes it possible to use sizes 002 in all mounting positions; for this reason they can be installed in any assembly position and do not require maintenance.*

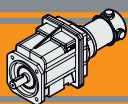

### Simbologia

### Symbols

$n_1$	[min <sup>-1</sup> ]	Velocità in ingresso / <i>Input speed</i>
$n_2$	[min <sup>-1</sup> ]	Velocità in uscita / <i>Output speed</i>
$i$		Rapporto di riduzione / <i>Ratio</i>
$P_1$	[kW]	Potenza in entrata / <i>Input power</i>
$M_2$	[Nm]	Coppia nominale in uscita in funzione di $P_1$ / <i>Output torque referred to <math>P_1</math></i>
$sf$		Fattore di servizio / <i>Service factor</i>
$R_2$	[N]	Carico radiale ammissibile in uscita / <i>Permitted output radial load</i>
$A_2$	[N]	Carico assiale ammissibile in uscita / <i>Permitted output axial load</i>

### Carichi radiali

### Radial loads

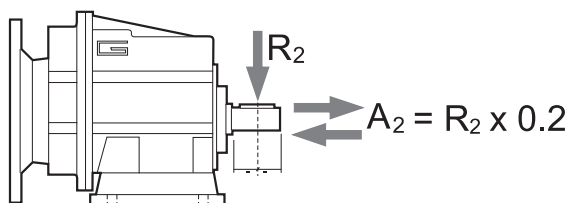

$n_2$ [min <sup>-1</sup> ]	$R_2$ [N]				
	CMG 00	CMG 01	CMG 02	CMG 03	CMG 04
700	416	764	1529	1987	2379
600	437	805	1609	2092	2504
500	465	855	1710	2223	2661
400	501	921	1842	2395	2866
250	586	1077	2154	2801	3353
180	653	1323	2554	3321	3897
150	748	1406	2714	3529	4244
120	806	1631	3467	3801	4572
100	958	1842	3684	4507	5234
80	1032	1984	3969	5042	5991
60	1136	2184	4368	5549	6594
40	1300	2500	5000	6500	8000
10	1300	2500	5000	6500	8000

Quando il carico radiale risultante non è applicato sulla mezzeria dell'albero occorre calcolare quello effettivo con la seguente formula:

When the resulting radial load is not applied on the centre line of the shaft it is necessary to calculate the effective load with the following formula:

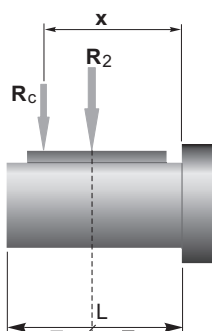

	CMG 00	CMG 01	CMG 02	CMG 03	CMG 04
<b>a</b>	73	104	117	132	150
<b>b</b>	53	84	92	102	115
<b><math>R_{2MAX}</math></b>	1300	2500	5000	6500	8000

$$R_c = \frac{R_2 \cdot a}{(b+x)} \leq R_{2MAX}$$

$a, b$  = valori riportati nella tabella  
 $a, b$  = values given in the table

$$R \leq R_c$$

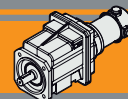

**Dati tecnici per servizio S2**

**Technical data for S2 duty**

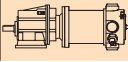
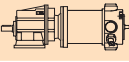
$P_1$ [W]	$n_2$ [min <sup>-1</sup> ]	$M_2$ [Nm]	sf	i		Versione motore Motor version	$P_1$ [W]	$n_2$ [min <sup>-1</sup> ]	$M_2$ [Nm]	sf	i		Versione motore Motor version				
<b>160</b>							<b>250</b>										
(3000 min <sup>-1</sup> )	<b>596</b>	2.5	12.6	5.03	<b>120/002</b>	120/240	(3000 min <sup>-1</sup> )	<b>596</b>	3.8	8.1	5.03	<b>180/002</b>	120/240				
	<b>492</b>	3.0	10.4	6.10						<b>492</b>	4.7			6.7	6.10		
	<b>401</b>	3.7	8.5	7.49						<b>401</b>	5.7			5.4	7.49		
	<b>334</b>	4.4	8.9	8.99						<b>334</b>	6.9			5.7	8.99		
	<b>295</b>	5.0	7.9	10.16						<b>295</b>	7.8			5.0	10.16		
	<b>249</b>	5.9	6.6	12.07						<b>249</b>	9.2			4.2	12.07		
	<b>224</b>	6.6	8.4	13.40						<b>224</b>	10			5.4	13.40		
	<b>198</b>	7.4	7.4	15.14						<b>198</b>	12			4.8	15.14		
	<b>165</b>	8.9	6.2	18.17						<b>165</b>	14			4.0	18.17		
	<b>139</b>	11	5.2	21.58						<b>139</b>	17			3.3	21.58		
	<b>128</b>	12	4.8	23.51						<b>128</b>	18			3.1	23.51		
	<b>120</b>	12	4.5	25.10						<b>120</b>	19			2.9	25.10		
	<b>111</b>	13	4.2	27.08						<b>111</b>	21			2.7	27.08		
	<b>92</b>	16	3.5	32.49						<b>92</b>	25			2.2	32.49		
	<b>71</b>	21	2.7	42.04						<b>71</b>	32			1.7	42.04		
	<b>67</b>	22	2.5	44.89						<b>67</b>	34			1.6	44.89		
	<b>61</b>	24	2.3	48.86						<b>61</b>	37			1.5	48.86		
	<b>54</b>	27	2.0	55.10													
	<b>85</b>	17	5.4	35.47			<b>120/012</b>	120/240		<b>127</b>	18			5.2	23.56	<b>180/012</b>	120/240
	<b>65</b>	22	4.2	45.89					<b>101</b>	23	4.2	29.56					
	<b>61</b>	24	3.9	49.00					<b>85</b>	27	3.5	35.47					
	<b>56</b>	26	3.6	53.33					<b>65</b>	35	2.7	45.89					
	<b>50</b>	29	3.2	60.15					<b>61</b>	37	2.5	49.00					
	<b>47</b>	30	3.1	63.22	<b>120/013</b>	120/240		<b>56</b>	41	2.3	53.33						
	<b>40</b>	36	2.6	75.08					<b>50</b>	46	2.0	60.15					
	<b>34</b>	43	2.2	89.17					<b>47</b>	47	2.0	63.22	<b>180/013</b>	120/240			
	<b>27</b>	54	1.7	113.05					<b>40</b>	56	1.7	75.08					
	<b>22</b>	64	1.5	134.27					<b>34</b>	67	1.4	89.17					
	<b>17</b>	83	1.1	173.72					<b>27</b>	85	1.1	113.05					
	<b>15</b>	97	1.0	202.16					<b>22</b>	100	0.9	134.27					
	<b>11</b>	125	0.8	261.57					<b>17</b>	130	0.7	173.72					
	<b>10</b>	134	0.7	304.00					<b>15</b>	134	0.7	202.16					
	<b>7.6</b>	134	0.7	393.33					<b>11</b>	134	0.7	261.57					
	<b>6.8</b>	134	0.7	443.59			<b>10</b>	134	0.7	304.00							
							<b>7.6</b>	134	0.7	393.33							
							<b>6.8</b>	134	0.7	443.59							
	<b>33</b>	43	3.6	90.29	<b>120/023</b>	120/240		<b>65</b>	35	4.4	46.46	<b>180/022</b>	120/240				
	<b>26</b>	55	2.8	114.46					<b>60</b>	38	4.1			49.61			
	<b>22</b>	65	2.4	135.95					<b>56</b>	41	3.8			54.00			
	<b>17</b>	84	1.9	175.89					<b>49</b>	47	3.4			60.90			
	<b>15</b>	98	1.6	204.69													
	<b>11</b>	127	1.2	264.84													
	<b>10</b>	147	1.1	307.80													
	<b>7.5</b>	191	0.8	398.25													
	<b>6.7</b>	215	0.7	449.14													
	<b>17</b>	83	2.8	174.26	<b>120/033</b>	120/240											
	<b>13</b>	108	2.2	225.47													
	<b>11</b>	125	1.9	262.05													
	<b>9.2</b>	156	1.5	325.79													
	<b>7.9</b>	181	1.3	378.64													
	<b>7.0</b>	204	1.1	427.03													
	<b>11</b>	125	3.1	262.05	<b>120/043</b>	120/240											
	<b>9.2</b>	156	2.5	325.79													
	<b>7.9</b>	181	2.2	378.64													
	<b>7.0</b>	204	1.9	427.03													

**NDCMG**

N.B.  
Verificare sempre che la coppia M2 utilizzata non ecceda il valore indicato nelle caselle in grigio  
N.B.  
*Please check that the output torque M2 does not exceed the value in the grey areas*

**NOTA:** per servizio continuo o altamente intermittente, contattare il servizio tecnico  
**NOTE:** for continuous or highly intermittent duty, please contact our technical service

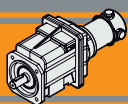

### Dati tecnici per servizio S2

### Technical data for S2 duty

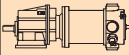
$P_1$ [W]	$n_2$ [min <sup>-1</sup> ]	$M_2$ [Nm]	sf	i		Versione motore Motor version
<b>250</b>						
(3000 min <sup>-1</sup> )	<b>47</b>	48	3.3	64.01	<b>180/023</b>	120/240
	<b>39</b>	57	2.7	76.02		
	<b>33</b>	68	2.3	90.29		
	<b>26</b>	86	1.8	114.46		
	<b>22</b>	102	1.5	135.95		
	<b>17</b>	132	1.2	175.89		
	<b>15</b>	153	1.0	204.69		
	<b>11</b>	198	0.8	264.84		
	<b>10</b>	223	0.7	307.80		
	<b>7.5</b>	223	0.7	398.25		
	<b>6.7</b>	223	0.7	449.14		

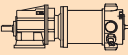
$P_1$ [W]	$n_2$ [min <sup>-1</sup> ]	$M_2$ [Nm]	sf	i		Versione motore Motor version
<b>250</b>						
(3000 min <sup>-1</sup> )	<b>41</b>	54	4.3	72.83	<b>180/033</b>	120/240
	<b>31</b>	73	3.2	97.45		
	<b>26</b>	87	2.7	115.74		
	<b>21</b>	105	2.2	140.81		
	<b>17</b>	130	1.8	174.26		
	<b>13</b>	169	1.4	225.47		
	<b>11</b>	196	1.2	262.05		
	<b>9.2</b>	244	1.0	325.79		
	<b>7.9</b>	283	0.8	378.64		
	<b>7.0</b>	319	0.7	427.03		
	<b>21</b>	105	3.7	140.81	<b>180/043</b>	120/240
	<b>17</b>	130	3.0	174.26		
	<b>13</b>	169	2.3	225.47		
	<b>11</b>	196	2.0	262.05		
	<b>9.2</b>	244	1.6	325.79		
	<b>7.9</b>	283	1.4	378.64		
	<b>7.0</b>	319	1.2	427.03		

N.B.  
Verificare sempre che la coppia  $M_2$  utilizzata non ecceda il valore indicato nelle caselle in grigio  
N.B.  
Please check that the output torque  $M_2$  does not exceed the value in the grey areas

**NOTA:** per servizio continuo o altamente intermittente, contattare il servizio tecnico

**NOTE:** for continuous or highly intermittent duty, please contact our technical service

### Motori applicabili

### IEC Motor adapters

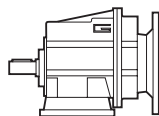
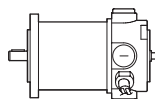

		ND	
		120.120 120.240	180.120 180.240
<b>CMG</b>	<b>002</b>	5.03 - 55.10	
	<b>012</b>	3.82 - 60.15	
	<b>013</b>	63.22 - 443.59	
	<b>022</b>	3.66 - 60.9	
	<b>023</b>	64.01 - 449.14	
	<b>033</b>	72.83 - 427.03	
	<b>043</b>	72.83 - 427.03	

5.03 - 55.10

Rapporti di riduzione  $i$   
Ratio  $i$

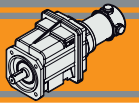

**Dimensioni**

**Dimensions**

**NDCMG..U**

**NDCMG120/002 U**  
**NDCMG180/002 U**

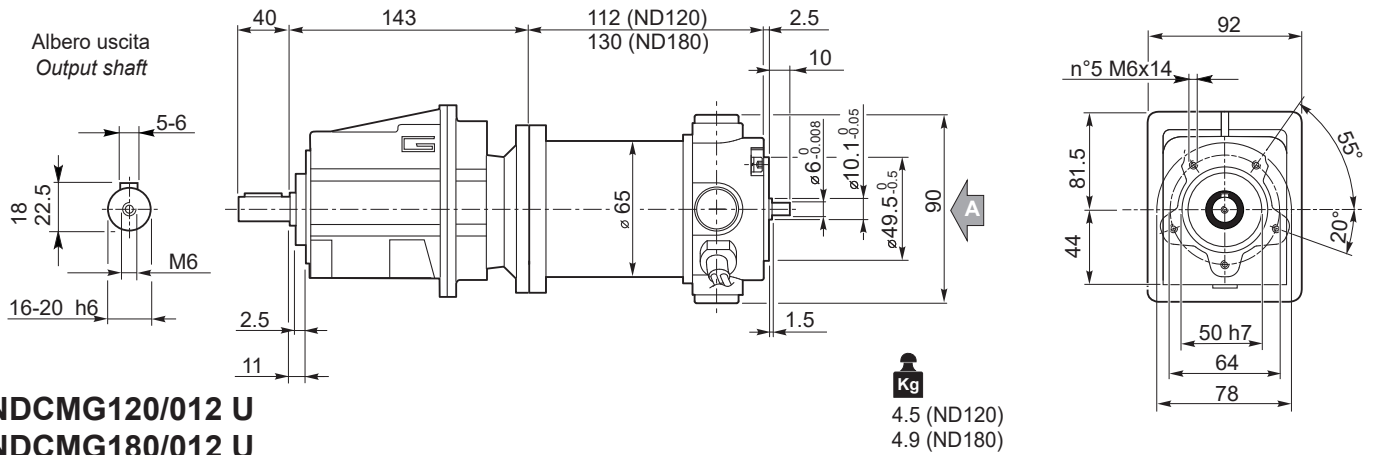

**NDCMG120/012 U**  
**NDCMG180/012 U**

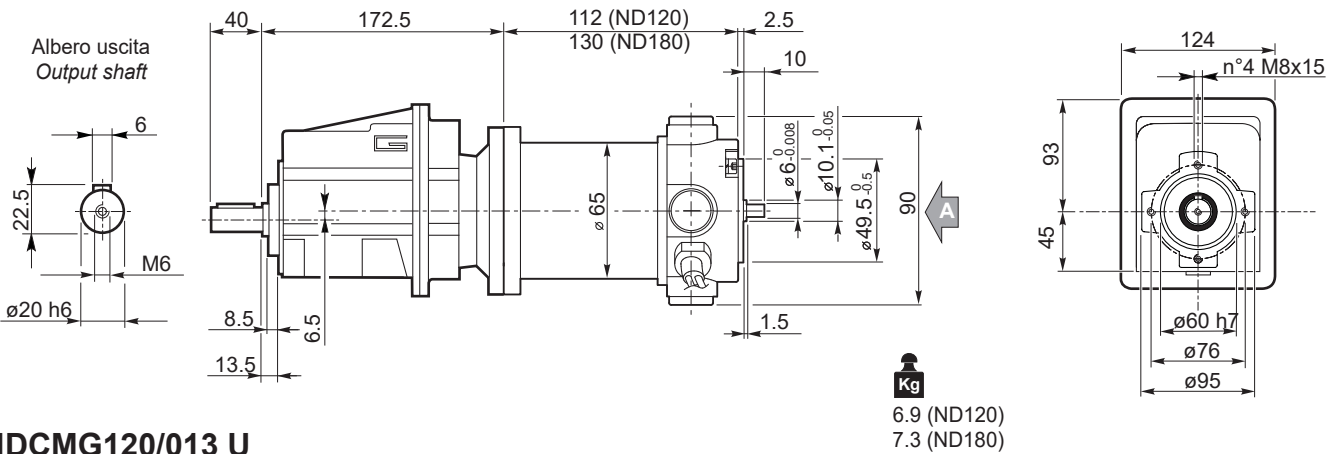

**NDCMG120/013 U**  
**NDCMG180/013 U**

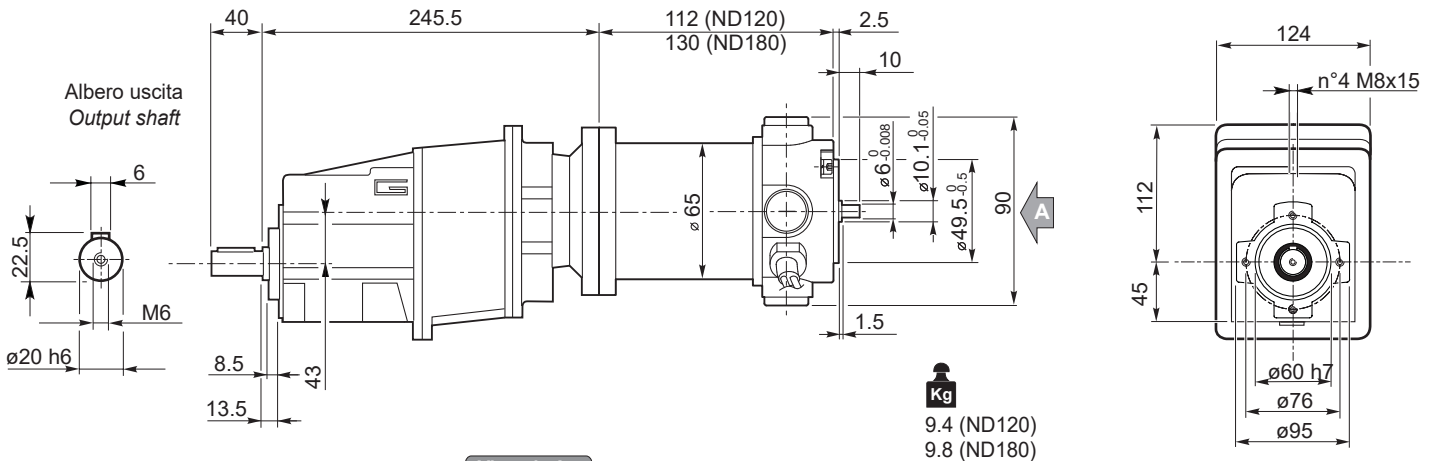

Vista da A  
View from A

**NDCMG...H**



**NDCMG...F**



**NDCMG...H/F**

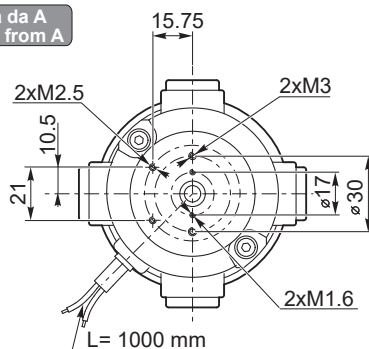

**Freno / Brake**



**Encoder**



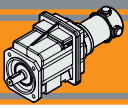

### Dimensioni

### Dimensions

## NDCMG..U

### NDCMG120/022 U NDCMG180/022 U

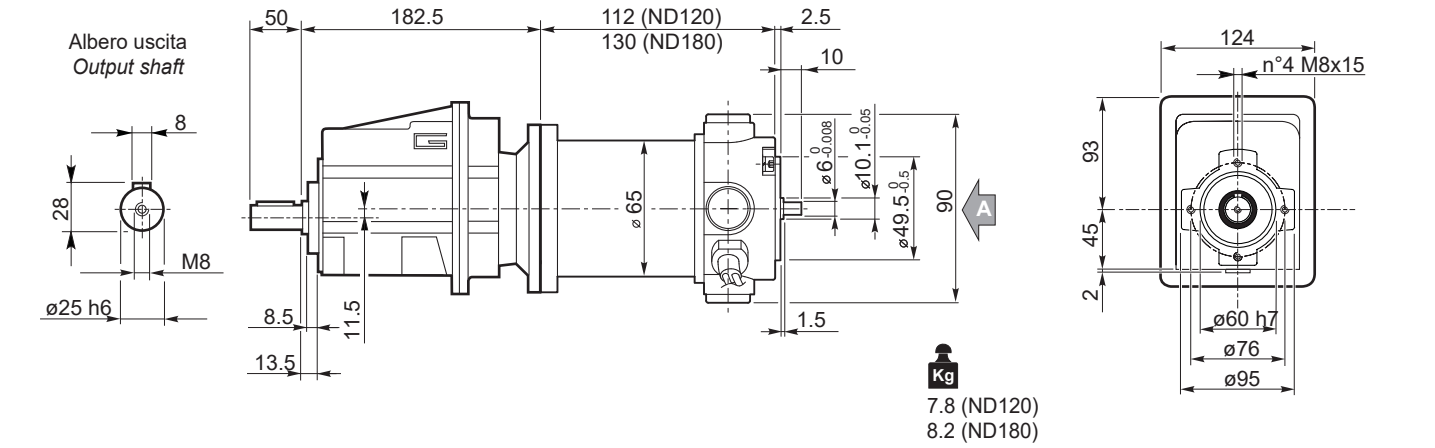

### NDCMG120/023U NDCMG180/023 U

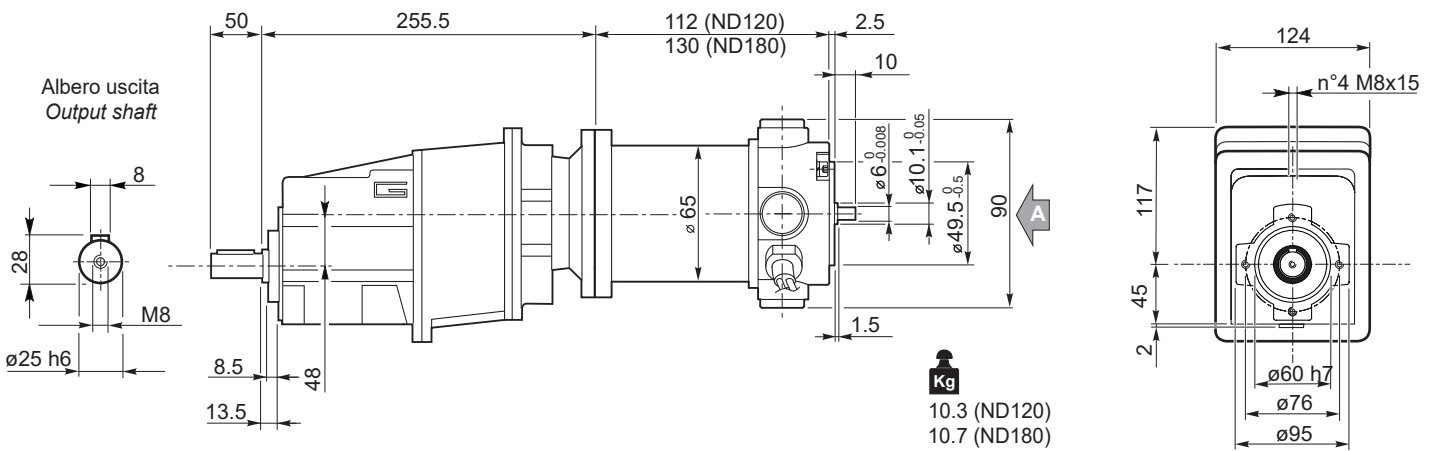

Vista da A  
View from A

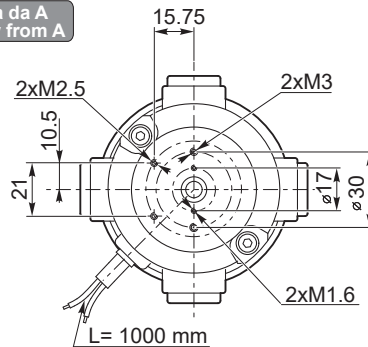

NDCMG...H → C10

NDCMG...F → C11

NDCMG...H/F → C12

Freno / Brake → B9

Encoder → B9

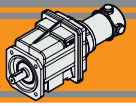

**Dimensioni**

**Dimensions**

**NDCMG..U**

**NDCMG120/033 U**  
**NDCMG180/033 U**

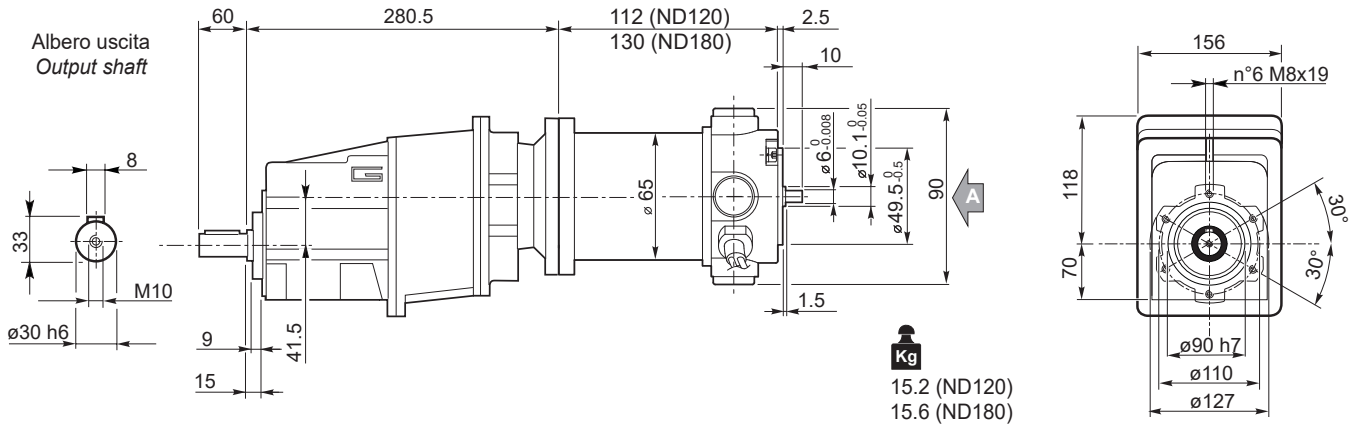

**NDCMG120/043 U**  
**NDCMG180/043 U**

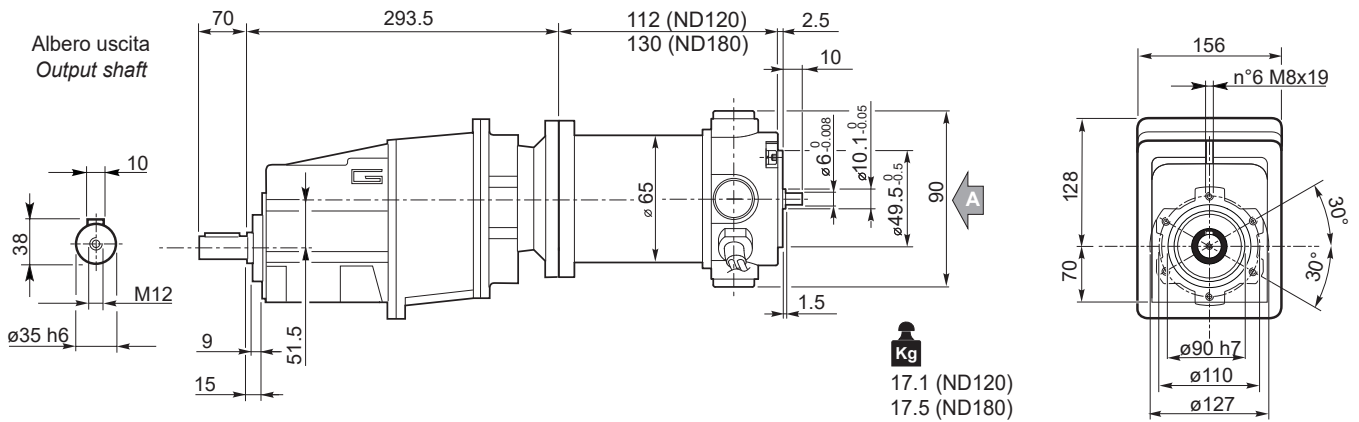

**NDCMG...H**



**NDCMG...F**



**NDCMG...H/F**



Vista da A  
View from A

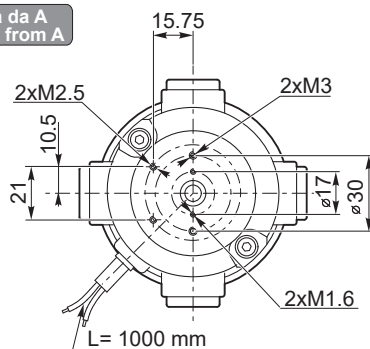

**Freno / Brake**



**Encoder**



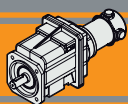

### NDCMG..H

#### NDCMG..2 H..

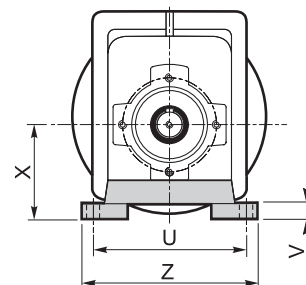
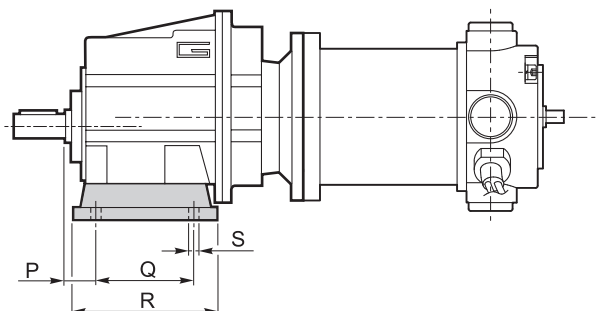

#### NDCMG..3 H..

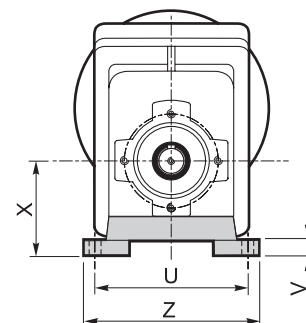
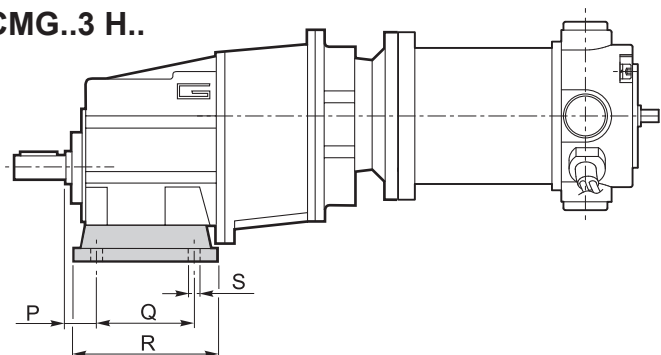

Versione H / H Version

CMG	P	Q	R	S	U	V	X	Z	Piede / Foot	
									Tipo / Type	Peso / Weight [kg]
002	18	60	80	9	100	10	60	120	H60	0.2
	18	80	104	9	110 - 120	10	75	145	H75	0.3
	18	50 - 87	110	9	110	10	85	135	H85	0.4
012 013	20	85	108	9	115	12	65	139	H65	0.7
	18	80	118	9	110	12	75	140	H75	1.0
	25	85	120	9	120	12	80	140	H80	1.1
	18	50 - 87	118	9	110	12	85	130	H85	1.2
	25	130	154	9	110	12	90	135	H90	1.5
022 023	18	60 - 107.5	135	11	130	12	100	155	H100	1.7
	20	85	108	9	115	12	65	139	H65	0.7
	18	80	118	9	110	12	75	140	H75	1.0
	25	85	120	9	120	12	80	140	H80	1.1
	18	50 - 87	118	9	110	12	85	130	H85	1.2
	25	130	154	9	110	12	90	135	H90	1.5
033	18	60 - 107.5	135	11	130	12	100	155	H100	1.7
	30	105	136	14	160	14	95	194	H95	1.5
	30	100	150	11	150	14	110	185	H110	1.9
	18	70			160					
	30	165	195	14	135	14	115	170	H115	2.2
35	110	160	14	170	14	120	210	H120	2.6	
043	30	105	136	14	160	14	95	194	H95	1.5
	30	100	150	11	150	14	110	185	H110	1.9
	18	70			160					
	30	165	195	14	135	14	115	170	H115	2.2
	35	110	160	14	170	14	120	210	H120	2.6

Preferenziale / Preferred

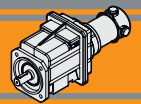

**Dimensioni**

**Dimensions**

**NDCMG..F**

**NDCMG..2 F..**

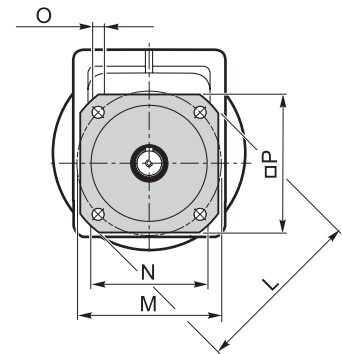
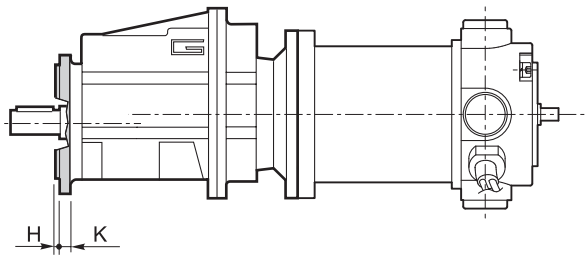

**NDCMG..3 F..**

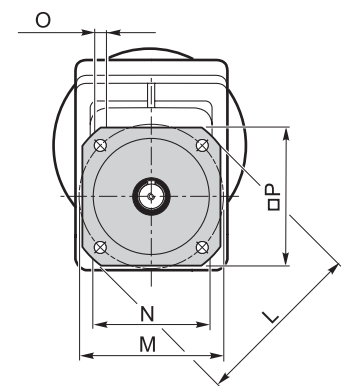
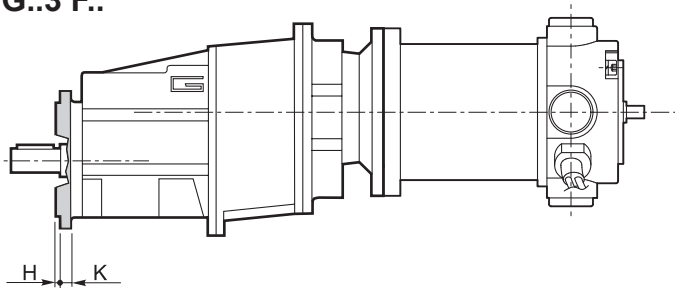

NDCMG

Versione F / F Version

CMG	H	K	L	M	N f7	O	P	Flangia / Flange	
								Tipo / Type	Peso / Weight [kg]
002	3.5	7	105	85	70	6.5	90	F105	0.1
	3.5	8	120	100	80	7	100	F120	0.2
	3.5	8	140	115	95	9	115	F140	0.2
012 013	3	9	120	100	80	9	106	F120	0.5
	3.5	9	140	115	95	9	115	F140	0.8
	3.5	9	160	130	110	9	126	F160	1.1
	3.5	11	200	165	130	11	165	F200	1.8
022 023	3	9	120	100	80	9	106	F120	0.5
	3.5	9	140	115	95	9	115	F140	0.8
	3.5	9	160	130	110	9	126	F160	1.1
	3.5	11	200	165	130	11	165	F200	1.8
033	3.5	11	160	130	110	9	140	F160	1.0
	3.5	11	200	165	130	11	165	F200	1.8
	4	13	250	215	180	14	215	F250	2.9
043	3.5	11	160	130	110	9	140	F160	1.0
	3.5	11	200	165	130	11	165	F200	1.8
	4	13	250	215	180	14	215	F250	2.9

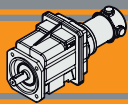

### Dimensioni

### Dimensions

Versione H / H Version											Combinazioni possibili H/F Possible combinations H/F						
CMG	P	Q	R	S	U	V	X	Z	Piede / Foot		F105	F120	F140	F160	F200	F250	F300
									Tipo / Type	Peso / Weight [kg]							
002	18	60	80	9	100	10	60	120	H60	0.2	•	•	•				
	18	80	104	9	110 - 120	10	75	145	H75	0.3	•	•	•				
	18	50 - 87	110	9	110	10	85	135	H85	0.4	•	•	•				
012 013	20	85	108	9	115	12	65	139	H65	0.7		•	•				
	18	80	118	9	110	12	75	140	H75	1.0		•	•	•			
	25	85	120	9	120	12	80	140	H80	1.1		•	•	•			
	18	50 - 87	118	9	110	12	85	130	H85	1.2		•	•	•			
	25	130	154	9	110	12	90	135	H90	1.5		•	•	•	•		
	18	60 - 107.5	135	11	130	12	100	155	H100	1.7		•	•	•	•		
022 023	20	85	108	9	115	12	65	139	H65	0.7		•	•				
	18	80	118	9	110	12	75	140	H75	1.0		•	•	•			
	25	85	120	9	120	12	80	140	H80	1.1		•	•	•			
	18	50 - 87	118	9	110	12	85	130	H85	1.2		•	•	•			
	25	130	154	9	110	12	90	135	H90	1.5		•	•	•	•		
	18	60 - 107.5	135	11	130	12	100	155	H100	1.7		•	•	•	•		
033	30	105	136	14	160	14	95	194	H95	1.5				•	•		
	30	100	150	11	150	14	110	185	H110	1.9				•	•		
	18	70			160												
	30	165	195	14	135	14	115	170	H115	2.2				•	•	•	
	35	110	160	14	170	14	120	210	H120	2.6				•	•	•	
043	30	105	136	14	160	14	95	194	H95	1.5				•	•		
	30	100	150	11	150	14	110	185	H110	1.9				•	•		
	18	70			160												
	30	165	195	14	135	14	115	170	H115	2.2				•	•	•	
	35	110	160	14	170	14	120	210	H120	2.6				•	•	•	

■ Preferenziale / Preferred

• Combinazioni possibili H/F / Possible combinations H/F

Versione F / F Version									
CMG	H	K	L	M	N f7	O	P	Flangia / Flange	
								Tipo / Type	Peso / Weight [kg]
002	3.5	7	105	85	70	6.5	90	F105	0.1
	3.5	8	120	100	80	7	100	F120	0.2
	3.5	8	140	115	95	9	115	F140	0.2
012 013	3	9	120	100	80	9	106	F120	0.5
	3.5	9	140	115	95	9	115	F140	0.8
	3.5	9	160	130	110	9	126	F160	1.1
	3.5	11	200	165	130	11	165	F200	1.8
022 023	3	9	120	100	80	9	106	F120	0.5
	3.5	9	140	115	95	9	115	F140	0.8
	3.5	9	160	130	110	9	126	F160	1.1
	3.5	11	200	165	130	11	165	F200	1.8
033	3.5	11	160	130	110	9	140	F160	1.0
	3.5	11	200	165	130	11	165	F200	1.8
	4	13	250	215	150	14	215	F250	2.9
043	3.5	11	160	130	110	9	140	F160	1.0
	3.5	11	200	165	130	11	165	F200	1.8
	4	13	250	215	150	14	215	F250	2.9

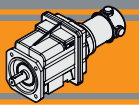

Dimensioni

Dimensions

**NDCMG..H../F..**

**NDCMG..2 H../F..**

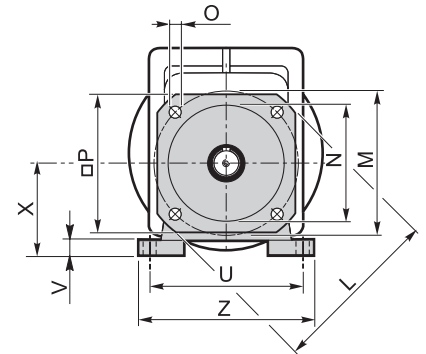
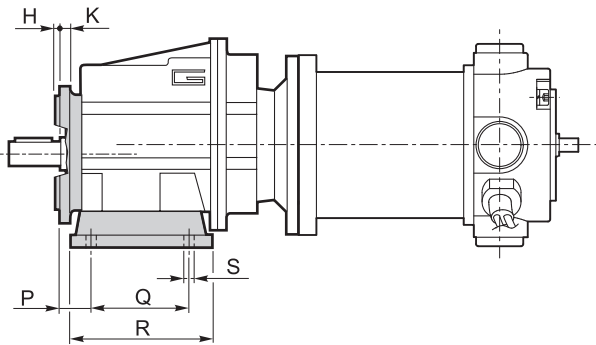

**NDCMG..3 H../F..**

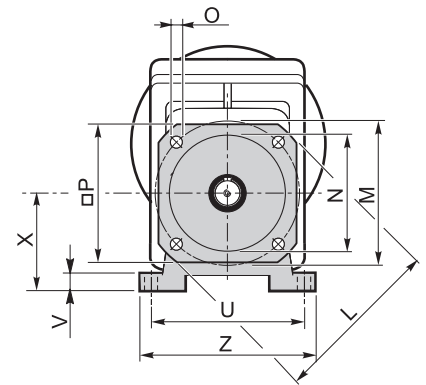
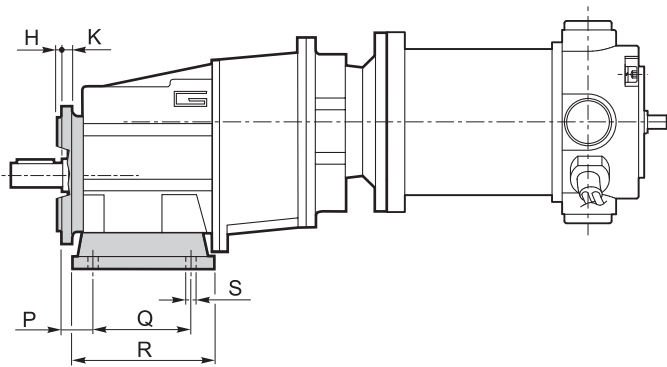

NDCMG



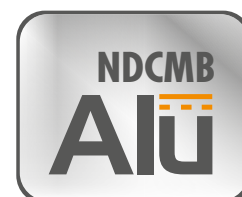

Neodymium

## Motoriduttori CC ad assi ortogonali DC helical bevel gearmotors

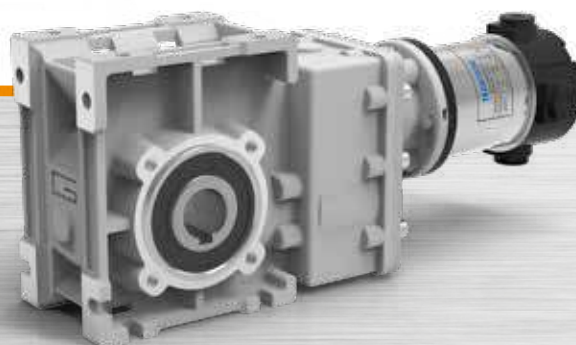



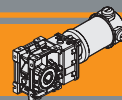

<b>Indice</b>	<b>Index</b>	Pag. Page
Caratteristiche tecniche	<i>Technical features</i>	<b>D2</b>
Designazione	<i>Classification</i>	<b>D2</b>
Sensi di rotazione	<i>Direction of rotation</i>	<b>D2</b>
Simbologia	<i>Symbols</i>	<b>D3</b>
Lubrificazione	<i>Lubrication</i>	<b>D3</b>
Carichi radiali	<i>Radial loads</i>	<b>D3</b>
Dati tecnici	<i>Technical data</i>	<b>D4</b>
Motori applicabili	<i>Motor adapters</i>	<b>D4</b>
Dimensioni	<i>Dimensions</i>	<b>D5</b>
Accessori	<i>Accessories</i>	<b>D8</b>

Questa sezione annulla e sostituisce ogni precedente edizione o revisione. Qualora questa sezione non Vi sia giunta in distribuzione controllata, l'aggiornamento dei dati ivi contenuto non è assicurato. **In tal caso la versione più aggiornata è disponibile sul nostro sito internet [www.transtecno.com](http://www.transtecno.com)**

*This section replaces any previous edition and revision. If you obtained this catalogue other than through controlled distribution channels, the most up to date content is not guaranteed. **In this case the latest version is available on our web site [www.transtecno.com](http://www.transtecno.com)***

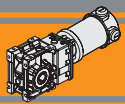

### Caratteristiche tecniche

### Technical features

Le caratteristiche principali dei motoriduttori CC ad assi ortogonali a magneti permanenti in neodimio NDCMB sono:

The main features of NDCMB neodymium permanent magnets DC helical bevel gearmotors range are:

- Alimentazione in bassa tensione 12/24 Vcc
- Possibilità di montaggio encoder
- Potenze motore disponibili da 160 a 250W S2
- Magneti in Neodimio
- Carcasse dei riduttori in pressofusione di alluminio
- Lubrificazione permanente con olio sintetico
- Ingranaggi sempre rettificati

- Low voltage power supply 12/24 Vdc
- Suitable for encoder assembly
- Motor power ratings available from 160 to 250W S2
- Neodymium magnets
- Die-cast aluminum housing
- Permanent synthetic oil long-life lubrication
- Ground helical gears

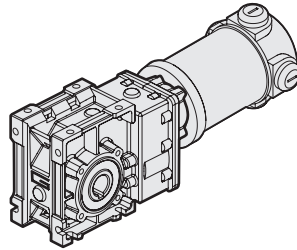

### Designazione

### Classification

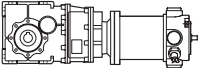
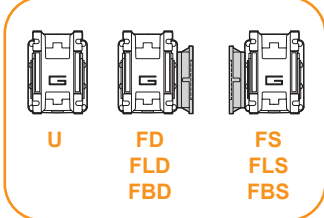
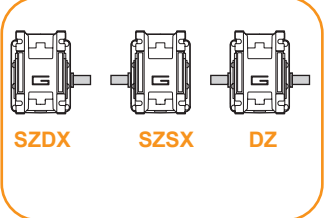
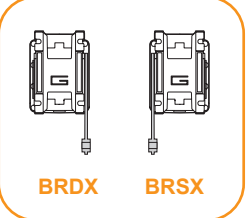
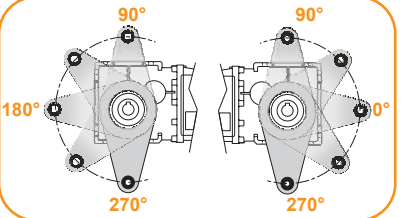
MOTORIDUTTORE / GEARMOTOR									
NDCMB	120/402		U	9.2	D20	SZDX	BRSX	90	240
Tipo Type	Grandezza Size		Versione Riduttore Gearbox Version	Rapporto Ratio	Albero di uscita Output shaft	Albero di uscita Output shaft	Braccio di reazione Torque arm	Angolo Angle	Versione Motore Motor Version
	120/402	180/402	U	Vedere tabella See tables	Vedere tabella See tables	SZDX SZSX DZ	BRDX BRSX	0° 90° 180° 270°	120 240
Versione Riduttore Gearbox Version	Albero di uscita Output shaft		Braccio di reazione (*) Torque arm		Angolo (*) Angle				
									

(\*) NOTA:  
Il braccio di reazione viene fornito smontato.  
NOTE:  
The torque arm will be supplied not assembled

### Sensi di rotazione

### Direction of rotation

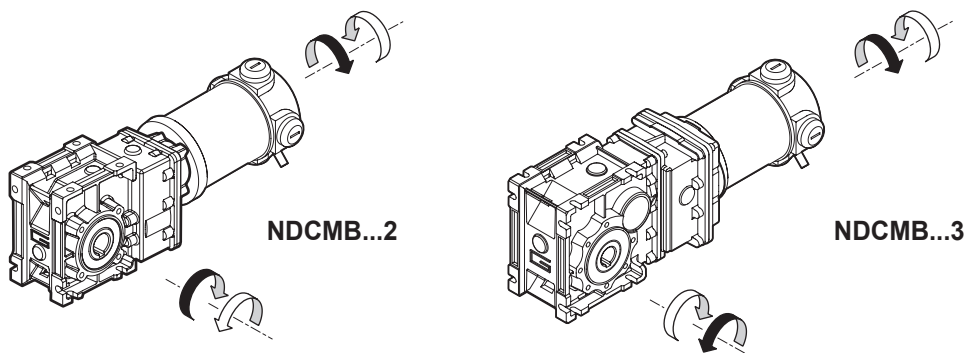

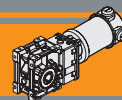

**Simbologia**

**Symbols**

$n_1$ [min <sup>-1</sup> ]	Velocità in ingresso / <i>Input speed</i>	$M_2$ [Nm]	Coppia in uscita in funzione di $P_1$ / <i>Output torque referred to <math>P_1</math></i>
$n_2$ [min <sup>-1</sup> ]	Velocità in uscita / <i>Output speed</i>	sf	Fattore di servizio / <i>Service factor</i>
i	Rapporto di riduzione / <i>Ratio</i>	$A_2$ [N]	Carico assiale ammissibile in uscita / <i>Permitted output axial load</i>
$P_1$ [kW]	Potenza in entrata / <i>Input power</i>	$R_2$ [N]	Carico radiale ammissibile in uscita / <i>Permitted output radial load</i>

**Lubrificazione**

**Lubrication**

Tutti i riduttori nelle taglie 402 e 502 sono forniti completi di lubrificante sintetico viscosità 320, pertanto possono essere installati in qualunque posizione di montaggio e non necessitano di manutenzione.

*Permanent synthetic oil long-life lubrication (viscosity grade 320) makes it possible to use sizes 402 and 502 in all mounting positions; for this reason they can be installed in any assembly position and do not require maintenance.*

**Carichi radiali**

**Radial loads**

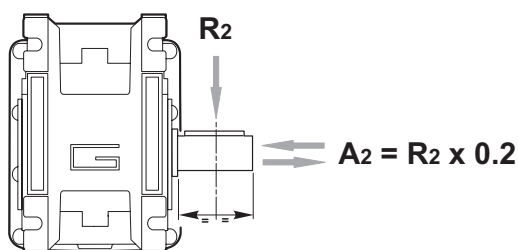

$n_2$ [min <sup>-1</sup> ]	$R_2$ [N]		
	CMB 402	CMB 502	CMB 633
400	905	1116	1835
300	996	1228	2020
200	1141	1406	2312
170	1204	1484	2441
140	1414	1743	2604
100	1582	1949	2913
90	1638	2019	3321
60	2047	2490	3801
40	2524	3029	4492
30	2778	3334	5159
20	3180	3816	5906
15	3500	4200	6500
10	3500	4200	6500

Quando il carico radiale risultante non è applicato sulla mezzeria dell'albero occorre calcolare quello effettivo con la seguente formula:

*When the resulting radial load is not applied on the centre line of the shaft it is necessary to calculate the effective load with the following formula:*

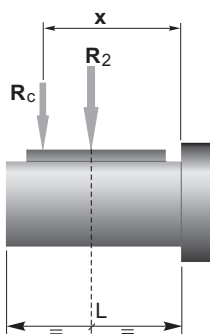

	CMB 402	CMB 502	CMB 633
a	86	104	118
b	66	79	93
$R_{2MAX}$	3500	4200	6500

$$R_c = \frac{R_2 \cdot a}{(b + x)} \leq R_{2MAX}$$

$$R \leq R_c$$

*a, b = valori riportati nella tabella  
a, b = values given in the table*

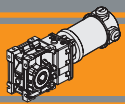

### Dati tecnici per servizio S2

### Technical data for S2 duty

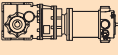
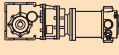
$P_1$ [W]	$n_2$ [min <sup>-1</sup> ]	$M_2$ [Nm]	sf	i		Versione motore Motor version	$P_1$ [W]	$n_2$ [min <sup>-1</sup> ]	$M_2$ [Nm]	sf	i		Versione motore Motor version
<b>160</b>							<b>250</b>						
(3000 min <sup>-1</sup> )	<b>485</b>	3.0	10.5	6.18	<b>120/402</b>	120/240	(3000 min <sup>-1</sup> )	<b>485</b>	4.6	6.7	6.18	<b>180/402</b>	120/240
	<b>401</b>	3.6	8.6	7.49									
	<b>326</b>	4.4	7.0	9.20									
	<b>254</b>	5.7	6.2	11.83									
	<b>240</b>	6.0	5.9	12.48									
	<b>202</b>	7.1	4.9	14.83									
	<b>170</b>	8.4	4.1	17.63									
	<b>161</b>	8.9	4.8	18.60									
	<b>134</b>	10	4.0	22.33									
	<b>125</b>	11	3.8	23.91									
	<b>104</b>	14	3.7	28.89									
	<b>97</b>	15	3.5	30.84									
	<b>89</b>	16	3.2	33.57									
	<b>84</b>	17	3.0	35.63									
	<b>70</b>	21	2.5	42.75									
	<b>54</b>	27	1.9	55.31									
	<b>51</b>	29	1.8	59.06									
	<b>47</b>	31	1.7	64.29									
	<b>41</b>	35	1.5	72.50									
	<b>70</b>	21	4.8	42.75	<b>120/502</b>	120/240		<b>134</b>	17	5.1	22.33	<b>180/502</b>	120/240
	<b>54</b>	27	3.7	55.31									
	<b>51</b>	28	3.5	59.06									
	<b>47</b>	31	3.2	64.29									
	<b>41</b>	35	2.8	72.50									
	<b>41</b>	35	5.5	73.96	<b>120/633</b>	120/240		<b>52</b>	43	4.5	57.93	<b>180/633</b>	120/240
	<b>38</b>	38	5.2	78.58									
	<b>32</b>	45	4.4	93.33									
	<b>21</b>	67	2.9	140.52									
	<b>17</b>	87	2.2	181.81									
	<b>14</b>	101	1.9	211.31									
	<b>13</b>	114	1.7	238.31									
							<b>49</b>	46	4.2	61.63			
							<b>41</b>	55	3.5	73.96			
							<b>38</b>	59	3.3	78.58			
							<b>32</b>	70	2.8	93.33			
							<b>21</b>	105	1.9	140.52			
							<b>17</b>	136	1.4	181.81			
							<b>14</b>	158	1.2	211.31			
							<b>13</b>	178	1.1	238.31			

**NOTA:** per servizio continuo o altamente intermittente, contattare il servizio tecnico

**NOTE:** for continuous or highly intermittent duty, please contact our technical service

### Motori applicabili

### Motor adapters

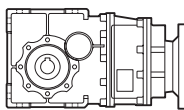
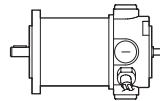

		ND	
		120.120 120.240	180.120 180.240
CMB	402	6.18 - 72.50	
	502	6.18 - 72.50	
	633	6.58 - 238.31	

Rapporti di riduzione i  
Ratio i

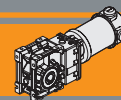

Dimensioni

Dimensions

NDCMB120/402 U  
NDCMB180/402 U

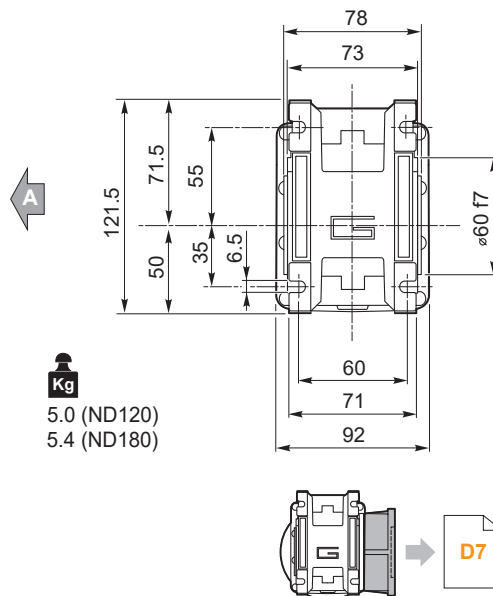
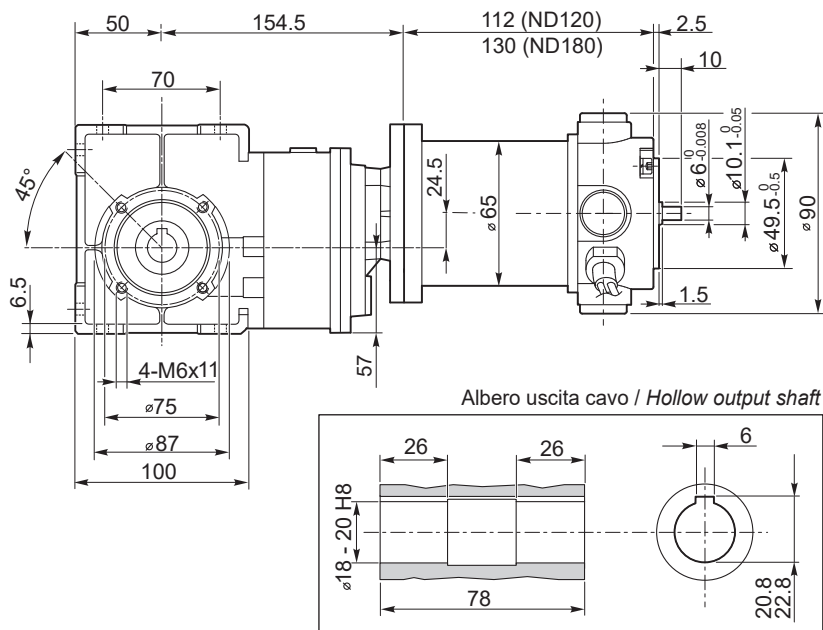

**Kg**  
5.0 (ND120)  
5.4 (ND180)

NDCMB

NDCMB120/502 U  
NDCMB180/502 U

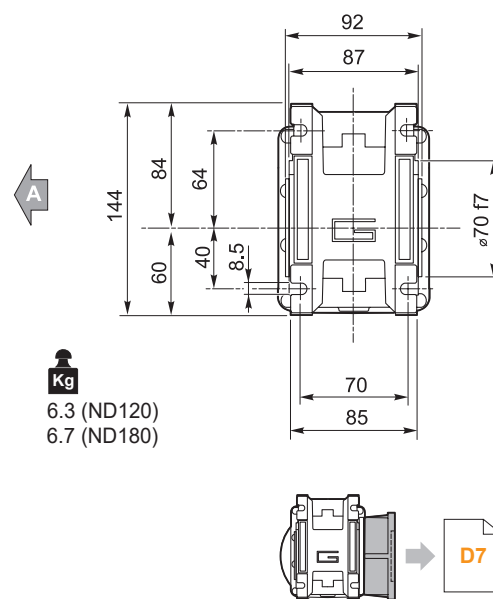
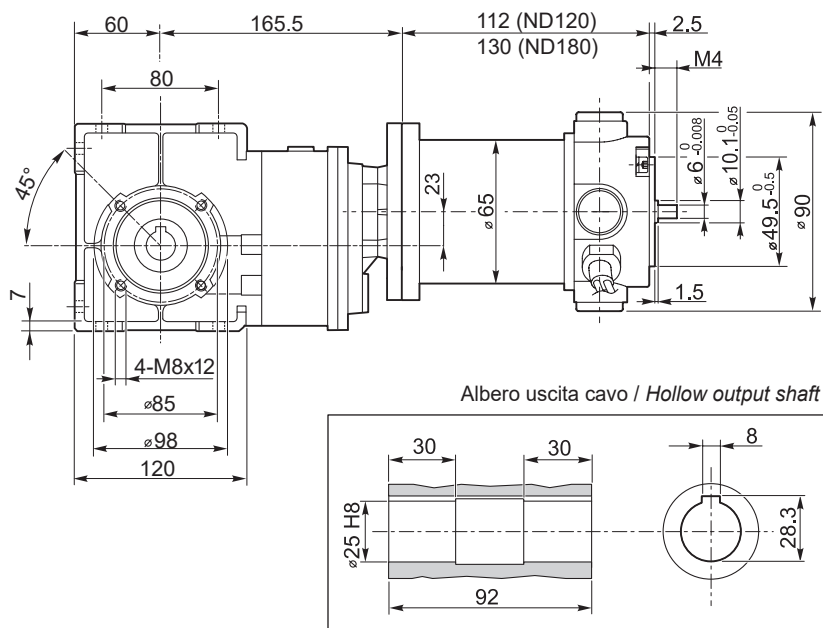

**Kg**  
6.3 (ND120)  
6.7 (ND180)

Vista da A  
View from A

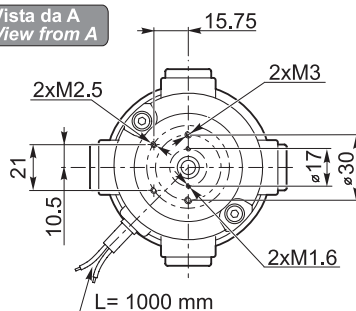

Freno / Brake → B9

Encoder → B9

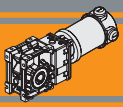

### Dimensioni

### Dimensions

#### NDCMB120/633 U NDCMB180/633 U

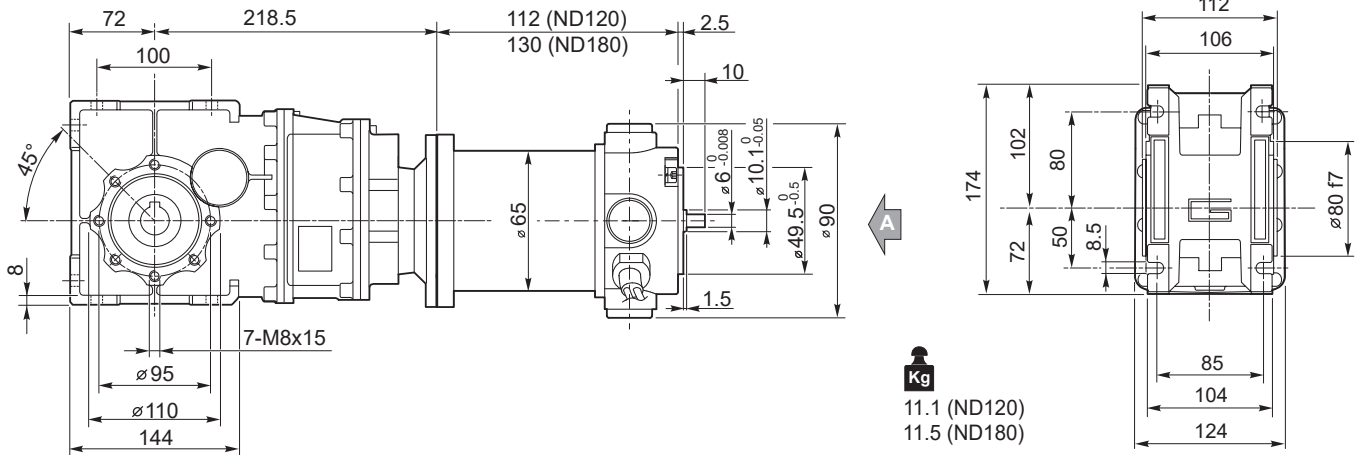

Albero uscita cavo / Hollow output shaft

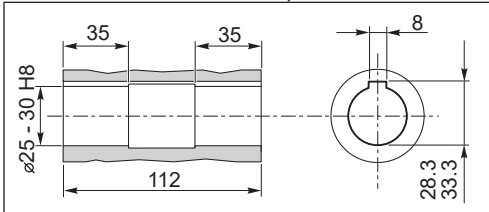

Vista da A  
View from A

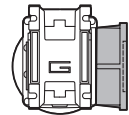
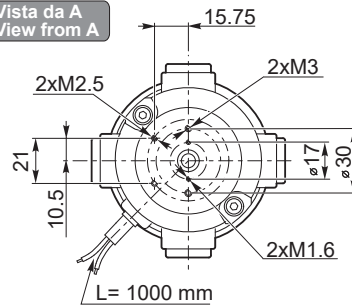

D7

Freno / Brake



B9

Encoder



B9

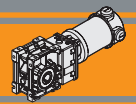

**Dimensioni**

**Dimensions**

**NDCMB.../... F...** Flange uscita / Output flanges

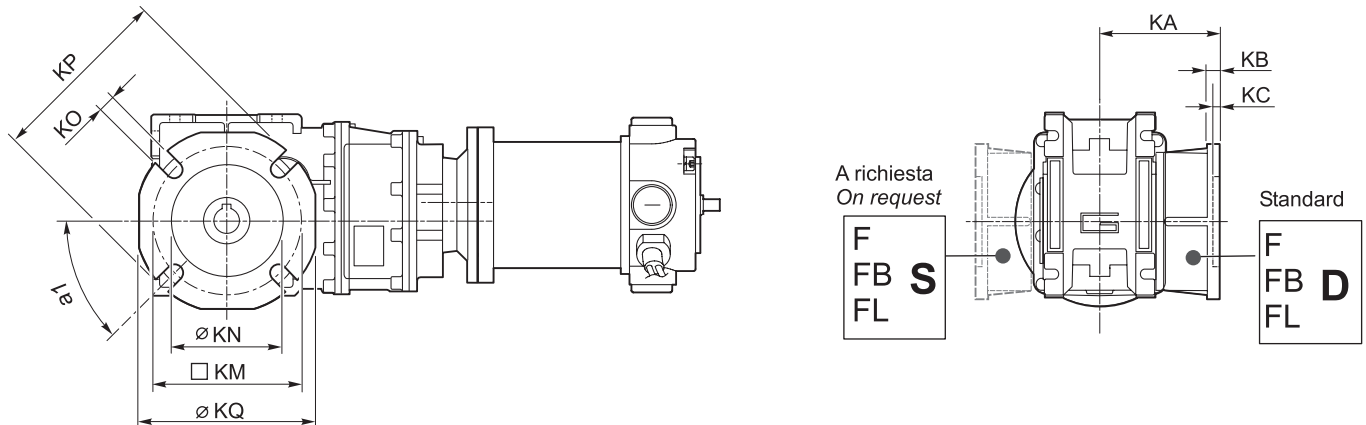

**NDCMB**

CMB	Flange uscita / Output flanges																										
	F									FL									FB								
	a <sub>1</sub>	KA	KB	KC	KM	KN H8	KO	KP	KQ	a <sub>1</sub>	KA	KB	KC	KM	KN H8	KO	KP	KQ	a <sub>1</sub>	KA	KB	KC	KM	KN H8	KO	KP	KQ
<b>402</b>	45°	67	7.5	4.5	80-95	60	9	110	95	45°	97	7.5	4.5	80-95	60	9	110	95	45°	80	8.5	5	115-125	95	9.5	140	112
<b>502</b>	45°	90	9	5	90-110	70	11	125	110	45°	120	9	5	90-110	70	11	125	110	45°	89	9	5	130-145	110	9.5	160	132
<b>633</b>	45°	82	10	6	150 - 160	115	11	180	142	45°	112	10	8	150 - 160	115	11	180	142	45°	98	11	5	165	130	11	200	160

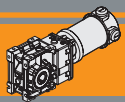

### Accessori

### Accessories

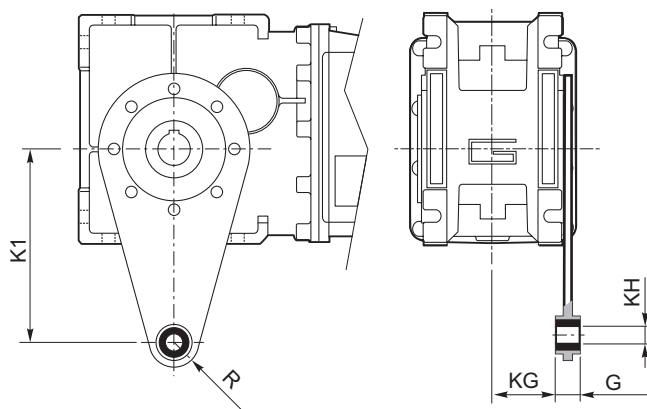
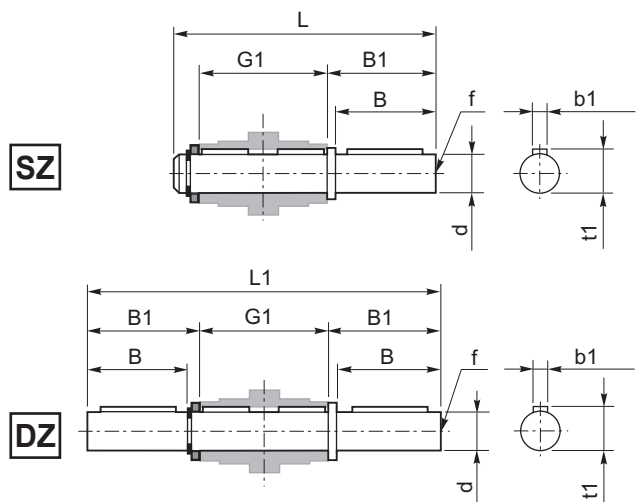

Albero lento / Output shaft

CMB	d h7	B	B1	G1	L	L1	f	b1	t1
402	18	40	43	78	128	164	M6	6	20.5
502	25	50	53.5	92	153	199	M10	8	28
633	25	50	53.5	112	173	219	M10	8	28

Braccio di reazione / Torque arm

CMB	K1	G	KG	KH	R
402	100	14	31	10	18
502	100	14	38	10	18
633	150	14	47.5	10	18

### SC - Safety cover

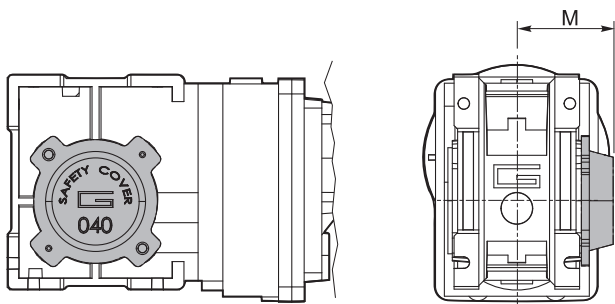

CMB	M
402	54.5
502	62.5
633	73

### WD - Washdown cover

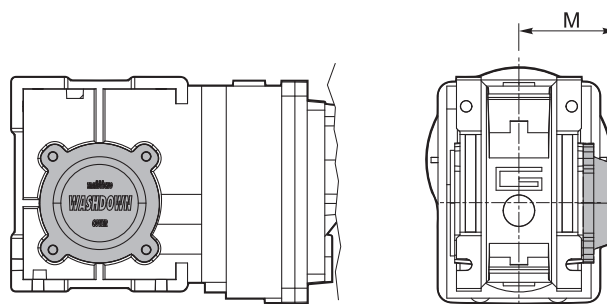

CMB CMBIS	M
402	55.5
502	63.5
633	71.5



Neodymium

Motoriduttori CC pendolari  
**DC helical parallel gearmotors**





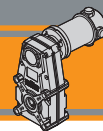

<b>Indice</b>	<b>Index</b>	Pag. Page
Caratteristiche tecniche	<i>Technical features</i>	<b>E2</b>
Designazione	<i>Classification</i>	<b>E2</b>
Sensi di rotazione	<i>Direction of rotation</i>	<b>E3</b>
Simbologia	<i>Symbols</i>	<b>E3</b>
Lubrificazione	<i>Lubrication</i>	<b>E3</b>
Carichi radiali	<i>Radial loads</i>	<b>E4</b>
Dati tecnici	<i>Technical data</i>	<b>E5</b>
Motori applicabili	<i>Motor adapters</i>	<b>E5</b>
Dimensioni	<i>Dimensions</i>	<b>E6</b>

Questa sezione annulla e sostituisce ogni precedente edizione o revisione. Qualora questa sezione non Vi sia giunta in distribuzione controllata, l'aggiornamento dei dati ivi contenuto non è assicurato. **In tal caso la versione più aggiornata è disponibile sul nostro sito internet [www.transtecno.com](http://www.transtecno.com)**

*This section replaces any previous edition and revision. If you obtained this catalogue other than through controlled distribution channels, the most up to date content is not guaranteed. **In this case the latest version is available on our web site [www.transtecno.com](http://www.transtecno.com)***



# NDFT Motoriduttori CC pendolari DC Helical parallel gearmotors

## Caratteristiche tecniche

## Technical features

I motoriduttori CC pendolari a magneti permanenti in neodimio NDFT hanno le seguenti caratteristiche principali:

NDFT neodymium permanent magnets DC helical parallel gearmotors range has the following main features:

- Alimentazione in bassa tensione 12/24 Vcc
  - Possibilità di montaggio encoder e freno
  - Potenze motore disponibili da 160 a 250W S2
  - Magneti in Neodimio
  - Carcasse dei riduttori in pressofusione di alluminio
  - Lubrificazione permanente con olio sintetico
  - Ingranaggi cilindrici a denti elicoidali.
- Low voltage power supply 12/24 Vdc
  - Suitable for encoder and brake assembly
  - Motor power ratings available from 160 to 250W S2
  - Neodymium magnets
  - Die-cast aluminum housing
  - Permanent synthetic oil long-life lubrication
  - helical gears.

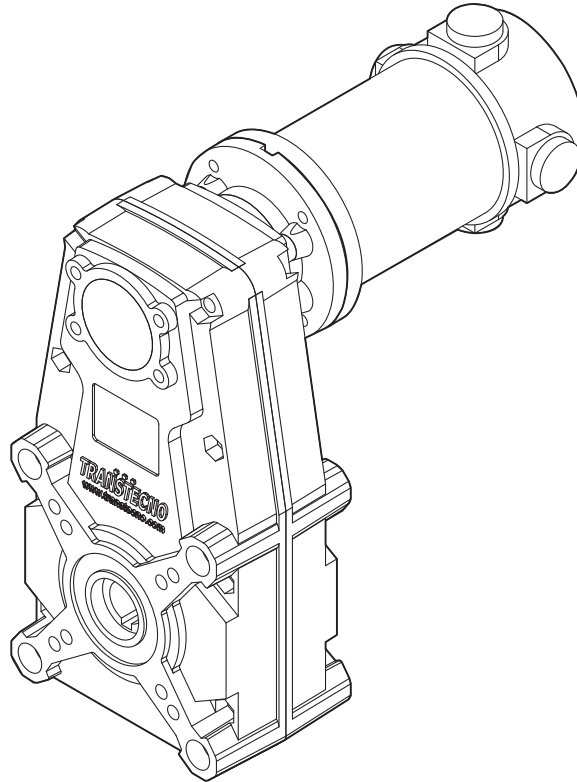

## Designazione

## Classification

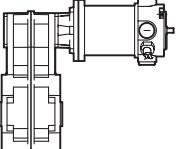
MOTORIDUTTORE / GEARMOTOR						
NDFT	120/146		U	60.63	O20	240
Tipo Type	Grandezza Size		Versione Riduttore Gearbox Version	Rapporto Ratio	Albero di uscita Output shaft	Versione Motore Motor Version
NDFT 	120/105/3 120/105/4 120/146	180/105/3 180/146	U...	Vedere tabella See tables	Vedere tabella See tables	120  240

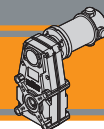

Sensi di rotazione

Direction of rotation

FT105/3  
FT146

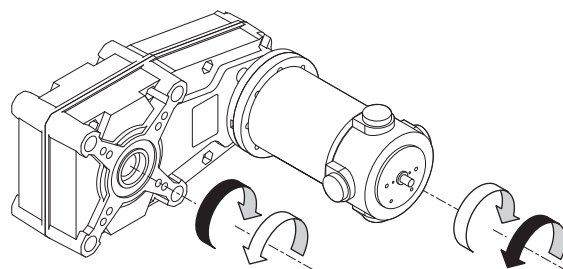
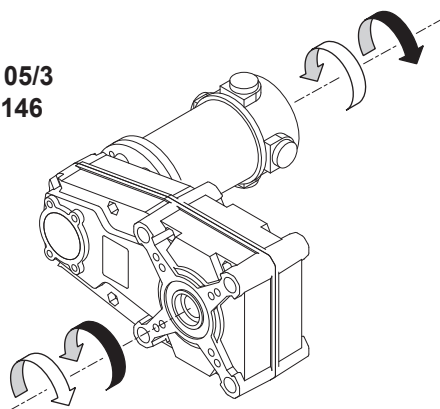

FT105/4

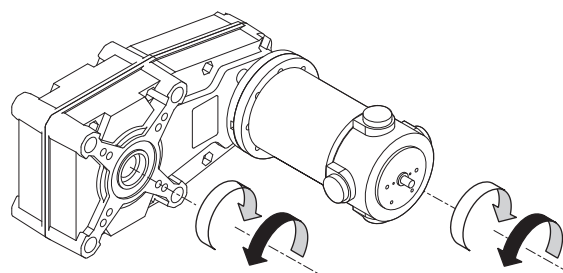
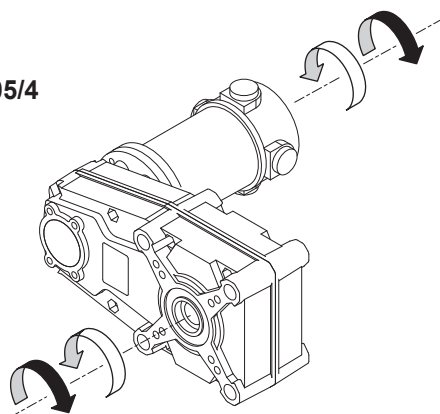

NDFT

Simbologia

Symbols

$n_1$	[min <sup>-1</sup> ]	Velocità in ingresso / <i>Input speed</i>
$n_2$	[min <sup>-1</sup> ]	Velocità in uscita / <i>Output speed</i>
$i$		Rapporto di riduzione / <i>Ratio</i>
$P_1$	[kW]	Potenza in entrata / <i>Input power</i>
$M_2$	[Nm]	Coppia nominale in uscita in funzione di $P_1$ / <i>Output torque referred to <math>P_1</math></i>
$P_{n1}$	[kW]	Potenza nominale in entrata / <i>Nominal input power</i>
$M_{n2}$	[Nm]	Coppia nominale in uscita in funzione di $P_{n1}$ / <i>Nominal output torque referred to <math>P_{n1}</math></i>
$sf$		Fattore di servizio / <i>Service factor</i>
$R_2$	[N]	Carico radiale ammissibile in uscita / <i>Permitted output radial load</i>
$A_2$	[N]	Carico assiale ammissibile in uscita / <i>Permitted output axial load</i>

Lubrificazione

Lubrication

Tutti i motoriduttori sono forniti completi di lubrificante sintetico viscosità 320, pertanto possono essere installati in qualunque posizione di montaggio e non necessitano di manutenzione.

*Permanent synthetic oil long-life lubrication ( viscosity grade 320) makes it possible to use the gearmotors in all mounting positions; for this reason they can be installed in any assembly position and do not require maintenance.*



## Carichi radiali

## Radial loads

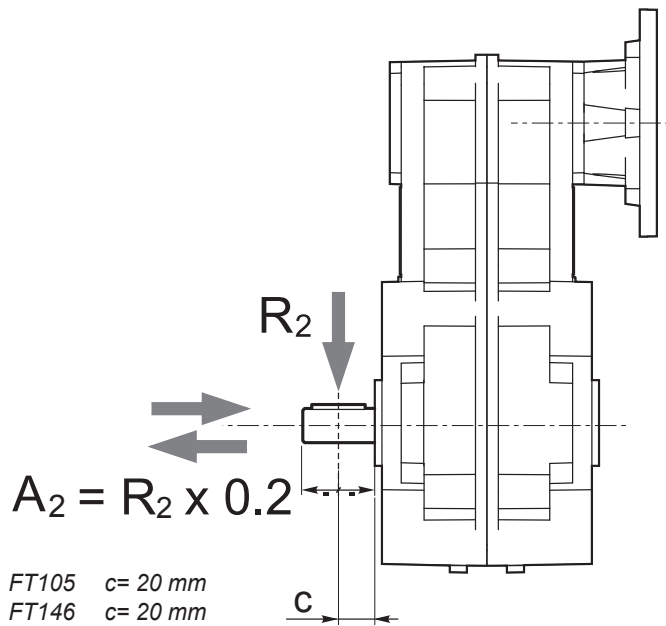

$n_2$ [min <sup>-1</sup> ]	$R_2$ [N]	
	FT105	FT146
200	800	1400
170	900	1600
140	1000	1800
120	1100	2000
100	1300	2200
70	1500	2500
50	1600	2600
40	1700	2700
30	1850	2850
20	2000	3000
10	2000	3000
5	2000	3000

Quando il carico radiale risultante non è applicato sulla mezza-  
ria dell'albero occorre calcolare quello effettivo con la seguente  
formula:

When the resulting radial load is not applied on the centre line  
of the shaft it is necessary to calculate the effective load with the  
following formula:

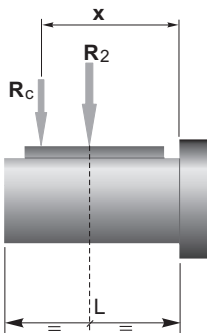

	FT105	FT146
<b>a</b>	82	82,5
<b>b</b>	62	62,5
<b>R<sub>2MAX</sub></b>	2000	3000

$$R_c = \frac{R_2 \cdot a}{(b+x)} \leq R_{2MAX}$$

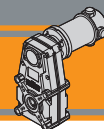

*a, b = valori riportati nella tabella  
a, b = values given in the table*

$$R \leq R_c$$



## Dati tecnici

## Technical data

$P_1$ [W]	$n_2$ [min <sup>-1</sup> ]	$M_2$ [Nm]	sf	i		Versione motore Motor version	$P_1$ [W]	$n_2$ [min <sup>-1</sup> ]	$M_2$ [Nm]	sf	i		Versione motore Motor version		
<b>160</b>							<b>250</b>								
(3000 min <sup>-1</sup> )	<b>146</b>	10	3.2	20.57	<b>120/105/3</b>	120/240	(3000 min <sup>-1</sup> )	<b>146</b>	15	2.0	20.57	<b>180/105/3</b>	120/240		
	<b>90</b>	16	2.4	33.32				<b>90</b>	25	1.6	33.32				
	<b>68</b>	21	2.4	44.36				<b>68</b>	33	1.5	44.36				
	<b>55</b>	26	1.9	54.87				<b>55</b>	41	1.2	54.87				
	<b>42</b>	34	1.5	71.84				<b>42</b>	54	0.9	71.84				
	<b>39</b>	37	1.4	77.07				<b>39</b>	58	0.9	77.07				
	<b>34</b>	43	1.2	88.87				<b>34</b>	66	0.8	88.87				
	<b>24</b>	60	0.8	124.81											
	<b>17</b>	86	0.6	181.35				<b>160</b>	14	4.4	18.75			<b>180/146</b>	120/240
	<b>13</b>	86	0.6	224.32				<b>131</b>	17	5.0	22.89				
	<b>9.5</b>	86	0.6	315.05		<b>115</b>	20	3.2	26.17						
						<b>106</b>	21	3.0	28.26						
	<b>8.1</b>	86	0.6	368.19	<b>120/105/4</b>	120/240	<b>86</b>	26	3.0	35.07					
	<b>5.6</b>	86	0.6	534.98				<b>76</b>	30	2.6	39.44				
	<b>4.5</b>	86	0.6	661.76				<b>65</b>	35	2.2	46.44				
	<b>3.2</b>	86	0.6	929.40				<b>57</b>	40	2.0	52.86				
	<b>160</b>	9	7.0	18.75	<b>120/146</b>	120/240	<b>49</b>	45	1.9	60.63					
	<b>131</b>	11	5.7	22.89				<b>43</b>	52	1.6	70.00				
	<b>115</b>	13	5.0	26.17				<b>41</b>	55	1.5	74.02				
	<b>106</b>	14	4.6	28.26				<b>35</b>	63	1.4	84.63				
	<b>86</b>	17	4.6	35.07				<b>31</b>	72	1.2	95.61				
	<b>76</b>	19	4.1	39.44				<b>26</b>	85	1.0	113.40				
	<b>65</b>	22	3.5	46.44				<b>22</b>	100	0.9	133.45				
	<b>57</b>	25	3.1	52.86				<b>20</b>	112	0.8	150.18				
	<b>49</b>	29	3.0	60.63				<b>19</b>	120	0.8	160.43				
	<b>43</b>	34	2.6	70.00				<b>17</b>	134	0.7	178.83				
	<b>41</b>	35	2.4	74.02											
	<b>35</b>	41	2.1	84.63											
	<b>31</b>	46	1.9	95.61											
	<b>26</b>	54	1.6	113.40											
	<b>22</b>	64	1.3	133.45											
	<b>20</b>	72	1.2	150.18											
	<b>19</b>	77	1.2	160.43											
	<b>17</b>	86	1.1	178.83											
	<b>15</b>	94	1.0	195.85											
	<b>13</b>	107	0.9	223.92											
	<b>13</b>	113	0.8	236.83											
	<b>10</b>	134	0.7	300.07											
	<b>7.5</b>	134	0.7	397.38											

N.B.  
Verificare sempre che la coppia M2 utilizzata non ecceda il valore indicato nelle caselle in grigio

N.B.  
Please check that the output torque M2 does not exceed the value in the grey areas

**NOTA:** per servizio continuo o altamente intermittente, contattare il servizio tecnico

**NOTE:** for continuous or highly intermittent duty, please contact our technical service

## Motori applicabili

## Motor adapters

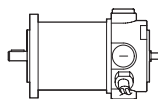

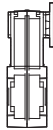
		ND	
		120.120 120.240	180.120 180.240
	<b>105/3</b>	20.57 - 315.05	20.57 - 315.05
	<b>105/4</b>	368.19 - 929.4	368.19 - 929.4
	<b>146</b>	18.75 - 397.38	18.75 - 397.38

18.75 - 397.38

Rapporti di riduzione i  
Ratio i



Dimensioni

Dimensions

### NDFT 120/105

#### NDFT 120/105...U

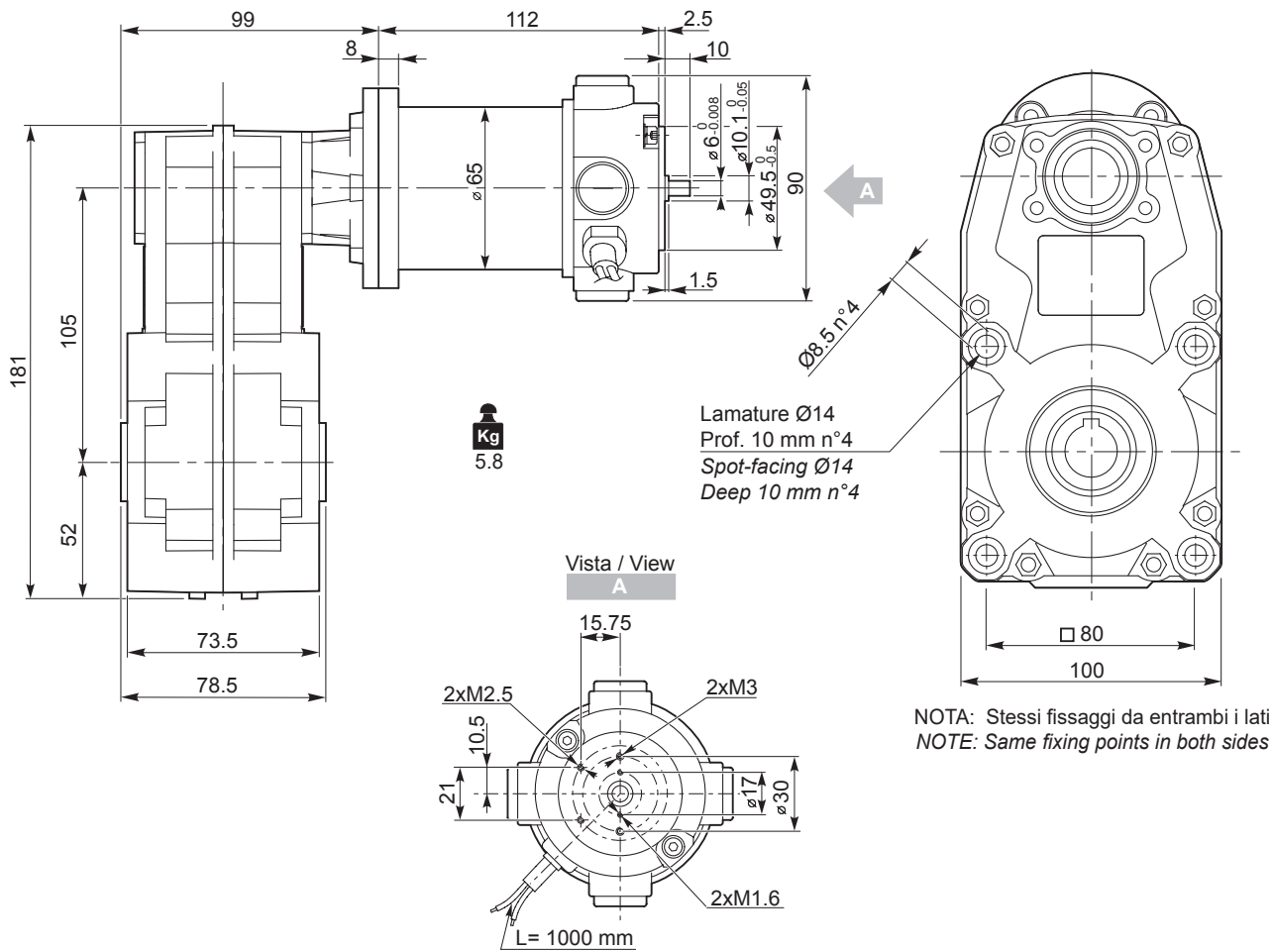

#### O17

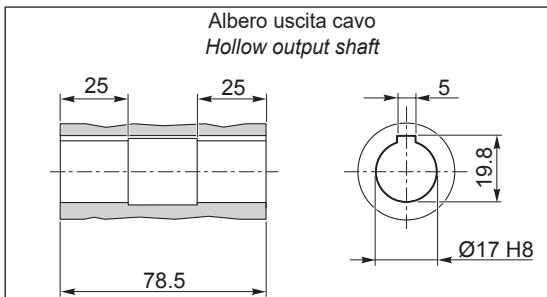

#### O20

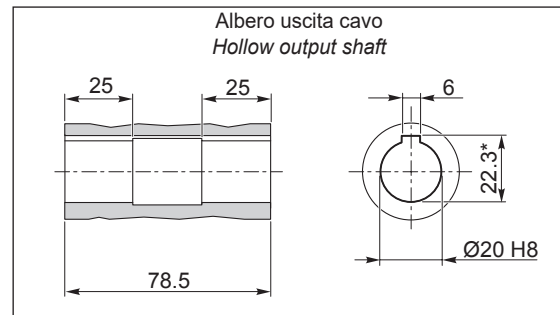

\*: Sede linguetta ribassata / Special keyway

Freno / Brake



Encoder



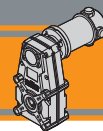

**NDFT 180/105**

**NDFT 180/105...U**

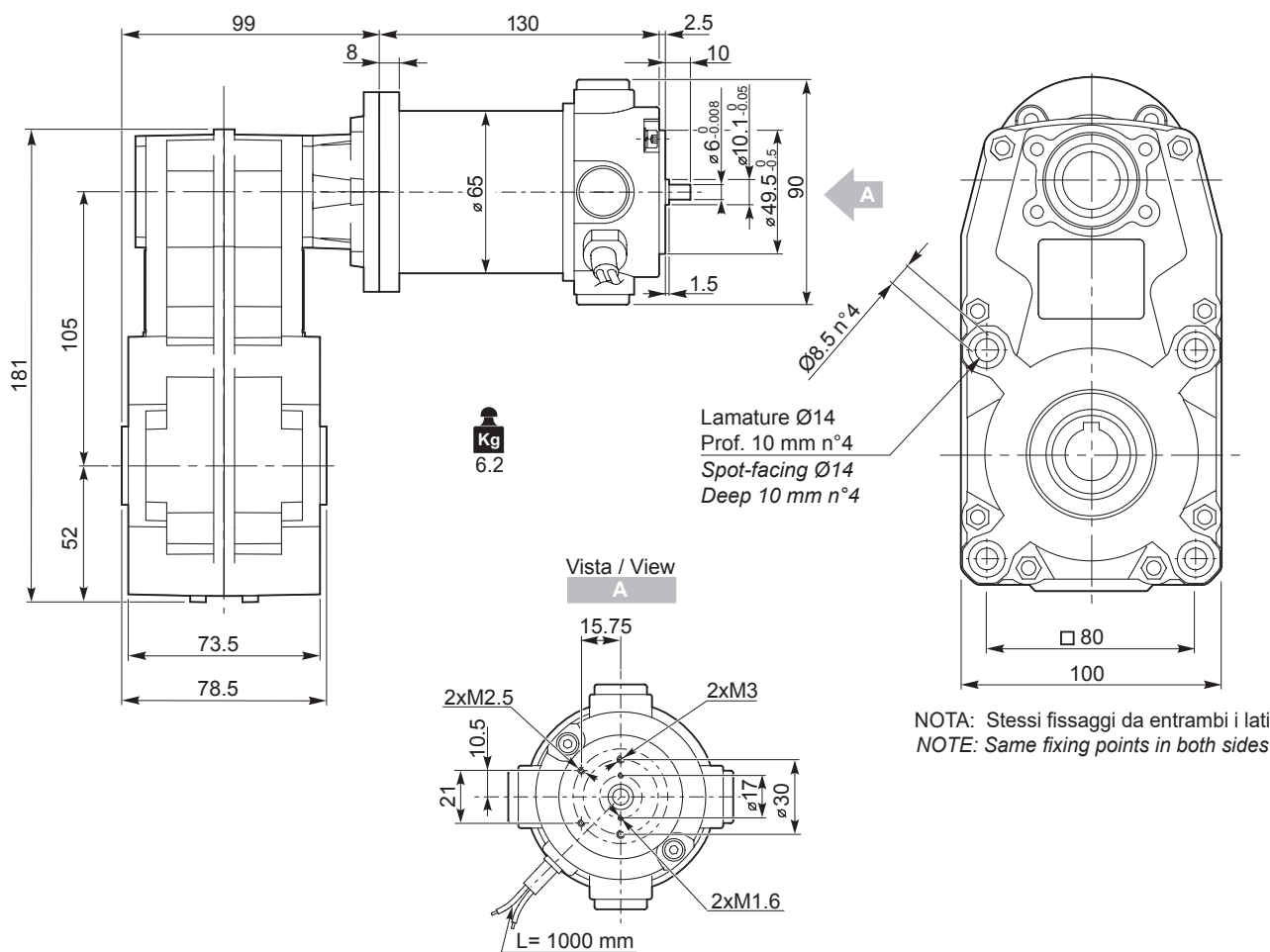

NDFT

**O17**

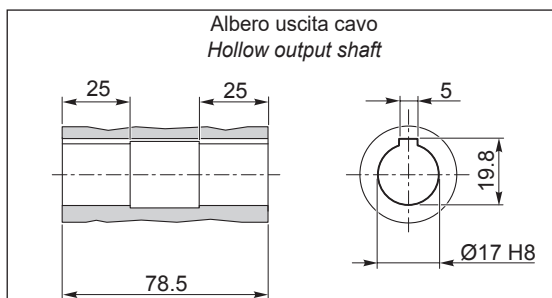

**O20**

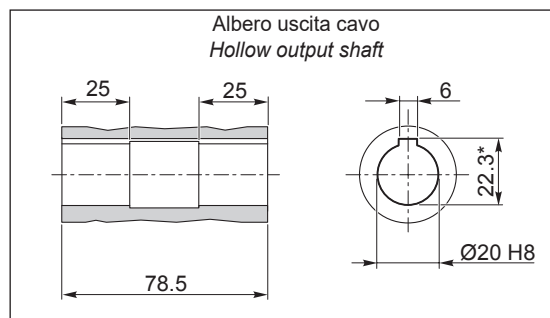

\*: Sede linguetta ribassata / Special keyway

Freno / Brake

B9

Encoder

B9



## NDFT 120/146

### NDFT 120/146...U

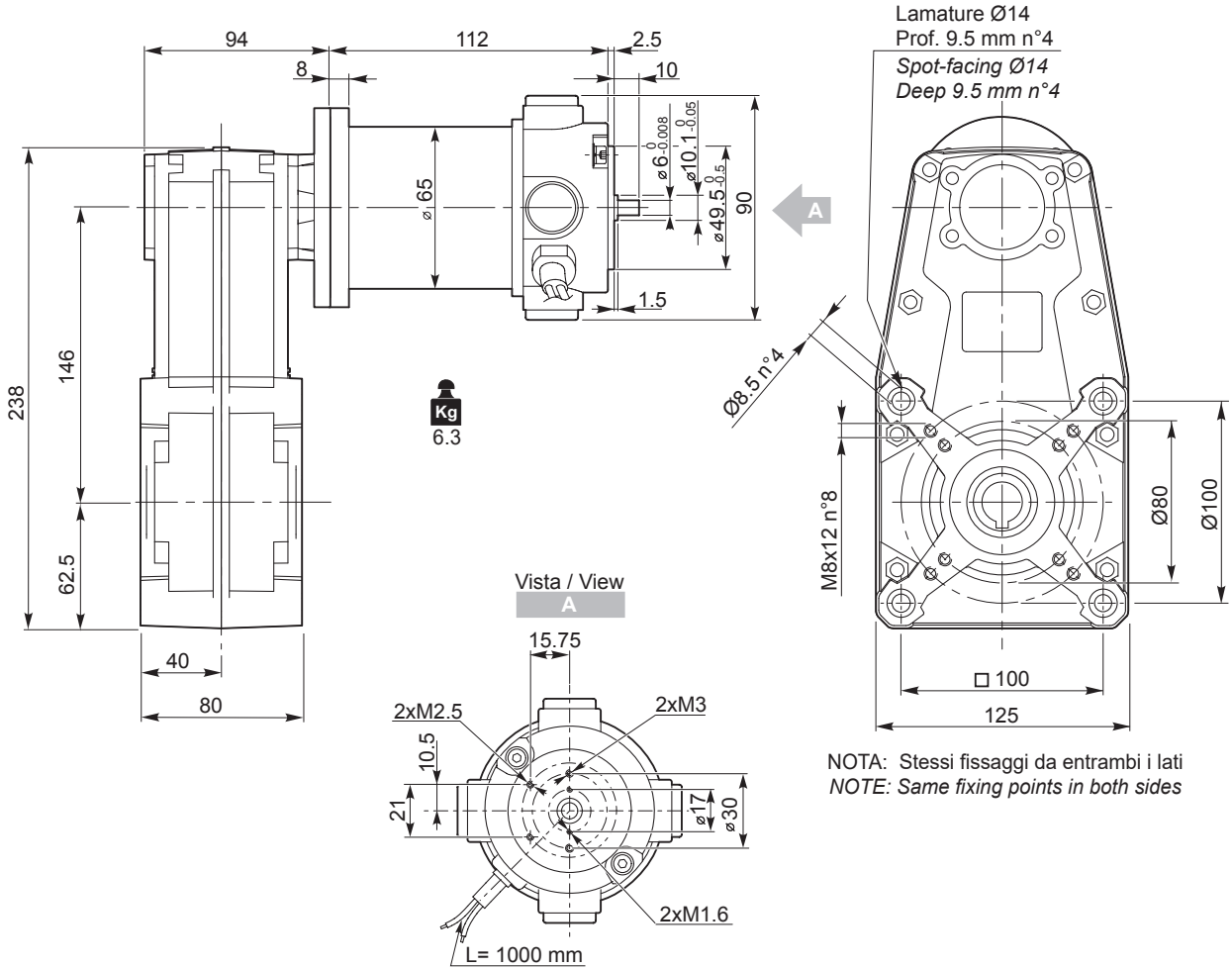

### O20

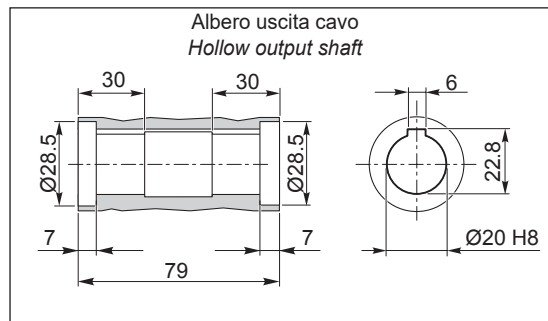

Freno / Brake

B9

Encoder

B9

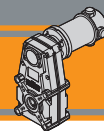

Dimensioni

Dimensions

**NDFT 180/146**

**NDFT 180/146...U**

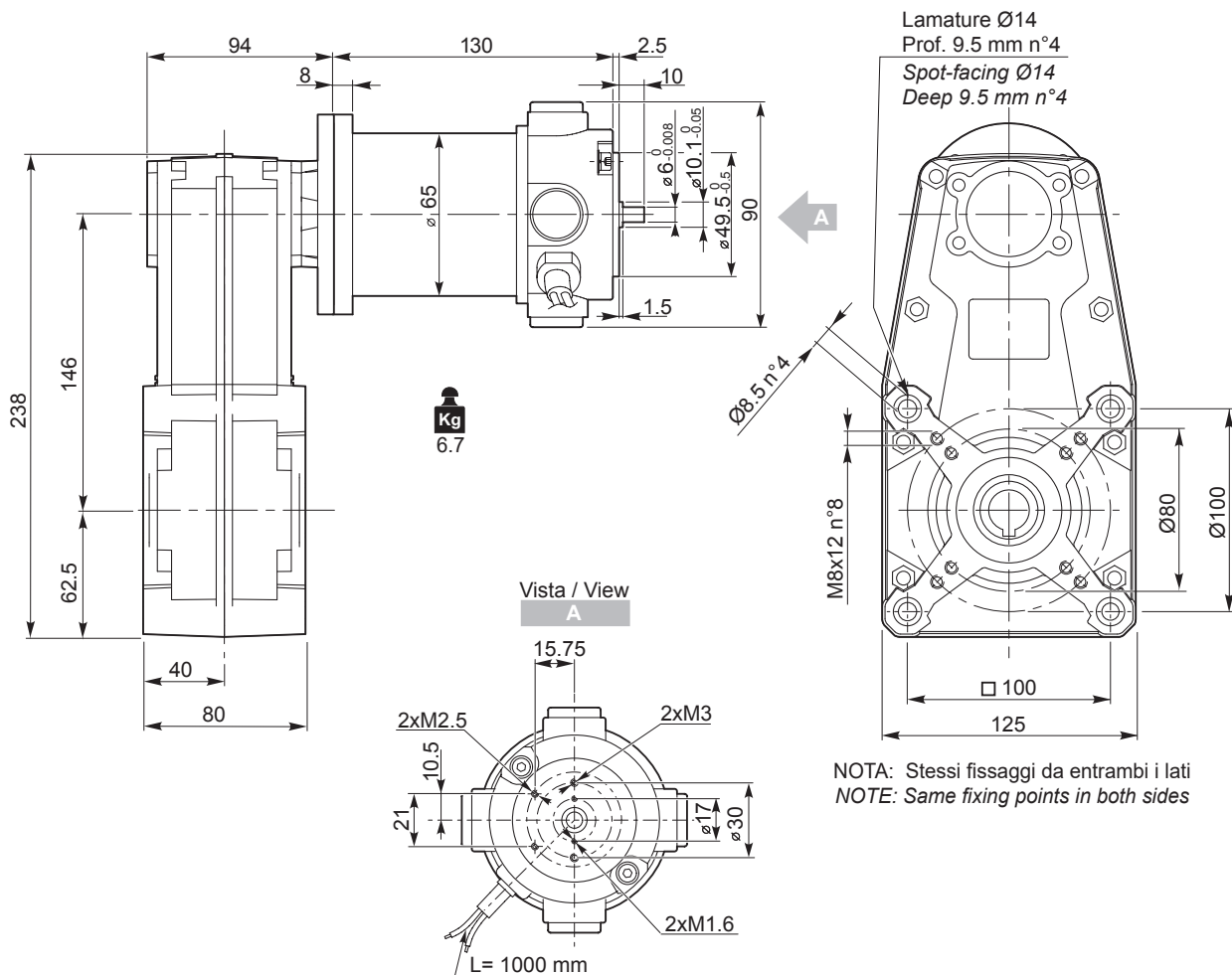

**NDFT**

**O20**

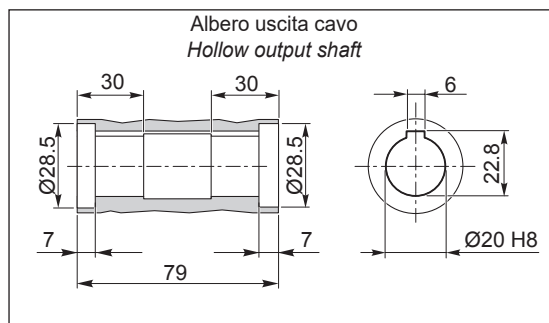

- Freno / Brake → B9
- Encoder → B9



**TRANSTECNO**<sup>®</sup>  
the modular gearmotor

**NDCM**

NDCM



Neodymium

Motoriduttori CC a vite senza fine  
**DC wormgearmotors**





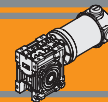

<b>Indice</b>	<b>Index</b>	Pag. Page
Caratteristiche tecniche	<i>Technical features</i>	<b>F2</b>
Designazione	<i>Classification</i>	<b>F2</b>
Simbologia	<i>Symbols</i>	<b>F2</b>
Lubrificazione	<i>Lubrication</i>	<b>F3</b>
Carichi radiali	<i>Radial loads</i>	<b>F3</b>
Dati di dentatura	<i>Toothing data</i>	<b>F4</b>
Rendimento	<i>Efficiency</i>	<b>F4</b>
Dati tecnici	<i>Technical data</i>	<b>F5</b>
Motori applicabili	<i>IEC Motor adapters</i>	<b>F5</b>
Dimensioni	<i>Dimensions</i>	<b>F6</b>
Opzioni	<i>Options</i>	<b>F10</b>
Accessori	<i>Accessories</i>	<b>F11</b>

Questa sezione annulla e sostituisce ogni precedente edizione o revisione. Qualora questa sezione non Vi sia giunta in distribuzione controllata, l'aggiornamento dei dati ivi contenuto non è assicurato. **In tal caso la versione più aggiornata è disponibile sul nostro sito internet [www.transtecno.com](http://www.transtecno.com)**

*This section replaces any previous edition and revision. If you obtained this catalogue other than through controlled distribution channels, the most up to date content is not guaranteed. **In this case the latest version is available on our web site [www.transtecno.com](http://www.transtecno.com)***

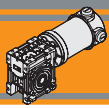

## Caratteristiche tecniche

## Technical features

Le caratteristiche principali dei motoriduttori CC a vite senza fine a magneti permanenti in neodimio NDCM sono:

The main features of NDCM neodymium permanent magnets DC wormgearmotors range are:

- Alimentazione in bassa tensione 12/24 Vcc
- Possibilità di montaggio encoder e freno
- Potenze motore disponibili da 160 a 250 W S2
- Magneti in Neodimio
- Carcasse dei riduttori a vite senza fine in pressofusione di alluminio
- Lubrificazione permanente con olio sintetico
- Low voltage power supply 12/24 Vdc
- Suitable for encoder and brake assembly
- Motor power ratings available from 160 to 250 W S2
- Neodymium magnets
- Die-cast aluminum housing on wormgearboxes
- Permanent synthetic oil long-life lubrication

## Designazione

## Classification

MOTORIDUTTORE / GEARMOTOR										
NDCM	120/030		U	10	SZDX	BRSX	90	240	VS	SC
Tipo Type	Grandezza Size		Versione Riduttore Gearbox Version	Rapporto Ratio	Albero di uscita Output shaft	Braccio di reazione Torque arm	Angolo Angle	Versione Motore Motor Version	Opzioni Options	Accessori Accessories
NDCM	120/026	180/026	U	Vedere tabella See tables	SZDX SZSX DZ	BRDX BRSX	0° 90° 180° 270°	120 240	VS**	SC Safety cover  WD Washdown cover
	120/026 (D11)	180/026 (D11)	F...							
	120/026 (D14)	180/026 (D14)				*				
	120/030	180/030								
	120/040	180/040								

Versione Riduttore  
Gearbox Version

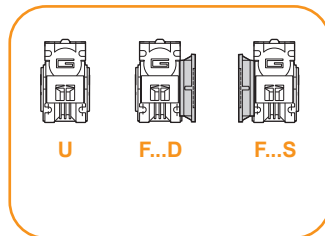

Albero di uscita  
Output shaft

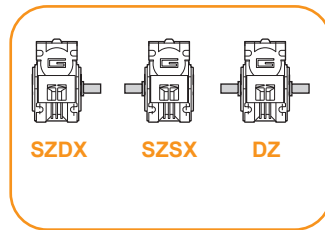

Braccio di reazione  
Torque arm \*

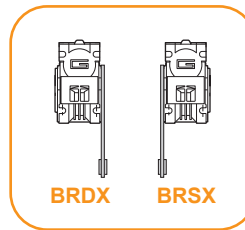

Angolo  
Angle

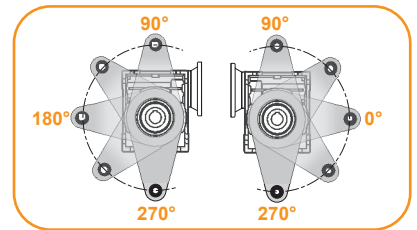

\* NOTA: il braccio di reazione viene fornito smontato.  
NOTE: the torque arm will be supplied not assembled.

\*\* NOTA: Vite sporgente costruita su richiesta  
NOTE: Extended input shaft built on request

## Simbologia

## Symbols

$n_1$	[min <sup>-1</sup> ]	Velocità in ingresso / Input speed	$R_d$	%	Rendimento dinamico / Dynamic efficiency
$n_2$	[min <sup>-1</sup> ]	Velocità in uscita / Output speed	$A_2$	[N]	Carico assiale ammissibile in uscita / Permitted output axial load
$i$		Rapporto di riduzione / Ratio	$R_s$	%	Rendimento statico / Static efficiency
$P_1$	[kW]	Potenza in entrata / Input power	$R_2$	[N]	Carico radiale ammissibile in uscita / Permitted output radial load
$M_2$	[Nm]	Coppia in uscita in funzione di $P_1$ / Output torque referred to $P_1$	$Z$		Numero di principi della vite / Worm starts
$sf$		Fattore di servizio / Service factor	$\beta$		Angolo d'elica / Helix angle



**Lubrificazione**

**Lubrication**

I riduttori a vite senza fine della serie CM sono lubrificati a vita con olio sintetico di viscosità 320 e possono essere installati in qualunque posizione di montaggio.

Permanent synthetic oil long-life lubrication allow to use CM wormgearbox range in all mounting position.

**Carichi radiali**

**Radial loads**

NDCM

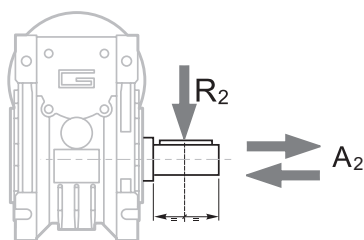

$$A_2 = R_2 \times 0.2$$

n <sub>2</sub> [min <sup>-1</sup> ]	R <sub>2</sub> [N]		
	CM026	CM030	CM040
600	271	457	857
400	310	523	981
300	342	576	1080
200	391	659	1236
150	479	726	1361
120	514	782	1466
100	547	831	1558
75	609	914	1715
60	610	985	1847
50	-	1047	1963
38	-	1147	2151
30	-	1241	2327

Quando il carico radiale risultante non è applicato sulla mezza-ria dell'albero occorre calcolare quello effettivo con la seguente formula:

When the resulting radial load is not applied on the centre line of the shaft it is necessary to calculate the effective load with the following formula:

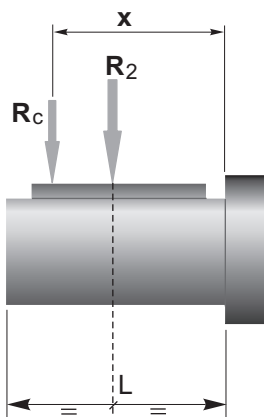

$$R_c = \frac{R_2 \cdot a}{(b+x)} \leq R_{2MAX}$$

$$R \leq R_c$$

a, b = valori riportati nella tabella  
a, b = values given in the table

	CM		
	026	030	040
a	56	65	84
b	43	50	64
R <sub>2MAX</sub>	610	1600	3000

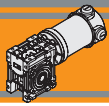

### Dati di dentatura

### Toothing data

	Dati della coppia vite-corona Worm wheel data	Rapporto / Ratio											
		5	7.5	10	15	20	25	30	40	50	60	80	100
CM026	Z	6	4	3	2	2		1	1	1	1		
	$\beta$	34° 35'	24° 41'	19° 1'	12° 57'	10° 30'		6° 33'	5° 17'	4° 26'	3° 49'		
CM030	Z	6	4	3	2	2	2	1	1	1	1	1	1
	$\beta$	27° 4'	24° 28'	18° 50'	12° 49'	10° 23'	8° 43'	6° 29'	5° 14'	4° 23'	3° 46'	2° 57'	2° 25'
CM040	Z	6	4	3	2	2	2	1	1	1	1	1	1
	$\beta$	34° 19'	24° 28'	18° 50'	12° 49'	10° 23'	8° 43'	6° 29'	5° 14'	4° 23'	3° 46'	2° 57'	2° 25'

### Rendimento

### Efficiency

	$n_1$ [min <sup>-1</sup> ]	Rendimento Efficiency	Rapporto / Ratio											
			5	7.5	10	15	20	25	30	40	50	60	80	100
CM026	2800	Rd	89	87	85	83	80		73	68	64	60		
	1400		87	84	83	78	74		66	61	57	53		
	900		84	83	80	75	71		61	57	52	48		
		Rs	72	71	68	61	56		46	41	36	34		
CM030	2800	Rd	89	88	86	84	81	78	74	70	65	62	57	52
	1400		86	85	84	79	75	72	67	62	58	55	48	43
	900		84	83	81	75	71	68	62	58	53	49	43	39
		Rs	72	67	63	55	50	43	39	35	31	27	23	21
CM040	2800	Rd	90	89	87	84	83	80	77	73	69	66	60	56
	1400		88	86	84	81	78	74	70	65	60	58	52	46
	900		86	84	82	77	74	70	66	60	57	53	46	41
		Rs	74	71	67	60	55	51	45	40	36	32	28	24



**Rendimento teorico del riduttore dopo il rodaggio**  
*Theoretical efficiency of the gearbox after the first running period*

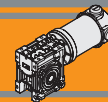

Dati tecnici per servizio S2

Technical data for S2 duty

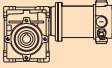
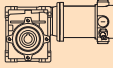
P <sub>1</sub> [W]	n <sub>2</sub> [min <sup>-1</sup> ]	M <sub>2</sub> [Nm]	sf	i		Versione motore Motor version	P <sub>1</sub> [W]	n <sub>2</sub> [min <sup>-1</sup> ]	M <sub>2</sub> [Nm]	sf	i		Versione motore Motor version
<b>160</b>							<b>250</b>						
(3000 min <sup>-1</sup> )	600	2	4.4	5	120/026	120/240	(3000 min <sup>-1</sup> )	600	4	2.8	5	180/026	120/240
	400	3	3.3	7.5	120/026			400	5	2.1	7.5	180/026	
	300	4	2.5	10	120/026			300	7	1.6	10	180/026	
	200	6	1.7	15	120/026			200	10	1.1	15	180/026	
	150	8	1.3	20	120/026			150	13	0.9	20	180/026	
	100	11	1.1	30	120/026			100	17	0.7	30	180/026	
	75	14	0.8	40	120/026			75	16	0.7	40	180/026	
	60	14	0.7	50	120/026			60	14	0.7	50	180/026	
	50	13	0.7	60	120/026			50	13	0.7	60	180/026	
	600	2	5.7	5	120/030	120/240		600	4	3.7	5	180/030	120/240
	400	3	4.5	7.5	120/030			400	5	2.9	7.5	180/030	
	300	4	3.7	10	120/030			300	7	2.3	10	180/030	
	200	6	2.5	15	120/030			200	10	1.6	15	180/030	
	150	8	1.7	20	120/030			150	13	1.1	20	180/030	
	120	10	1.5	25	120/030			120	16	1.0	25	180/030	
	100	11	1.6	30	120/030			100	18	1.0	30	180/030	
	75	14	1.1	40	120/030			75	22	0.7	40	180/030	
	60	17	0.9	50	120/030			60	21	0.7	50	180/030	
	50	20	0.7	60	120/030			50	20	0.7	60	180/030	
	38	17	0.7	80	120/030			38	17	0.7	80	180/030	
	30	16	0.7	100	120/030			30	16	0.7	100	180/030	
	150	8	3.7	20	120/040	120/240		600	4	8.1	5	180/040	120/240
	120	10	2.7	25	120/040			400	5	5.8	7.5	180/040	
	100	12	3.2	30	120/040			300	7	4.8	10	180/040	
	75	15	2.3	40	120/040			200	10	3.5	15	180/040	
	60	18	1.8	50	120/040			150	13	2.3	20	180/040	
	50	20	1.4	60	120/040			120	16	1.8	25	180/040	
	38	24	1.1	80	120/040			100	18	2.1	30	180/040	
	30	29	0.8	100	120/040			75	23	1.5	40	180/040	
								60	27	1.2	50	180/040	
								50	32	0.9	60	180/040	
								38	38	0.7	80	180/040	
								30	34	0.7	100	180/040	

N.B.  
Verificare sempre che la coppia M<sub>2</sub> utilizzata non ecceda il valore indicato nelle caselle in grigio

N.B.  
Please check that the output torque M<sub>2</sub> does not exceed the value in the grey areas

**NOTA:** per servizio continuo o altamente intermittente, contattare il servizio tecnico

**NOTE:** for continuous or highly intermittent duty, please contact our technical service

Motori applicabili

IEC Motor adapters

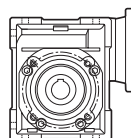
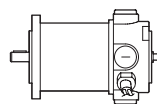

		ND	
		120.120 120.240	180.120 180.240
CM	026	5 - 60	5 - 60
	030	5 - 100	5 - 100
	040	5 - 100	5 - 100

5-100

Rapporti di riduzione i  
Ratio i

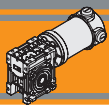

## Dimensioni

## Dimensions

### NDCM120/026 U

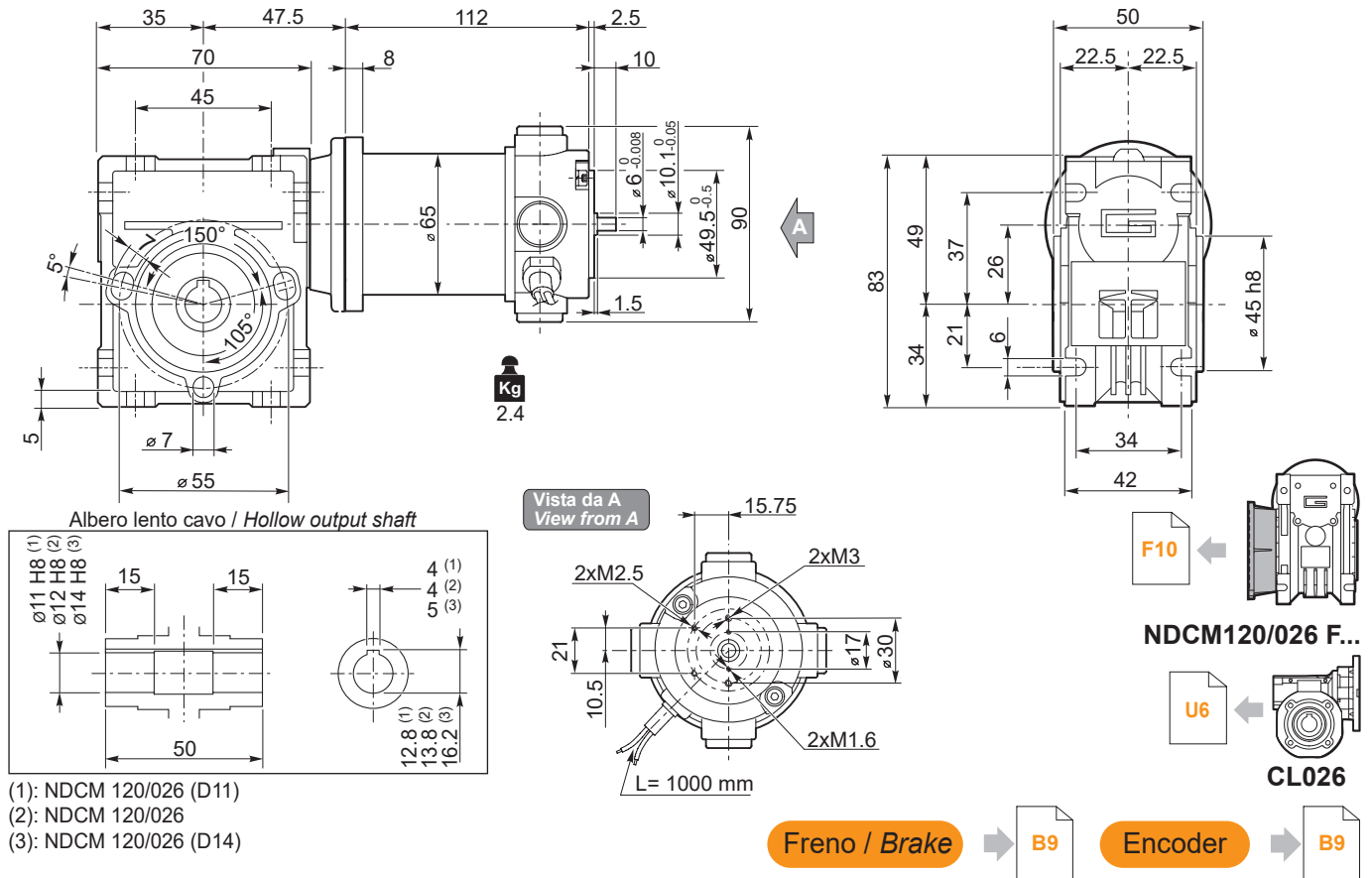

### NDCM120/030 U

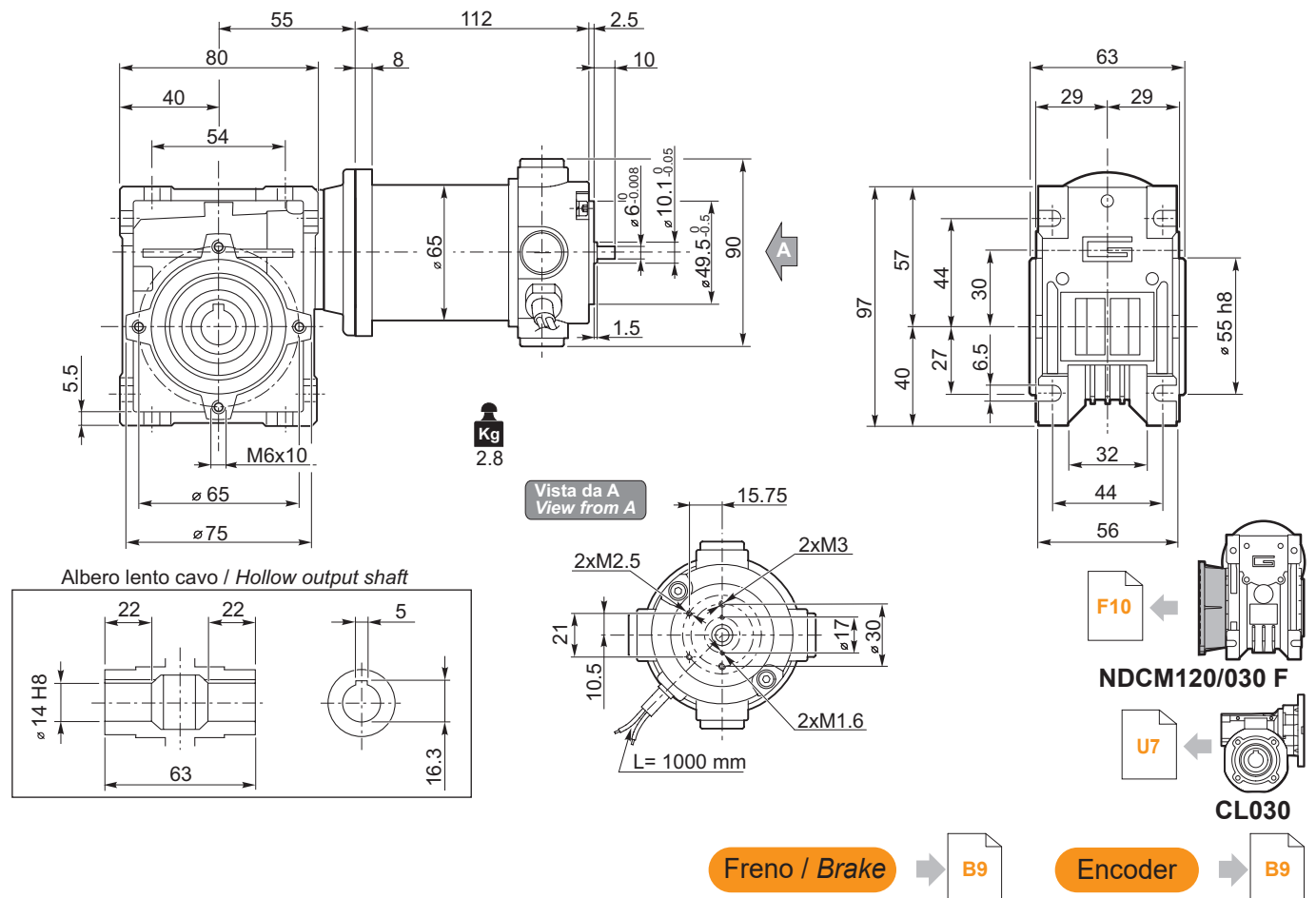

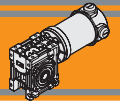

Dimensioni

Dimensions

**NDCM120/040 U**

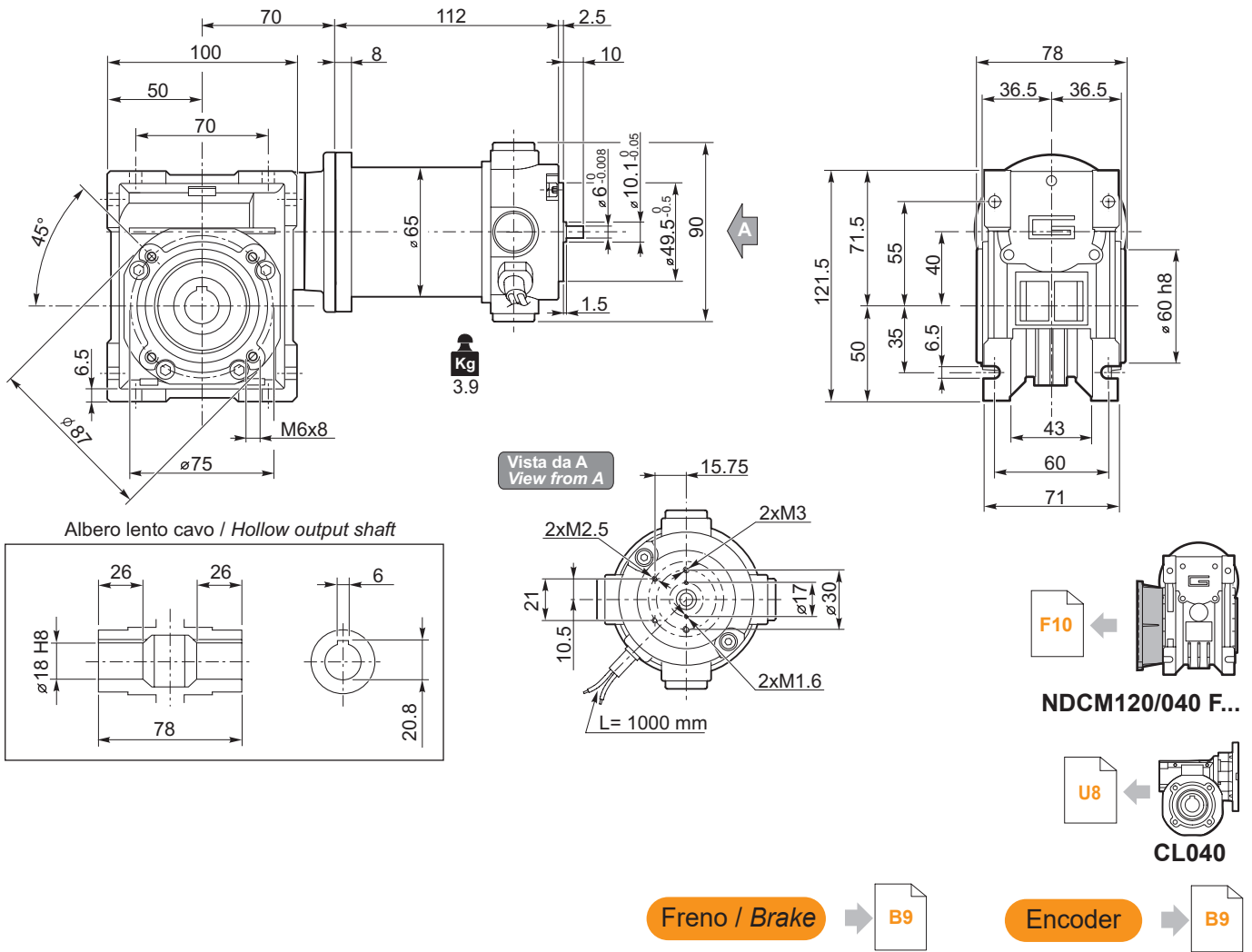

NDCM

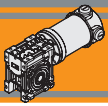

## Dimensioni

## Dimensions

### NDCM180/026 U

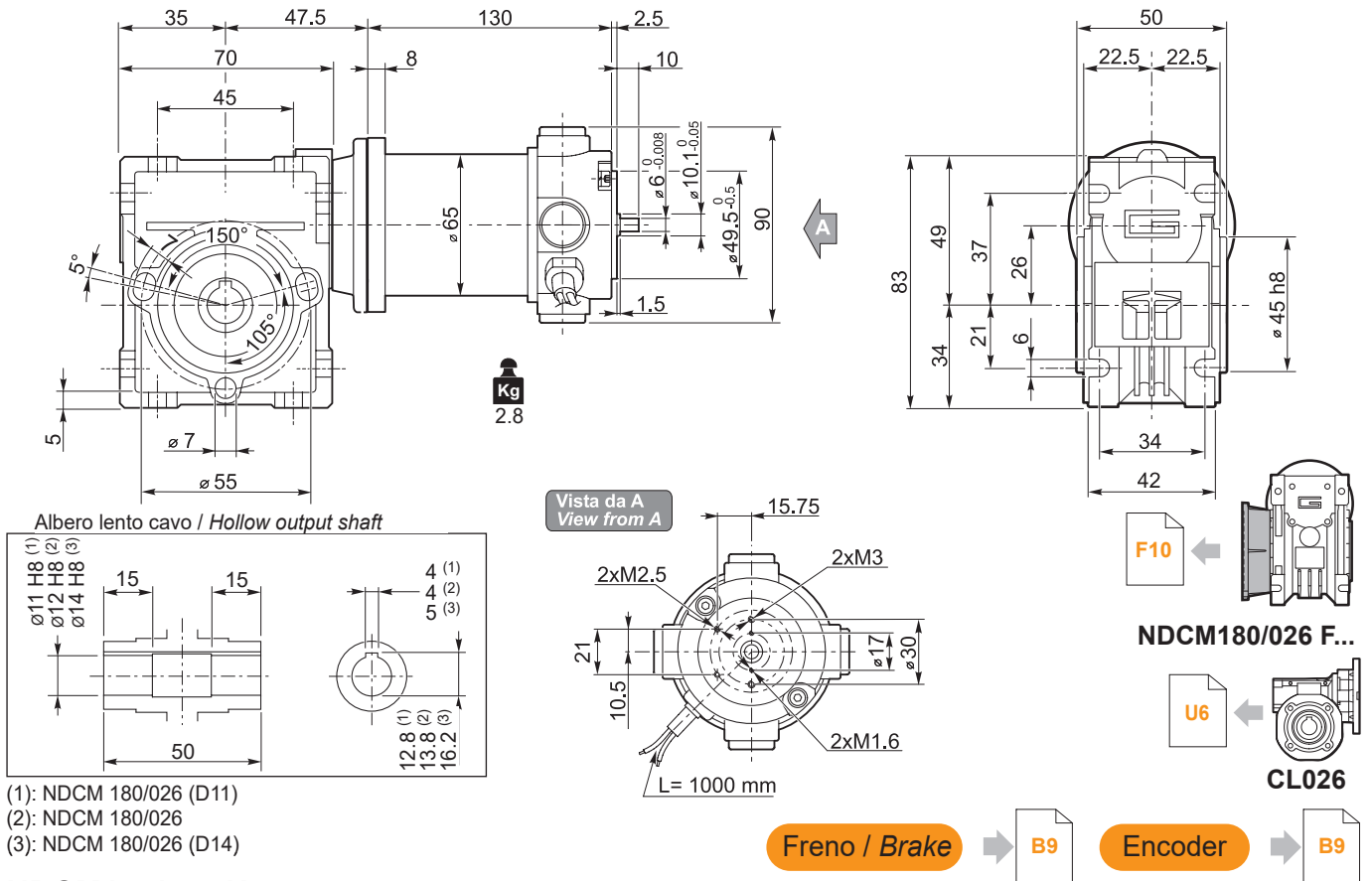

### NDCM180/030 U

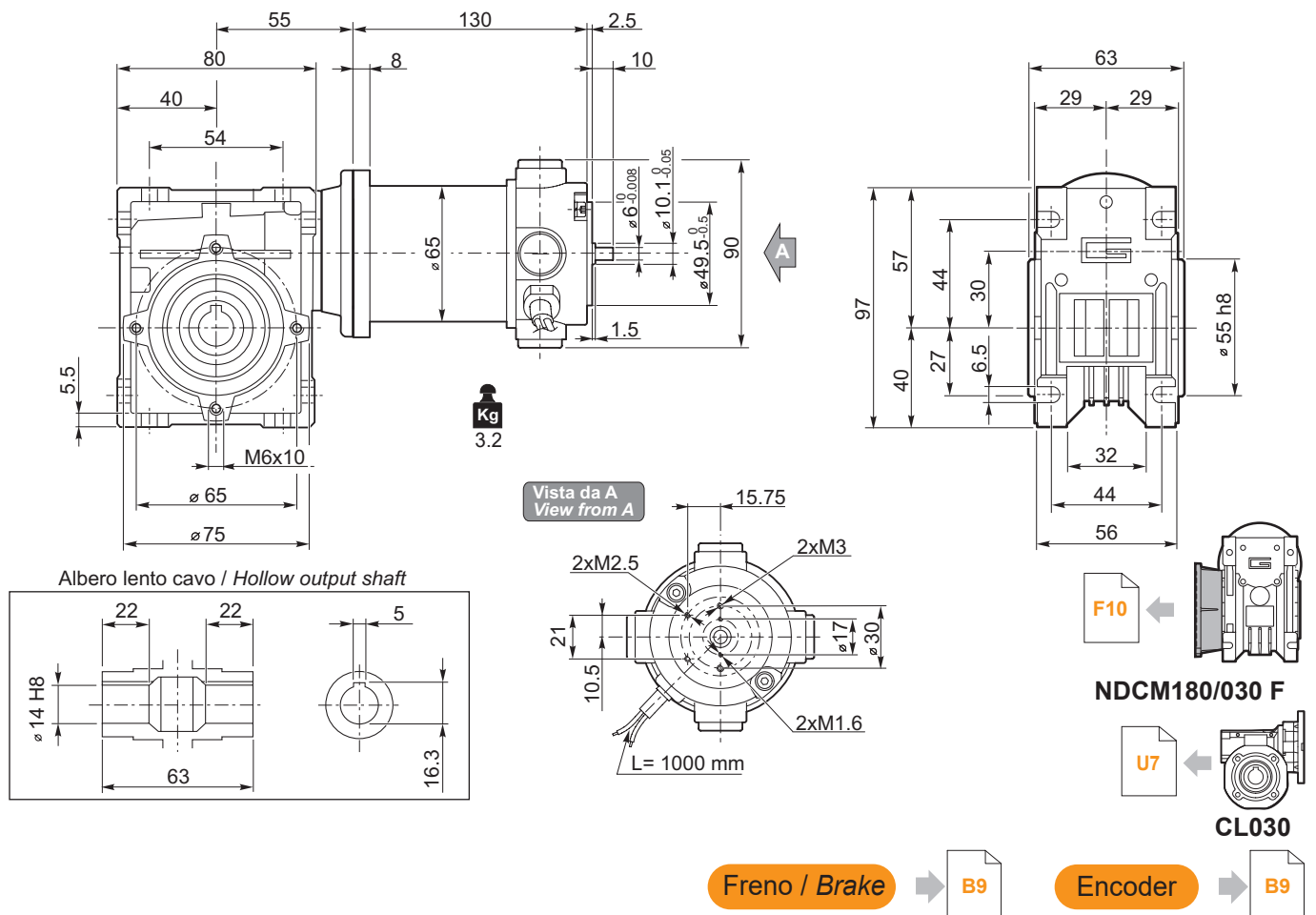



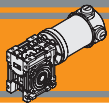

### Dimensioni

### Dimensions

#### NDCM.../... F... Flange uscita / Output flanges

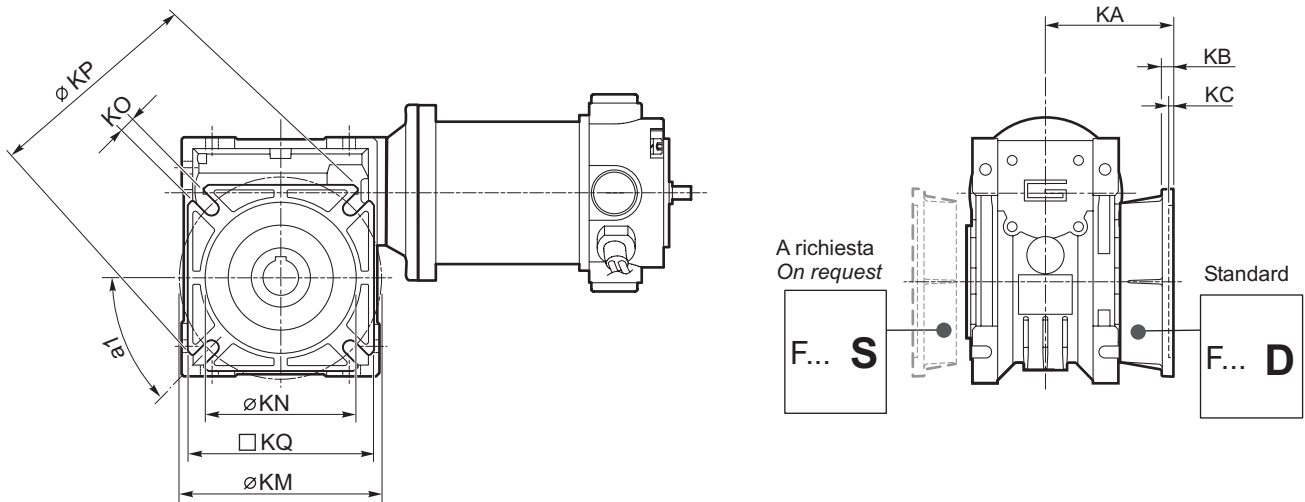

	CM..F							CM..F28							CM..F30										
	a1	KA	KB	KC	KM	KN <sub>H8</sub>	KO	KP	KQ	KA	KB	KC	KM	KN <sub>H8</sub>	KO	KP	KQ	KA	KB	KC	KM	KN <sub>H8</sub>	KO	KP	KQ
<b>026 (D11)</b>	45°	45	6	4.5	55-69	40	6.5(n.4)	75	70	44	6.5	5	56-64	40	6.5	70	60	48	6.5	5	68	50	6.5	80	70
<b>026</b>																									
<b>026 (D14)</b>																									

	CM..F							CM..FB							CM..FL										
	a1	KA	KB	KC	KM	KN <sub>H8</sub>	KO	KP	KQ	KA	KB	KC	KM	KN <sub>H8</sub>	KO	KP	KQ	KA	KB	KC	KM	KN <sub>H8</sub>	KO	KP	KQ
<b>030</b>	45°	54.5	6	4	68	50	6.5(n.4)	80	70	—	—	—	—	—	—	—	—	—	—	—	—	—	—	—	—
<b>040</b>	45°	67	7.5	4.5	80-95	60	9(n.4)	110	95	80	8.5	5	115-125	95	9.5(n.4)	140	112	97	7.5	4.5	80-95	60	10(n.4)	110	95

### Opzioni

### Options

#### VS - Vite sporgente / Extended input shaft

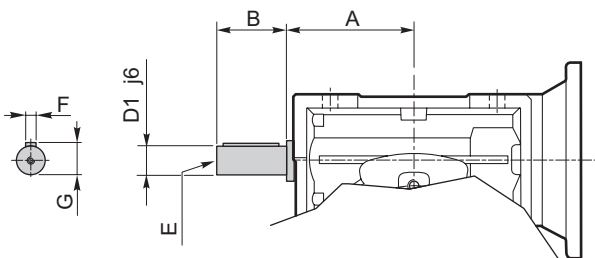

	A	B	D <sub>1</sub> j6	E	F	G
<b>CM 030</b>	45	20	9	M4	3	10.2
<b>CM 040</b>	53	23	11	M5	4	12.5

Costruito su richiesta  
Built on request

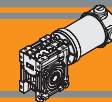

Accessori

Accessories

SC - Safety cover

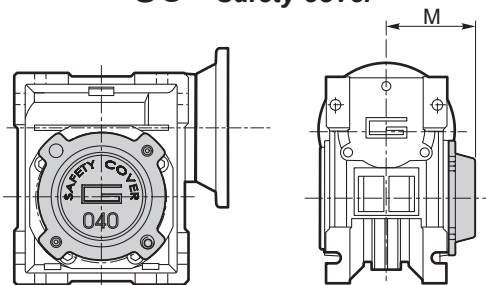

	M
CM 030	47
CM 040	54.5

WD - Washdown cover

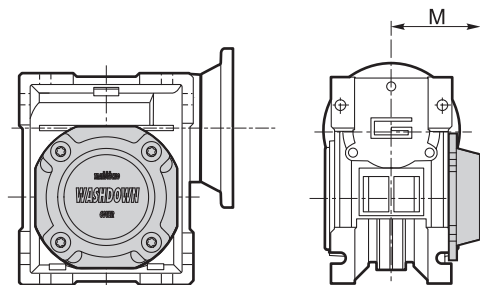

CM	M
030	48
040	55.5

NDCM

Albero lento

Output shaft

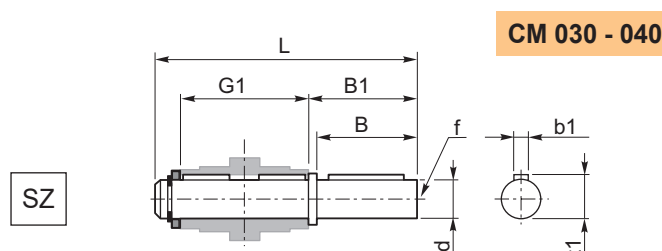
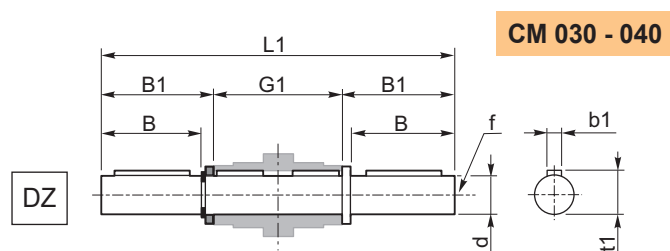

	d h7	B	B1	G1	L	L1	f	b1	t1
CM 030	14	30	32.5	63	102	128	M6	5	16
CM 040	18	40	43	78	128	164	M6	6	20.5

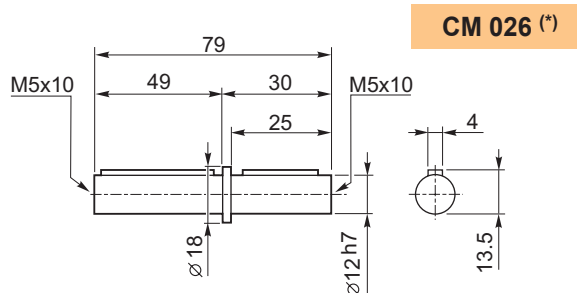

(\*)  
Nota: disponibile solo per cavo uscita Ø12  
Note: available for output hollow shaft Ø12 only

Braccio di reazione

Torque arm

	K1	G	KG	KH	R
CM 030	85	14	23	8	15
CM 040	100	14	31	10	18

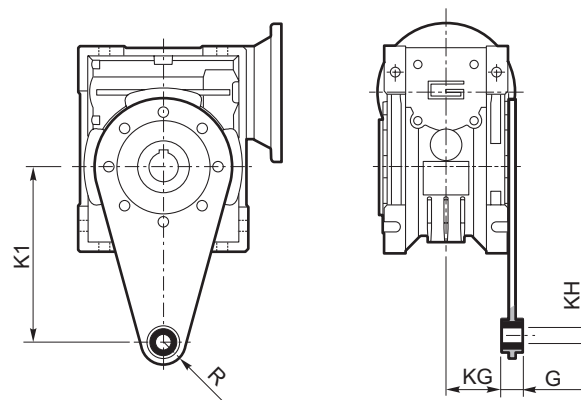





Neodymium

## Motoriduttori CC a vite senza fine con precoppia DC pre stage wormgearmotors

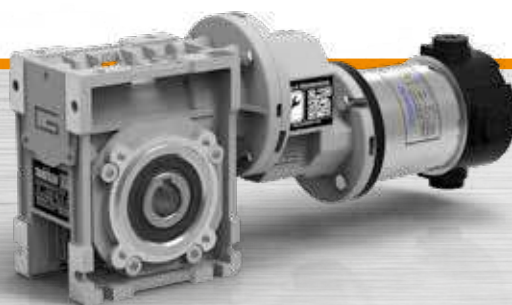



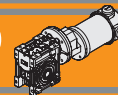

<b>Indice</b>	<b>Index</b>	Pag. Page
Caratteristiche tecniche	<i>Technical features</i>	<b>G2</b>
Designazione	<i>Classification</i>	<b>G2</b>
Simbologia	<i>Symbols</i>	<b>G3</b>
Lubrificazione	<i>Lubrication</i>	<b>G3</b>
Carichi radiali	<i>Radial loads</i>	<b>G3</b>
Dati tecnici	<i>Technical data</i>	<b>G4</b>
Motori applicabili	<i>IEC Motor adapters</i>	<b>G4</b>
Dimensioni	<i>Dimensions</i>	<b>G5</b>
Opzioni	<i>Options</i>	<b>G7</b>
Accessori	<i>Accessories</i>	<b>G8</b>

Questa sezione annulla e sostituisce ogni precedente edizione o revisione. Qualora questa sezione non Vi sia giunta in distribuzione controllata, l'aggiornamento dei dati ivi contenuto non è assicurato. **In tal caso la versione più aggiornata è disponibile sul nostro sito internet [www.transtecno.com](http://www.transtecno.com)**

*This section replaces any previous edition and revision. If you obtained this catalogue other than through controlled distribution channels, the most up to date content is not guaranteed. In this case the latest version is available on our web site [www.transtecno.com](http://www.transtecno.com)*

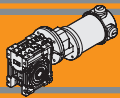

### Caratteristiche tecniche

### Technical features

Le caratteristiche principali dei motoriduttori CC a vite senza fine con precoppia a magneti permanenti in neodimio NDCMP sono:

The main features of NDCMP neodymium permanent magnets DC pre stage wormgearmotors range are:

- Alimentazione in bassa tensione 12/24 Vcc
- Possibilità di montaggio encoder e freno
- Potenze motore disponibili da 160 a 250 W S2
- Magneti in Neodimio
- Sia le carcasse dei riduttori a vite senza fine che delle precoppie sono in pressofusione di alluminio
- Lubrificazione permanente con olio sintetico.

- Low voltage power supply 12/24 Vdc
- Suitable for encoder and brake assembly
- Motor power ratings available from 160 to 250 W S2
- Neodymium magnets
- Die-cast aluminum housing on pre-stage and wormgearboxes
- Permanent synthetic oil long-life lubrication.

### Designazione

### Classification

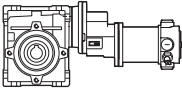
MOTORIDUTTORE / GEARMOTOR											
NDCMP	120/056/030		U	90	SZDX	BRSX	90	P4	240	VS	SC
Tipo Type	Grandezza Size		Versione Riduttore Gearbox Version	Rapporto Ratio	Albero di uscita Output shaft	Braccio di reazione Torque arm	Angolo Angle	Pos. di montaggio precoppia Pre stage mounting position	Versione Motore Motor Version	Opzioni Options	Accessori Accessories
	120/056/030	180/056/030	U	Vedere tabella  See tables	SZDX SZSX DZ	BRDX BR SX	0° 90° 180° 270°	P1 P2 P3 (standard) P4	120 240	VS**	SC Safety cover  WD Washdown cover
	120/056/040	180/056/040	FD FS FLD FLS FBD FBS								

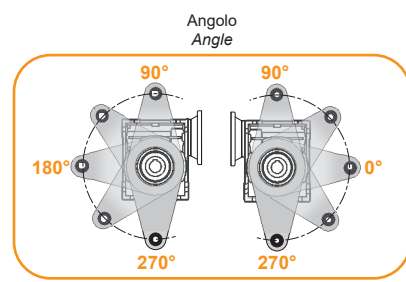
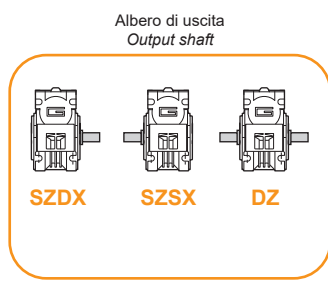
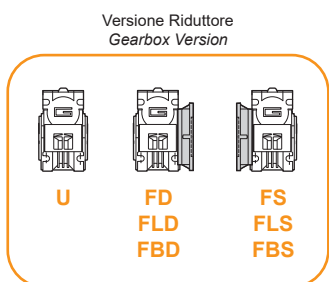
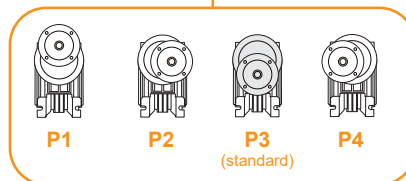

\* NOTA: il braccio di reazione viene fornito smontato.  
NOTE: the torque arm will be supplied not assembled.

\*\* NOTA: Vite sporgente costruita su richiesta  
NOTE: Extended input shaft built on request

**Simbologia**

**Symbols**

$n_1$ [min <sup>-1</sup> ]	Velocità in ingresso / <i>Input speed</i>	$M_2$ [Nm]	Coppia in uscita in funzione di $P_1$ / <i>Output torque referred to <math>P_1</math></i>
$n_2$ [min <sup>-1</sup> ]	Velocità in uscita / <i>Output speed</i>	sf	Fattore di servizio / <i>Service factor</i>
i	Rapporto di riduzione / <i>Ratio</i>	$R_2$ [N]	Carico radiale ammissibile in uscita / <i>Permitted output radial load</i>
$P_1$ [kW]	Potenza in entrata / <i>Input power</i>	$A_2$ N]	Carico assiale ammissibile in uscita / <i>Permitted output axial load</i>

**Lubrificazione**

**Lubrication**

I riduttori a vite senza fine con precoppia della serie CMP sono lubrificati a vita con olio sintetico di viscosità 320 e possono essere installati in qualunque posizione di montaggio.

*Permanent synthetic oil long-life lubrication allow to use CMP range in all mounting position.*

**Carichi radiali**

**Radial loads**

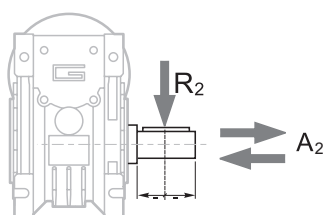

$n_2$ [min <sup>-1</sup> ]	$R_2$ [N]	
	CM030	CM040
35	1179	2210
28	1270	2381
23	1356	2542
18	1471	2759
14	1600	3000

Quando il carico radiale risultante non è applicato sulla mezzeria dell'albero occorre calcolare quello effettivo con la seguente formula:

*When the resulting radial load is not applied on the centre line of the shaft it is necessary to calculate the effective load with the following formula:*

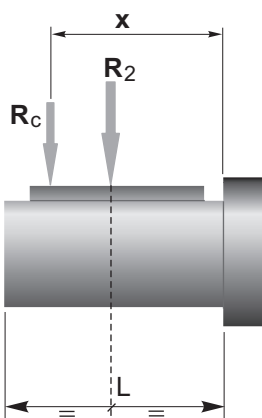

$$R_c = \frac{R_2 \cdot a}{(b + x)} \leq R_{2MAX}$$

$$R \leq R_c$$

a, b = valori riportati nella tabella  
a, b = values given in the table

	CMP	
	030	040
a	65	84
b	50	64
$R_{2MAX}$	1600	3000

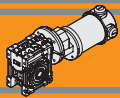

### Dati tecnici per servizio S2

### Technical data for S2 duty

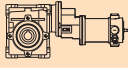
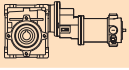
$P_1$ [W]	$n_2$ [min <sup>-1</sup> ]	$M_2$ [Nm]	sf	i		Versione motore Motor version	$P_1$ [W]	$n_2$ [min <sup>-1</sup> ]	$M_2$ [Nm]	sf	i		Versione motore Motor version
<b>160</b>							<b>250</b>						
(3000 min <sup>-1</sup> )	<b>50</b>	21	1.0	60	<b>120/056/030</b>	120/240	(3000 min <sup>-1</sup> )	50	31	0.7	60	<b>180/056/030</b>	180/240
	<b>40</b>	25	0.9	75			40	31	0.7	75			
	<b>33</b>	28	1.0	90			33	39	0.7	90			
	<b>25</b>	35	0.7	120			25	33	0.7	120			
	<b>20</b>	31	0.7	150			20	31	0.7	150			
	<b>50</b>	22	2.0	60	<b>120/056/040</b>	120/240		50	35	1.3	60	<b>180/056/040</b>	180/240
	<b>40</b>	26	1.7	75			40	41	1.1	75			
	<b>33</b>	30	1.9	90			33	46	1.2	90			
	<b>25</b>	36	1.3	120			25	56	0.9	120			
	<b>20</b>	43	1.1	150			20	66	0.7	150			
	<b>17</b>	48	0.9	180			17	61	0.7	180			
	<b>13</b>	55	0.7	240			13	57	0.7	240			
	<b>10</b>	51	0.7	300			10	51	0.7	300			

N.B.  
Verificare sempre che la coppia  $M_2$  utilizzata non ecceda il valore indicato nelle caselle in grigio

N.B.  
Please check that the output torque  $M_2$  does not exceed the value in the grey areas

**NOTA:** per servizio continuo o altamente intermittente, contattare il servizio tecnico

**NOTE:** for continuous or highly intermittent duty, please contact our technical service

### Motori applicabili

### IEC Motor adapters

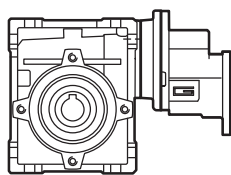
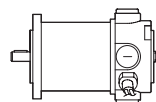

		ND	
		120.120 120.240	180.120 180.240
CMP	056/030	150	300
	056/040	150	300

150

Rapporto di riduzione massimo  $i_{max}$   
Maximum ratio  $i_{max}$

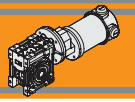

**Dimensioni**

**Dimensions**

**NDCMP120/056/030 U**

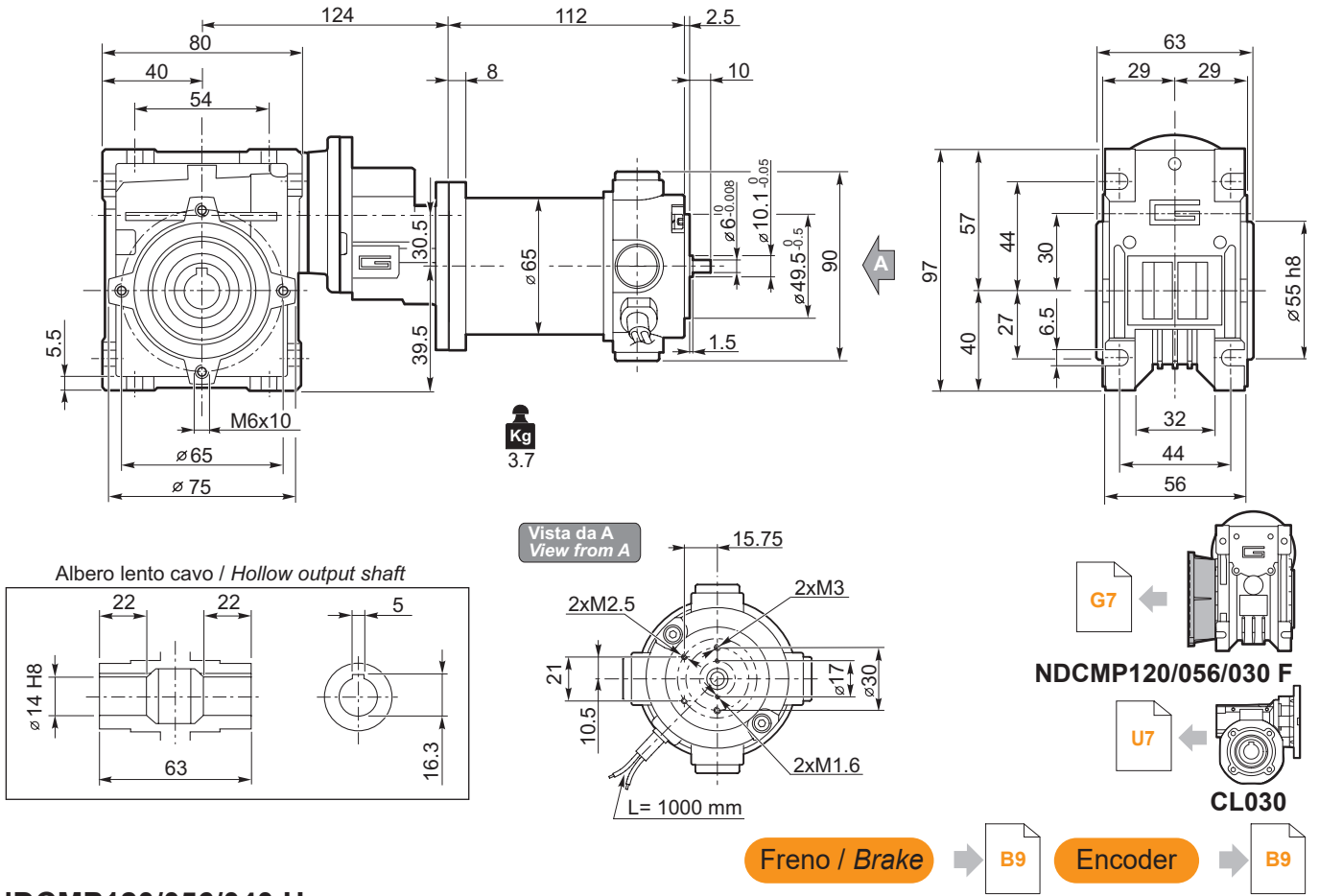

**NDCMP120/056/040 U**

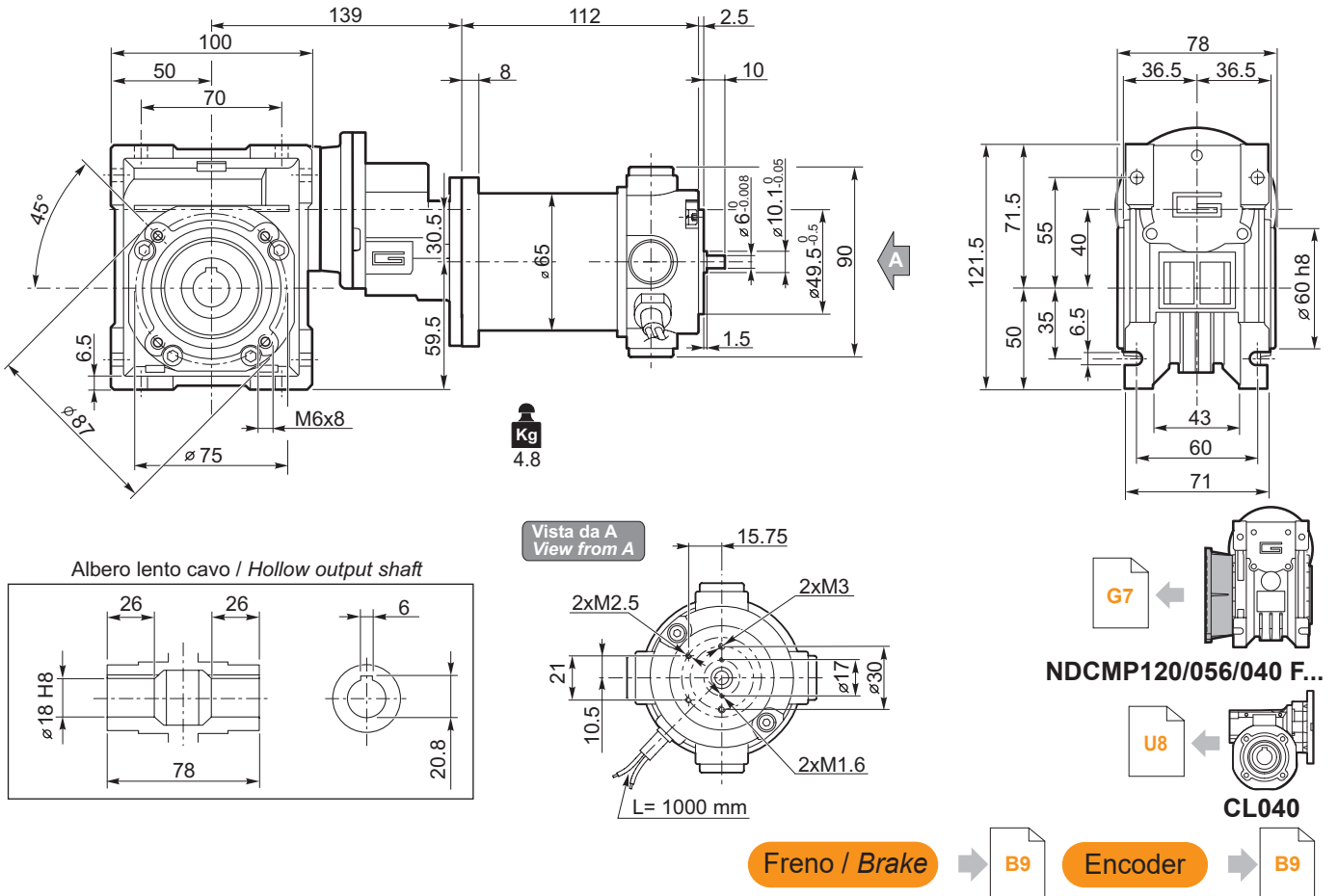

**NDCMP**

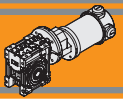

### Dimensioni

### Dimensions

#### NDCMP180/056/030 U

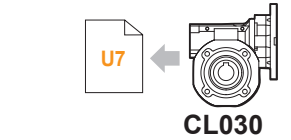
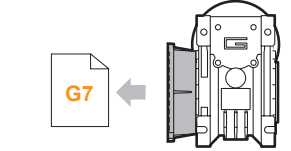
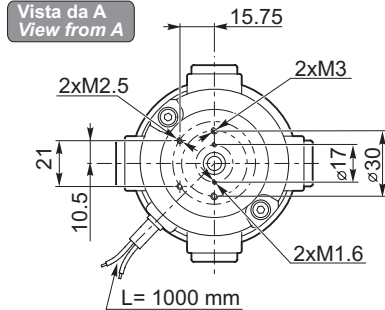
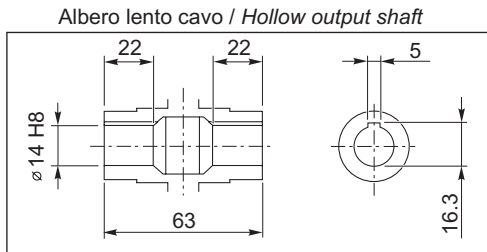
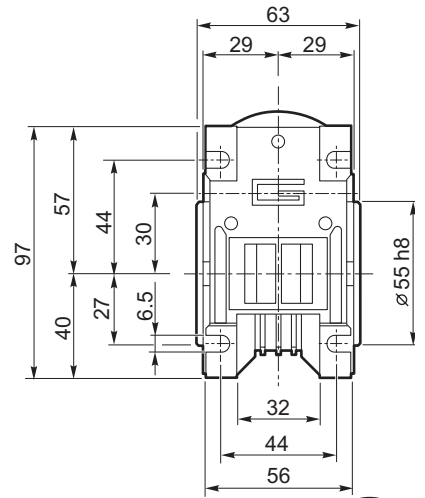
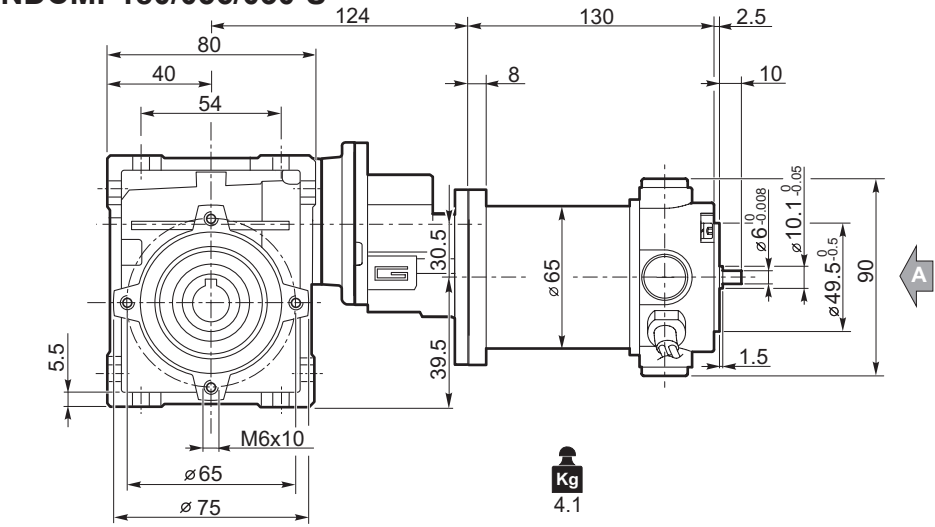

Freno / Brake → B9 Encoder → B9

#### NDCMP180/056/040 U

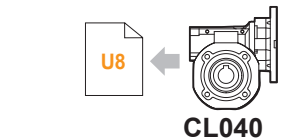
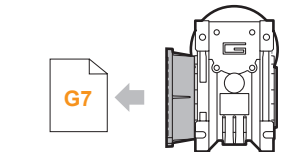
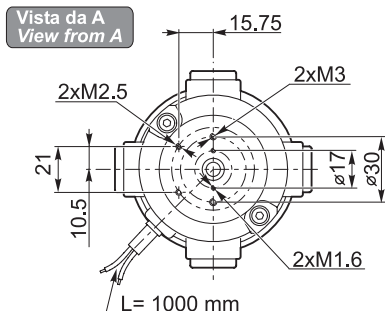
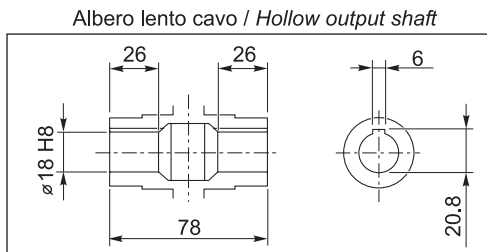
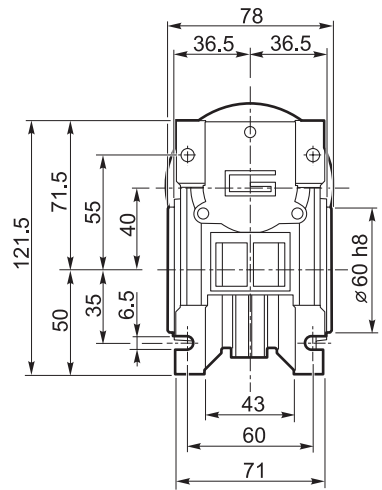
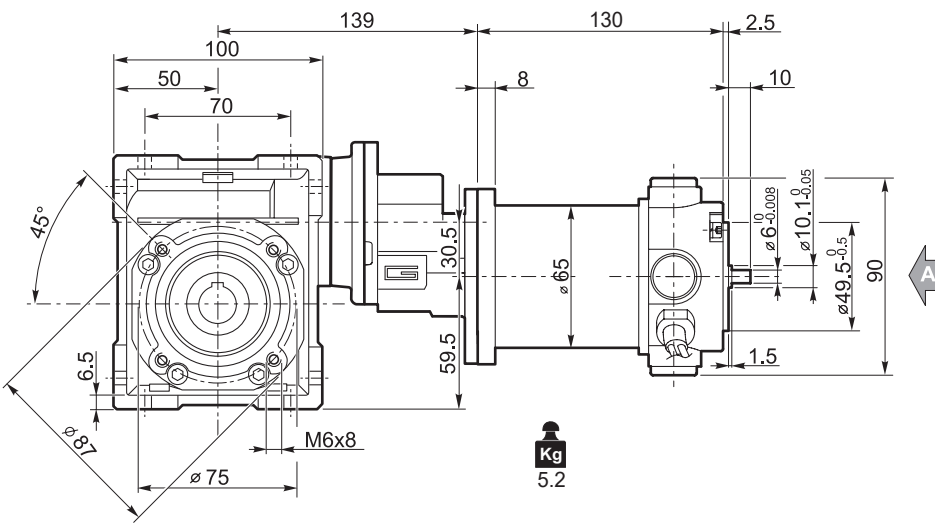

Freno / Brake → B9 Encoder → B9

**Dimensioni**

**Dimensions**

**NDCMP.../... F... Flange uscita / Output flanges**

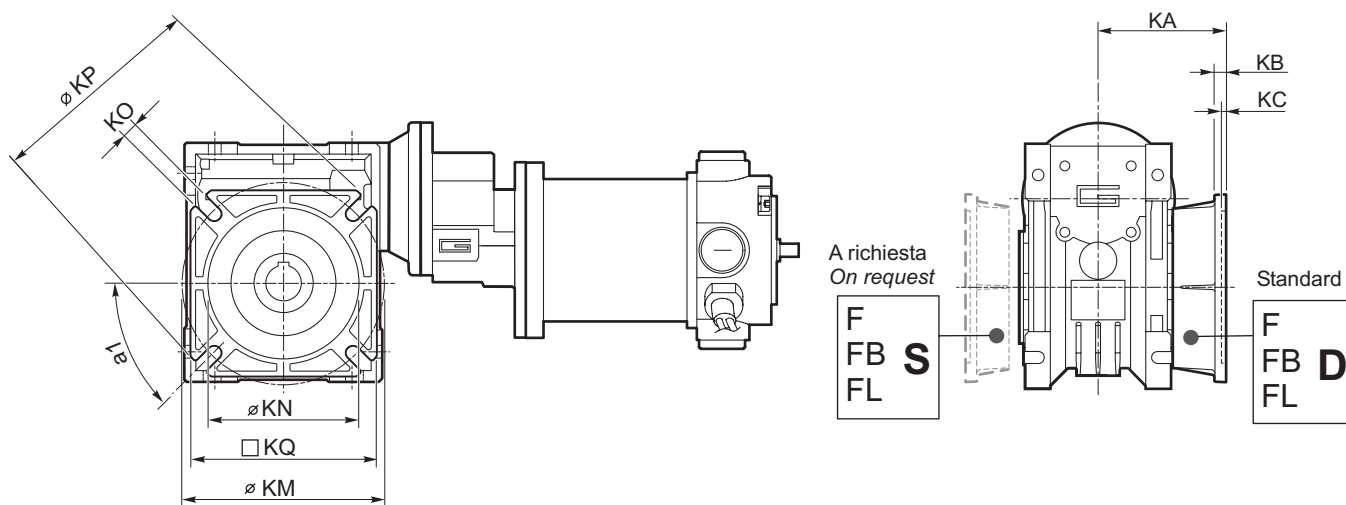

NDCMP

CMP	CMP.F									CMP.FB						CMP.FL									
	a1	KA	KB	KC	KM	KN <sub>H8</sub>	KO	KP	KQ	KA	KB	KC	KM	KN <sub>H8</sub>	KO	KP	KQ	KA	KB	KC	KM	KN <sub>H8</sub>	KO	KP	KQ
056/030	45°	54.5	6	4	68	50	6.5(n.4)	80	70	—	—	—	—	—	—	—	—	—	—	—	—	—	—	—	—
056/040	45°	67	7.5	4.5	80-95	60	9(n.4)	110	95	80	8.5	5	115-125	95	9.5(n.4)	140	112	97	7.5	4.5	80-95	60	10(n.4)	110	95

**Opzioni**

**Options**

**VS - Vite sporgente / Extended input shaft**

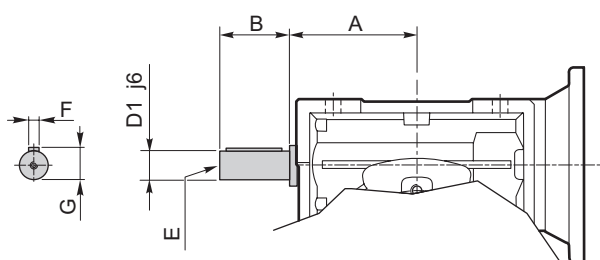

CMP	A	B	D <sub>1</sub> j <sub>6</sub>	E	F	G
056/030	45	20	9	M4	3	10.2
056/040	53	23	11	M5	4	12.5

 Costruito su richiesta  
Built on request

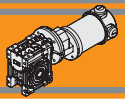

### Accessori

### Accessories

#### SC - Safety cover

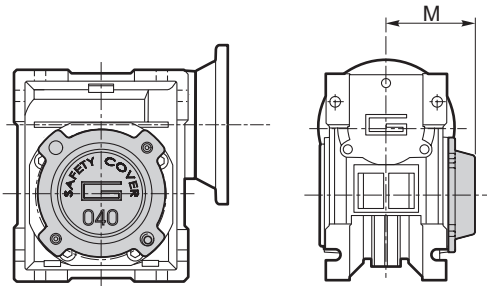

CMP	M
056/030	47
056/040	54.5

#### WD - Washdown cover

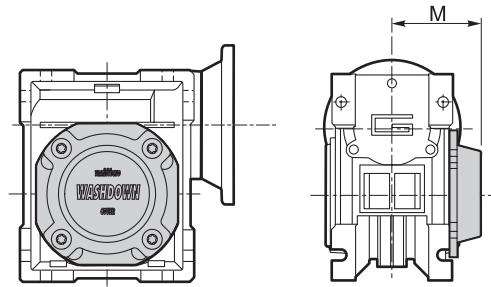

CMP	M
056/030	48
056/040	55.5

#### Albero lento semplice e doppio

#### Single and double output shaft

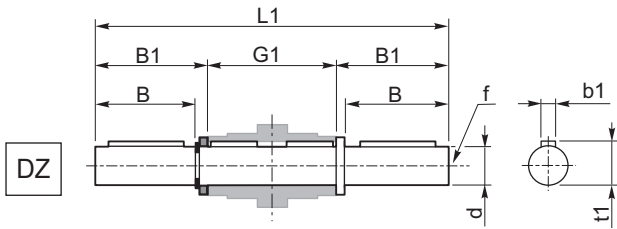

SZ

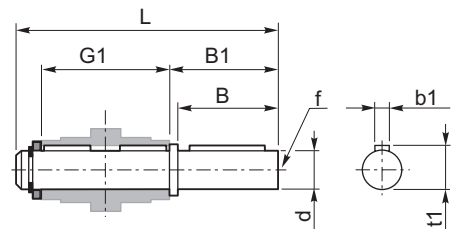

CMP	d h7	B	B1	G1	L	L1	f	b1	t1
056/030	14	30	32.5	63	102	128	M6	5	16
056/040	18	40	43	78	128	164	M6	6	20.5

#### Braccio di reazione

#### Torque arm

CMP	K1	G	KG	KH	R
056/030	85	14	23	8	15
056/040	100	14	31	10	18

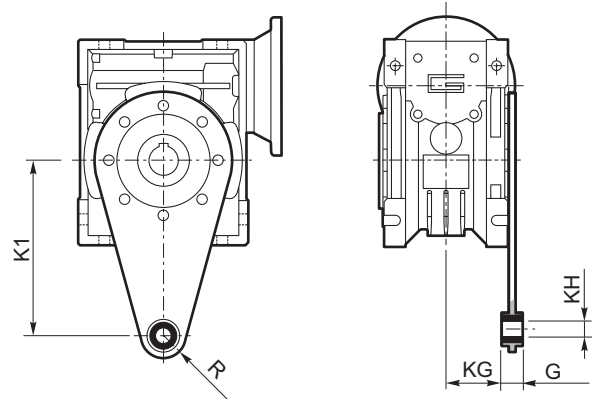



Neodymium

Motoriduttori CC  
ad ingranaggi cilindrici monostadio  
**Single stage helical gearmotors**





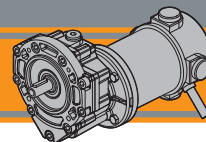

<b>Indice</b>	<b>Index</b>	Pag. Page
Caratteristiche tecniche	<i>Technical features</i>	<b>H2</b>
Designazione	<i>Classification</i>	<b>H2</b>
Sensi di rotazione	<i>Direction of rotation</i>	<b>H3</b>
Simbologia	<i>Symbols</i>	<b>H3</b>
Lubrificazione	<i>Lubrication</i>	<b>H3</b>
Carichi radiali	<i>Radial loads</i>	<b>H4</b>
Dati tecnici	<i>Technical data</i>	<b>H4</b>
Dimensioni	<i>Dimensions</i>	<b>H5</b>

Questa sezione annulla e sostituisce ogni precedente edizione o revisione. Qualora questa sezione non Vi sia giunta in distribuzione controllata, l'aggiornamento dei dati ivi contenuto non è assicurato. **In tal caso la versione più aggiornata è disponibile sul nostro sito internet [www.transtecno.com](http://www.transtecno.com)**

*This section replaces any previous edition and revision. If you obtained this catalogue other than through controlled distribution channels, the most up to date content is not guaranteed. In this case the latest version is available on our web site [www.transtecno.com](http://www.transtecno.com)*

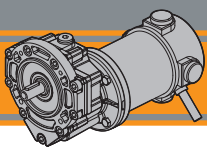

## Caratteristiche tecniche

## Technical features

I motoriduttori ad ingranaggi cilindrici monostadio NDPS presentano una compattezza che li rende ideali nelle applicazioni che necessitano di ingombri ridotti. Le caratteristiche principali sono:

NDPS single stage helical gearmotors introduce a unique compactness that makes them ideal for applications requiring reduced space. The main features are:

- Alimentazione in bassa tensione 12/24 Vcc
- Possibilità di montaggio encoder
- Potenze motore disponibili da 160 a 250W S2
- Magneti in Neodimio
- Carcasse dei riduttori in pressofusione di alluminio
- Lubrificazione permanente con olio sintetico
- Ingranaggi sempre rettificati

- Low voltage power supply 12/24 Vdc
- Suitable for encoder assembly
- Motor power ratings available from 160 to 250W S2
- Neodymium magnets
- Die-cast aluminum housing
- Permanent synthetic oil long-life lubrication
- Ground helical gears

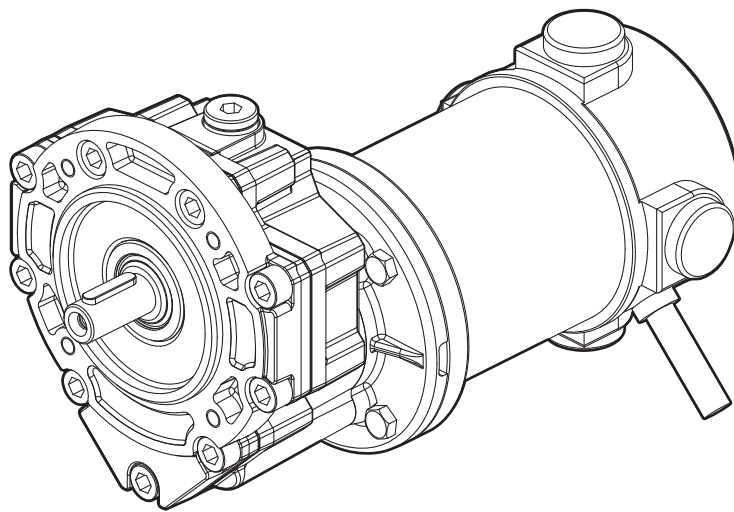

## Designazione

## Classification

MOTORIDUTTORE / GEARMOTOR						
NDPS	120/56		F63B14	3	D11	240
Tipo Type	Grandezza Size		Versione Riduttore Gearbox Version	Rapporto Ratio	Albero di uscita Output shaft	Versione Motore Motor Version
NDPS	120/56	180/56	F63B14 F71B14	3 5 8	D11 D14	120 240

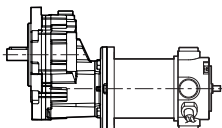

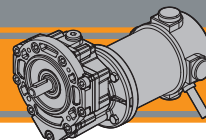

**Sensi di rotazione**

**Direction of rotation**

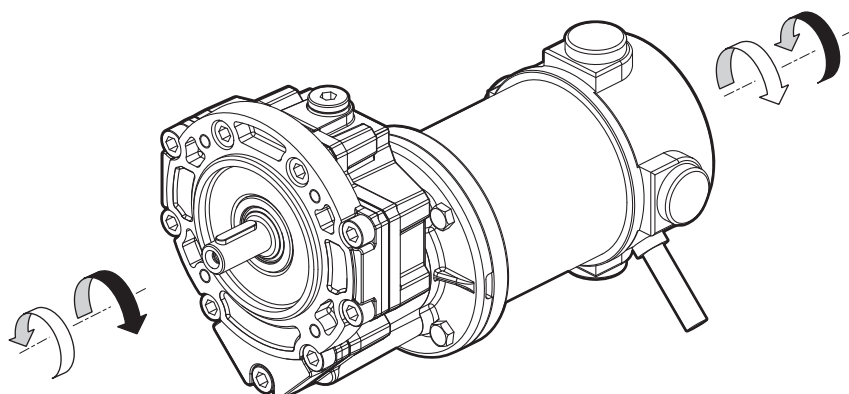

**Simbologia**

**Symbols**

$n_1$	[min <sup>-1</sup> ]	Velocità in ingresso / <i>Input speed</i>
$n_2$	[min <sup>-1</sup> ]	Velocità in uscita / <i>Output speed</i>
$i$		Rapporto di riduzione / <i>Ratio</i>
$P_1$	[kW]	Potenza in entrata / <i>Input power</i>
$M_2$	[Nm]	Coppia nominale in uscita in funzione di $P_1$ / <i>Output torque referred to <math>P_1</math></i>
$P_{n1}$	[kW]	Potenza nominale in entrata / <i>Nominal input power</i>
$M_{n2}$	[Nm]	Coppia nominale in uscita in funzione di $P_{n1}$ / <i>Nominal output torque referred to <math>P_{n1}</math></i>
$sf$		Fattore di servizio / <i>Service factor</i>
$R_2$	[N]	Carico radiale ammissibile in uscita / <i>Permitted output radial load</i>
$A_2$	[N]	Carico assiale ammissibile in uscita / <i>Permitted output axial load</i>

**Lubrificazione**

**Lubrication**

Tutti i motoriduttori sono forniti completi di lubrificante sintetico viscosità 320, pertanto possono essere installati in qualunque posizione di montaggio e non necessitano di manutenzione.

*Permanent synthetic oil long-life lubrication ( viscosity grade 320) makes it possible to use the gearmotors in all mounting positions; for this reason they can be installed in any assembly position and do not require maintenance.*

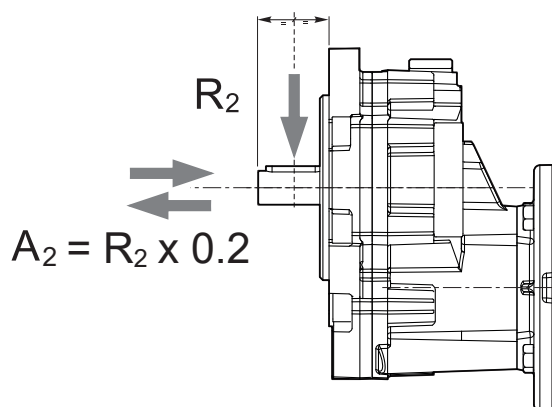
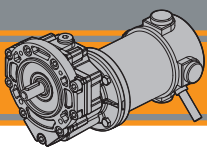

$n_2$ [min <sup>-1</sup> ]	$R_2$ [N]
	PS56
1000	300
600	350
470	400
375	500
280	500
175	500

Quando il carico radiale risultante non è applicato sulla mezza-  
ria dell'albero occorre calcolare quello effettivo con la seguente  
formula:

When the resulting radial load is not applied on the centre line  
of the shaft it is necessary to calculate the effective load with the  
following formula:

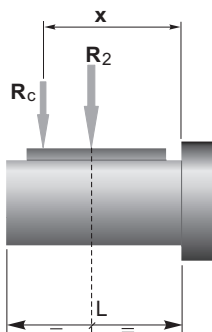

	PS56
a	47
b	35.5
$R_{2MAX}$	500

$$R_c = \frac{R_2 \cdot a}{(b + x)} \leq R_{2MAX}$$

a, b = valori riportati nella tabella  
a, b = values given in the table

$$R \leq R_c$$

### Dati tecnici

### Technical data

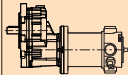
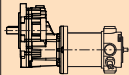
$P_1$ [W]	$n_2$ [min <sup>-1</sup> ]	$M_2$ [Nm]	sf	i		Versione motore Motor version	$P_1$ [W]	$n_2$ [min <sup>-1</sup> ]	$M_2$ [Nm]	sf	i		Versione motore Motor version
<b>160</b>							<b>250</b>						
(3000 min <sup>-1</sup> )	<b>1000</b>	1.5	7.3	3	<b>120/56</b>	120/240	(3000 min <sup>-1</sup> )	<b>1000</b>	2.3	4.7	3	<b>180/56</b>	120/240
	<b>600</b>	2.5	4.8	5				<b>600</b>	3.9	3.1	5		
	<b>375</b>	4.0	3.0	8				<b>375</b>	6.2	1.9	8		

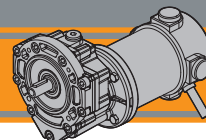

Dimensioni

Dimensions

NDPS 120/56

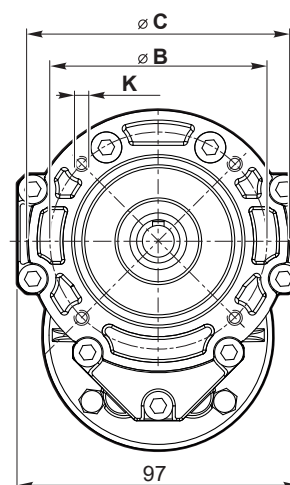
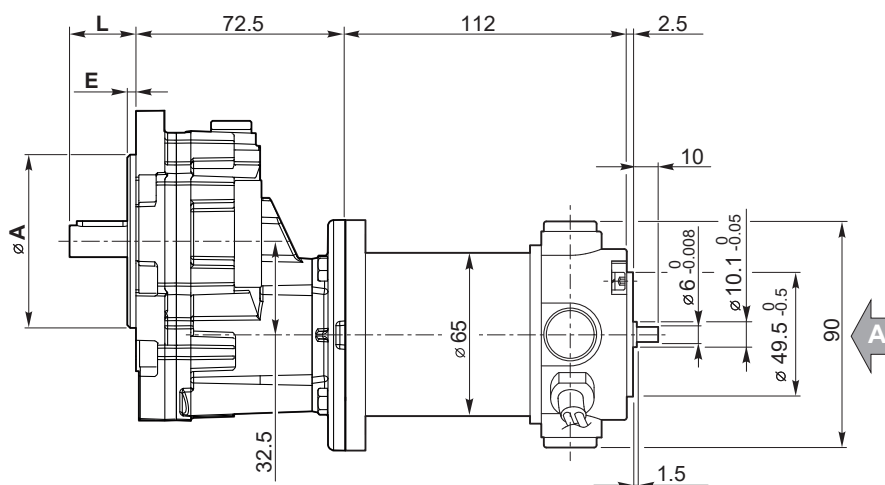

Albero uscita  
Output shaft

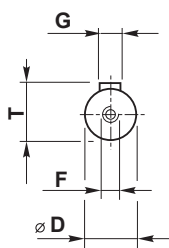

Vista da A  
View from A

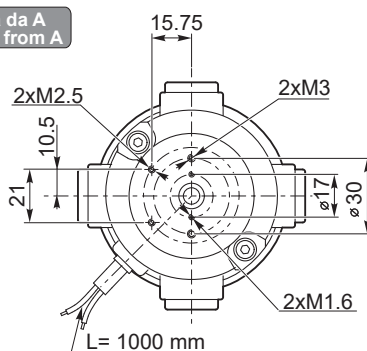

Freno / Brake



Encoder



Flangia uscita Output flange	A	B	C	E	K
F63B14	60	75	90	3	M5
F71B14	70	85	105	3	M6

Albero uscita Output shaft	D	L	F	G	T
D11	11	23	M4	4	12.5
D14	14	30	M5	5	16

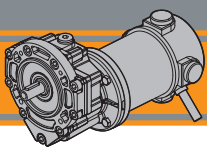

### NDPS 180/56

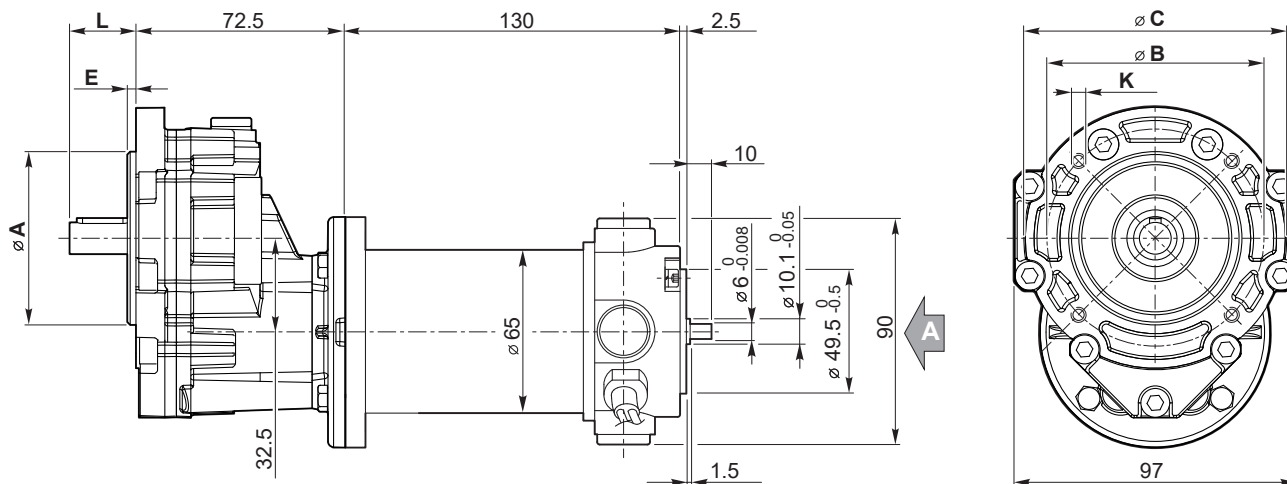

Albero uscita  
Output shaft

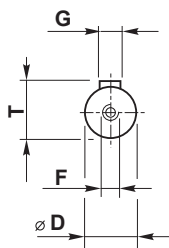

Vista da A  
View from A

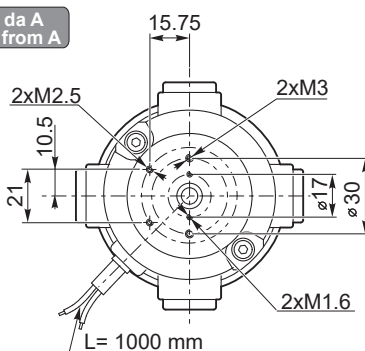

- Freno / Brake → B9
- Encoder → B9

Flangia uscita Output flange	A	B	C	E	K
F63B14	60	75	90	3	M5
F71B14	70	85	105	3	M6

Albero uscita Output shaft	D	L	F	G	T
D11	11	23	M4	4	12.5
D14	14	30	M5	5	16

**TRANSTECNO**<sup>®</sup>  
the modular gearmotor

EC

EC



Ferrite

## Motori elettrici CC DC electric motors





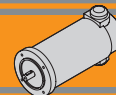

	<b>Indice</b>	<b>Index</b>	<b>Pag. Page</b>
	Caratteristiche tecniche	<i>Technical features</i>	<b>12</b>
	Simbologia	<i>Symbols</i>	<b>12</b>
	Grado di protezione IP	<i>IP enclosures protection indexes</i>	<b>13</b>
	Classe di isolamento termico	<i>Insulation class</i>	<b>13</b>
	Tipi di servizio IEC	<i>IEC duty cycle ratings</i>	<b>13</b>
<b>EC020.120</b>	Caratteristiche	<i>Features</i>	<b>14</b>
<b>EC020.24E</b>	Dimensioni	<i>Dimensions</i>	<b>14</b>
	Prestazioni	<i>Performances</i>	<b>15</b>
<b>EC035.120</b>	Caratteristiche	<i>Features</i>	<b>16</b>
<b>EC035.240</b>	Dimensioni	<i>Dimensions</i>	<b>16</b>
	Prestazioni	<i>Performances</i>	<b>17</b>
<b>EC050.12E</b>	Caratteristiche	<i>Features</i>	<b>18</b>
<b>EC050.24E</b>	Dimensioni	<i>Dimensions</i>	<b>18</b>
	Prestazioni	<i>Performances</i>	<b>19</b>
<b>EC070.12E</b>	Caratteristiche	<i>Features</i>	<b>110</b>
<b>EC070.24E</b>	Dimensioni	<i>Dimensions</i>	<b>110</b>
	Prestazioni	<i>Performances</i>	<b>111</b>
<b>EC100.120</b>	Caratteristiche	<i>Features</i>	<b>112</b>
<b>EC100.240</b>	Dimensioni	<i>Dimensions</i>	<b>112</b>
<b>EC100.24E</b>	Prestazioni	<i>Performances</i>	<b>113</b>
<b>EC180.120</b>	Caratteristiche	<i>Features</i>	<b>114</b>
<b>EC180.240</b>	Dimensioni	<i>Dimensions</i>	<b>114</b>
<b>EC180.24E</b>	Prestazioni	<i>Performances</i>	<b>115</b>
<b>EC250.120</b>	Caratteristiche	<i>Features</i>	<b>116</b>
<b>EC250.240</b>	Dimensioni	<i>Dimensions</i>	<b>116</b>
	Prestazioni	<i>Performances</i>	<b>117</b>
<b>EC350.120</b>	Caratteristiche	<i>Features</i>	<b>118</b>
<b>EC350.240</b>	Dimensioni	<i>Dimensions</i>	<b>118</b>
	Prestazioni	<i>Performances</i>	<b>119</b>
<b>EC600.120</b>	Caratteristiche	<i>Features</i>	<b>120</b>
<b>EC600.240</b>	Dimensioni	<i>Dimensions</i>	<b>120</b>
	Prestazioni	<i>Performances</i>	<b>121</b>
	Legenda / Glossario dei grafici	<i>Key / Diagram Glossary</i>	<b>122</b>
	Formule utili	<i>Useful formulas</i>	<b>122</b>
	Freni	<i>Brakes</i>	<b>123</b>
	Encoder	<i>Encoder</i>	<b>124</b>

Questa sezione annulla e sostituisce ogni precedente edizione o revisione. Qualora questa sezione non Vi sia giunta in distribuzione controllata, l'aggiornamento dei dati ivi contenuto non è assicurato. **In tal caso la versione più aggiornata è disponibile sul nostro sito internet [www.transtecno.com](http://www.transtecno.com)**

*This section replaces any previous edition and revision. If you obtained this catalogue other than through controlled distribution channels, the most up to date content is not guaranteed. In this case the latest version is available on our web site [www.transtecno.com](http://www.transtecno.com)*

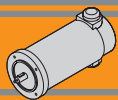

## Caratteristiche tecniche

Le caratteristiche principali dei motori elettrici CC a magneti permanenti in ferrite EC sono:

- Campo magnetico generato da magneti permanenti in ferrite
- Costruzione tubolare, senza ventilazione
- Disponibili in 6 grandezze: diametro 42, 52, 65, 81, 104, 110 mm
- Alimentazione a bassa tensione, 12 o 24 Vcc
- Potenze disponibili da 30 a 800 W S2
- Elevate coppie di spunto
- Elevate coppie e potenze in dimensioni compatte

### Classe di isolamento termico

Gli avvolgimenti del rotore sono soggetti a surriscaldamento, come pure altre parti del motore. Il grado di isolamento indica la massima temperatura ammissibile oltre la quale l'isolante della matassa e l'isolante di tutte le parti soggette ad elevato riscaldamento perde le caratteristiche di buon isolante, con pericolo di danneggiamento del motore.

### Servizio

Rappresenta la relazione tra il tempo di lavoro ed il tempo di riposo del motore. Servizio continuo (S1) = funzionamento continuo del motore a pieno carico.

Servizio intermittente (S2, S3, etc...) = periodi alternati di lavoro e di riposo tali da raffreddare il motore. Dato un motore, la potenza espressa per servizio continuo è inferiore a quella per servizio intermittente.

### Fattore di forma

Indica quanta componente spuria alternata è presente nella alimentazione CC del motore. Più alto è il fattore ed inferiore è l'efficienza del motore. Alimentatori ad SCR = F.F 1.40. Alimentazione pura da batteria = FF 1. Alimentazione da transistori (modulazione PWM) = FF 1.05.

Qualitativamente l'andamento della coppia (percentuale) rispetto al fattore di forma è indicato nel grafico seguente:

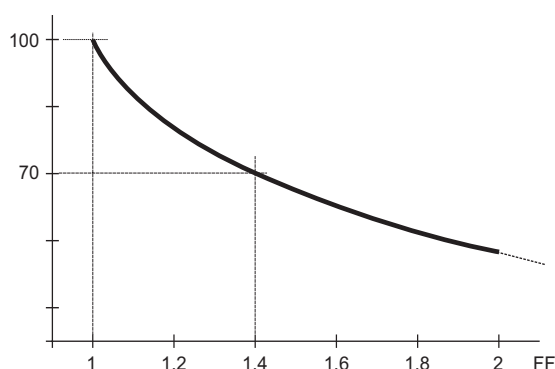

## Simbologia

<b>S</b>	—	Servizio / Duty
<b>P<sub>n</sub></b>	[W]	Potenza in uscita / Rated power
<b>P<sub>a</sub></b>	[W]	Potenza assorbita / Absorbed power
<b>M<sub>n</sub></b>	[Nm]	Coppia nominale / Rated torque
<b>V</b>	[V]	Tensione / Voltage
<b>I</b>	[A]	Corrente assorbita / Absorbed current
<b>n<sub>1</sub></b>	[min <sup>-1</sup> ]	Numero giri motore / Motor speed
<b>S<sub>v</sub></b>	[rad/s]	Velocità angolare / Angular speed
<b>P<sub>e</sub></b>	[W]	Potenza elettrica del freno / Brake electric power

The main features of EC ferrite permanent magnets DC electric motors range are:

- Magnetic field generated by permanent ferrite magnets
- Tubular construction, without fan
- Available in 6 sizes: diameter 42, 52, 65, 81, 104, 110 mm
- Low voltage power supply, 12 or 24 Vdc
- Power ratings available from 30 to 800 W S2
- High starting torque
- High torque and output power with compact package

### Thermal insulation class

The windings of the rotor can overheat just like other parts of the motor too. The degree of insulation indicates the maximum allowable temperature above which the insulation of the windings, as well as that of all the parts which heat up to a high temperature, loses its insulating properties and the motor therefore risks being damaged.

### Duty cycle

This represents the relationship between the time the motor operates and the time it remains stationary. Continuous operation (S1) = the motor operates non-stop under full load.

Intermittent operation (S2, S3, etc.) = alternating periods of work and rest so that the motor can cool down. The output power for continuous operation is lower than that for intermittent operation.

### Form factor

It indicates how much spurious alternating current is present in the D.C. motor power supply. The higher the factor, the lower the motor's efficiency. SCR power supplies = F.F 1.40. Battery supply = FF 1 Transistor supply (PWM modulation) = FF 1.05.

The graph below indicates the torque trend (percentage) in relation to the form factor.

## Symbols

<b>M<sub>Br</sub></b>	[Nm]	Coppia nominale del freno / Brake motor torque
<b>n<sub>1 max</sub></b>	[min <sup>-1</sup> ]	Velocità massima / Max speed
<b>T<sub>r</sub></b>	[ms]	Tempo di inserzione / Engaging time
<b>T<sub>f</sub></b>	[ms]	Tempo di disimpegno / Disengaging time
<b>IC</b>	—	Classe d'isolamento termico / Thermal insulation class
<b>FF</b>	—	Fattore di forma / Form factor
<b>IP</b>	—	Classe di protezione / Protection class
<b>η</b>	—	Rendimento / Efficiency
<b>Kg</b>	—	Peso / Weight

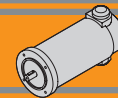

## Grado di protezione IP

## IP enclosures protection indexes

Indica il grado di isolamento meccanico del corpo motore.

1<sup>a</sup> cifra protezione alla penetrazione di corpi solidi.

2<sup>a</sup> cifra protezione contro la penetrazione d'acqua.

Indicates the degree of mechanical insulation of the motor body.

1<sup>st</sup> figure indicating level of protection against the penetration of solid bodies.

2<sup>nd</sup> figure: indicating degree to which the motor is waterproof.

<b>0</b>	Non protetto / No protection	<b>0</b>	Non protetto / No protection
<b>1</b>	Protetto da corpi solidi superiori a Ø 50 mm. <i>Protected against solid matters (over Ø 50 mm)</i>	<b>1</b>	Protetto contro la caduta verticale di gocce d'acqua. <i>Protected against drops of water falling vertically</i>
<b>2</b>	Protetto da corpi solidi superiori a Ø 12 mm. <i>Protected against solid matters (over Ø 12 mm)</i>	<b>2</b>	Protetto contro la caduta verticale di gocce d'acqua con inclinazione max di 15° <i>Protected against drops of water falling up to 15°</i>
<b>3</b>	Protetto da corpi solidi superiori a Ø 2,5 mm. <i>Protected against solid matters (over Ø 2,5 mm)</i>	<b>3</b>	Protetto contro la pioggia. <i>Rain proof fixture</i>
<b>4</b>	Protetto da corpi solidi superiori a Ø1 mm. <i>Protected against solid matters (over Ø1 mm)</i>	<b>4</b>	Protetto contro gli spruzzi. <i>Splash proof fixture</i>
<b>5</b>	Protetto contro la polvere <i>Dust proof</i>	<b>5</b>	Protetto contro getti d'acqua <i>Water jet proof</i>
<b>6</b>	Totalmente protetto contro la polvere <i>Fully dust proof</i>	<b>6</b>	Protetto dalle ondate <i>Wave proof</i>
<b>7</b>	N.A.	<b>7</b>	Protetto contro immersione <i>Watertight immersion fixture.</i>
<b>8</b>	N.A.	<b>8</b>	Protetto contro immersione/sommersione prolungata <i>Watertight immersion fixture for a long time.</i>

## Classe di isolamento termico

## Insulation class

Classe / Class	$\Delta t$ °C Temp. ambiente: 40°C <i>Ambient temperature: 40°C</i>
<b>A</b>	65°C
<b>B</b>	90°C
<b>F</b>	115°C
<b>H</b>	140°C

## Tipi di servizio IEC

## IEC duty cycle ratings

<b>S1</b>	<b>Servizio continuo.</b> Funzionamento a carico costante per una durata sufficiente al raggiungimento dell' equilibrio termico.	<b>Continuous duty.</b> The motor works at a constant load for enough time to reach temperature equilibrium
<b>S2</b>	<b>Servizio di durata limitata.</b> Funzionamento a carico costante per una durata inferiore a quella necessaria al raggiungimento dell' equilibrio termico, seguito da un periodo di riposo tale da riportare il motore alla temperatura ambiente.	<b>Short time duty.</b> The motor works at a constant load, but not long enough to reach temperature equilibrium, and the rest periods are long enough for the motor to reach ambient temperature.
<b>S3</b>	<b>Servizio periodico intermittente.</b> Sequenze di cicli identici di marcia e di riposo a carico costante, senza raggiungimento dell' equilibrio termico. La corrente di spunto ha effetti trascurabili sul surriscaldamento del motore.	<b>Intermittent periodic duty.</b> Sequential, identical run and rest cycles with constant load. Temperature equilibrium is never reached. Starting current has little effect on temperature rise.
<b>S4</b>	<b>Servizio periodico intermittente con avviamento.</b> Sequenza di cicli di funzionamento identici di avviamento, marcia e riposo a carico costante, senza raggiungimento dell'equilibrio termico. La corrente di spunto ha effetti sul riscaldamento del motore.	<b>Intermittent periodic duty with starting.</b> Sequential identical start, run and rest cycles with constant load. Temperature equilibrium is not reached, but starting current affects temperature rise.
<b>S5</b>	<b>Servizio periodico intermittente con frenatura elettrica.</b> Sequenza di cicli di funzionamento identici di avviamento, marcia a carico costante, frenatura elettrica e riposo, senza raggiungimento dell'equilibrio termico.	<b>Intermittent periodic duty with electric braking.</b> Sequential, identical cycles of starting, running at constant load, electric braking and rest. Temperature equilibrium is not reached.
<b>S6</b>	<b>Servizio periodico ininterrotto con carico intermittente.</b> Sequenza di cicli di lavoro identici con carico costante e senza carico. Non ci sono periodi di riposo.	<b>Continuous operation with intermittent load.</b> Sequential, identical cycles of running with constant load and running with no load. No rest periods.
<b>S7</b>	<b>Servizio periodico ininterrotto con frenatura elettrica.</b> Sequenza di cicli di funzionamento identici di avviamento, marcia a carico costante e frenatura elettrica, senza periodi di riposo.	<b>Continuous operation with electric braking.</b> Sequential, identical cycles of starting, running at constant load and electric braking. No rest periods.
<b>S8</b>	<b>Servizio periodico ininterrotto con variazioni di carico e di velocità.</b> Sequenza di cicli identici di avviamento, marcia a carico costante e velocità definita, seguiti da marcia a carico costante differente e velocità differente dalla precedente. Non ci sono periodi di riposo.	<b>Continuous operation with periodic changes in load and speed.</b> Sequential, identical, duty cycles of start, run at constant load and given speed, then run at other constant loads and speeds. No rest periods.

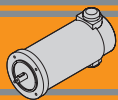

**EC020.120 - EC020.24E**

**Caratteristiche**

**Features**

Costruzione	Tubolare, senza ventilazione
Grandezza	Ø 42 mm
Potenza	30 W S2 (20 W S1)
Magneti	2
Supporti	Cuscinetti a sfera
Fori di montaggio	4
Alimentazione	Bassa tensione, 12 o 24 Vcc
Spazzole	N° 2 di composto grafite-rame
Cavo di alimentazione	Connettori faston (0.8 x 2.8 mm)
Opzioni	Filtro EMC

Construction	Tubular, without fan
Size	Ø 42 mm
Power	30 W S2 (20 W S1)
Magnets	2
Bearings	Ball bearing
Mounting holes	4
Power supply	Low voltage, 12 or 24 Vdc
Brushes	2 brushes made of graphite/copper composite
Electric cable	Faston terminals (0.8 x 2.8 mm)
Options	EMC filter

Tipo Type	S	Pn [W]	V [V]	I [A]	IC	FF	Mn [Nm]	n <sub>1</sub> [min <sup>-1</sup> ]	IP	Kg
EC020.120	S1	20	12	2.6	B	1	0.06	2850	20	0.4
	S2 6'	30		3.5			0.08			
EC020.24E	S1	20	24	1.4			0.06			
	S2 6'	30		1.9			0.08			

**Dimensioni**

**Dimensions**

**EC020.120**

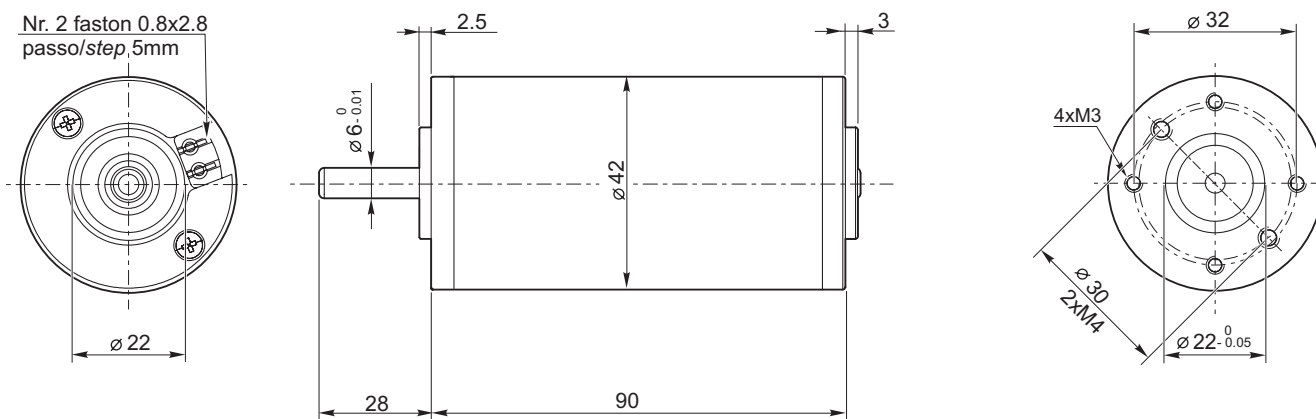

**EC020.24E**

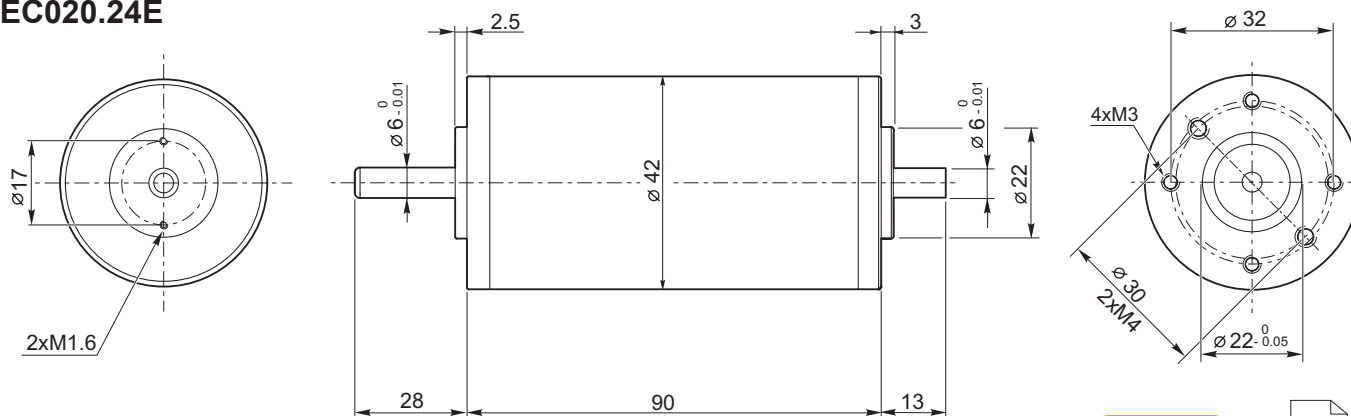

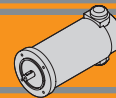

**EC020.120 - EC020.24E**

Prestazioni

Performances

**EC020.120**

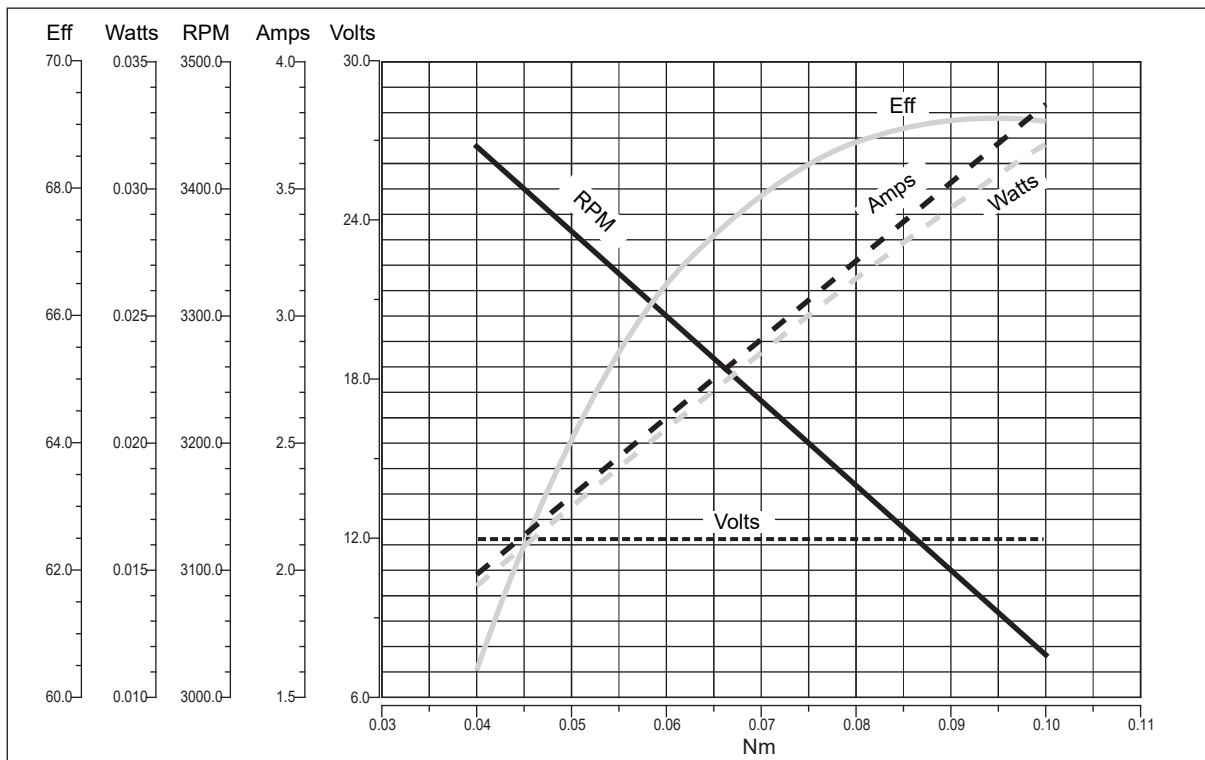

**EC020.24E**

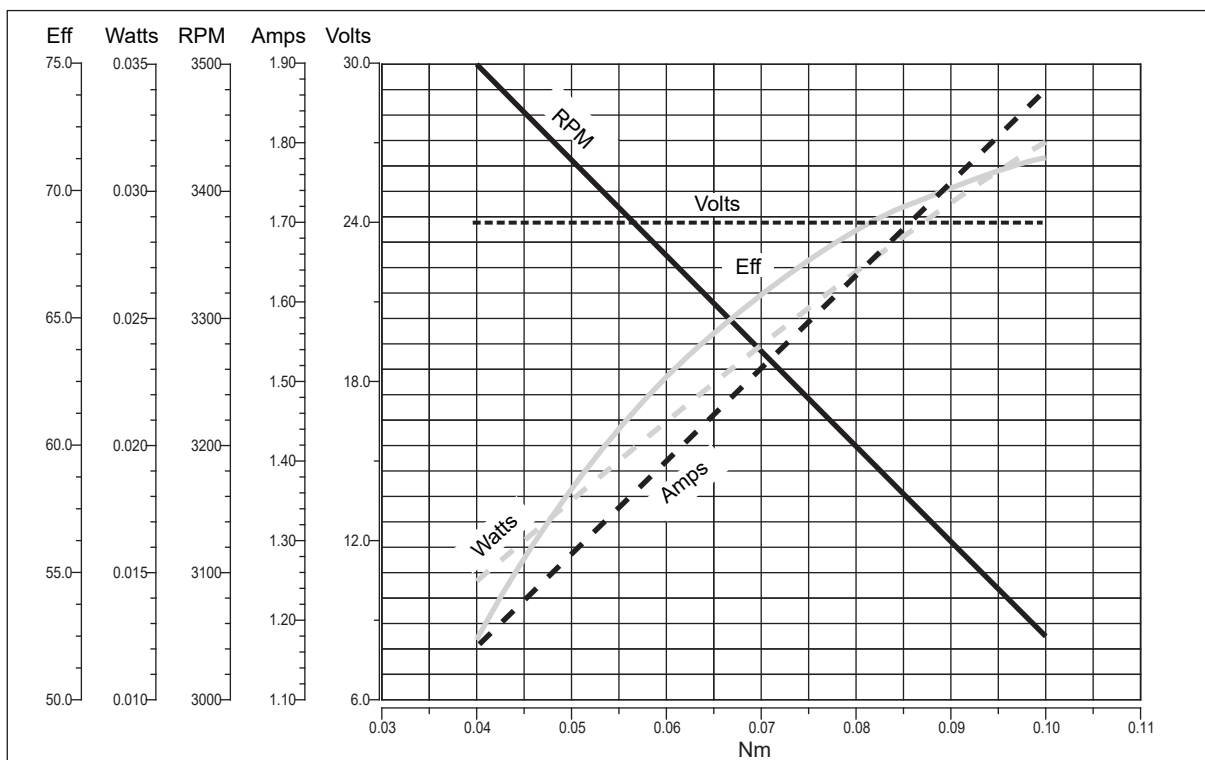

EC

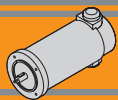

**EC035.120 - EC035.240**

**Caratteristiche**

**Features**

Costruzione	Tubolare, senza ventilazione
Grandezza	Ø 52 mm
Potenza	55 W S2 (35 W S1)
Magneti	2
Supporti	Cuscinetti a sfera
Fori di montaggio	4
Alimentazione	Bassa tensione, 12 o 24 Vcc
Spazzole	N° 2 interne di composto grafite-rame
Cavo di alimentazione	Lunghezza: 200 mm

Construction	Tubular, without fan
Size	Ø 52 mm
Power	55 W S2 (35 W S1)
Magnets	2
Bearings	Ball bearings
Mounting holes	4
Power supply	Low voltage, 12 or 24 Vdc
Brushes	2 inside brushes made of graphite/copper composite
Electric cable	Length: 200 mm

Tipo Type	S	Pn [W]	V [V]	I [A]	IC	FF	Mn [Nm]	n <sub>1</sub> [min <sup>-1</sup> ]	IP	Kg
EC035.120	S1	35	12	5.2	F	1	0.11	3000	20	0.8
	S2 9'	55		8.0			0.18			
EC035.240	S1	35	24	2.6	F	1	0.11		20	0.8
	S2 9'	55		4.0			0.18			

**Dimensioni**

**Dimensions**

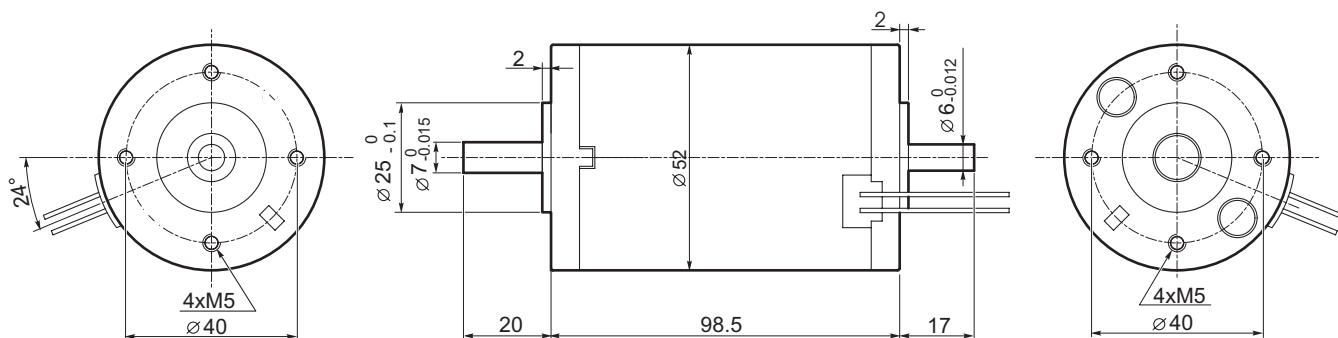

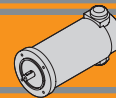

**EC035.120 - EC035.240**

Prestazioni

Performances

**EC035.120**

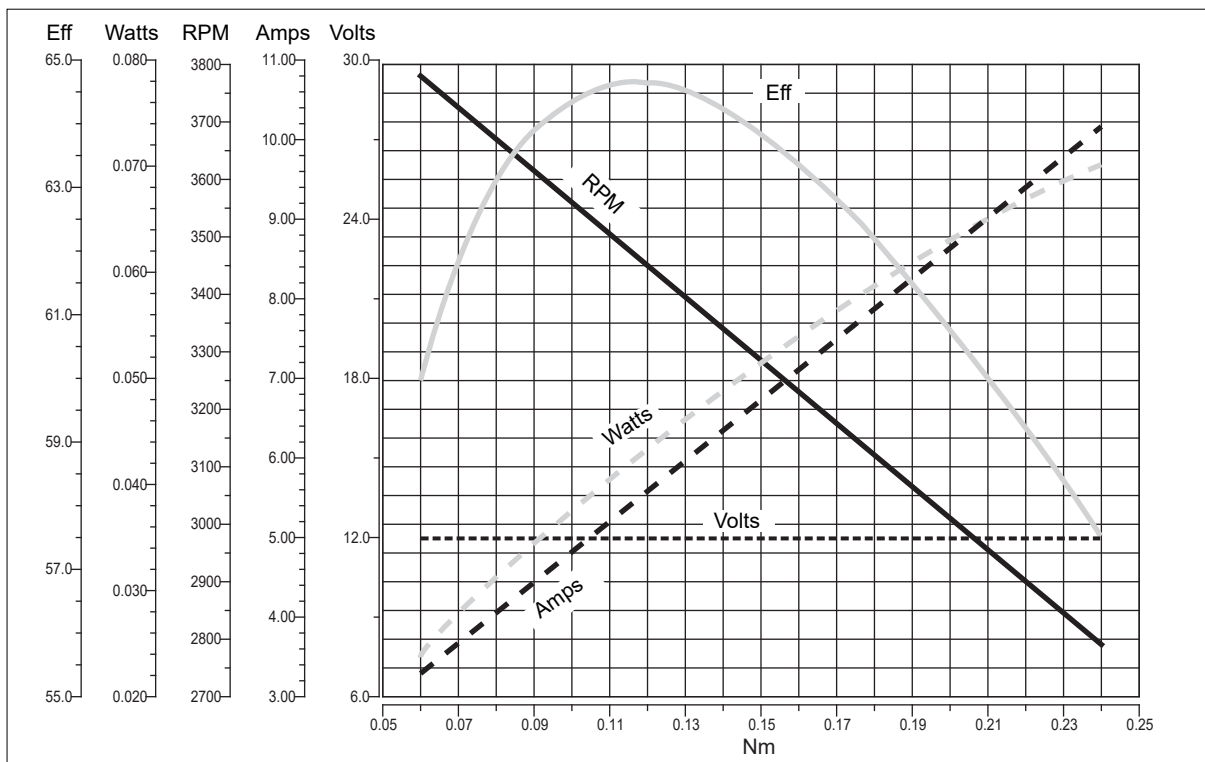

**EC035.240**

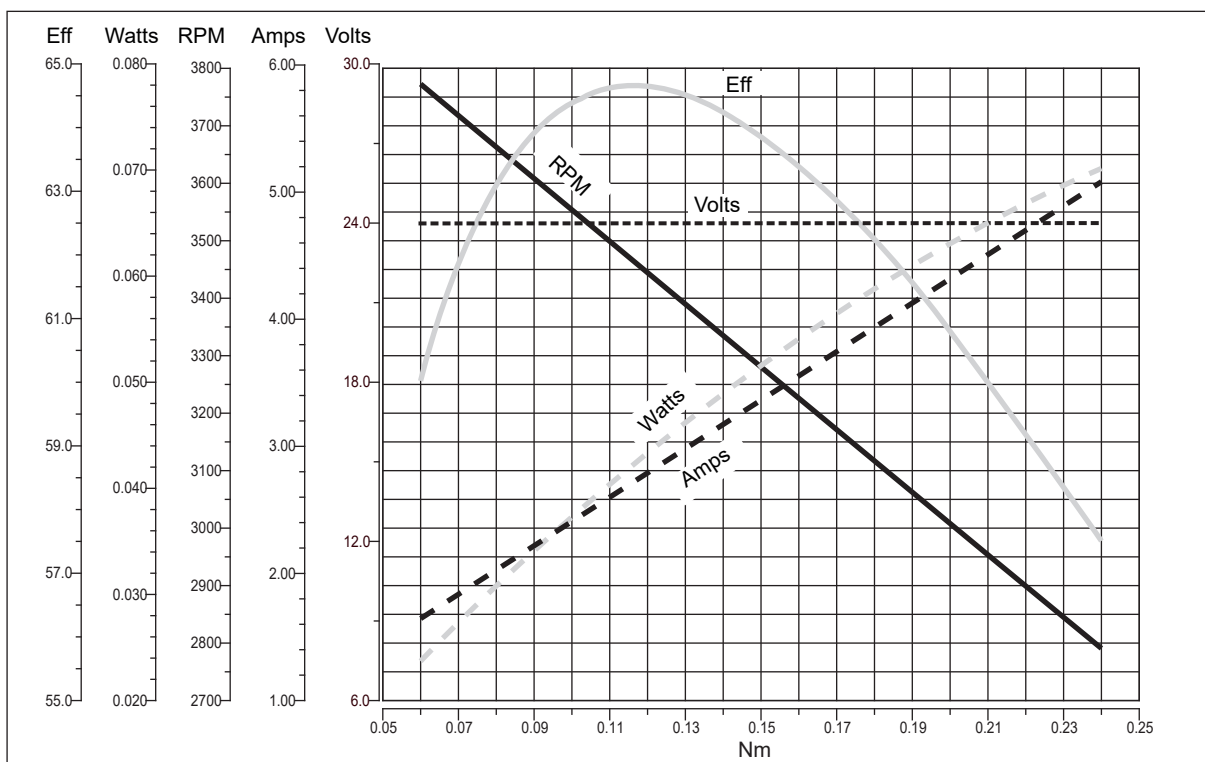

EC

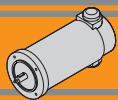

**EC050.12E - EC050.24E**

**Caratteristiche**

**Features**

Costruzione	Tubolare, senza ventilazione
Grandezza	Ø 65 mm
Potenza	70 W S2 (50 W S1)
Magneti	2
Supporti	Cuscinetti a sfera
Fori di montaggio	4
Alimentazione	Bassa tensione, 12 o 24 Vcc
Spazzole	N° 2 interne di composto grafite-rame
Cavo di alimentazione	Lunghezza: 200 mm
Bisporgenza	Standard

Construction	Tubular, without fan
Size	Ø 65 mm
Power	70 W S2 (50 W S1)
Magnets	2
Bearings	Ball bearings
Mounting holes	4
Power supply	Low voltage, 12 or 24 Vdc
Brushes	2 inside brushes made of graphite/copper composite
Electric cable	Length: 200 mm
Rear Shaft	Standard

Tipo Type	S	Pn [W]	V [V]	I [A]	IC	FF	Mn [Nm]	n <sub>1</sub> [min <sup>-1</sup> ]	IP	Kg
EC050.12E	S1	50	12	6.5	F	1	0.16	3000	20	1.2
	S2 30'	70		9.0			0.22			
EC050.24E	S1	50	24	3.2			0.16			
	S2 30'	70		4.5			0.22			

**Dimensioni**

**Dimensions**

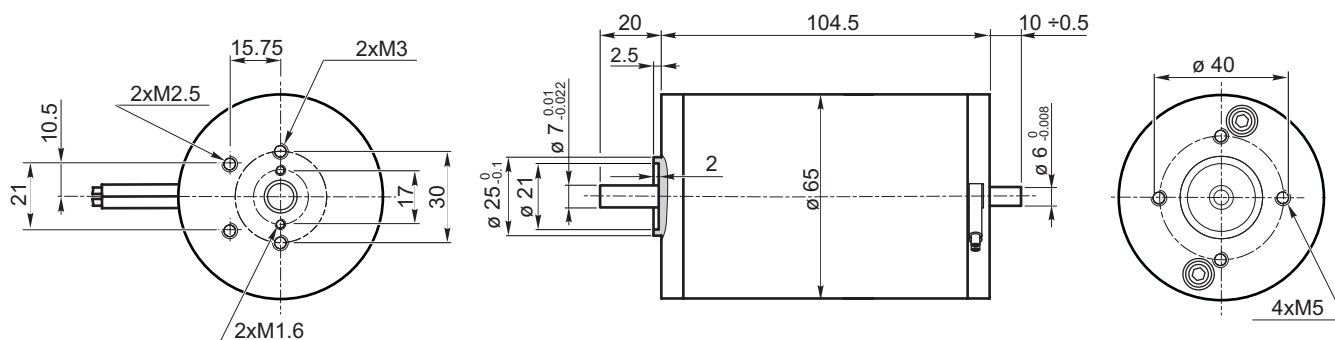

Freno / Brake → I23

Encoder → I24

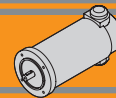

**EC050.12E - EC050.24E**

Prestazioni

Performances

**EC050.12E**

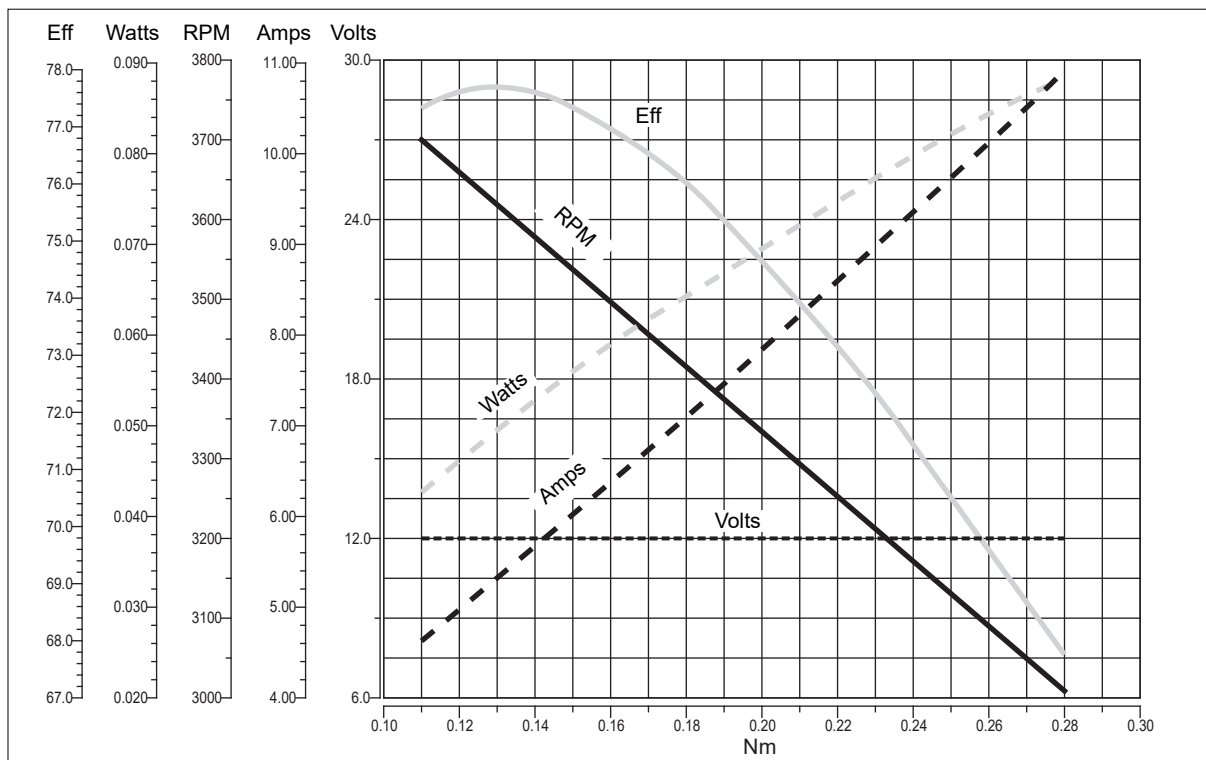

**EC050.24E**

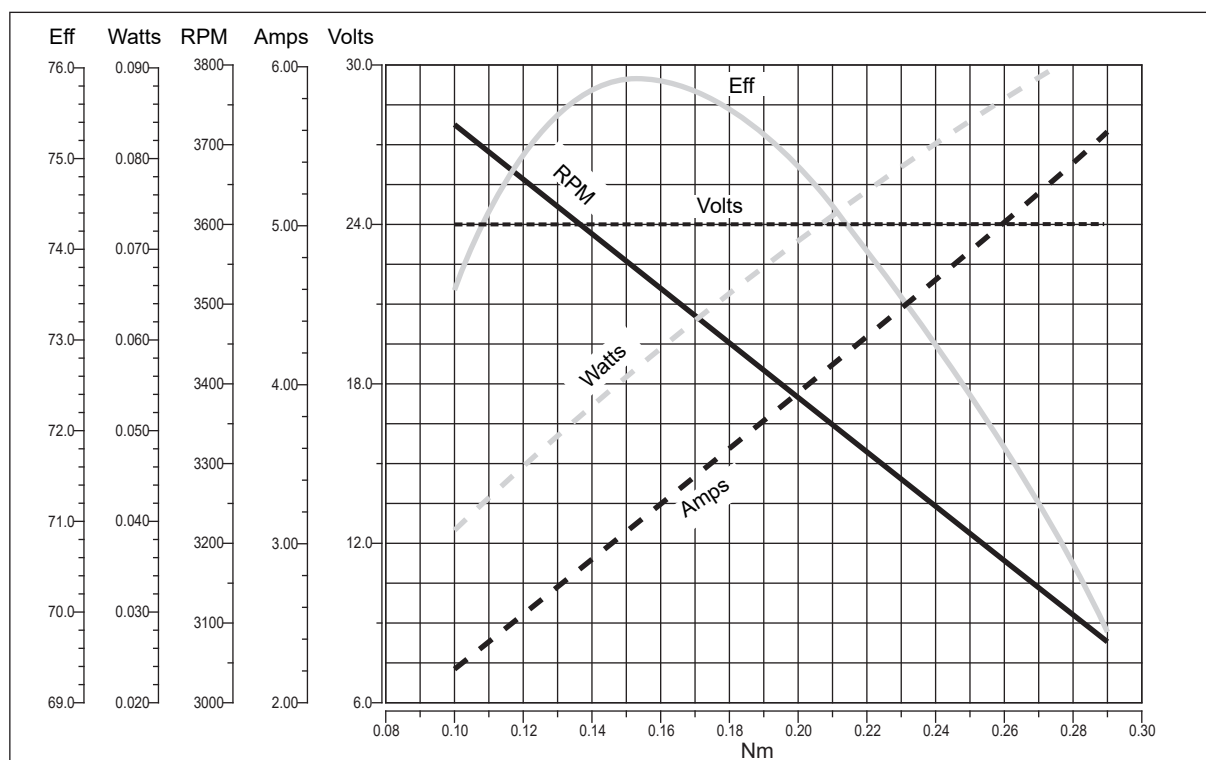

EC

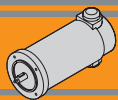

**EC070.12E - EC070.24E**

**Caratteristiche**

**Features**

Costruzione	Tubolare, senza ventilazione
Grandezza	Ø 65 mm
Potenza	100 W S2
Magneti	2
Supporti	Cuscinetti a sfera
Fori di montaggio	4
Alimentazione	Bassa tensione, 12 o 24 Vcc
Spazzole	N° 2 interne di composto grafite-rame
Cavo di alimentazione	Lunghezza: 1000 mm

Construction	Tubular, without fan
Size	Ø 65 mm
Power	100 W S2
Magnets	2
Bearings	Ball bearings
Mounting holes	4
Power supply	Low voltage, 12 or 24 Vdc
Brushes	2 inside brushes made of graphite/copper composite
Electric cable	Length: 1000 mm

Tipo Type	S	Pn [W]	V [V]	I [A]	IC	FF	Mn [Nm]	n <sub>1</sub> [min <sup>-1</sup> ]	IP	Kg					
EC070.12E	S1	70	12	8.4	F	1	0.22	3000	20	1.7					
	S2 30'	100		11.8			0.31								
EC070.24E	S1	70	24	4.2								0.22			
	S2 30'	100		5.9								0.31			

**Dimensioni**

**Dimensions**

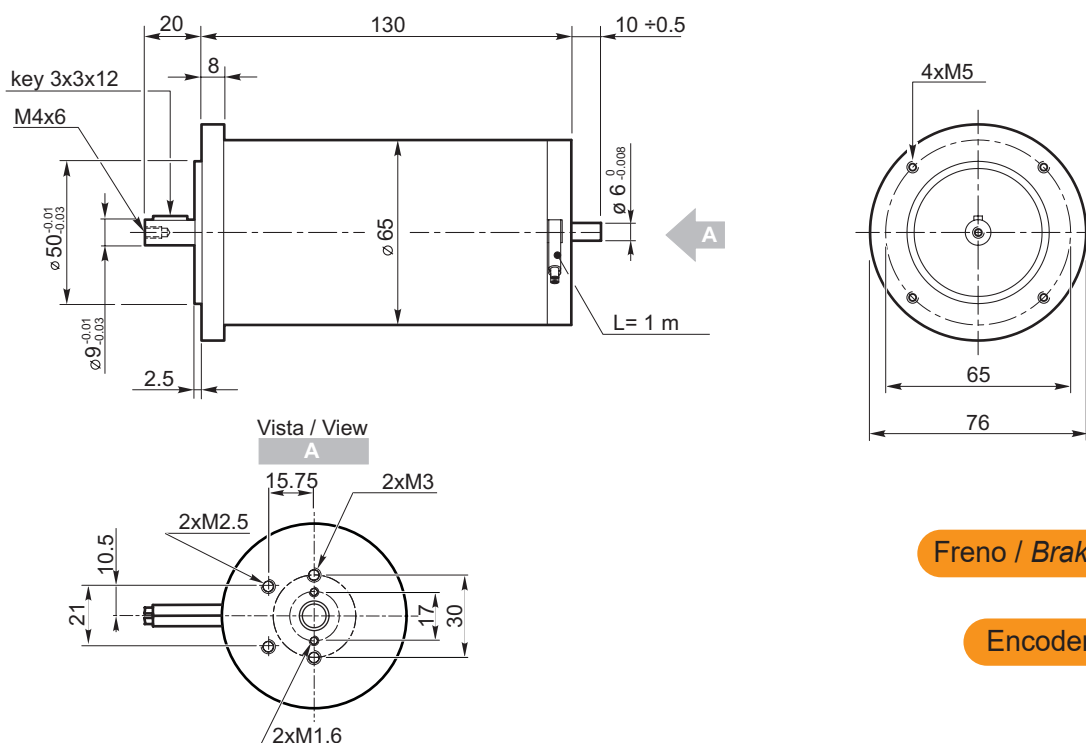

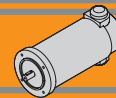

**EC070.12E - EC070.24E**

Prestazioni

Performances

**EC070.12E**

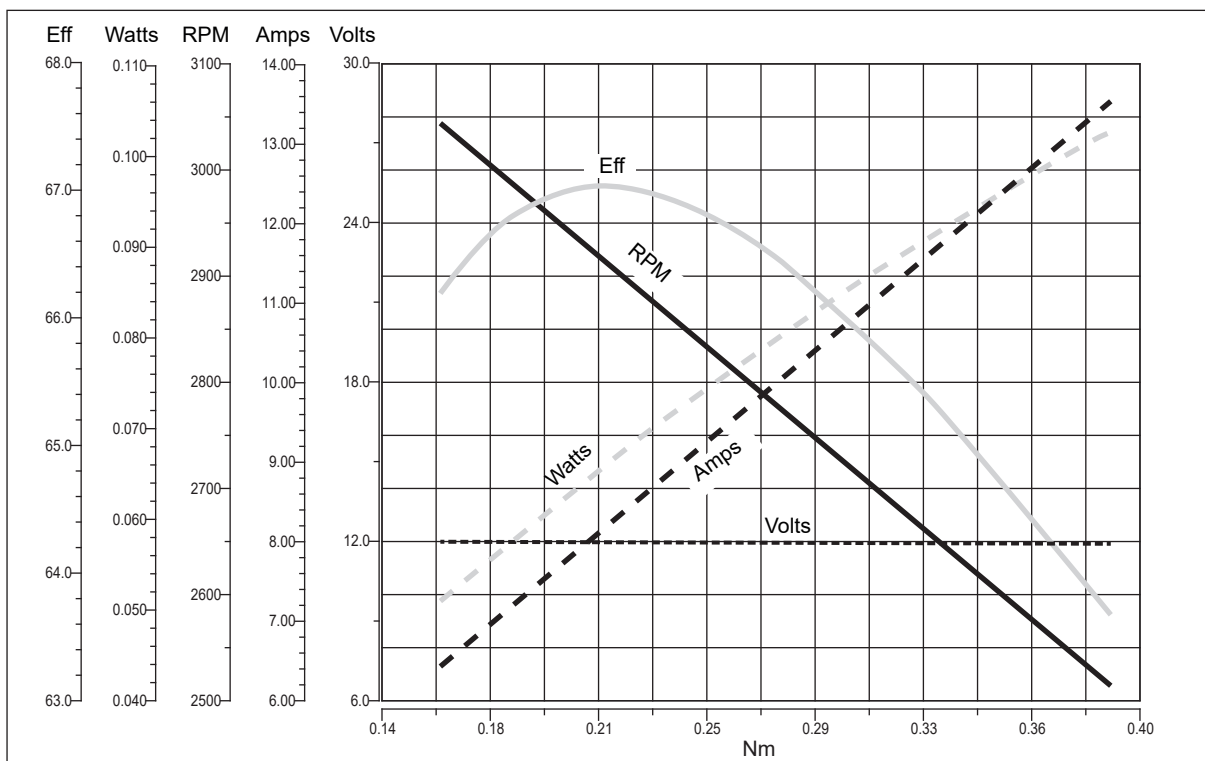

**EC070.24E**

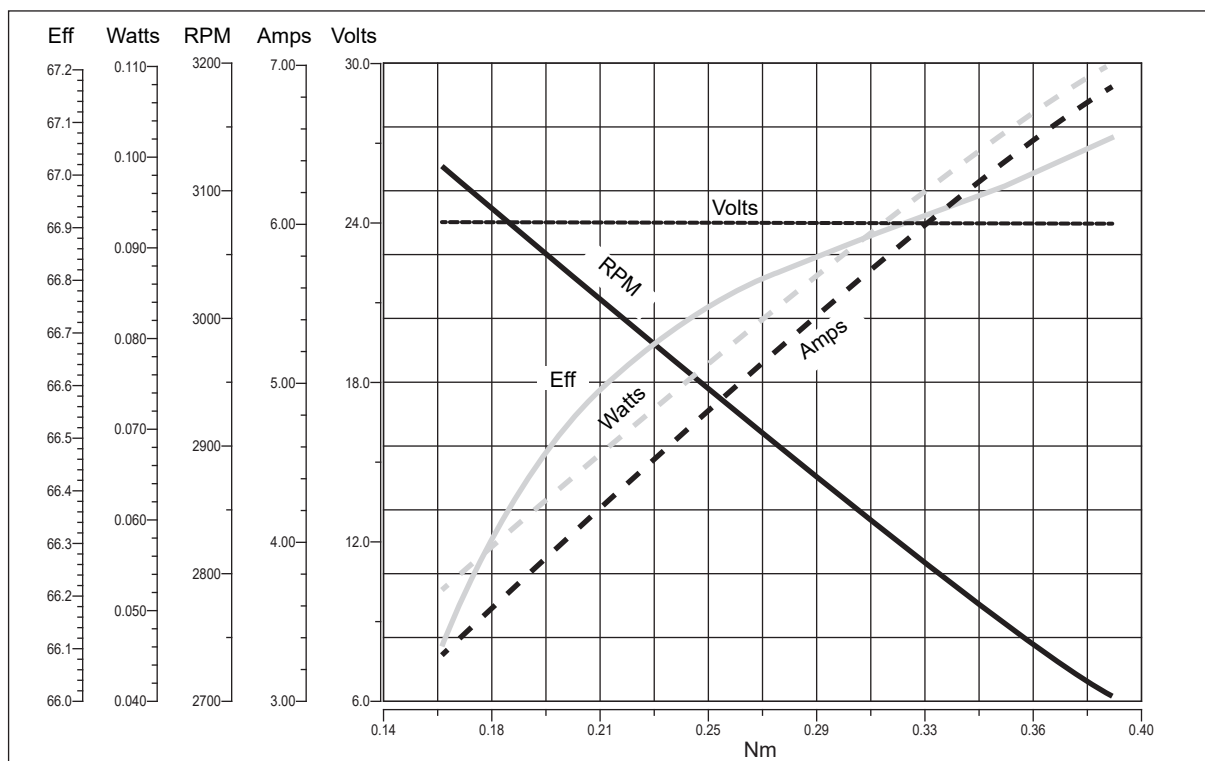

EC

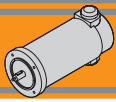

**EC100.120 - EC100.240 - EC100.24E**

**Caratteristiche**

**Features**

Costruzione	Tubolare, senza ventilazione
Grandezza	Ø 80 mm
Potenza	140 W S2 (100 W S1)
Magneti	2
Supporti	Cuscinetti a sfera
Fori di montaggio	4
Alimentazione	Bassa tensione, 12 o 24 Vcc
Spazzole	N° 2 di composto grafite-rame
Dimensione spazzole	LxPxH = 17.1 x 6.5 x 16.7 mm
Cavo di alimentazione	Lunghezza: 1000 mm
Bisporgenza	Standard solo EC100.24E

Construction	Tubular, without fan
Size	Ø 80 mm
Power	140 W S2 (100 W S1)
Magnets	2
Bearings	Ball bearings
Mounting holes	4
Power supply	Low voltage, 12 or 24 Vdc
Brushes	2 inside brushes made of graphite/copper composite
Brushes size	LxWxH = 17.1 x 6.5 x 16.7 mm
Electric cable	Length: 1000 mm
Rear shaft	Standard only EC100.24E

Tipo Type	S	Pn [W]	V [V]	I [A]	IC	FF	Mn [Nm]	n <sub>1</sub> [min <sup>-1</sup> ]	IP	Kg
EC100.120	S1	100	12	12	F	1	0.31	3000	40	2.7
	S2 25'	140		16.8			0.43			
EC100.240	S1	100	24	6			0.31			
	S2 25'	140		8.4			0.43			
EC100.24E	S1	100	24	6			0.31		20	
	S2 25'	140		8.4			0.43			

**Dimensioni**

**Dimensions**

**EC100.120  
EC100.240**

56 B14	
L	153
D	80
S	65
C (-0.01 / -0.03)	50
63B14*	
L	155
D	90
S	75
C (-0.01 / -0.03)	60

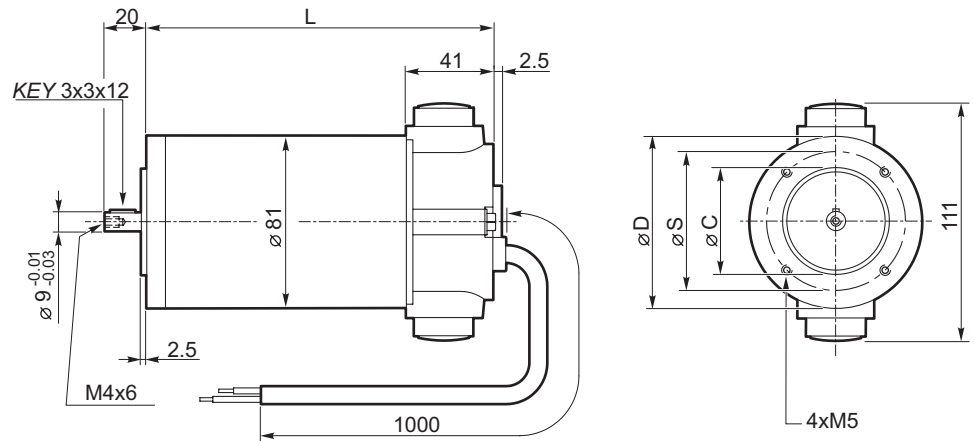

\* Usare boccola 9/11  
\* Use sleeve 9/11

Freno / Brake → I23

Encoder → I24

**EC100.24E**

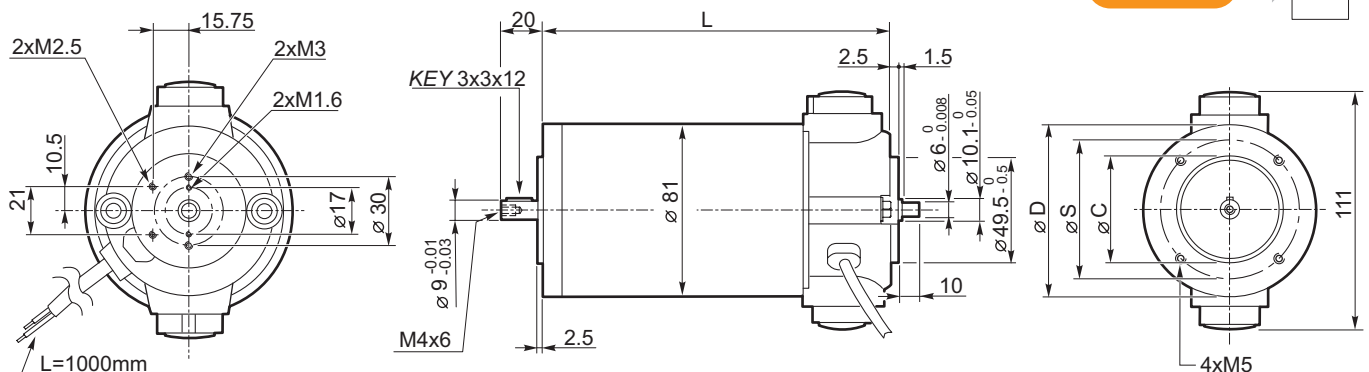

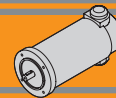

**EC100.120 - EC100.240 - EC100.24E**

Prestazioni

Performances

**EC100.120**

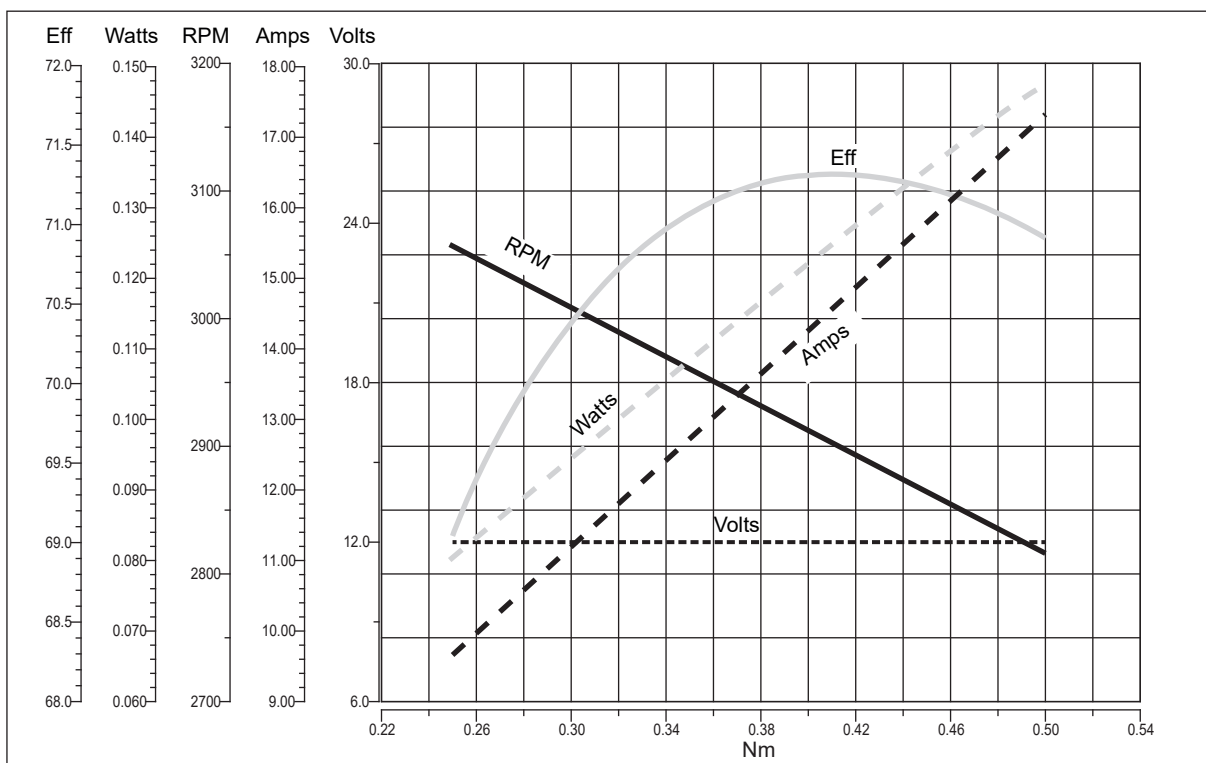

**EC100.240 - EC100.24E**

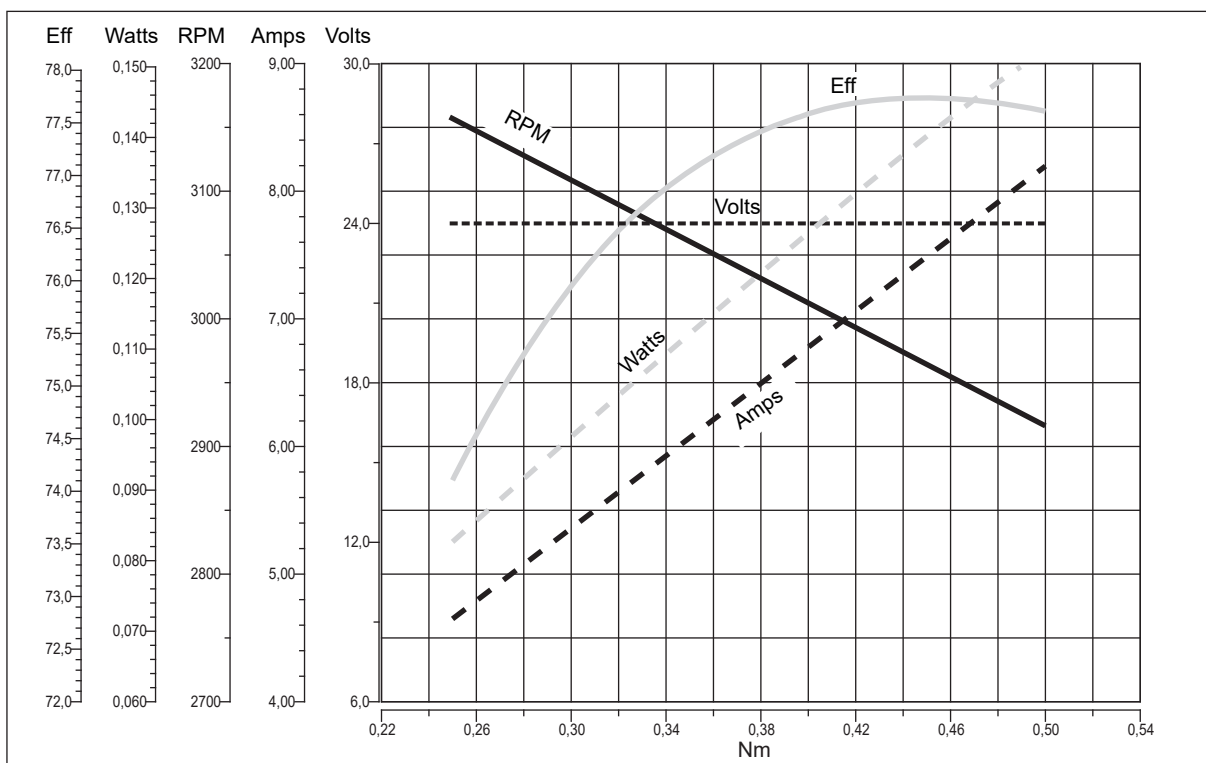

EC

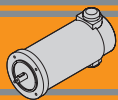

**EC180.120 - EC180.240 - EC180.24E**

**Caratteristiche**

**Features**

Costruzione	Tubolare, senza ventilazione
Grandezza	Ø 80 mm
Potenza	250 W S2 (180 W S1)
Magneti	2
Supporti	Cuscinetti a sfera
Fori di montaggio	4
Alimentazione	Bassa tensione, 12 o 24 Vcc
Spazzole	N° 2 di composto grafite-rame
Dimensione spazzole	LxPxH = 17.1 x 6.5 x 16.7 mm
Cavo di alimentazione	Lunghezza: 1000 mm
Bisporgenza	Standard solo EC180.24E

Construction	Tubular, without fan
Size	Ø 80 mm
Power	250 W S2 (180 W S1)
Magnets	2
Bearings	Ball bearings
Mounting holes	4
Power supply	Low voltage, 12 or 24 Vdc
Brushes	2 inside brushes made of graphite/copper composite
Brushes size	LxPxH = 17.1 x 6.5 x 16.7 mm
Electric cable	Length: 1000 mm
Rear shaft	Standard only EC180.24E

Tipo Type	S	Pn [W]	V [V]	I [A]	IC	FF	Mn [Nm]	n <sub>1</sub> [min <sup>-1</sup> ]	IP	Kg
EC180.120	S1	180	12	21.5	F	1	0.57	3000	40	3.4
	S2 25'	250		30			0.8			
EC180.240	S1	180	24	10.8			0.57			
	S2 25'	250		15			0.8			
EC180.24E	S1	180		10.8			0.57		20	
	S2 25'	250		15			0.8			

**Dimensioni**

**Dimensions**

**EC180.120  
EC180.240**

56 B14	
L	185
D	80
S	65
C (-0.01 / -0.03)	50
63B14*	
L	187
D	90
S	75
C (-0.01 / -0.03)	60

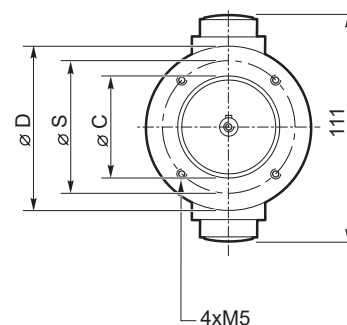
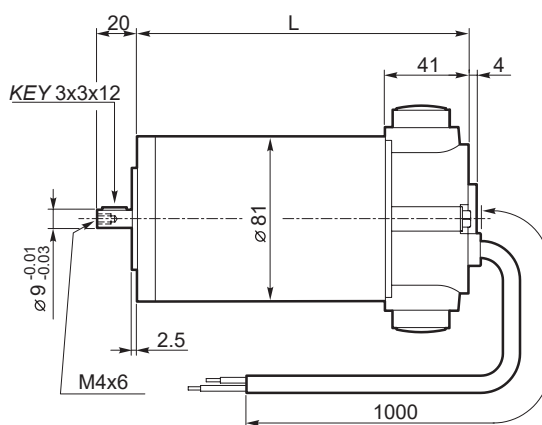

\* Usare boccola 9/11  
\* Use sleeve 9/11

Freno / Brake

I23

Encoder

I24

**EC180.24E**

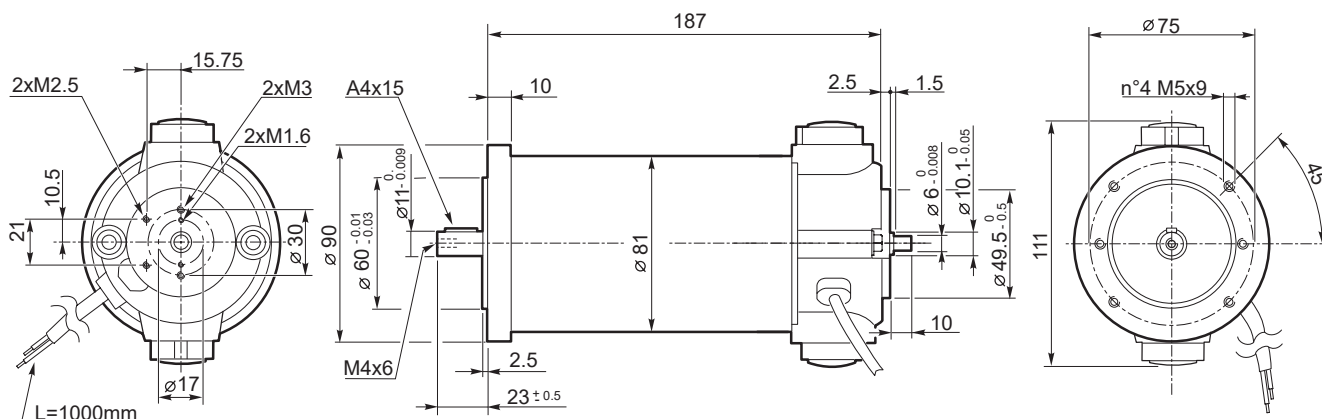

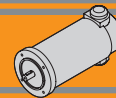

**EC180.120 - EC180.240 - EC180.24E**

Prestazioni

Performances

**EC180.120**

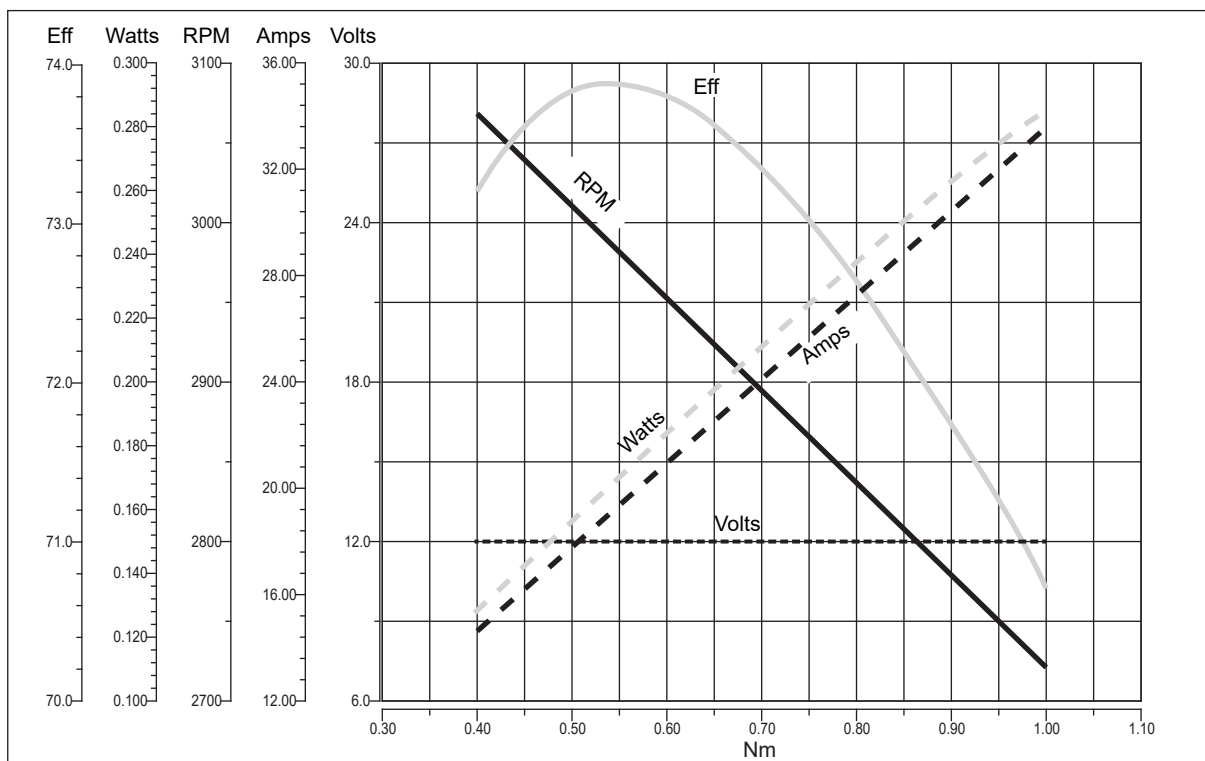

**EC180.240 - EC180.24E**

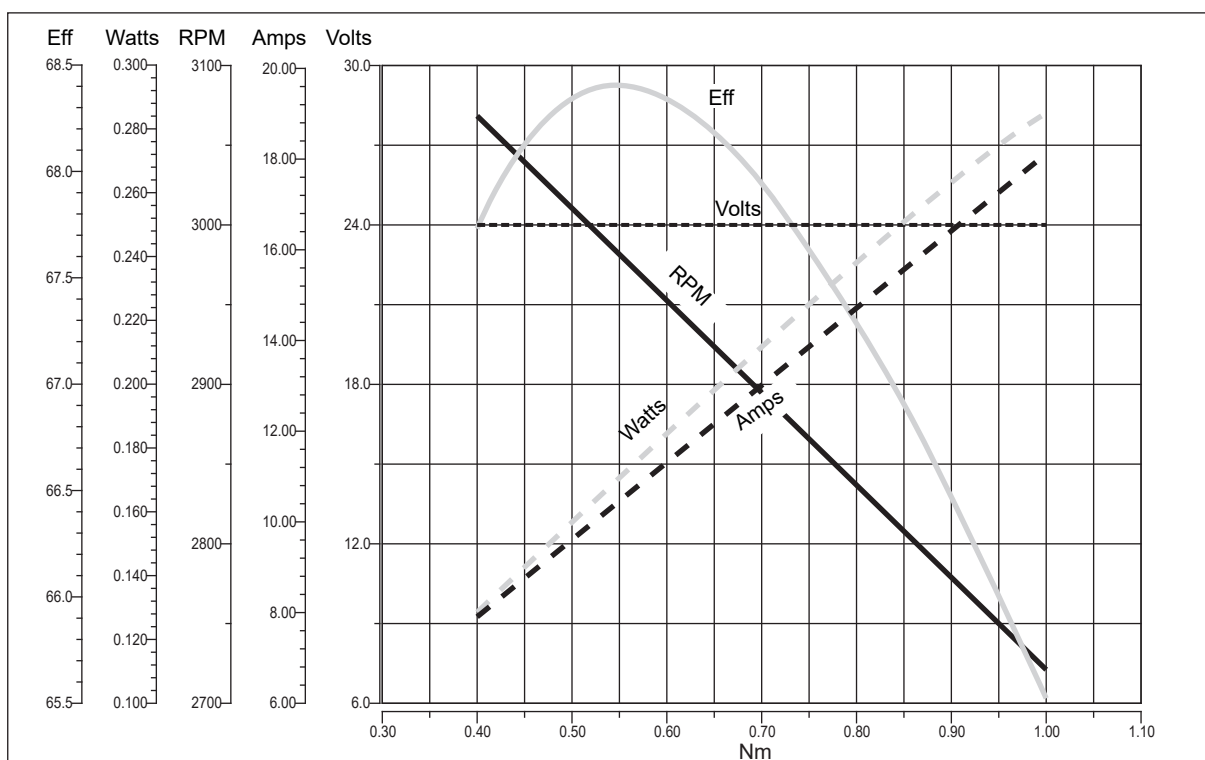

EC

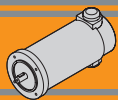

**EC250.120 - EC250.240**

**Caratteristiche**

**Features**

Costruzione	Tubolare, senza ventilazione
Grandezza	Ø 104 mm
Potenza	350 W S2 (250 W S1)
Magneti	4
Supporti	Cuscinetti a sfera
Fori di montaggio	8
Alimentazione	Bassa tensione, 12 o 24 Vcc
Spazzole	N° 4 di composto grafite-rame
Dimensione spazzole	LxPxH = 18.9 x 9.5 x 16.7 mm
Terminali	2 con doppio dado di fissaggio

Construction	Tubular, without fan
Size	Ø 104 mm
Power	350 W S2 (250 W S1)
Magnets	4
Bearings	Ball bearings
Mounting holes	8
Power supply	Low voltage, 12 or 24 Vdc
Brushes	4 inside brushes made of graphite/copper composite
Brushes size	LxPxH = 18.9 x 9.5 x 16.7 mm
Leads terminals	2, with double nut

Tipo Type	S	Pn [W]	V [V]	I [A]	IC	FF	Mn [Nm]	n <sub>1</sub> [min <sup>-1</sup> ]	IP	Kg
EC250.120	S1	250	12	30	F	1	0.8	3000	40	4.15
	S2 25'	350		38.5			1.12			
EC250.240	S1	250	24	15			0.8			
	S2 25'	350		20.5			1.12			

**Dimensioni**

**Dimensions**

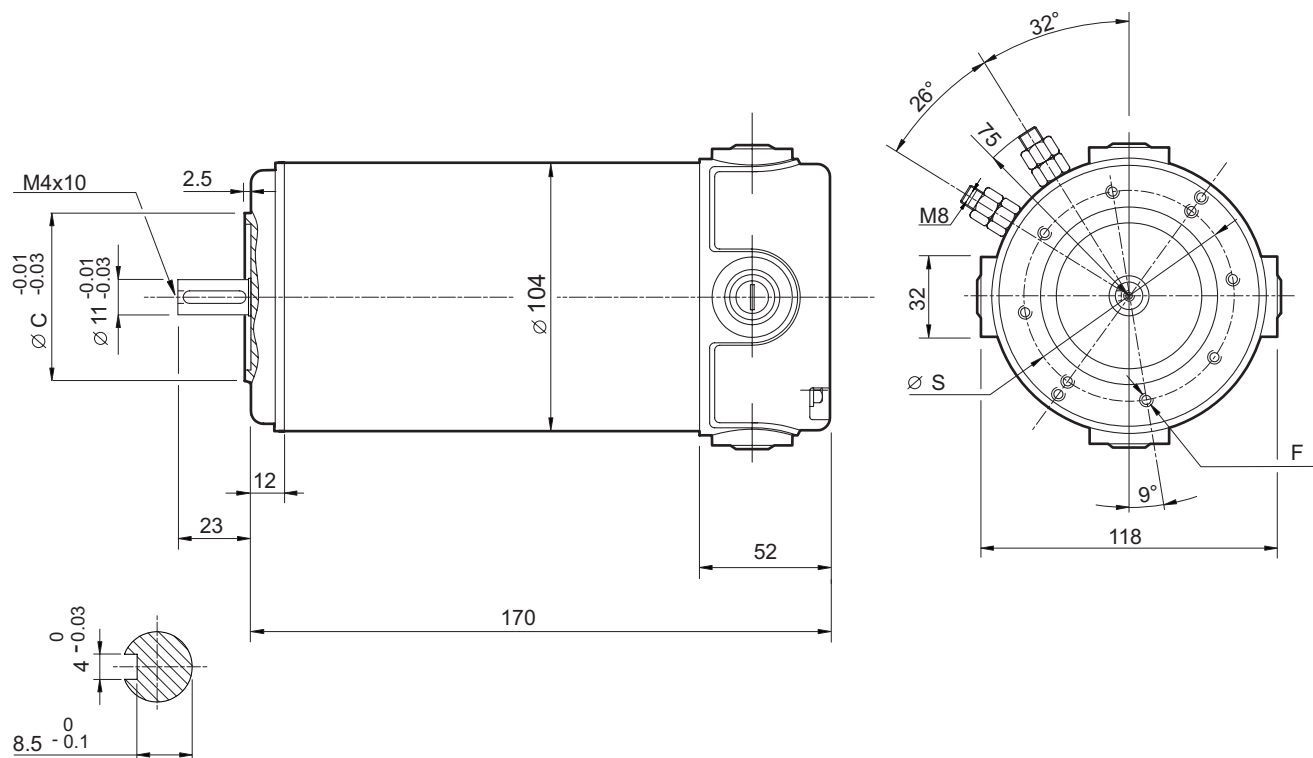

	63 B14	71 B14*
S	75	85
C (-0.01 / -0.03)	60	70
F	8 - M5	8 - M6

\* Usare boccola 11/14  
\* Use sleeve 11/14

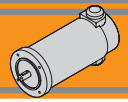

**EC250.120 - EC250.240**

Prestazioni

Performances

**EC250.120**

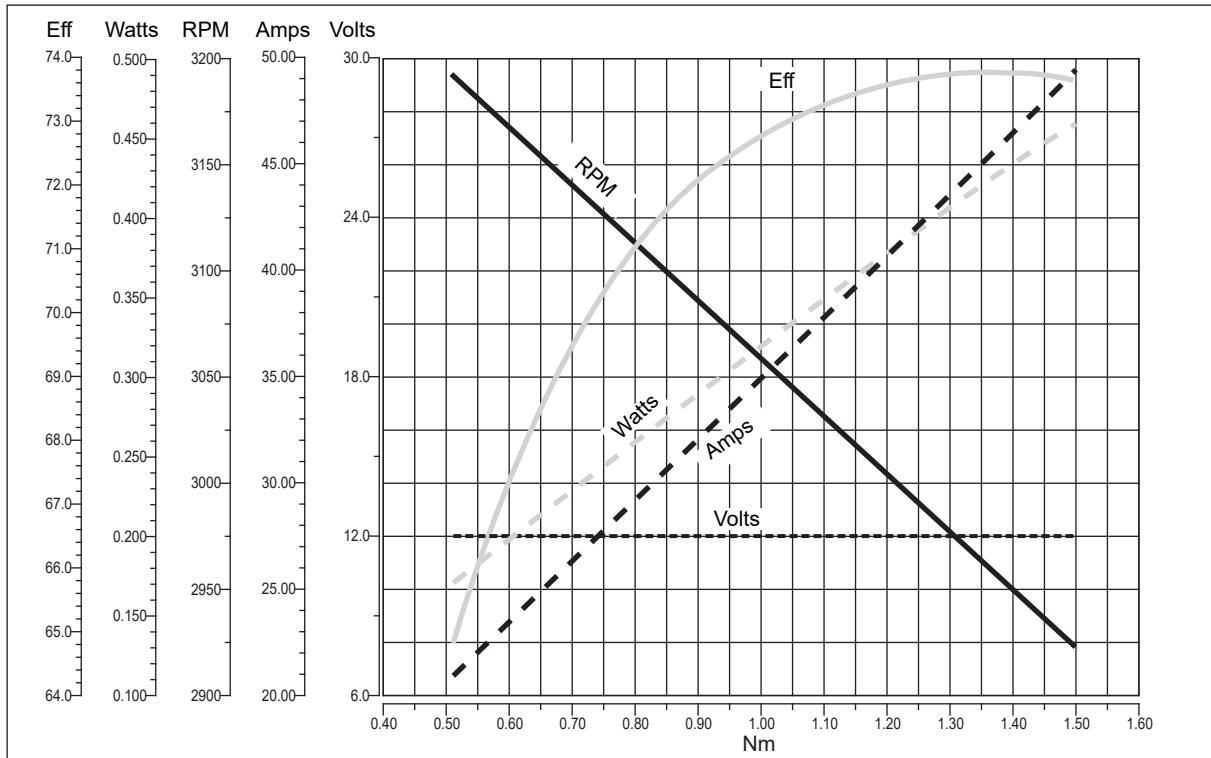

**EC250.240**

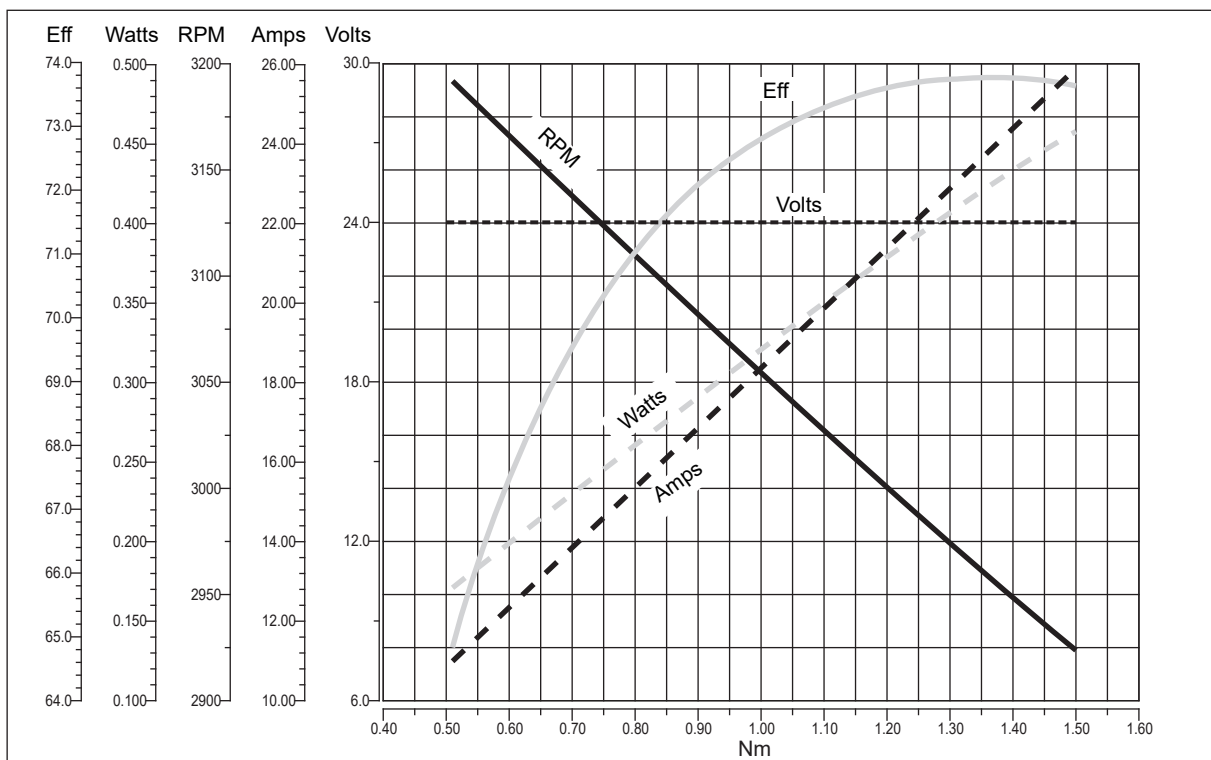

EC

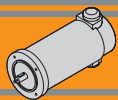

**EC350.120 - EC350.240**

**Caratteristiche**

**Features**

Costruzione	Tubolare, senza ventilazione
Grandezza	Ø 110 mm
Potenza	500 W S2 (350 W S1)
Magneti	4
Supporti	Cuscinetti a sfera
Fori di montaggio	8
Alimentazione	Bassa tensione, 12 o 24 Vcc
Spazzole	N° 4 di composto grafite-rame
Dimensione spazzole	LxPxH = 18.9 x 9.5 x 16.7 mm
Terminali	2 con dadi di fissaggio
Freno	Elettromagnetico

Construction	Tubular, without fan
Size	Ø 110 mm
Power	500 W S2 (350 W S1)
Magnets	4
Bearings	Ball bearings
Mounting holes	8
Power supply	Low voltage, 12 or 24 Vdc
Brushes	4 brushes made of graphite/copper composite
Brushes size	LxPxH = 18.9 x 9.5 x 16.7 mm
Leads terminals	2, with double nut
Brake	Electromagnetic

Tipo Type	S	Pn [W]	V [V]	I [A]	IC	FF	Mn [Nm]	n <sub>1</sub> [min <sup>-1</sup> ]	IP	Kg
EC350.120	S1	350	12	42	F	1	1.12	3000	40	5.1
	S2 30'	500		58.8			1.57			
EC350.240	S1	350	24	21			1.12		40	5.3
	S2 30'	500		29.4			1.57			

**Dimensioni**

**Dimensions**

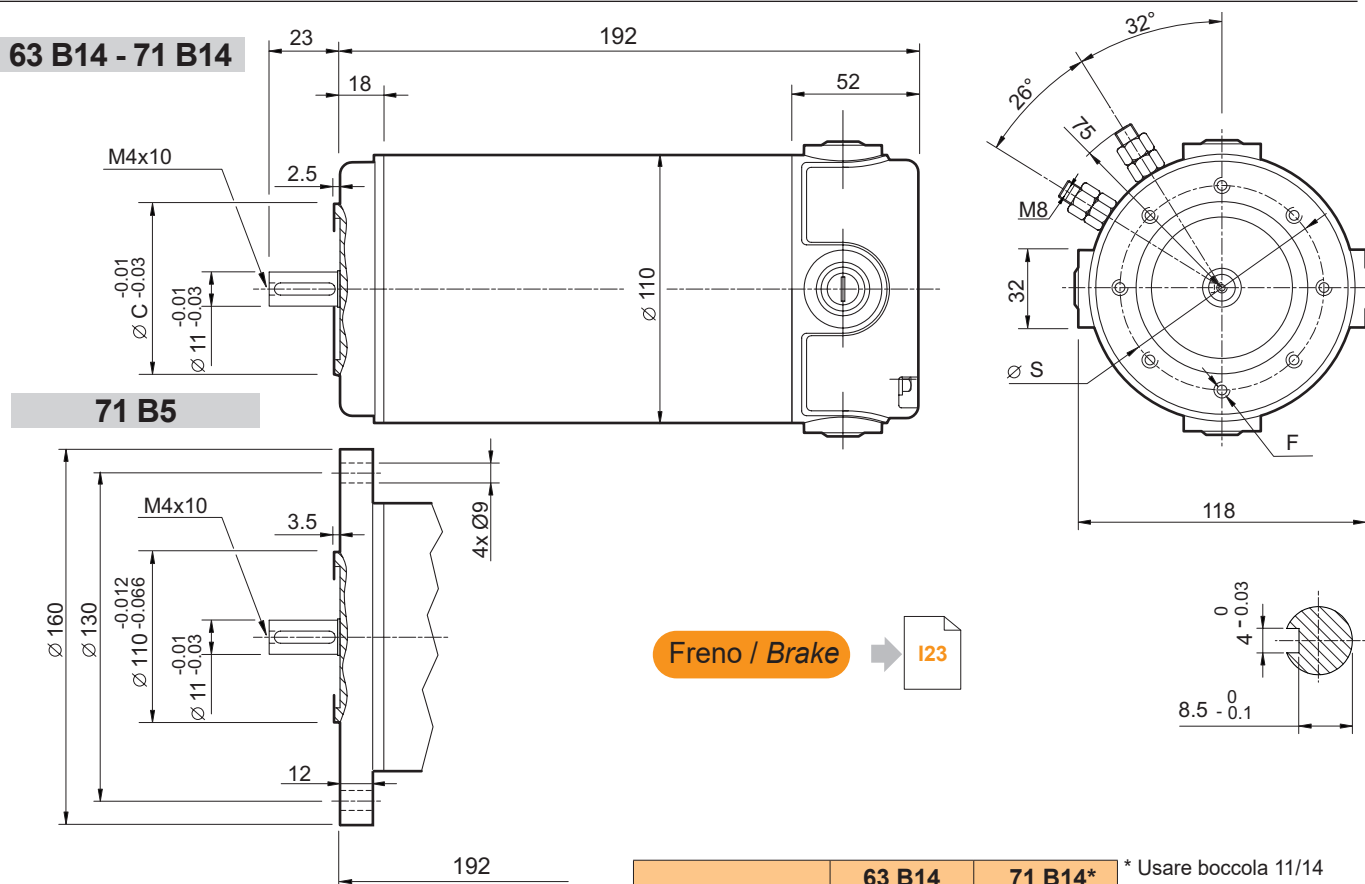

	63 B14	71 B14*
S	75	85
C (-0.01 / -0.03)	60	70
F	8 - M5	8 - M6

\* Usare boccola 11/14  
\* Use sleeve 11/14

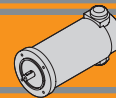

**EC350.120 - EC350.240**

Prestazioni

Performances

**EC350.120**

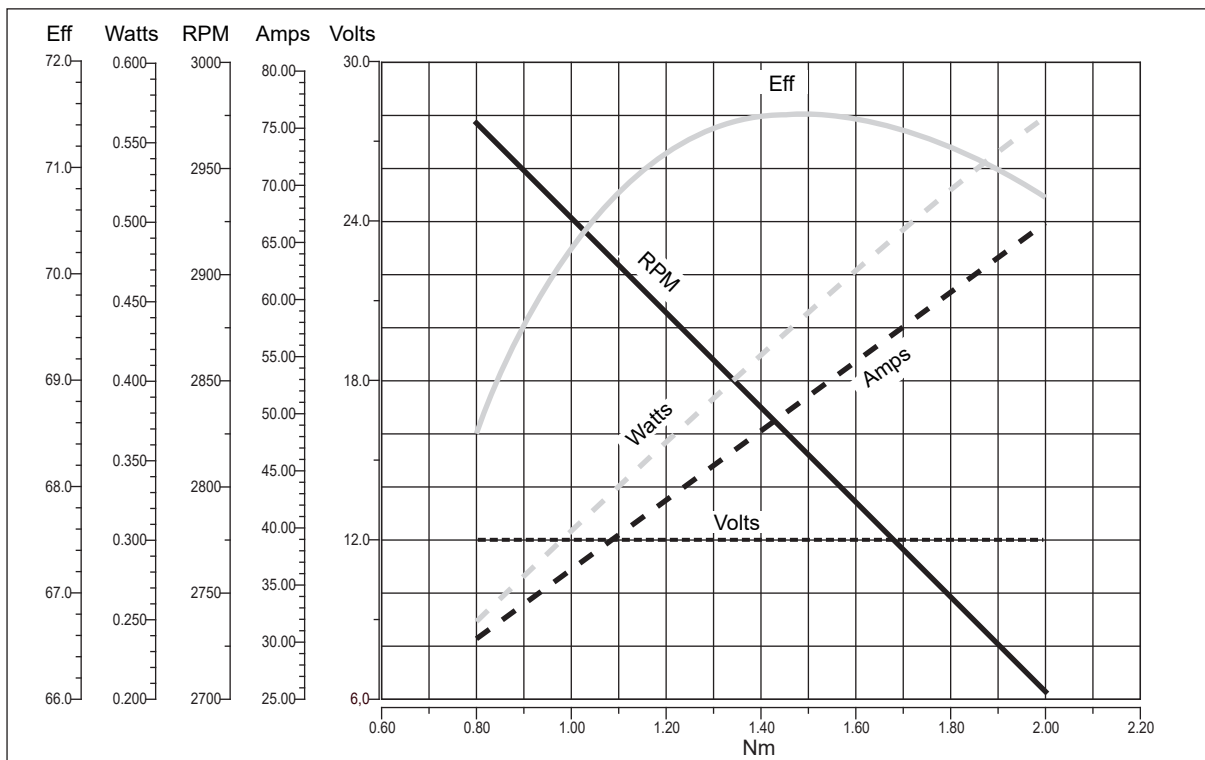

**EC350.240**

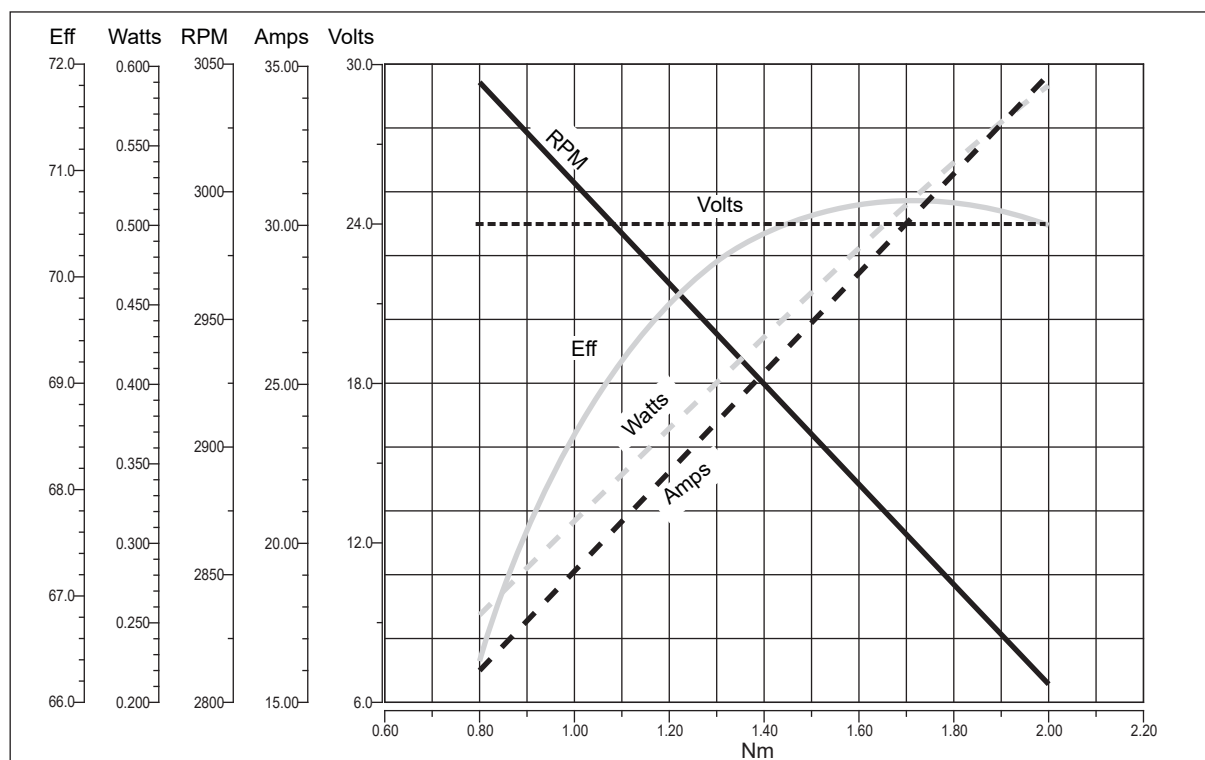

EC

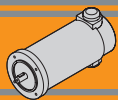

**EC600.120 - EC600.240**

**Caratteristiche**

**Features**

Costruzione	Tubolare, senza ventilazione
Grandezza	Ø 110 mm
Potenza	800 W S2 (600 W S1)
Magneti	4
Supporti	Cuscinetti a sfera
Fori di montaggio	8
Alimentazione	Bassa tensione, 12 o 24 Vcc
Spazzole	N° 4 di composto grafite-rame
Dimensione spazzole	LxPxH = 18.9 x 9.5 x 16.7 mm
Terminali	2 con doppio dado di fissaggio
Freno	Elettromagnetico

Construction	Tubular, without fan
Size	Ø 110 mm
Power	800 W S2 (600 W S1)
Magnets	4
Bearings	Ball bearings
Mounting holes	8
Power supply	Low voltage, 12 or 24 Vdc
Brushes	4 brushes made of graphite/copper composite
Brushes size	LxPxH = 18.9 x 9.5 x 16.7 mm
Leads terminals	2, with double nut
Brake	Electromagnetic

Tipo Type	S	Pn [W]	V [V]	I [A]	IC	FF	Mn [Nm]	n <sub>1</sub> [min <sup>-1</sup> ]	IP	Kg
EC600.120	S1	600	12	71	F	1	1.91	3000	40	6.6
	S2 30'	800		94.4			2.54			
EC600.240	S1	600	24	35.5			1.91		40	7.1
	S2 30'	800		47.2			2.54			

**Dimensioni**

**Dimensions**

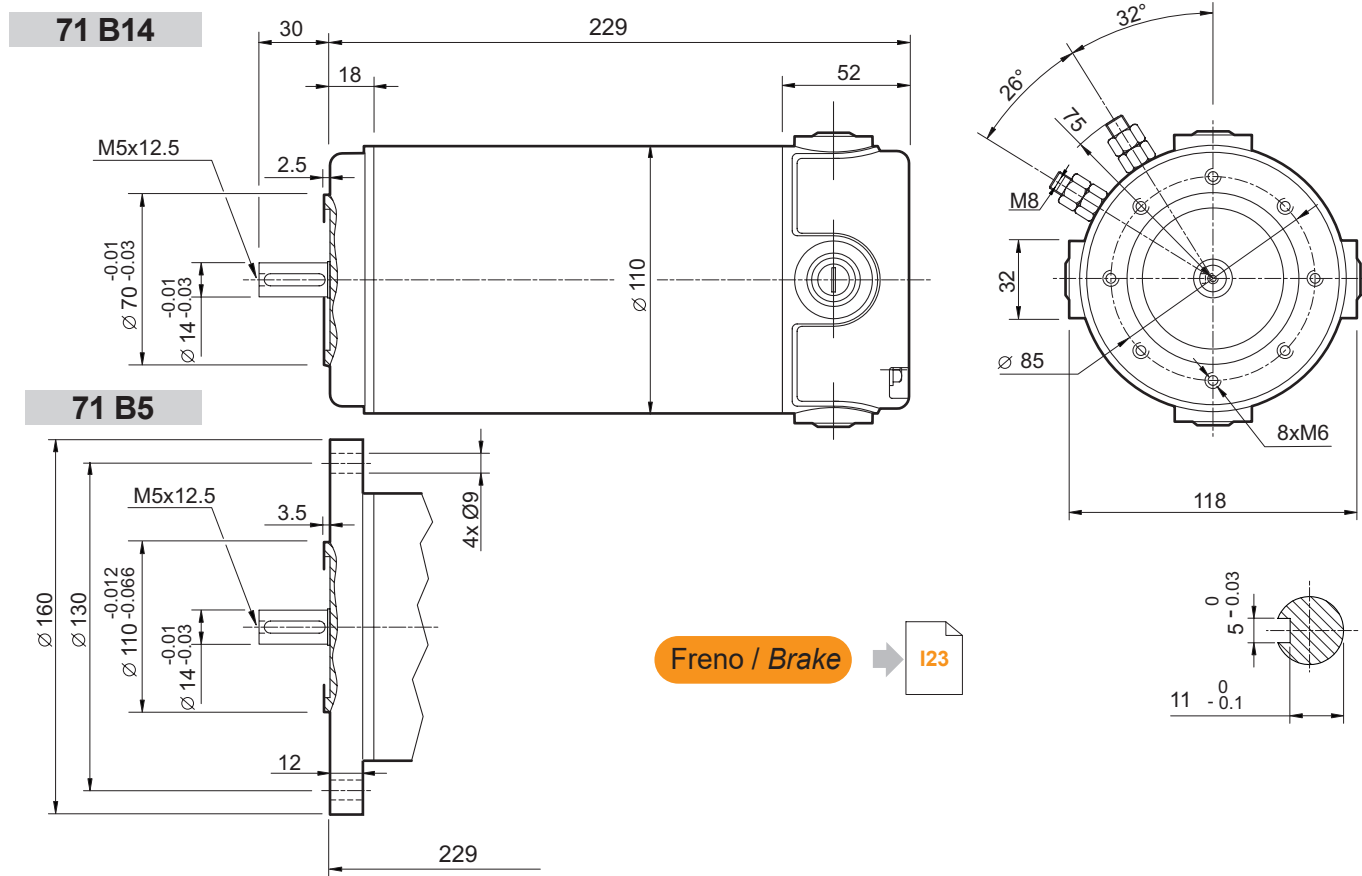

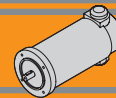

**EC600.120 - EC600.240**

Prestazioni

Performances

**EC600.120**

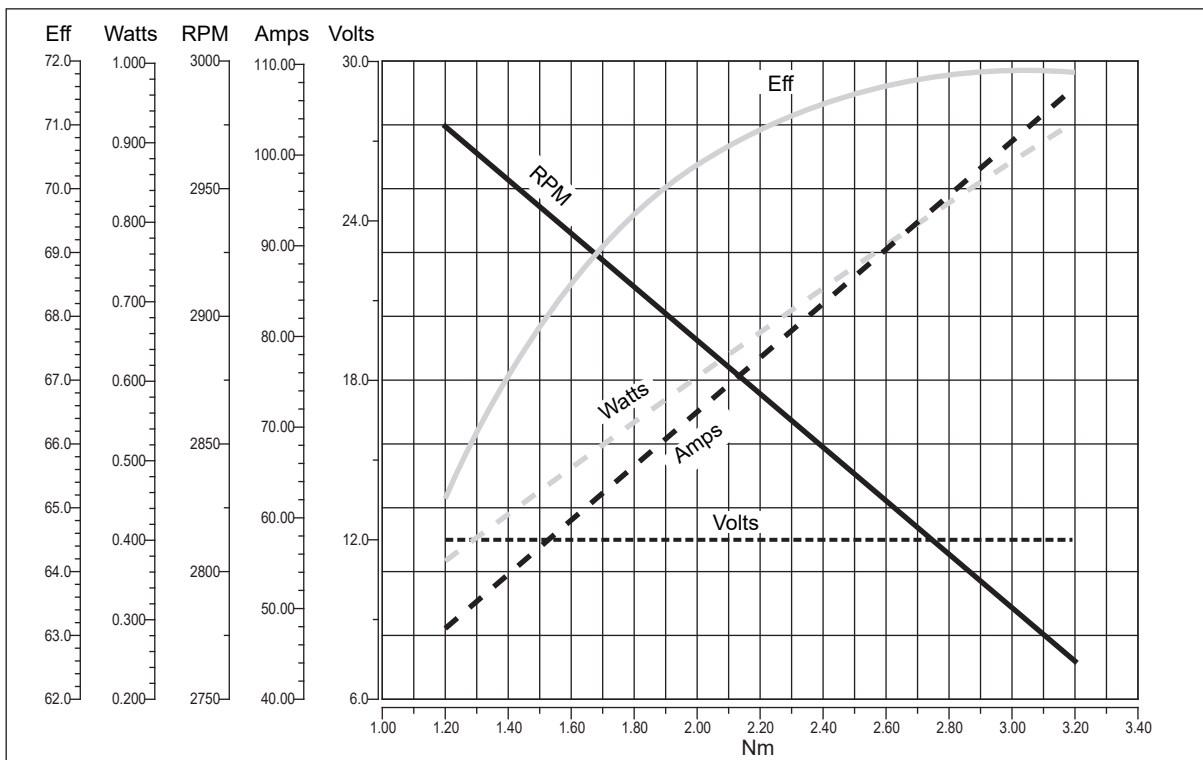

**EC600.240**

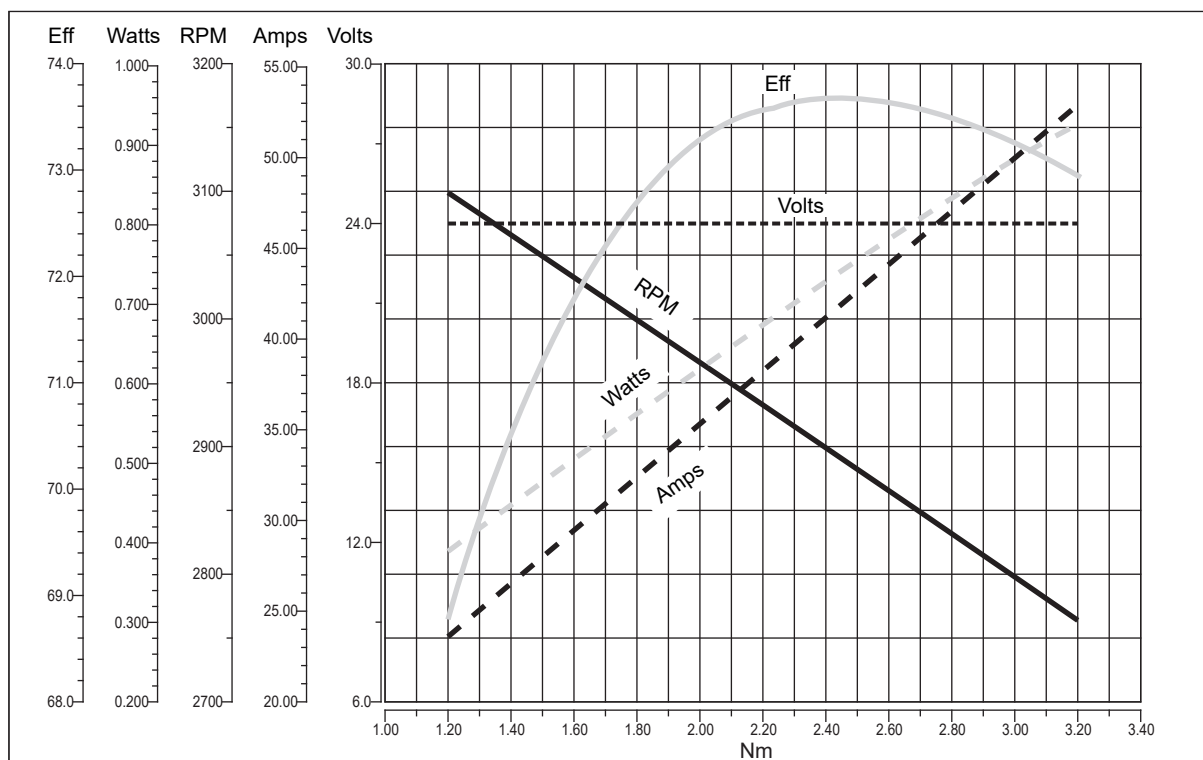

EC

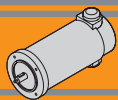

**Legenda / Glossario dei grafici**

**Key / Diagram Glossary**

Dato un motore in C.C, la velocità di rotazione è funzione lineare della coppia; così pure la corrente assorbita è una funzione lineare della coppia. Velocità e corrente variano in maniera sensibile al variare del carico.

With a D.C. motor, the rotational speed is a linear function of the torque. In the same way, the absorbed current is also a linear function of the torque. Speed and current change a lot against applied torque.

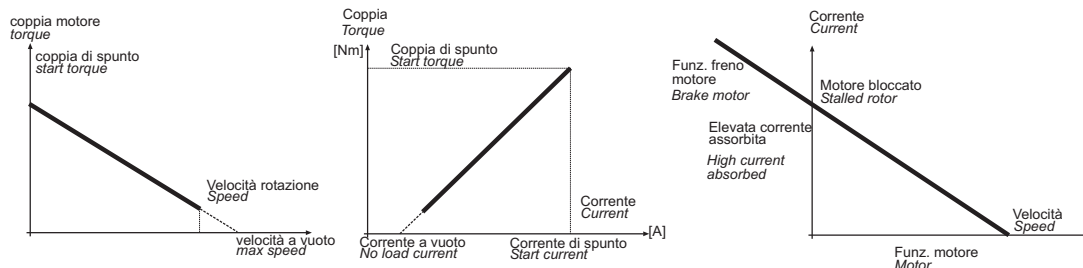

La potenza utile (potenza all' albero) si ricava dalla formula:

$$P_n [W] = M_n \cdot S = \frac{2\pi}{60} \cdot n_1 \cdot M_n$$

The output power is calculated using the formula:

$$P_n [W] = M_n \cdot S = \frac{2\pi}{60} \cdot n_1 \cdot M_n$$

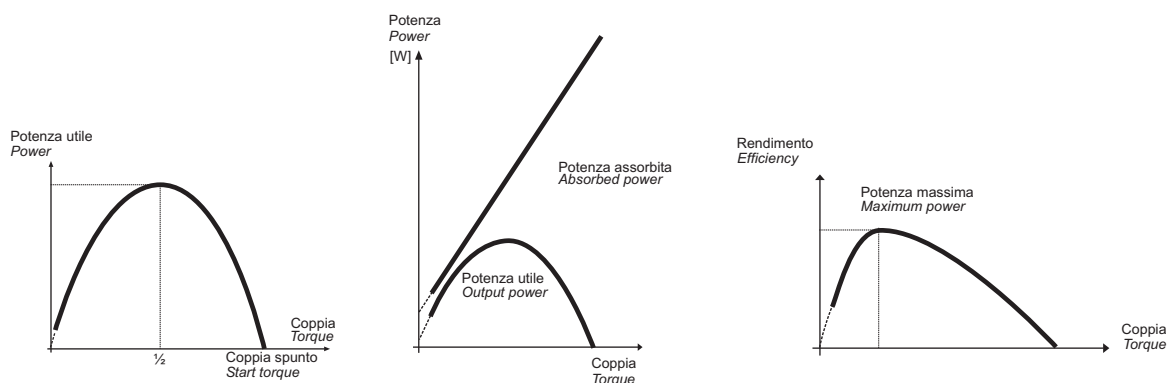

Poiché la tensione di alimentazione è costante mentre la corrente è linearmente crescente al crescere della coppia, l'andamento della potenza assorbita è un retta crescente. Dal rapporto tra la potenza meccanica e la potenza assorbita si ottiene il grafico dell'efficienza.

Since the supply voltage is constant, whereas the current increases in a linear manner as the torque increases, the absorbed power trend is a straight line going up. Efficiency is shown from the ratio between the output power and the absorbed power.

**Formule utili**

**Useful formulas**

$$\eta = \frac{P_n}{P_a}$$

$$P_a = V \cdot I$$

$$P_n = V \cdot I \cdot \eta$$

$$P_n = M_n \cdot S_v$$

$$S_v = \frac{n_1}{9.55}$$

$$[HP] \cdot 746 = [W].$$

Esempio 2 HP = circa 1500 W.

$$\eta = \frac{P_n}{P_a}$$

$$P_a = V \cdot I$$

$$P_n = V \cdot I \cdot \eta$$

$$P_n = M_n \cdot S_v$$

$$S_v = \frac{n_1}{9.55}$$

$$[HP] \cdot 746 = [W].$$

Example 2 HP = approx. 1500 W.

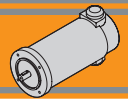

Freno

Brake

Freno / Brake

Freno con leva di sblocco/ Brake with hand release

EC050...BR  
EC070...BR

EC050...BRL  
EC070...BRL

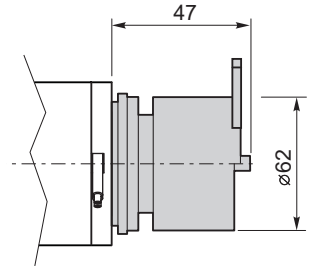
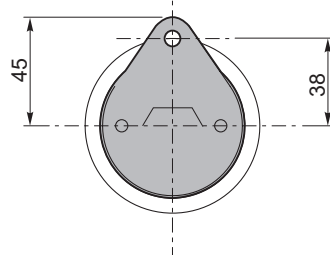
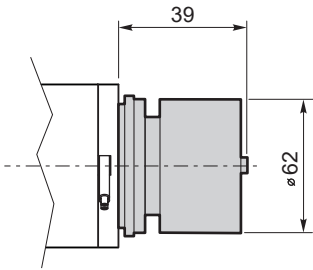

	Pn [W]	V [V]	Mn [Nm]	n <sub>1</sub> [min <sup>-1</sup> ]
Caratteristiche del freno / Break features	14	12 24	1.8	3000

EC100.24E BR  
EC180.24E BR

EC100.24E BRL  
EC180.24E BRL

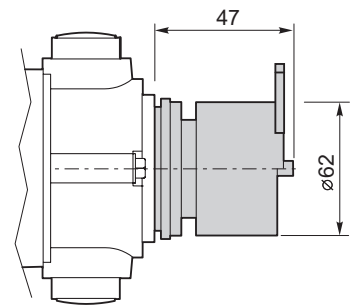
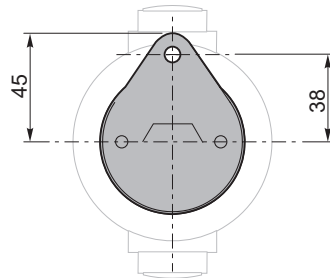
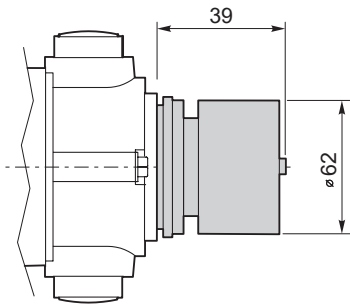

	Pn [W]	V [V]	Mn [Nm]	n <sub>1</sub> [min <sup>-1</sup> ]
Caratteristiche del freno / Break features	14	12 24	1.8	3000

EC350...BR  
EC600...BR

EC350...BRL  
EC600...BRL

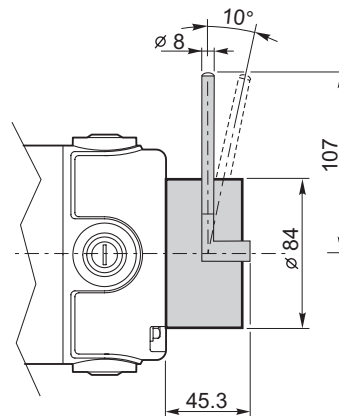
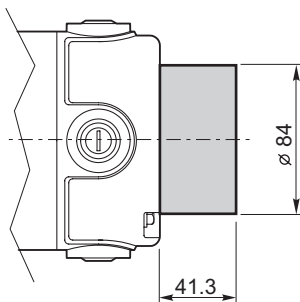

	Pn [W]	V [V]	Mn [Nm]	n <sub>1</sub> [min <sup>-1</sup> ]
Caratteristiche del freno / Break features	25	12 24	5	3000

EC

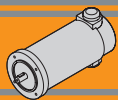

**Encoder**

**Encoder**

**EC020.24E ME22**

**EC050.12E ME22**

**EC050.24E ME22**

**EC070.12E ME22**

**EC070.24E ME22**

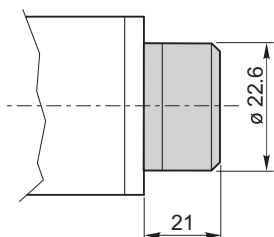

**EC100.24E ME22**

**EC180.24E ME22**

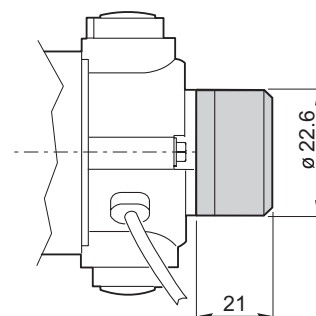

Risoluzione Encoder (CPR) / Encoder Resolution (CPR)	Numero di canali / Number of channels	Tensione d'alimentazione / Power supply
001	2	5 VdC - TTL
100		
300		

Per risoluzioni encoder non standard, si prega di contattare il nostro Servizio Tecnico.

*For non-standard encoder resolution, please contact our Technical Department.*

Nota: Fornito con cavo lungo 300 mm

*Note: Supplie with cavle 300 mm long*

**TRANSTECNO**<sup>®</sup>  
the modular gearmotor

**EC IP66**

EC IP66



Ferrite

**Motori elettrici CC IP66**  
**IP66 DC electric motors**





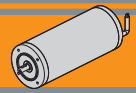

	<b>Indice</b>	<b>Index</b>	<b>Pag. Page</b>
<b>EC070.120.66</b> <b>EC070.240.66</b>	Caratteristiche	<i>Features</i>	<b>L2</b>
	Dimensioni	<i>Dimensions</i>	<b>L2</b>
	Prestazioni	<i>Performances</i>	<b>L3</b>
<b>EC100.120.66</b> <b>EC100.240.66</b>	Caratteristiche	<i>Features</i>	<b>L4</b>
	Dimensioni	<i>Dimensions</i>	<b>L4</b>
	Prestazioni	<i>Performances</i>	<b>L5</b>
<b>EC180.120.66</b> <b>EC180.240.66</b>	Caratteristiche	<i>Features</i>	<b>L6</b>
	Dimensioni	<i>Dimensions</i>	<b>L6</b>
	Prestazioni	<i>Performances</i>	<b>L7</b>
<b>EC250.120.66</b> <b>EC250.240.66</b>	Caratteristiche	<i>Features</i>	<b>L8</b>
	Dimensioni	<i>Dimensions</i>	<b>L8</b>
	Prestazioni	<i>Performances</i>	<b>L9</b>
<b>EC350.120.66</b> <b>EC350.240.66</b>	Caratteristiche	<i>Features</i>	<b>L10</b>
	Dimensioni	<i>Dimensions</i>	<b>L10</b>
	Prestazioni	<i>Performances</i>	<b>L11</b>
<b>EC600.120.66</b> <b>EC600.240.66</b>	Caratteristiche	<i>Features</i>	<b>L12</b>
	Dimensioni	<i>Dimensions</i>	<b>L12</b>
	Prestazioni	<i>Performances</i>	<b>L13</b>

Questa sezione annulla e sostituisce ogni precedente edizione o revisione. Qualora questa sezione non Vi sia giunta in distribuzione controllata, l'aggiornamento dei dati ivi contenuto non è assicurato. **In tal caso la versione più aggiornata è disponibile sul nostro sito internet [www.transtecno.com](http://www.transtecno.com)**

*This section replaces any previous edition and revision. If you obtained this catalogue other than through controlled distribution channels, the most up to date content is not guaranteed. **In this case the latest version is available on our web site [www.transtecno.com](http://www.transtecno.com)***



## EC070.120.66 - EC070.240.66

### Caratteristiche

### Features

Costruzione	Tubolare, senza ventilazione
Grandezza	Ø 65 mm
Potenza	100 W S2 (70 W S1)
Magneti	2
Supporti	Cuscinetti a sfera
Fori di montaggio	4
Alimentazione	Bassa tensione, 12 o 24 Vcc
Spazzole	N° 2 interne di composto grafite-rame
Cavo di alimentazione	Lunghezza: 1000 mm

Construction	Tubular, without fan
Size	Ø 65 mm
Power	100 W S2 (70 W S1)
Magnets	2
Bearings	Ball bearings
Mounting holes	4
Power supply	Low voltage, 12 or 24 Vdc
Brushes	2 inside brushes made of graphite/copper composite
Electric cable	Length: 1000 mm

Tipo Type	S	Pn [W]	V [V]	I [A]	IC	FF	Mn [Nm]	n <sub>1</sub> [min <sup>-1</sup> ]	IP	Kg
EC070.120.66	S1	70	12	8.4	F	1	0.22	3000	66	1.7
	S2 30'	100		11.8			0.31			
EC070.240.66	S1	70	24	4.2			0.22			
	S2 30'	100		5.9			0.31			

### Dimensioni

### Dimensions

#### EC070.120.66 EC070.240.66

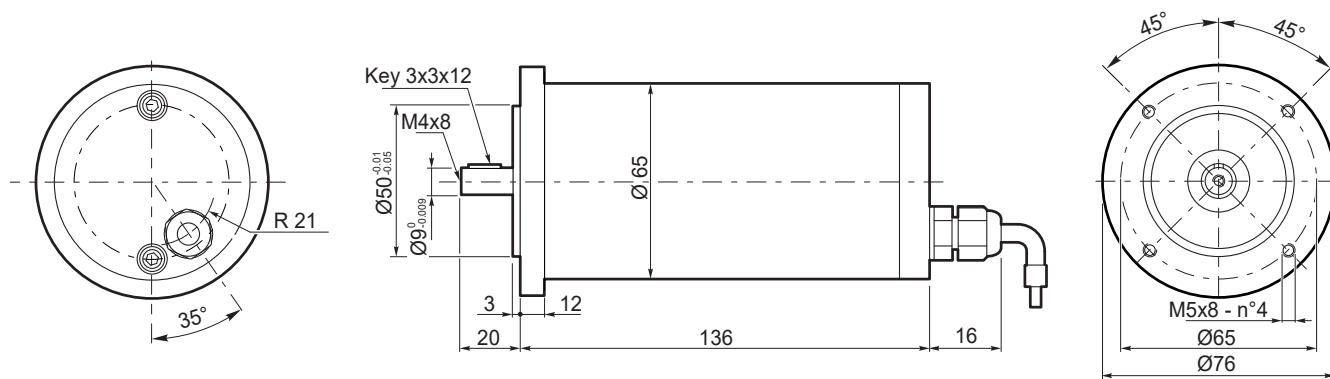



**EC070.120.66 - EC070.240.66**

Prestazioni

Performances

**EC070.120.66**

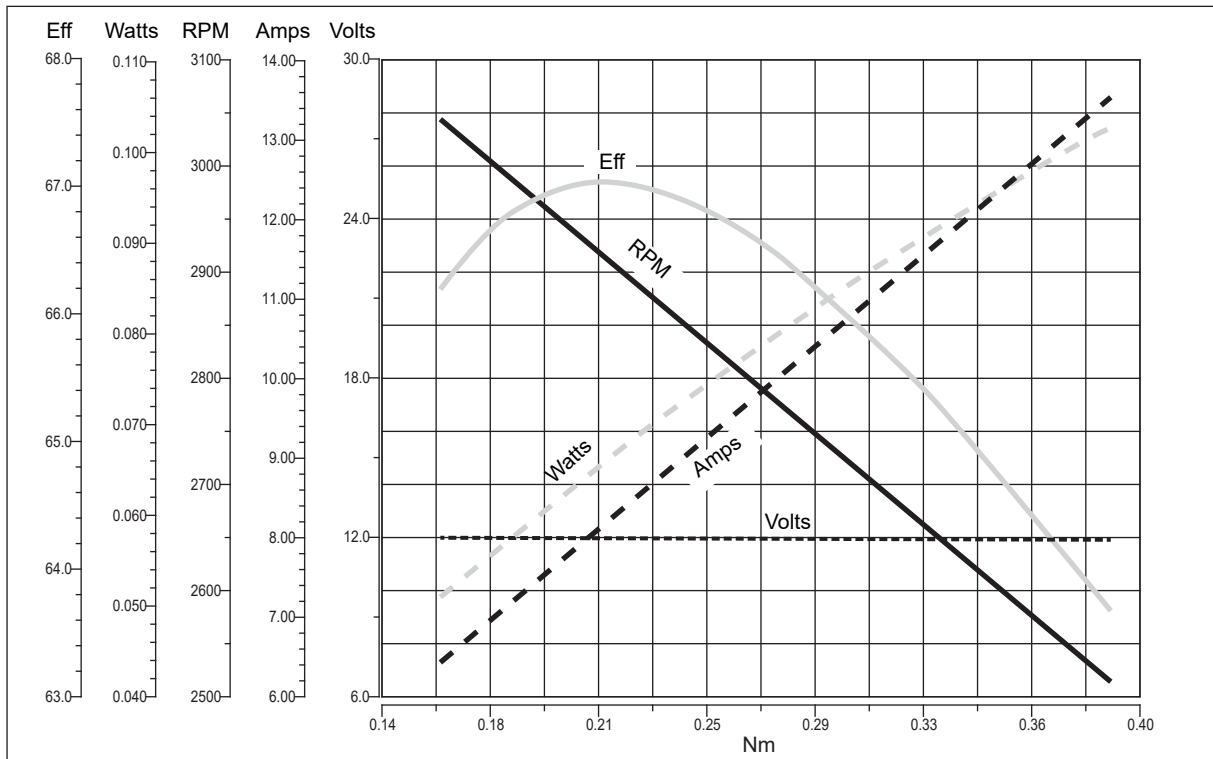

**EC070.240.66**

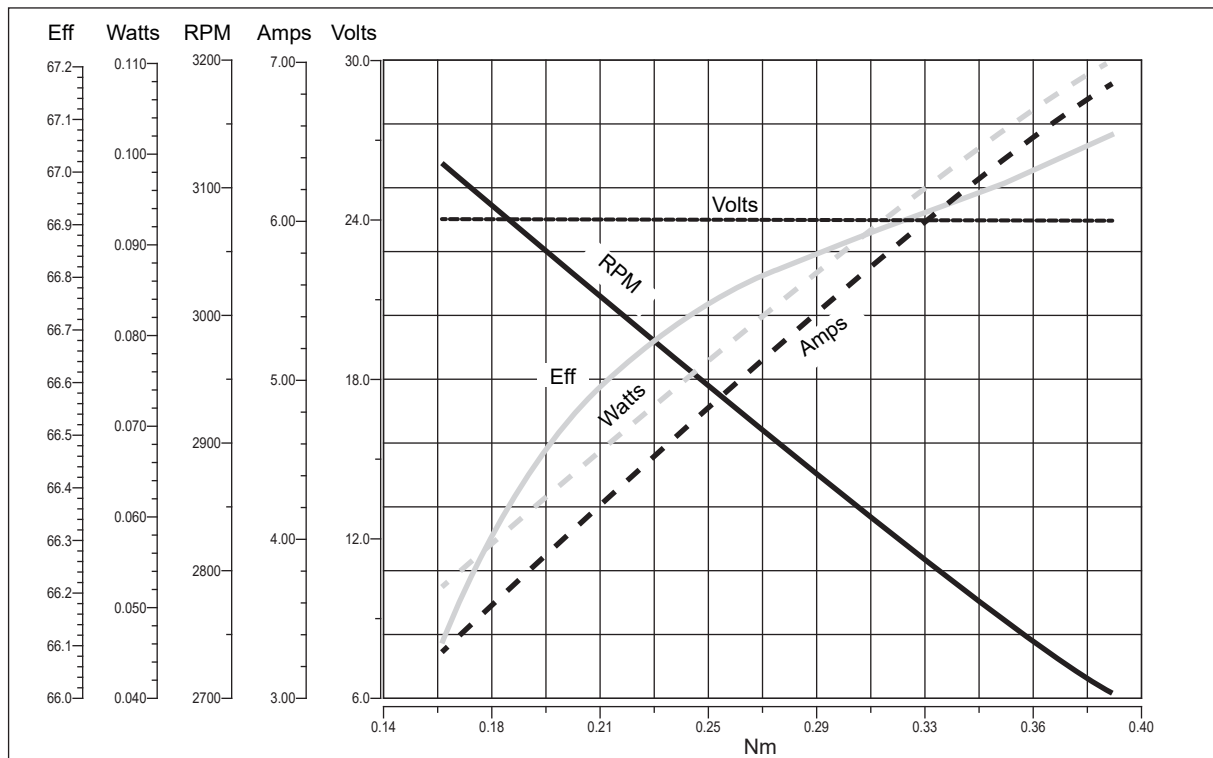

EC IP66

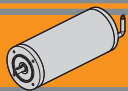

**EC100.120.66 - EC100.240.66**

**Caratteristiche**

**Features**

Costruzione	Tubolare, senza ventilazione
Grandezza	Ø 80 mm
Potenza	140 W S2 (100 W S1)
Magneti	2
Supporti	Cuscinetti a sfera
Fori di montaggio	4
Alimentazione	Bassa tensione, 12 o 24 Vcc
Cavo di alimentazione	Lunghezza: 1000 mm

Construction	Tubular, without fan
Size	Ø 80 mm
Power	140 W S2 (100 W S1)
Magnets	2
Bearings	Ball bearings
Mounting holes	4
Power supply	Low voltage, 12 or 24 Vdc
Electric cable	Length: 1000 mm

Tipo Type	S	Pn [W]	V [V]	I [A]	IC	FF	Mn [Nm]	n <sub>1</sub> [min <sup>-1</sup> ]	IP	Kg
EC100.120.66	S1	100	12	12	F	1	0.31	3000	66	2.7
	S2 25'	140		16.8			0.43			
EC100.240.66	S1	100	24	6			0.31			
	S2 25'	140		8.4			0.43			

**Dimensioni**

**Dimensions**

**EC100.120.66**  
**EC100.240.66**

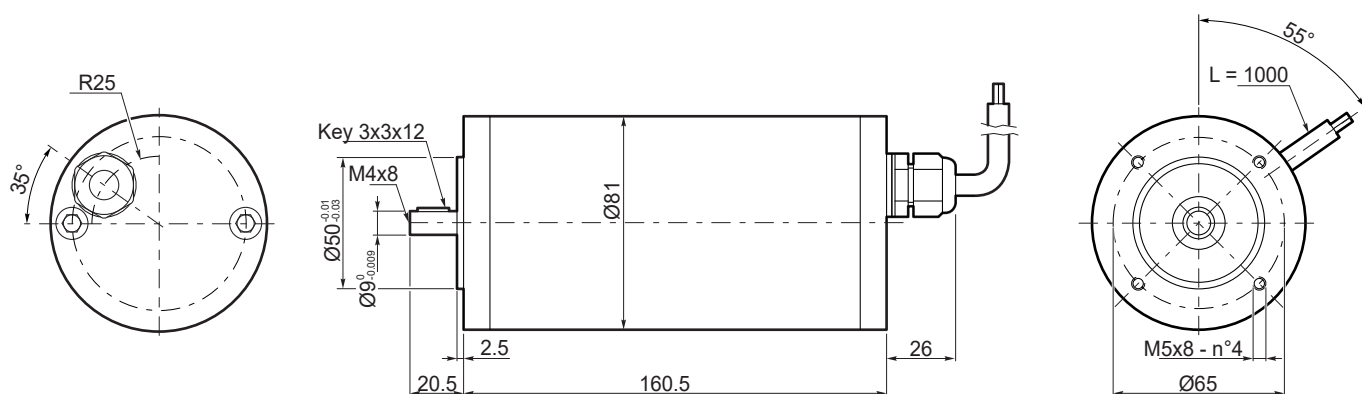



**EC100.120.66**

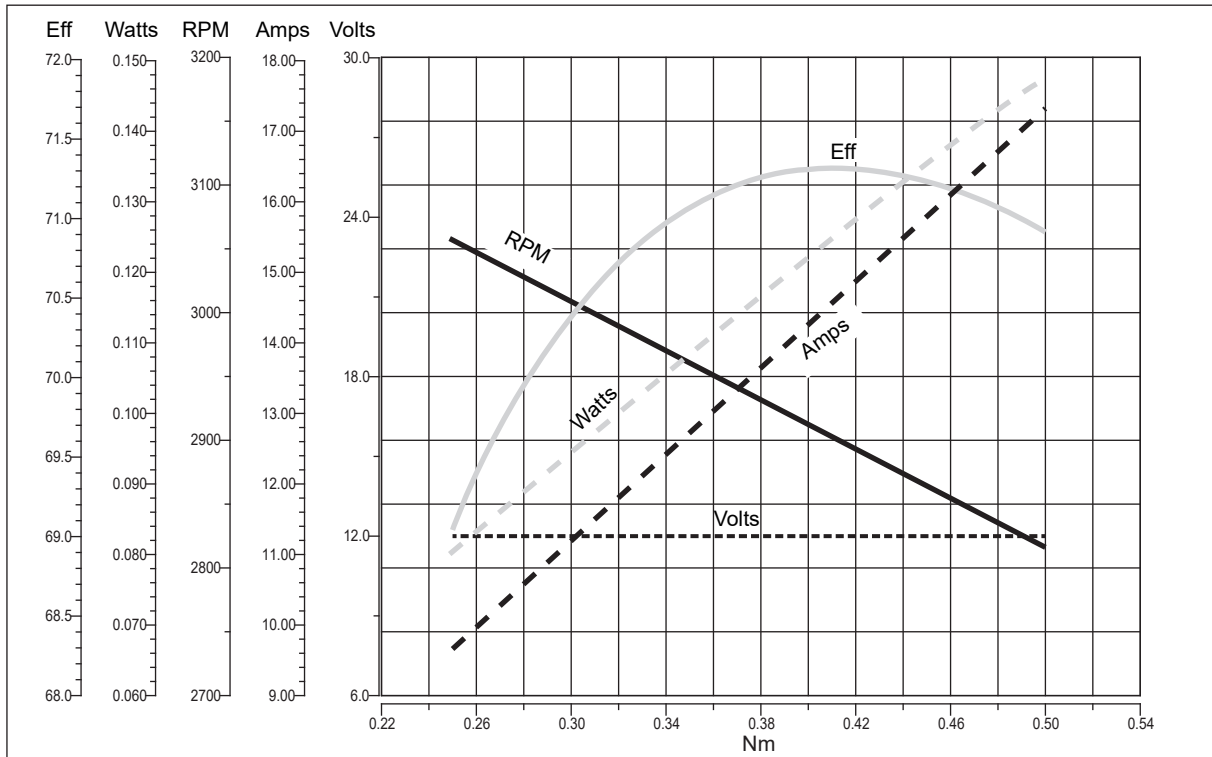

**EC100.240.66**

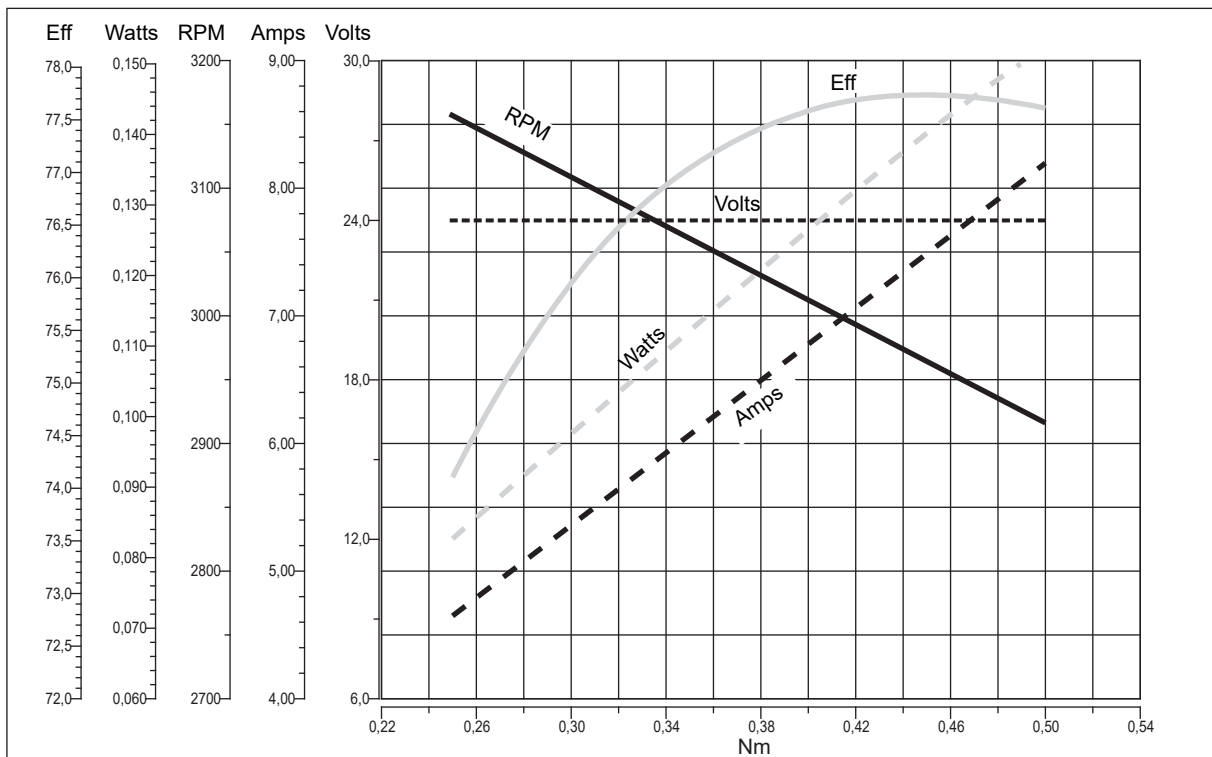

EC IP66

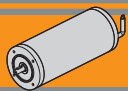

## EC180.120.66 - EC180.240.66

### Caratteristiche

### Features

Costruzione	Tubolare, senza ventilazione
Grandezza	Ø 80 mm
Potenza	250 W S2 (180 W S1)
Magneti	2
Supporti	Cuscinetti a sfera
Fori di montaggio	4
Alimentazione	Bassa tensione, 12 o 24 Vcc
Cavo di alimentazione	Lunghezza: 1000 mm

Construction	Tubular, without fan
Size	Ø 80 mm
Power	250 W S2 (180 W S1)
Magnets	2
Bearings	Ball bearings
Mounting holes	4
Power supply	Low voltage, 12 or 24 Vdc
Electric cable	Length: 1000 mm

Tipo Type	S	Pn [W]	V [V]	I [A]	IC	FF	Mn [Nm]	n <sub>1</sub> [min <sup>-1</sup> ]	IP	Kg
EC180.120.66	S1	180	12	21.5	F	1	0.57	3000	66	3.4
	S2 25'	250		30			0.8			
EC180.240.66	S1	180	24	10.8			0.57			
	S2 25'	250		15			0.8			

### Dimensioni

### Dimensions

#### EC180.120.66 EC180.240.66

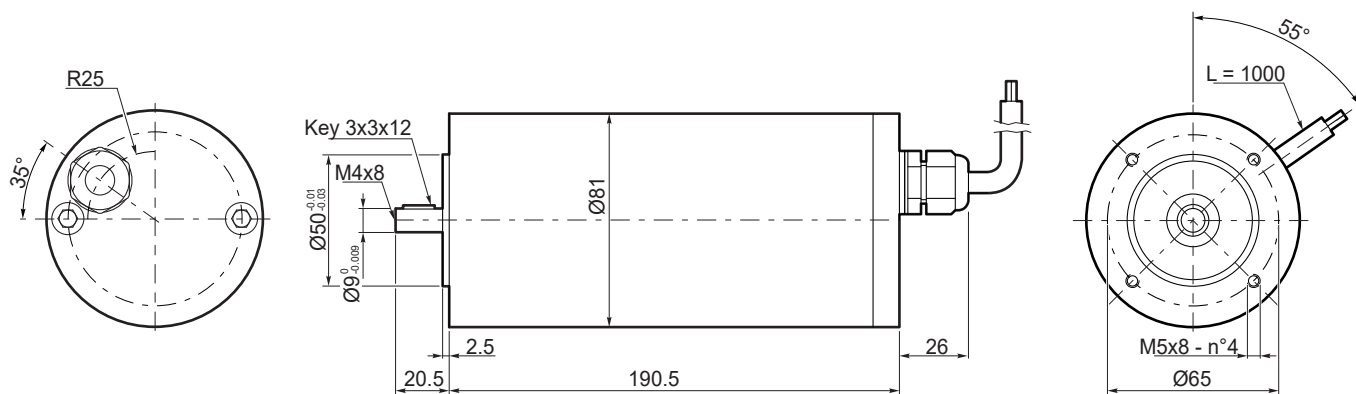



**EC180.120.66**

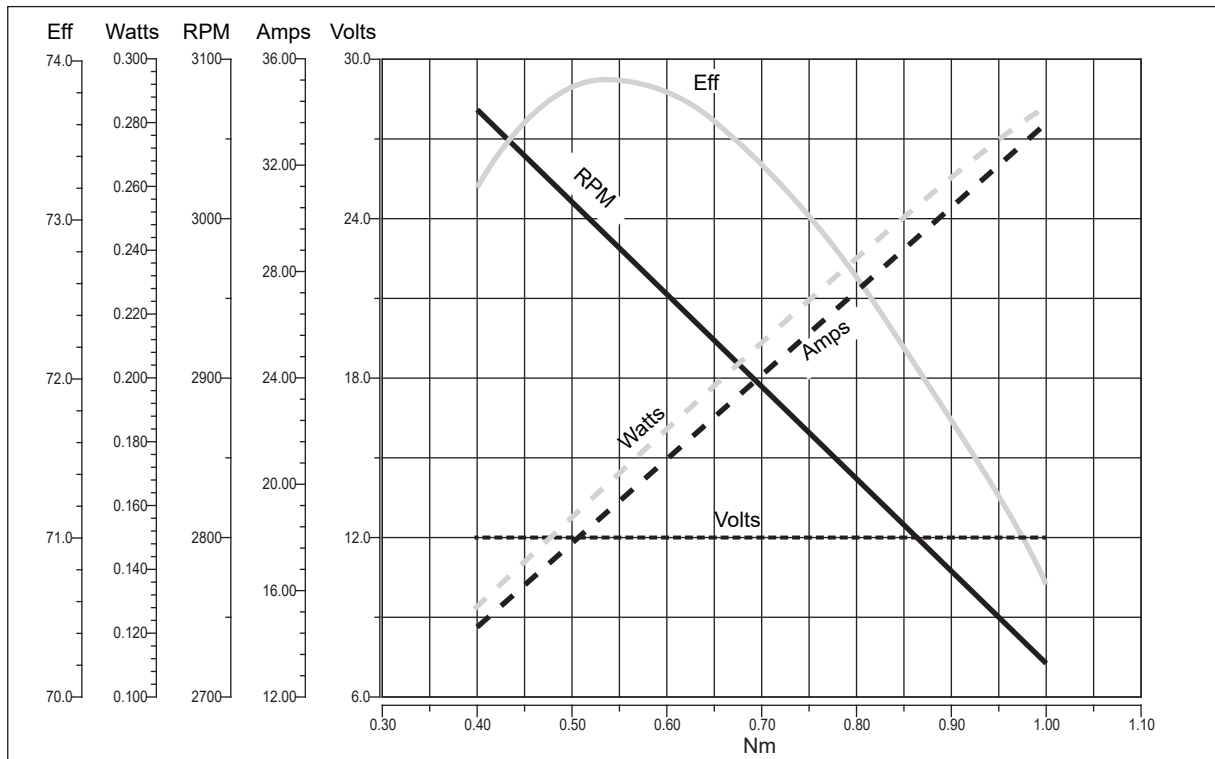

**EC180.240.66**

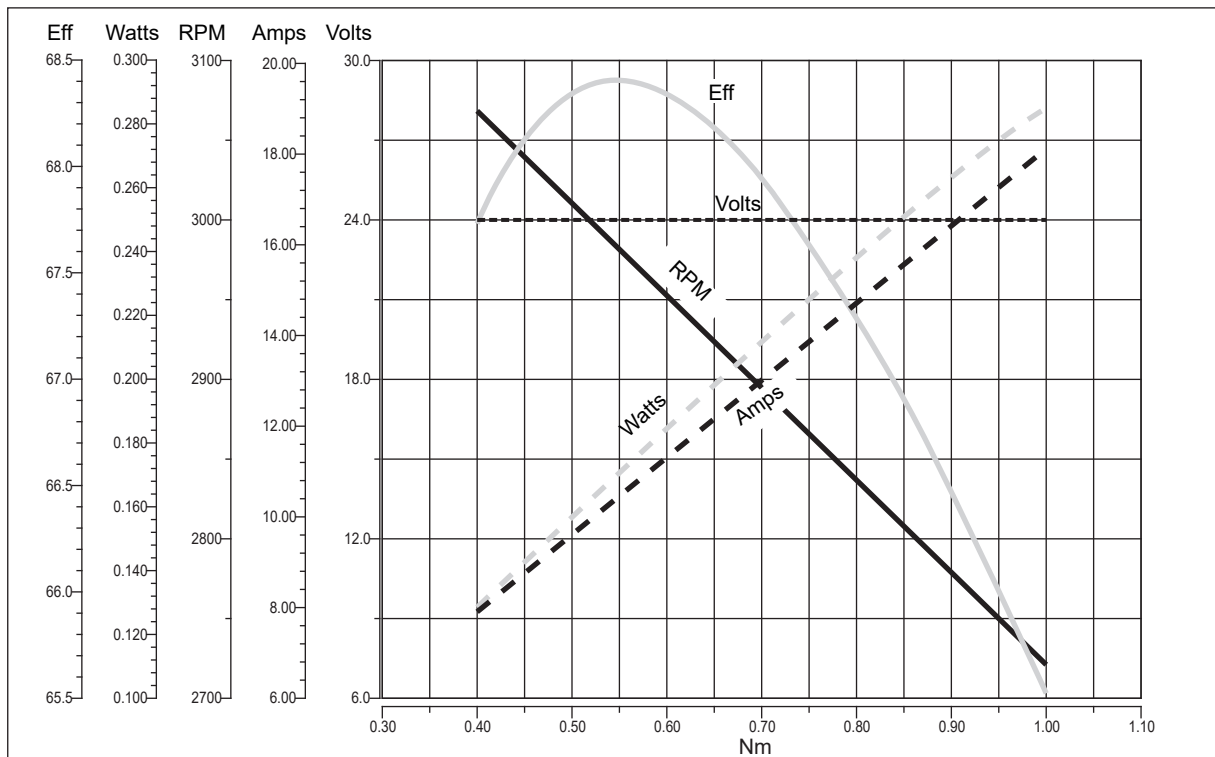

EC IP66



## EC250.120.66 - EC250.240.66

### Caratteristiche

### Features

Costruzione	Tubolare, senza ventilazione
Grandezza	Ø 104 mm
Potenza	350 W S2 (250 W S1)
Magneti	4
Supporti	Cuscinetti a sfera
Fori di montaggio	8
Alimentazione	Bassa tensione, 12 o 24 Vcc
Terminali	2 con doppio dado di fissaggio

Construction	Tubular, without fan
Size	Ø 104 mm
Power	350 W S2 (250 W S1)
Magnets	4
Bearings	Ball bearings
Mounting holes	8
Power supply	Low voltage, 12 or 24 Vdc
Leads terminals	2, with double nut

Tipo Type	S	Pn [W]	V [V]	I [A]	IC	FF	Mn [Nm]	n <sub>1</sub> [min <sup>-1</sup> ]	IP	Kg
EC250.120.66	S1	250	12	30	F	1	0.8	3000	66	4.15
	S2 25'	350		38.5			1.12			
EC250.240.66	S1	250	24	15			0.8			
	S2 25'	350		20.5			1.12			

### Dimensioni

### Dimensions

#### EC250.120.66

#### EC250.240.66

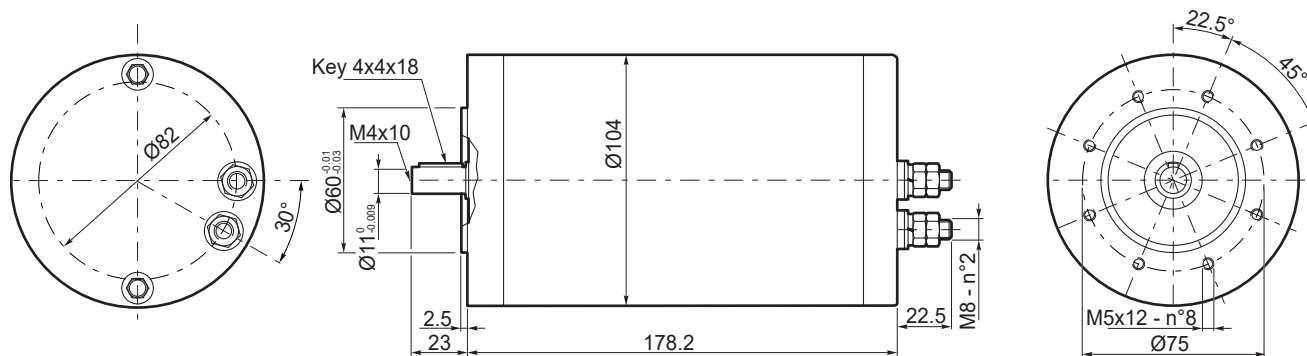



**EC250.120.66**

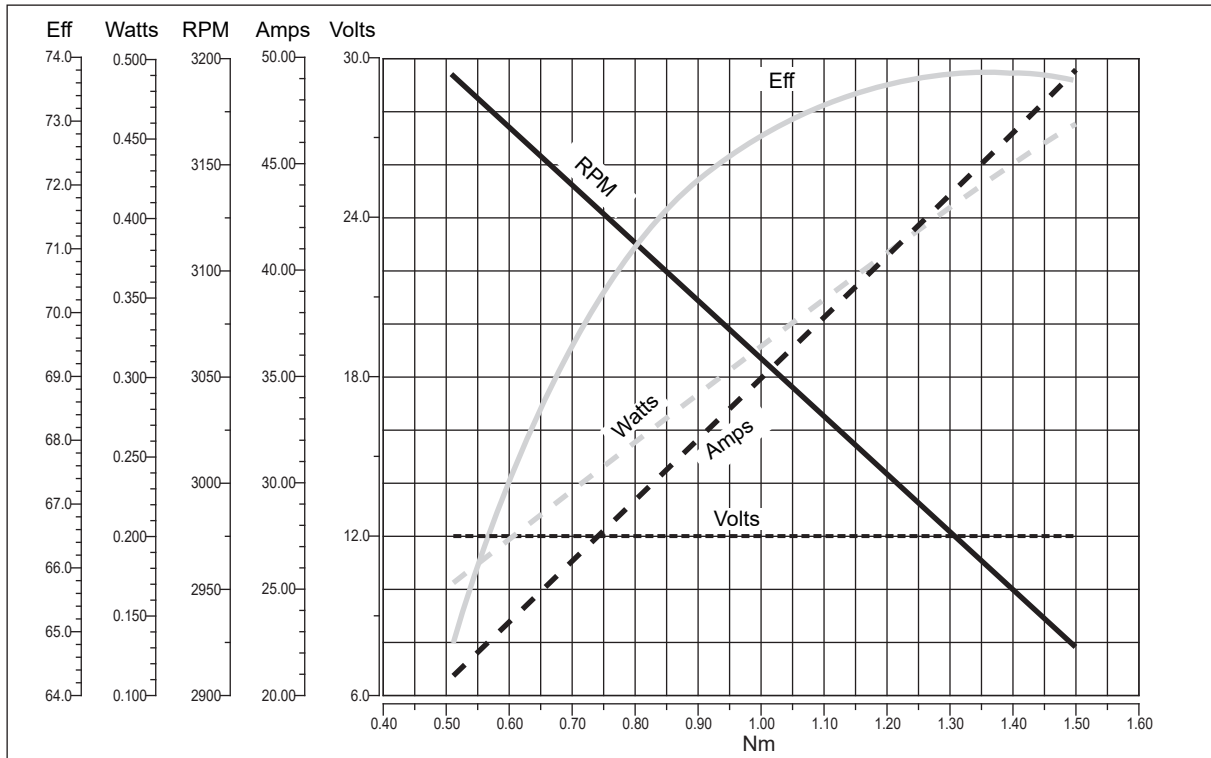

**EC250.240.66**

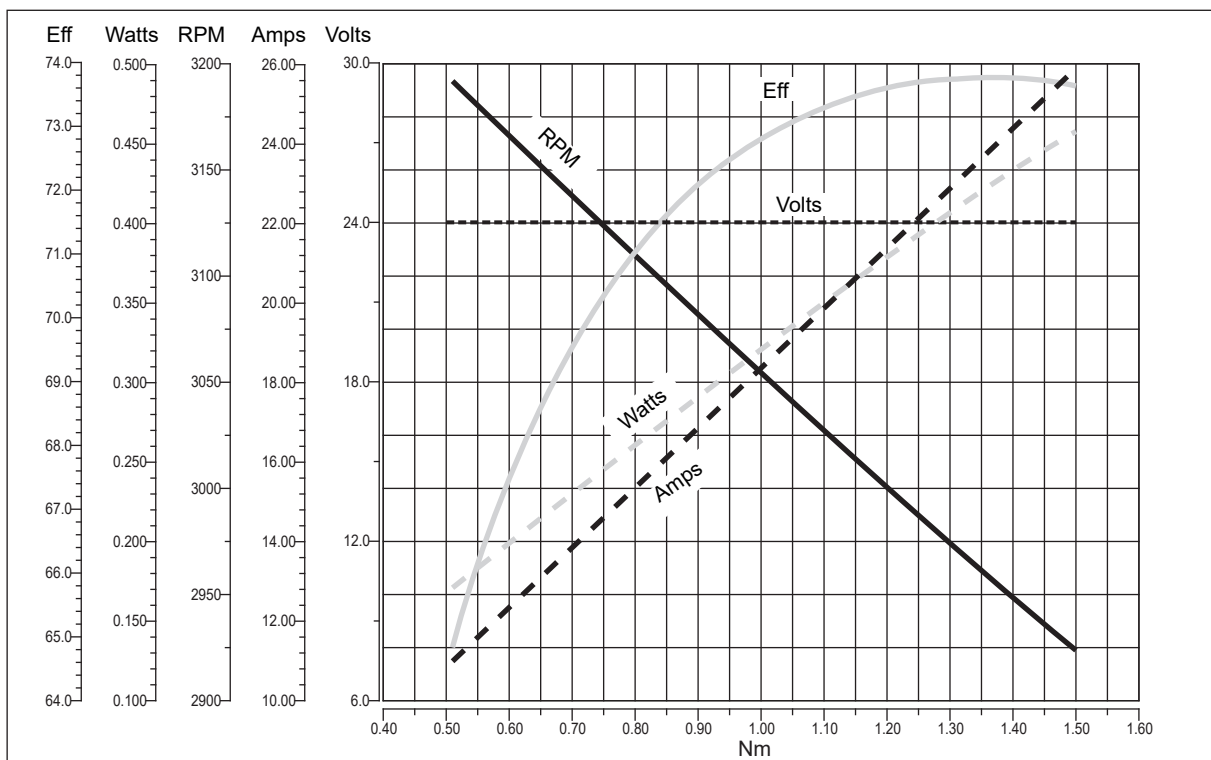

EC IP66



**EC350.120.66 - EC350.240.66**

**Caratteristiche**

**Features**

Costruzione	Tubolare, senza ventilazione
Grandezza	Ø 110 mm
Potenza	500 W S2 (350 W S1)
Magneti	4
Supporti	Cuscinetti a sfera
Fori di montaggio	8
Alimentazione	Bassa tensione, 12 o 24 Vcc
Terminali	2 con dadi di fissaggio

Construction	Tubular, without fan
Size	Ø 110 mm
Power	500 W S2 (350 W S1)
Magnets	4
Bearings	Ball bearings
Mounting holes	8
Power supply	Low voltage, 12 or 24 Vdc
Leads terminals	2, with double nut

Tipo Type	S	Pn [W]	V [V]	I [A]	IC	FF	Mn [Nm]	n <sub>1</sub> [min <sup>-1</sup> ]	IP	Kg
EC350.120.66	S1	350	12	42	F	1	1.12	3000	66	5.1
	S2 30'	500		58.8			1.57			
EC350.240.66	S1	350	24	21			1.12			5.3
	S2 30'	500		29.4			1.57			

**Dimensioni**

**Dimensions**

**EC350.120.66**  
**EC350.240.66**

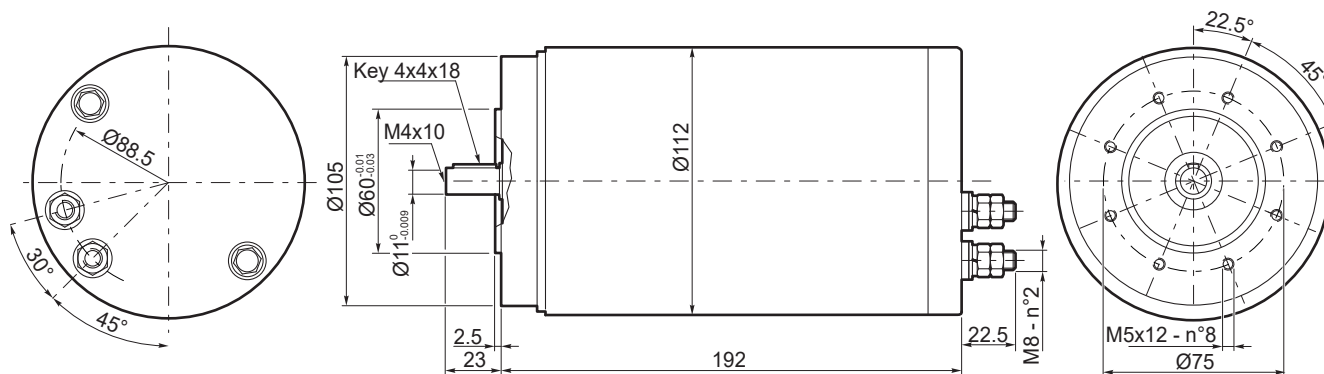

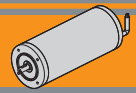

**EC350.120.66**

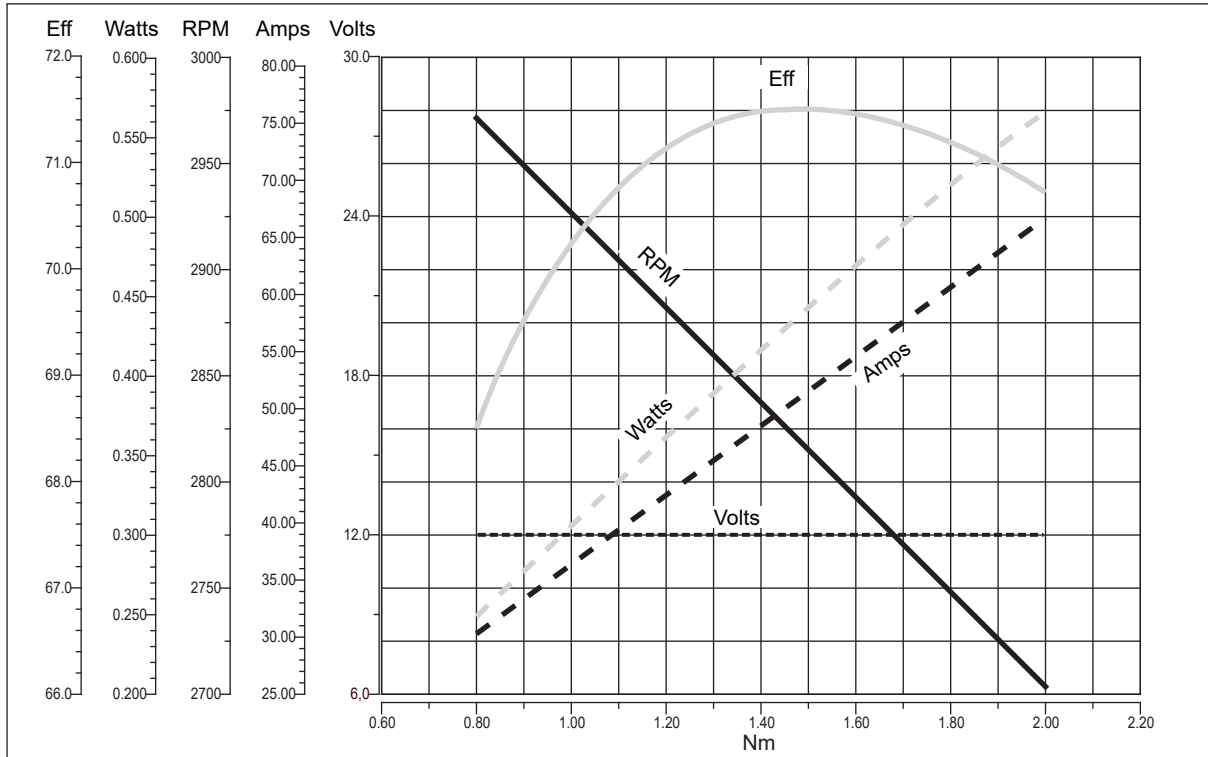

**EC350.240.66**

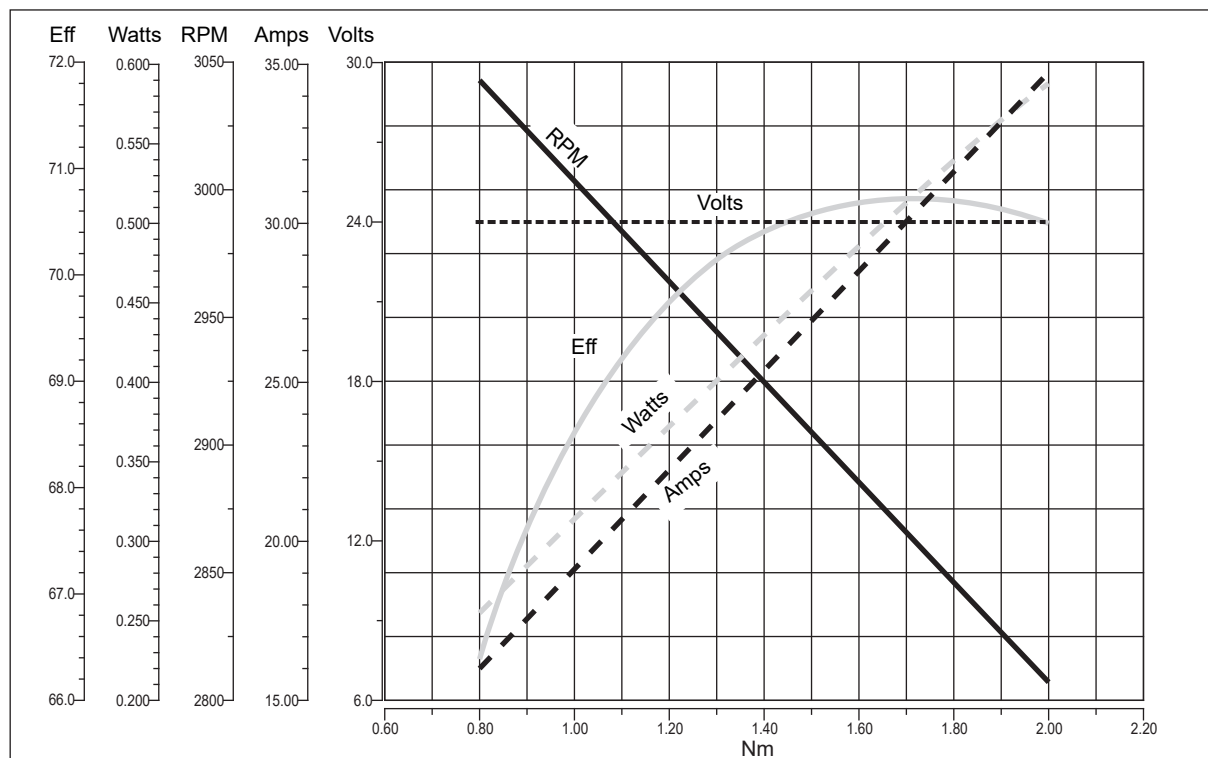

EC IP66

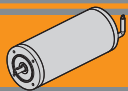

### EC600.120.66 - EC600.240.66

#### Caratteristiche

#### Features

Costruzione	Tubolare, senza ventilazione
Grandezza	Ø 110 mm
Potenza	800 W S2 (600 W S1)
Magneti	4
Supporti	Cuscinetti a sfera
Fori di montaggio	8
Alimentazione	Bassa tensione, 12 o 24 Vcc
Terminali	2 con doppio dado di fissaggio

Construction	Tubular, without fan
Size	Ø 110 mm
Power	800 W S2 (600 W S1)
Magnets	4
Bearings	Ball bearings
Mounting holes	8
Power supply	Low voltage, 12 or 24 Vdc
Leads terminals	2, with double nut

Tipo Type	S	Pn [W]	V [V]	I [A]	IC	FF	Mn [Nm]	n <sub>1</sub> [min <sup>-1</sup> ]	IP	Kg
EC600.120.66	S1	600	12	71	F	1	1.91	3000	66	6.6
	S2 30'	800		94.4			2.54			
EC600.240.66	S1	600	24	35.5			1.91			7.1
	S2 30'	800		47.2			2.54			

#### Dimensioni

#### Dimensions

#### EC600.120.66

#### EC600.240.66

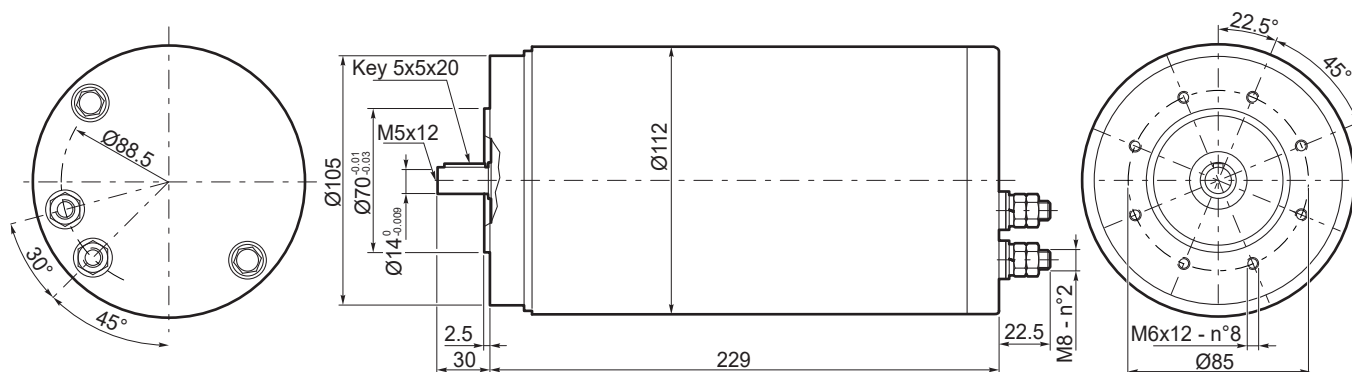



**EC600.120.66**

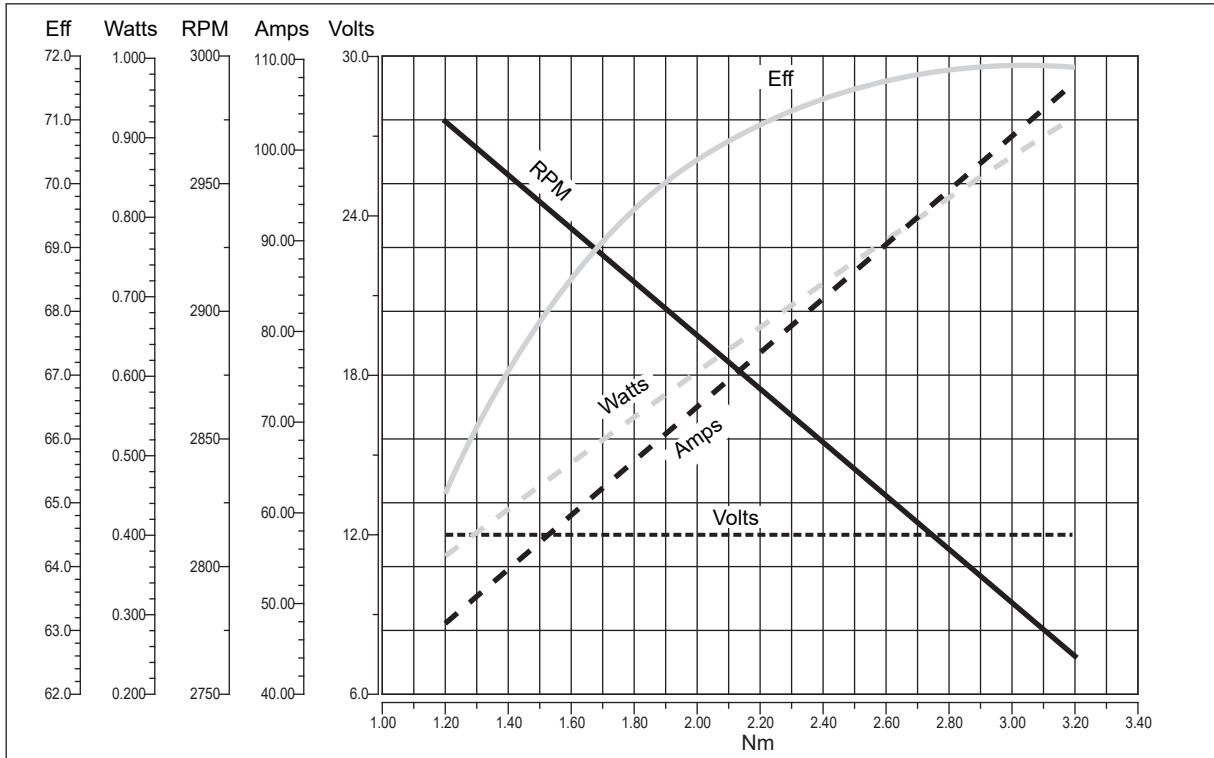

**EC600.240.66**

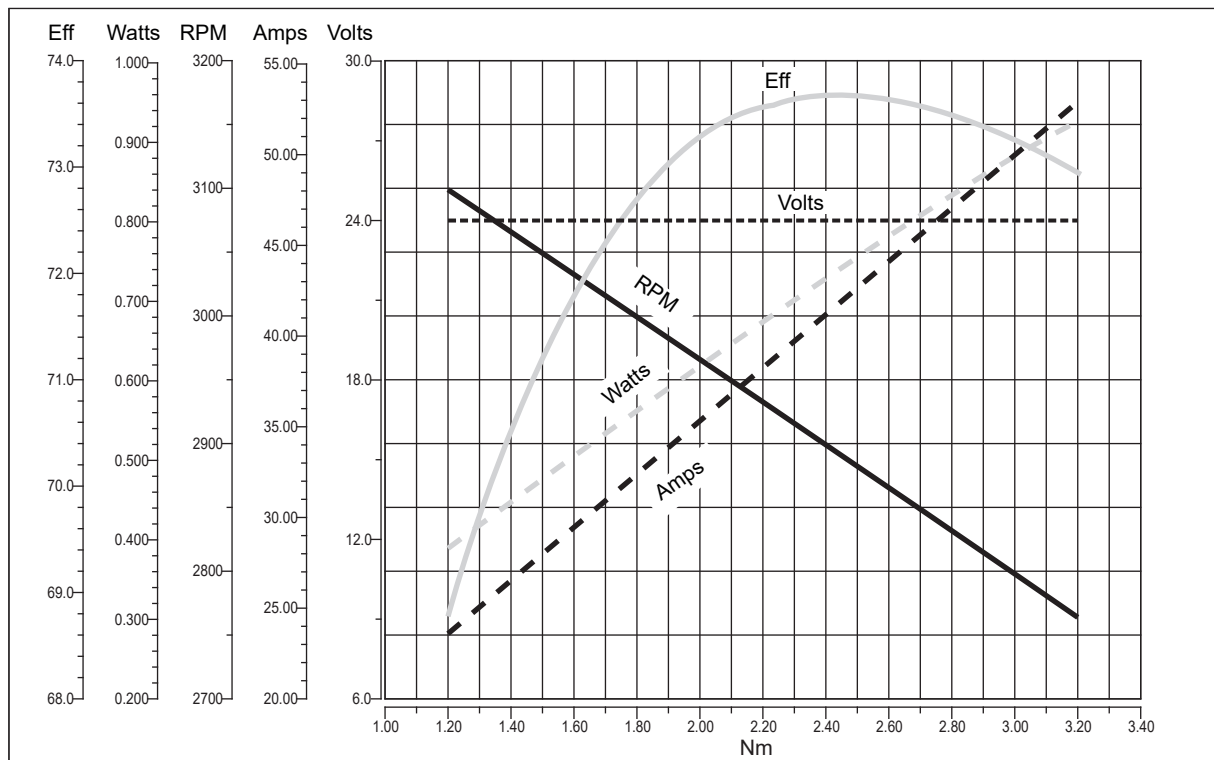

EC IP66





Ferrite

Motoriduttori CC ad ingranaggi cilindrici  
**DC helical in-line gearmotors**





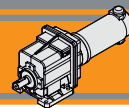

<b>Indice</b>	<b>Index</b>	Pag. Page
Caratteristiche tecniche	<i>Technical features</i>	<b>M2</b>
Designazione	<i>Classification</i>	<b>M2</b>
Sensi di rotazione	<i>Direction of rotation</i>	<b>M3</b>
Lubrificazione	<i>Lubrication</i>	<b>M3</b>
Simbologia	<i>Symbols</i>	<b>M3</b>
Carichi radiali	<i>Radial loads</i>	<b>M4</b>
Motori applicabili	<i>IEC Motor adapters</i>	<b>M4</b>
Dati tecnici per servizio S2	<i>Technical data for S2 duty</i>	<b>M5</b>
Dimensioni	<i>Dimensions</i>	<b>M9</b>

Questa sezione annulla e sostituisce ogni precedente edizione o revisione. Qualora questa sezione non Vi sia giunta in distribuzione controllata, l'aggiornamento dei dati ivi contenuto non è assicurato. **In tal caso la versione più aggiornata è disponibile sul nostro sito internet [www.transtecno.com](http://www.transtecno.com)**

*This section replaces any previous edition and revision. If you obtained this catalogue other than through controlled distribution channels, the most up to date content is not guaranteed. In this case the latest version is available on our web site [www.transtecno.com](http://www.transtecno.com)*

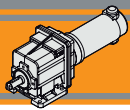

### Caratteristiche tecniche

Le caratteristiche principali dei motoriduttori CC ad ingranaggi cilindrici a magneti permanenti in ferrite serie ECMG sono:

- Alimentazione in bassa tensione 12/24 Vcc
- Possibilità di montaggio encoder
- Potenze motore disponibili da 100 a 800W S2
- Magneti in ferrite
- Carcasse dei riduttori in pressofusione di alluminio
- Lubrificazione permanente con olio sintetico
- Ingranaggi sempre rettificati
- Disponibili con giunto elastico in entrata

### Technical features

The main features of ECMG ferrite permanent magnets DC helical in-line gearmotors range are:

- Low voltage power supply 12/24 Vdc
- Suitable for encoder assembly
- Motor power ratings available from 100 to 800W S2
- Ferrite magnets
- Die-cast aluminum housing
- Permanent synthetic oil long-life lubrication
- Ground helical gears
- Input flexible coupling available

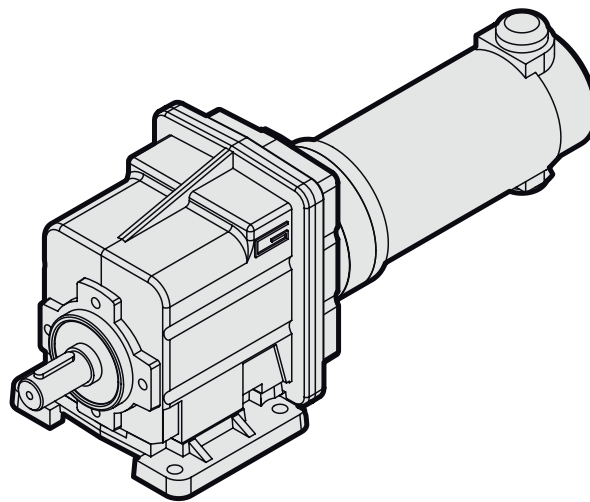

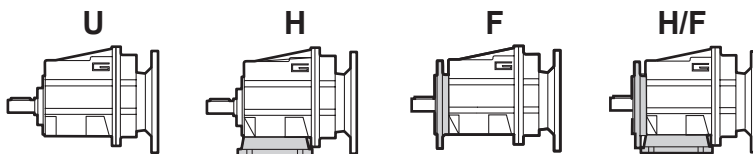

### Designazione

### Classification

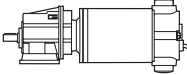

MOTORIDUTTORE / GEARMOTOR

ECMG	100/002						U	8.99	D20	240	FX
Tipo Type	Grandezza Size						Versione Version	Rapporto Ratio	Albero uscita Output shaft	Versione motore Motor version	Giunto elastico Flexible coupling
<b>ECMG</b>  	070/002	100/002	180/002	250/002	350/002	600/002	<b>U...</b> <b>H...</b> <b>F...</b> <b>H.../F...</b>	vedi tabelle <i>see tables</i>	vedi tabelle <i>see tables</i>	<b>120</b> <b>240</b> <b>24E</b>	<b>FX</b>  
	070/012	100/012	180/012	250/012	350/012	600/012					
	070/013	100/013	180/013	250/013	350/013	600/013					
	070/022	100/022	180/022	250/022	350/022	600/022					
	070/023	100/023	180/023	250/023	350/023	600/023					
	070/033	100/033	180/033	250/033	350/033	600/032					
	070/043	100/043	180/043	250/043	350/043	600/033					
						600/042					
						600/043					

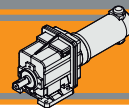

Sensi di rotazione

Direction of rotation

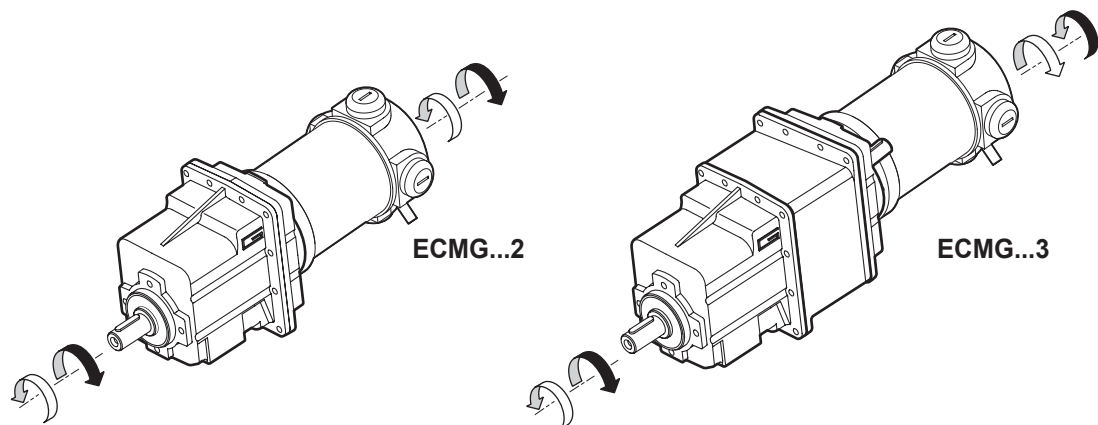

Lubrificazione

Lubrication

Tutti i riduttori sono forniti completi di lubrificante sintetico viscosità 320, pertanto possono essere installati in qualunque posizione di montaggio e non necessitano di manutenzione.

*Permanent synthetic oil long-life lubrication ( viscosity grade 320) makes it possible to use in all mounting positions; for this reason they can be installed in any assembly position and do not require maintenance.*

Simbologia

Symbols

$n_1$	[min <sup>-1</sup> ]	Velocità in ingresso / <i>Input speed</i>
$n_2$	[min <sup>-1</sup> ]	Velocità in uscita / <i>Output speed</i>
$i$		Rapporto di riduzione / <i>Ratio</i>
$P_1$	[kW]	Potenza in entrata / <i>Input power</i>
$M_2$	[Nm]	Coppia nominale in uscita in funzione di $P_1$ / <i>Output torque referred to <math>P_1</math></i>
$sf$		Fattore di servizio / <i>Service factor</i>
$R_2$	[N]	Carico radiale ammissibile in uscita / <i>Permitted output radial load</i>
$A_2$	[N]	Carico assiale ammissibile in uscita / <i>Permitted output axial load</i>

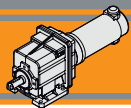

### Carichi radiali

### Radial loads

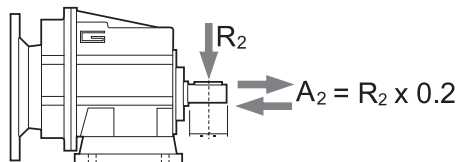

$n_2$ [min <sup>-1</sup> ]	$R_2$ [N]				
	CMG 00	CMG 01	CMG 02	CMG 03	CMG 04
700	416	764	1529	1987	2379
600	437	805	1609	2092	2504
500	465	855	1710	2223	2661
400	501	921	1842	2395	2866
250	586	1077	2154	2801	3353
180	653	1323	2554	3321	3897
150	748	1406	2714	3529	4244
120	806	1631	3467	3801	4572
100	958	1842	3684	4507	5234
80	1032	1984	3969	5042	5991
60	1136	2184	4368	5549	6594
40	1300	2500	5000	6500	8000
10	1300	2500	5000	6500	8000

Quando il carico radiale risultante non è applicato sulla mezza-  
ria dell'albero occorre calcolare quello effettivo con la seguente  
formula:

When the resulting radial load is not applied on the centre  
line of the shaft it is necessary to calculate the effective load with the  
following formula:

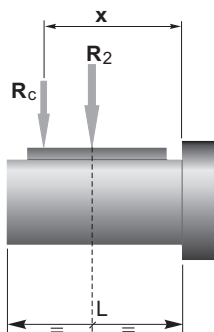

	CMG 00	CMG 01	CMG 02	CMG 03	CMG 04
<b>a</b>	73	104	117	132	150
<b>b</b>	53	84	92	102	115
<b>R<sub>2MAX</sub></b>	1300	2500	5000	6500	8000

$$R_c = \frac{R_2 \cdot a}{(b+x)} \leq R_{2MAX}$$

$$R \leq R_c$$

a, b = valori riportati nella tabella  
a, b = values given in the table

### Motori applicabili

### IEC Motor adapters

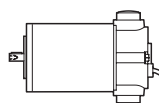

		EC						
		070.12E 070.24E	100.120 100.240 100.24E	180.120 180.240	180.24E	250.120 250.240	350.120 350.240	600.120 600.240
<b>CMG</b>	<b>002</b>	5.03 - 55.10	5.03 - 55.10 *	5.03 - 55.10				
	<b>012</b>	3.82 - 60.15	3.82 - 60.15 *	3.82 - 60.15				
	<b>013</b>	63.22 - 443.59	63.22 - 443.59 *	63.22 - 443.59				
	<b>022</b>	3.66 - 60.90	3.66 - 60.90 *	3.66 - 60.90				
	<b>023</b>	64.01 - 449.14	64.01 - 449.14 *	64.01 - 449.14				
	<b>032</b>						**	3.74 - 60.80 (!)
	<b>033</b>	72.83 - 427.03	72.83 - 427.03 *	72.83 - 427.03				
	<b>042</b>						**	3.74 - 60.80 (!)
	<b>043</b>	72.83 - 427.03	72.83 - 427.03 *	72.83 - 427.03				

5.03 - 55.10

Rapporti di riduzione i  
Ratio i

(!): Solo IEC 71B5 con giunto FX  
71 B5 only with FX coupling

\*: Motore inclinato con portaspazzole a 45°  
Motor assembly with brush holder inclined 45°

\*\* : Contattare il servizio tecnico  
Please contact our technical service

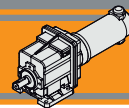

Dati tecnici per servizio S2

Technical data for S2 duty

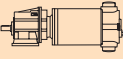
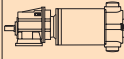
P <sub>1</sub> [W]	n <sub>2</sub> [min <sup>-1</sup> ]	M <sub>2</sub> [Nm]	sf	i		Versione motore Motor version	P <sub>1</sub> [W]	n <sub>2</sub> [min <sup>-1</sup> ]	M <sub>2</sub> [Nm]	sf	i		Versione motore Motor version	
<b>100</b>							<b>140</b>							
(3000 min <sup>-1</sup> )	<b>596</b>	1.5	20.2	5.03	<b>070/002</b>	12E/24E	(3000 min <sup>-1</sup> )	<b>596</b>	2.2	14.4	5.03	<b>100/002</b>	120/240/24E *	
	<b>492</b>	1.9	16.6	6.10		120.66/240.66			<b>492</b>	2.6	11.9		6.10	120.66/240.66
	<b>401</b>	2.3	13.5	7.49					<b>401</b>	3.2	9.7		7.49	
	<b>334</b>	2.7	14.2	8.99					<b>334</b>	3.8	10.1		8.99	
	<b>295</b>	3.1	12.6	10.16					<b>295</b>	4.3	9.0		10.16	
	<b>249</b>	3.7	10.6	12.07					<b>249</b>	5.2	7.6		12.07	
	<b>224</b>	4.1	13.4	13.40					<b>224</b>	5.7	9.6		13.40	
	<b>198</b>	4.6	11.9	15.14					<b>198</b>	6.5	8.5		15.14	
	<b>165</b>	5.5	9.9	18.17					<b>165</b>	7.8	7.1		18.17	
	<b>139</b>	6.6	8.3	21.58					<b>139</b>	9.2	6.0		21.58	
	<b>128</b>	7.2	7.7	23.51					<b>128</b>	10	5.5		23.51	
	<b>120</b>	7.7	7.2	25.10					<b>120</b>	11	5.1		25.10	
	<b>111</b>	8.3	6.6	27.08					<b>111</b>	12	4.7		27.08	
	<b>92</b>	9.9	5.5	32.49					<b>92</b>	14	4.0		32.49	
	<b>71</b>	13	4.3	42.04					<b>71</b>	18	3.1		42.04	
	<b>67</b>	14	4.0	44.89					<b>67</b>	19	2.9		44.89	
	<b>61</b>	15	3.7	48.86					<b>61</b>	21	2.6		48.86	
	<b>54</b>	17	3.3	55.10					<b>54</b>	24	2.3		55.10	
	<b>61</b>	15	6.3	49.00	<b>070/012</b>	12E/24E		<b>85</b>	15	6.2	35.47	<b>100/012</b>	120/240/24E*	
	<b>56</b>	16	5.8	53.33		120.66/240.66			<b>65</b>	20	4.8		45.89	120.66/240.66
	<b>50</b>	18	5.1	60.15					<b>61</b>	21	4.5		49.00	
	<b>47</b>	19	5.0	63.22	<b>070/013</b>	12E/24E		<b>56</b>	23	4.1	53.33			
	<b>40</b>	22	4.2	75.08		120.66/240.66			<b>50</b>	26	3.7	60.15		
	<b>34</b>	27	3.5	89.17					<b>47</b>	26	3.5	63.22	<b>100/013</b>	120/240/24E*
	<b>27</b>	34	2.8	113.05					<b>40</b>	31	3.0	75.08		120.66/240.66
	<b>22</b>	40	2.3	134.27					<b>34</b>	37	2.5	89.17		
	<b>17</b>	52	1.8	173.72					<b>27</b>	47	2.0	113.05		
	<b>15</b>	60	1.6	202.16					<b>22</b>	56	1.7	134.27		
	<b>11</b>	78	1.2	261.57					<b>17</b>	73	1.3	173.72		
	<b>10</b>	91	1.0	304.00					<b>15</b>	85	1.1	202.16		
	<b>7.6</b>	118	0.8	393.33					<b>11</b>	110	0.9	261.57		
	<b>6.8</b>	133	0.7	443.59				<b>10</b>	127	0.7	304.00			
	<b>22</b>	41	3.8	135.95	<b>070/023</b>	12E/24E		<b>7.6</b>	134	0.7	393.33			
	<b>17</b>	53	3.0	175.89		120.66/240.66			<b>6.8</b>	134	0.7	443.59		
	<b>15</b>	61	2.5	204.69				<b>33</b>	38	4.1	90.29	<b>100/023</b>	120/240/24E*	
	<b>11</b>	79	2.0	264.84				<b>26</b>	48	3.3	114.46		120.66/240.66	
	<b>10</b>	92	1.7	307.80				<b>22</b>	57	2.7	135.95			
	<b>7.5</b>	119	1.3	398.25				<b>17</b>	74	2.1	175.89			
	<b>6.7</b>	134	1.2	449.14				<b>15</b>	86	1.8	204.69			
	<b>13</b>	67	3.5	225.47	<b>070/033</b>	12E/24E		<b>11</b>	111	1.4	264.84			
	<b>11</b>	78	3.0	262.05		120.66/240.66			<b>10</b>	129	1.2		307.80	
	<b>9.2</b>	97	2.4	325.79					<b>7.5</b>	167	0.9		398.25	
	<b>7.9</b>	113	2.1	378.64					<b>6.7</b>	188	0.8		449.14	
	<b>7.0</b>	128	1.8	427.03					<b>17</b>	73	3.2		174.26	<b>100/033</b>
	<b>9.2</b>	97	4.0	325.79		<b>070/043</b>	12E/24E		<b>13</b>	94	2.5	225.47	120.66/240.66	
	<b>7.9</b>	113	3.4	378.64	120.66/240.66				<b>11</b>	110	2.1	262.05		
	<b>7.0</b>	128	3.1	427.03					<b>9.2</b>	136	1.7	325.79		
									<b>7.9</b>	159	1.5	378.64		
									<b>7.0</b>	179	1.3	427.03		
									<b>11</b>	110	3.6	262.05	<b>100/043</b>	120/240/24E*
								<b>9.2</b>	136	2.9	325.79	120.66/240.66		
								<b>7.9</b>	159	2.5	378.64			
								<b>7.0</b>	179	2.2	427.03			

NOTA  
Verificare sempre che la coppia M2 utilizzata non ecceda il valore indicato nelle caselle in grigio  
NOTE  
Please check that the output torque M2 does not exceed the value in the grey areas

NOTA: per servizio continuo o altamente intermittente, contattare il servizio tecnico

NOTE: for continuous or highly intermittent duty, please contact our technical service

\*: Motore inclinato con portaspazzole a 45°  
Motor assembly with brush holder inclined 45°



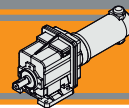

Dati tecnici per servizio S2

Technical data for S2 duty

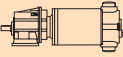
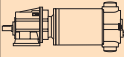
P <sub>1</sub> [W]	n <sub>2</sub> [min <sup>-1</sup> ]	M <sub>2</sub> [Nm]	sf	i		Versione motore Motor version	P <sub>1</sub> [W]	n <sub>2</sub> [min <sup>-1</sup> ]	M <sub>2</sub> [Nm]	sf	i		Versione motore Motor version	
<b>350</b>							<b>500</b>							
(3000 min <sup>-1</sup> )	<b>84</b>	38	4.1	35.91	<b>250/022</b>	120/240	(3000 min <sup>-1</sup> )	<b>785</b>	5.8	8.1	3.82	<b>350/012</b>	120/240	
	<b>65</b>	50	3.1	46.46		120.66/240.66		<b>648</b>	7.1	6.6	4.63		120.66/240.66	
	<b>60</b>	53	2.9	49.61				<b>527</b>	8.7	5.4	5.69			
	<b>56</b>	58	2.7	54.00				<b>389</b>	12	5.3	7.72			
	<b>49</b>	65	2.4	60.90				<b>327</b>	14	4.4	9.17			
	<b>47</b>	67	2.3	64.01	<b>250/023</b>	120/240		<b>306</b>	15	4.1	9.81			
	<b>39</b>	80	2.0	76.02		120.66/240.66		<b>261</b>	18	4.4	11.5			
	<b>33</b>	95	1.6	90.29				<b>252</b>	18	4.3	11.9			
	<b>26</b>	120	1.3	114.46				<b>217</b>	21	4.5	13.80			
	<b>22</b>	142	1.1	135.95				<b>205</b>	22	4.2	14.62			
	<b>17</b>	184	0.8	175.89			<b>168</b>	27	3.4	17.86				
	<b>15</b>	214	0.7	204.69			<b>157</b>	29	3.2	19.07				
	<b>11</b>	223	0.7	264.84			<b>151</b>	30	3.1	19.83				
	<b>41</b>	76	3.1	72.83	<b>250/033</b>	120/240		<b>127</b>	36	2.6	23.56			
	<b>31</b>	102	2.3	97.45		120.66/240.66		<b>101</b>	45	2.1	29.56			
	<b>26</b>	121	1.9	115.74				<b>85</b>	54	1.7	35.47			
	<b>21</b>	147	1.6	140.81				<b>65</b>	70	1.3	45.89			
	<b>17</b>	183	1.3	174.26				<b>61</b>	75	1.3	49.00			
	<b>13</b>	236	1.0	225.47			<b>56</b>	81	1.2	53.33				
	<b>11</b>	274	0.9	262.05			<b>50</b>	92	1.0	60.15				
	<b>9.2</b>	341	0.7	325.79			<b>47</b>	95	1.0	63.22	<b>350/013</b>	120/240		
	<b>7.9</b>	334	0.7	378.64			<b>40</b>	112	0.8	75.08		120.66/240.66		
	<b>7.0</b>	334	0.7	427.03			<b>34</b>	133	0.7	89.17				
	<b>41</b>	76	5.1	72.83	<b>250/043</b>	120/240		<b>27</b>	134	0.7		113.05		
	<b>31</b>	102	3.8	97.45		120.66/240.66		<b>22</b>	134	0.7		134.27		
	<b>26</b>	121	3.2	115.74				<b>126</b>	36	4.3	23.85	<b>350/022</b>	120/240	
	<b>21</b>	147	2.6	140.81				<b>100</b>	46	3.4	29.93		120.66/240.66	
	<b>17</b>	183	2.1	174.26				<b>84</b>	55	2.8	35.91			
	<b>13</b>	236	1.7	225.47			<b>65</b>	71	2.2	46.46				
	<b>11</b>	274	1.4	262.05			<b>60</b>	76	2.1	49.61				
	<b>9.2</b>	341	1.1	325.79			<b>56</b>	83	1.9	54.00				
	<b>7.9</b>	397	1.0	378.64			<b>49</b>	93	1.7	60.90				
	<b>7.0</b>	447	0.9	427.03			<b>47</b>	96	1.6	64.01	<b>350/023</b>	120/240		
	<b>41</b>	76	5.1	72.83			<b>39</b>	114	1.4	76.02		120.66/240.66		
	<b>31</b>	102	3.8	97.45			<b>33</b>	135	1.2	90.29				
	<b>26</b>	121	3.2	115.74			<b>26</b>	171	0.9	114.46				
	<b>21</b>	147	2.6	140.81			<b>22</b>	203	0.8	135.95				
	<b>17</b>	183	2.1	174.26			<b>17</b>	223	0.7	175.89				
	<b>13</b>	236	1.7	225.47			<b>41</b>	109	2.1	72.83	<b>350/033</b>	120/240		
	<b>11</b>	274	1.4	262.05			<b>31</b>	146	1.6	97.45		120.66/240.66		
	<b>9.2</b>	341	1.1	325.79			<b>26</b>	173	1.4	115.74				
	<b>7.9</b>	397	1.0	378.64			<b>21</b>	211	1.1	140.81				
	<b>7.0</b>	447	0.9	427.03			<b>17</b>	261	0.9	174.26				
	<b>596</b>	7.7	4.0	5.03	<b>350/002</b>	120/240		<b>13</b>	334	0.7	225.47			
	<b>492</b>	9.3	3.3	6.10		120.66/240.66		<b>11</b>	334	0.7	262.05			
	<b>401</b>	11	2.7	7.49										
	<b>334</b>	14	2.8	8.99										
	<b>295</b>	16	2.5	10.16										
	<b>249</b>	18	2.1	12.07										
	<b>224</b>	20	2.7	13.40										
	<b>198</b>	23	2.4	15.14										
	<b>165</b>	28	2.0	18.17										
	<b>139</b>	33	1.7	21.58										
	<b>128</b>	36	1.5	23.51										
	<b>120</b>	38	1.4	25.1										
	<b>111</b>	41	1.3	27.08										
	<b>92</b>	50	1.1	32.49										
	<b>71</b>	64	0.9	42.04										
	<b>67</b>	69	0.8	44.89										
	<b>61</b>	75	0.7	48.86										

NOTA  
Verificare sempre che la coppia M2 utilizzata non ecceda il valore indicato nelle caselle in grigio  
NOTE  
Please check that the output torque M2 does not exceed the value in the grey areas

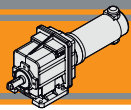

NOTA: per servizio continuo o altamente intermittente, contattare il servizio tecnico  
NOTE: for continuous or highly intermittent duty, please contact our technical service

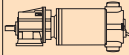

### Dati tecnici per servizio S2

### Technical data for S2 duty

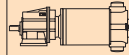
P <sub>1</sub> [W]	n <sub>2</sub> [min <sup>-1</sup> ]	M <sub>2</sub> [Nm]	sf	i		Versione motore Motor version
<b>500</b>						
(3000 min <sup>-1</sup> )	<b>41</b>	109	3.6	72.83	<b>350/043</b>	120/240
	<b>31</b>	146	2.7	97.45		120.66/240.66
	<b>26</b>	173	2.3	115.74		
	<b>21</b>	211	1.9	140.81		
	<b>17</b>	261	1.5	174.26		
	<b>13</b>	337	1.2	225.47		
	<b>11</b>	392	1.0	262.05		
	<b>9.2</b>	487	0.8	325.79		
	<b>7.9</b>	557	0.7	378.64		
	<b>7.0</b>	557	0.7	427.03		

P <sub>1</sub> [W]	n <sub>2</sub> [min <sup>-1</sup> ]	M <sub>2</sub> [Nm]	sf	i		Versione motore Motor version	
<b>800</b>							
(3000 min <sup>-1</sup> )	<b>302</b>	24	3.9	9.93	<b>600/022</b>	120/240	
	<b>272</b>	27	5.8	11.01		120.66/240.66	
	<b>249</b>	29	5.3	12.05			
	<b>227</b>	32	3.9	13.21			
	<b>203</b>	36	4.3	14.81			
	<b>175</b>	42	2.4	17.1			
	<b>149</b>	49	3.2	20.08			
	<b>126</b>	58	2.7	23.85			
	<b>100</b>	73	2.1	29.93			
	<b>84</b>	88	1.8	35.91			
	<b>65</b>	114	1.4	46.46			
	<b>60</b>	121	1.3	49.61			
	<b>56</b>	132	1.2	54.00			
	<b>49</b>	149	1.0	60.90			
	<b>47</b>	153	1.0	64.01	<b>600/023</b>	120/240	
	<b>39</b>	182	0.9	76.02		120.66/240.66	
	<b>33</b>	216	0.7	90.29			
	<b>26</b>	223	0.7	114.46			
	<b>22</b>	223	0.7	135.95			
	<b>120</b>	61	3.8	24.99	<b>600/032</b>	120/240	
	<b>98</b>	75	3.1	30.57		IEC 71B5	
	<b>88</b>	84	2.8	34.20			
	<b>78</b>	94	2.5	38.63		+	
	<b>68</b>	108	2.2	44.18		Giunto FX	
	<b>58</b>	125	1.9	51.30		FX Coupling	
	<b>49</b>	149	1.6	60.80		Solo / Only	
	<b>41</b>	174	1.3	72.83		<b>600/033</b>	120/240
	<b>31</b>	233	1.0	97.45			120.66/240.66
	<b>26</b>	277	0.8	115.74			
	<b>21</b>	334	0.7	140.81			
	<b>17</b>	334	0.7	174.26			
	<b>78</b>	94	4.1	38.63	<b>600/042</b>	120/240	
	<b>68</b>	108	3.6	44.18		IEC 71B5	
	<b>58</b>	125	3.1	51.30			
	<b>49</b>	149	2.5	60.80		+	
						Giunto FX	
					FX Coupling		
					Solo / Only		
	<b>41</b>	174	2.2	72.83	<b>600/043</b>	120/240	
	<b>31</b>	233	1.7	97.45		120.66/240.66	
	<b>26</b>	277	1.4	115.74			
	<b>21</b>	337	1.2	140.81			
	<b>17</b>	417	0.9	174.26			
	<b>13</b>	540	0.7	225.47			
	<b>11</b>	557	0.7	262.05			
	<b>9</b>	557	0.7	325.79			

P <sub>1</sub> [W]	n <sub>2</sub> [min <sup>-1</sup> ]	M <sub>2</sub> [Nm]	sf	i		Versione motore Motor version	
<b>800</b>							
(3000 min <sup>-1</sup> )	<b>596</b>	12	2.5	5.03	<b>600/002</b>	120/240	
	<b>492</b>	15	2.1	6.10		120.66/240.66	
	<b>401</b>	18	1.7	7.49			
	<b>334</b>	22	1.8	8.99			
	<b>295</b>	25	1.6	10.16			
	<b>249</b>	30	1.3	12.07			
	<b>224</b>	33	1.7	13.40			
	<b>198</b>	37	1.5	15.14			
	<b>165</b>	44	1.2	18.17			
	<b>139</b>	53	1.0	21.58			
	<b>128</b>	57	1.0	23.51			
	<b>120</b>	61	0.9	25.10			
	<b>111</b>	66	0.8	27.08			
	<b>92</b>	79	0.7	32.49			
	<b>71</b>	79	0.7	42.04			
	<b>67</b>	79	0.7	44.89			
	<b>785</b>	9	5.0	3.82		<b>600/012</b>	120/240
	<b>648</b>	11	4.2	4.63			120.66/240.66
	<b>527</b>	14	3.4	5.69			
	<b>389</b>	19	3.3	7.72			
	<b>327</b>	22	2.8	9.17			
	<b>306</b>	24	2.6	9.81			
	<b>261</b>	28	2.8	11.5			
	<b>252</b>	29	2.7	11.9			
	<b>217</b>	34	2.8	13.8			
	<b>205</b>	36	2.6	14.62			
	<b>168</b>	44	2.2	17.86			
	<b>157</b>	47	2.0	19.07			
	<b>151</b>	48	1.9	19.83			
	<b>127</b>	58	1.6	23.56			
	<b>101</b>	72	1.3	29.56			
	<b>85</b>	87	1.1	35.47			
	<b>65</b>	112	0.8	45.89			
	<b>61</b>	120	0.8	49.00			
	<b>56</b>	130	0.7	53.33			
	<b>47</b>	134	0.7	63.22	<b>600/013</b>	120/240	
	<b>40</b>	134	0.7	75.08		120.66/240.66	

NOTA  
Verificare sempre che la coppia M<sub>2</sub> utilizzata non ecceda il valore indicato nelle caselle in grigio  
NOTE  
Please check that the output torque M<sub>2</sub> does not exceed the value in the grey areas

NOTA: per servizio continuo o altamente intermittente, contattare il servizio tecnico  
NOTE: for continuous or highly intermittent duty, please contact our technical service

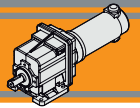

Dimensioni

Dimensions

ECMG..U

ECMG070/002 U

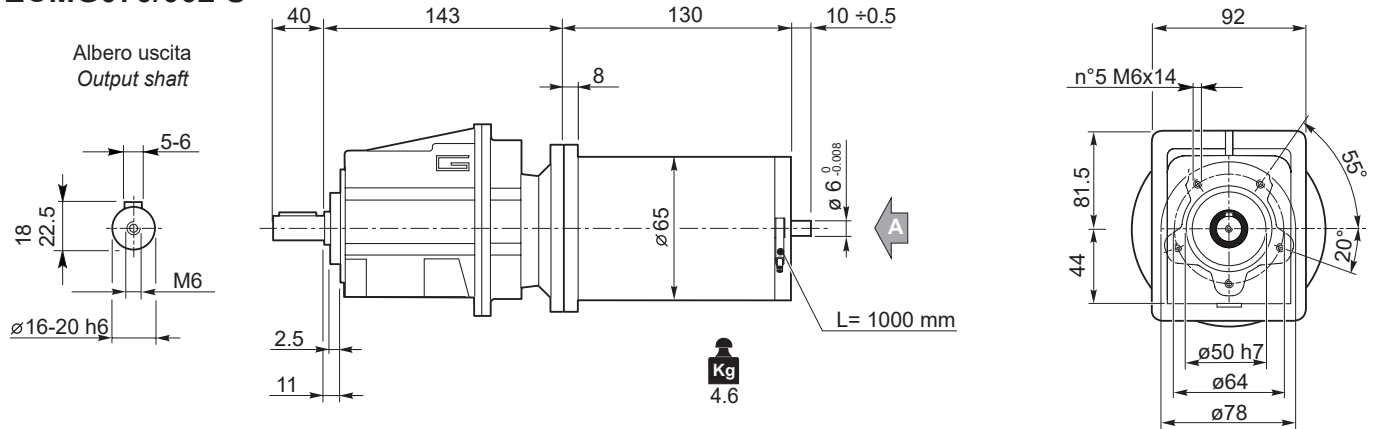

ECMG070/012 U

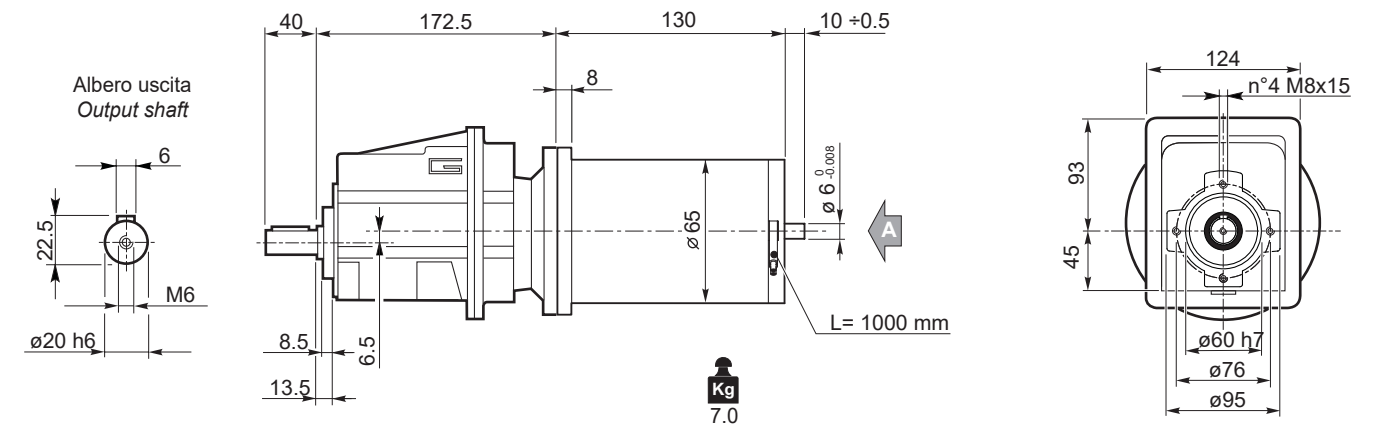

ECMG070/013 U

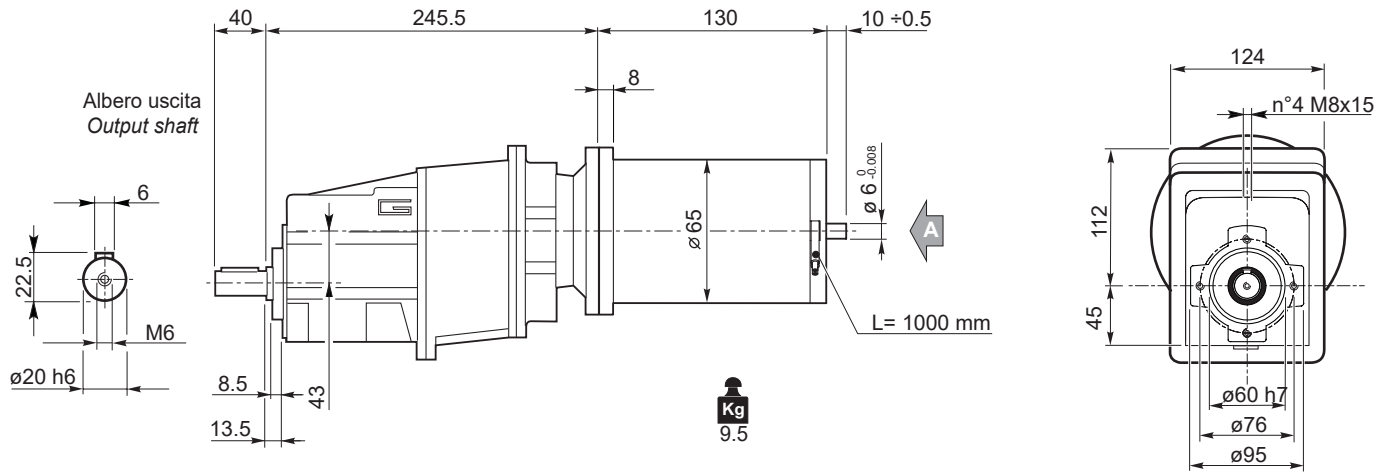

ECMG

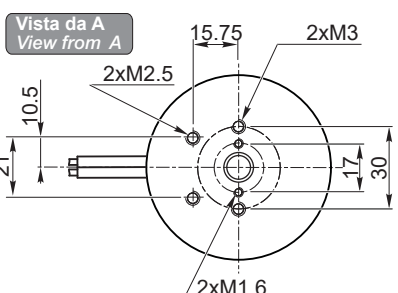

Freno / Brake → I23

Encoder → I24

Motori / Motors IP66 → L2

ECMG...H → M30

ECMG...F → M31

ECMG...H/F → M32

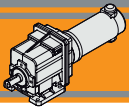

### Dimensioni

### Dimensions

## ECMG..U

### ECMG070/022 U

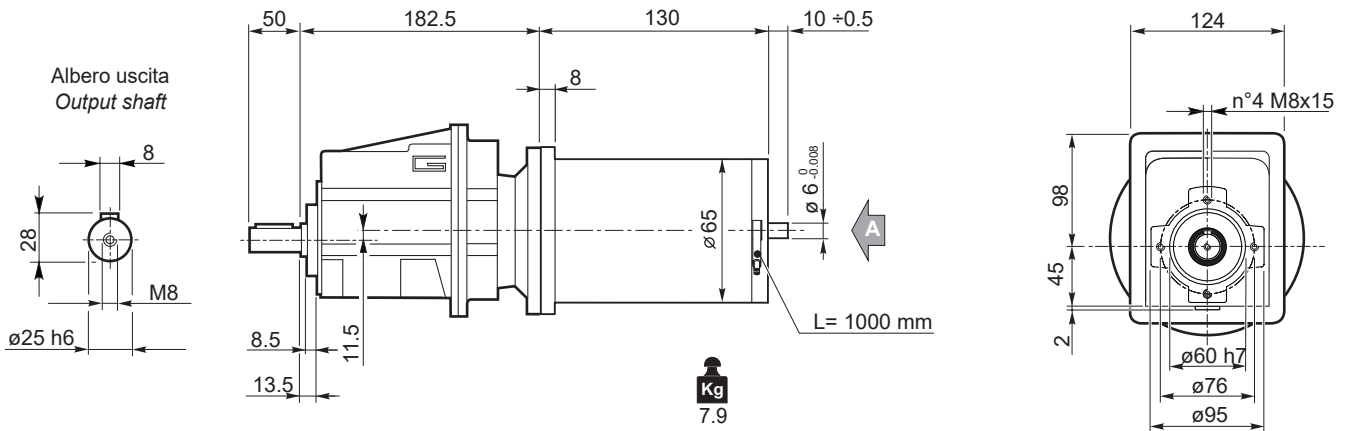

### ECMG070/023 U

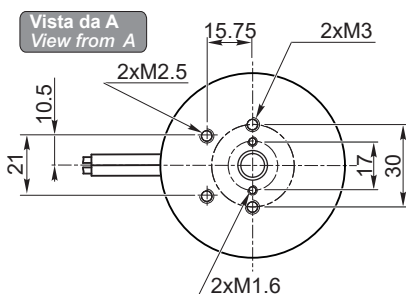
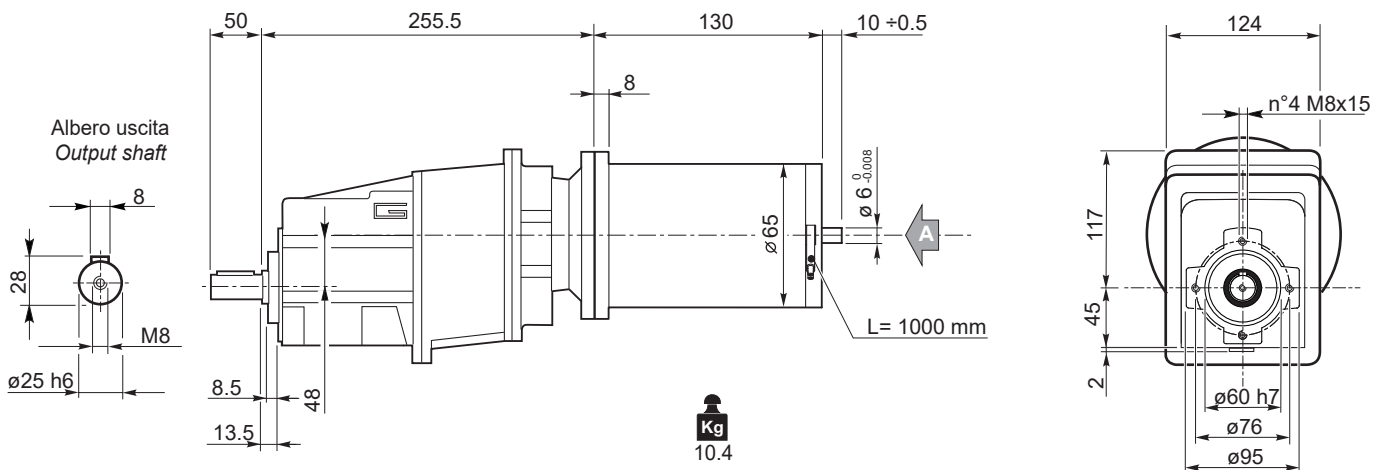

Freno / Brake



I23

ECMG...H



M30

Encoder



I24

ECMG...F



M31

Motori / Motors IP66



L2

ECMG...H/F



M32

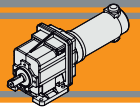

Dimensioni

Dimensions

ECMG..U

ECMG070/033 U

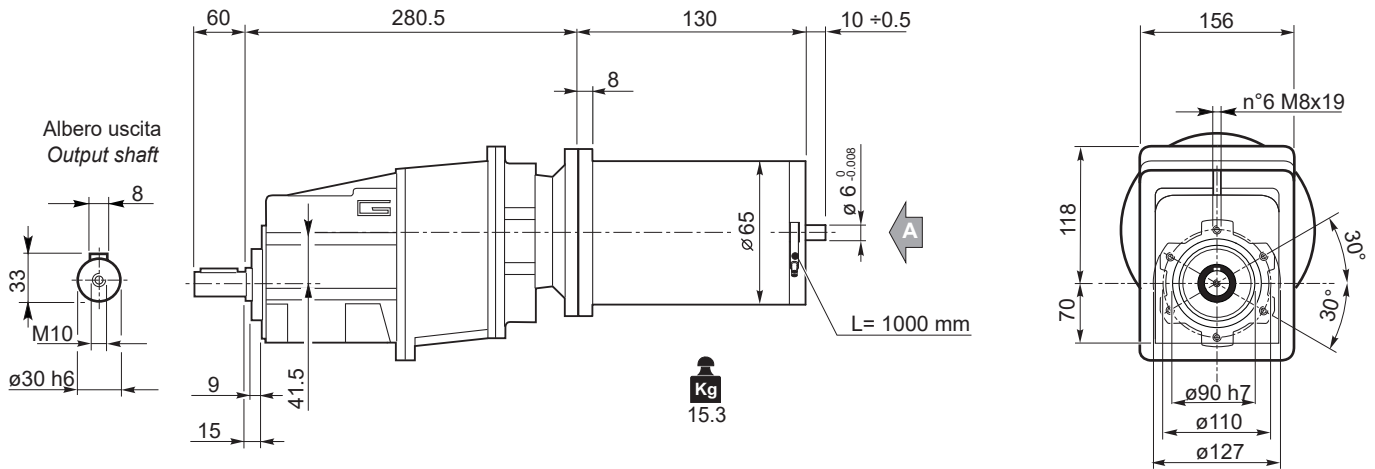

ECMG070/043 U

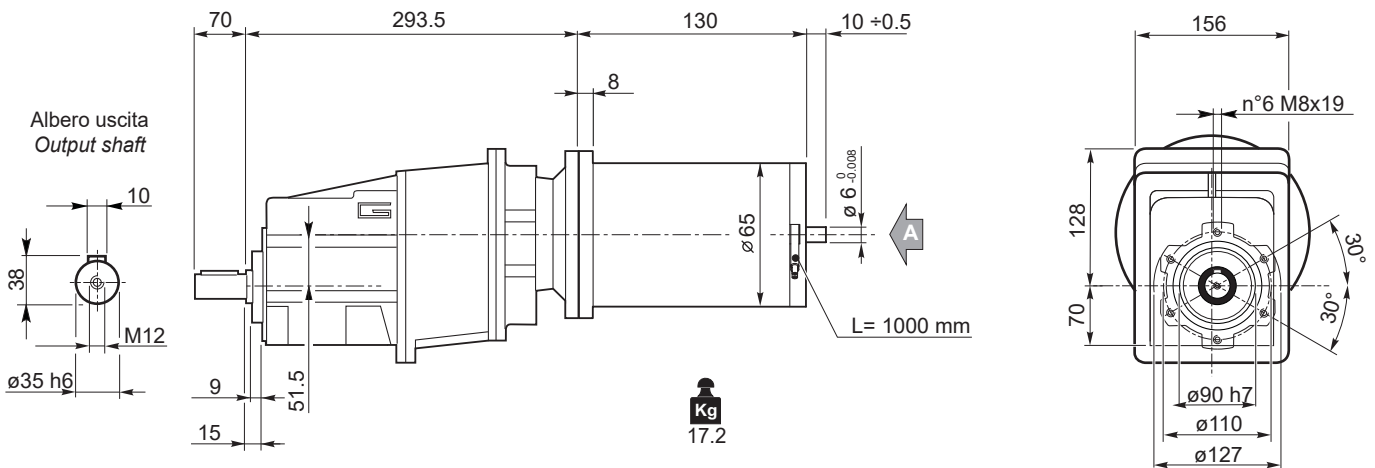

ECMG

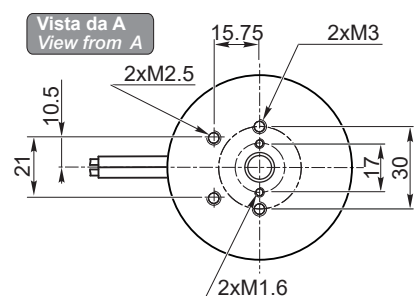

Freno / Brake



I23

Encoder



I24

Motori / Motors IP66



L2

ECMG...H



M30

ECMG...F



M31

ECMG...H/F



M32

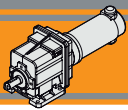

### Dimensioni

### Dimensions

## ECMG..U

### ECMG100/002 U

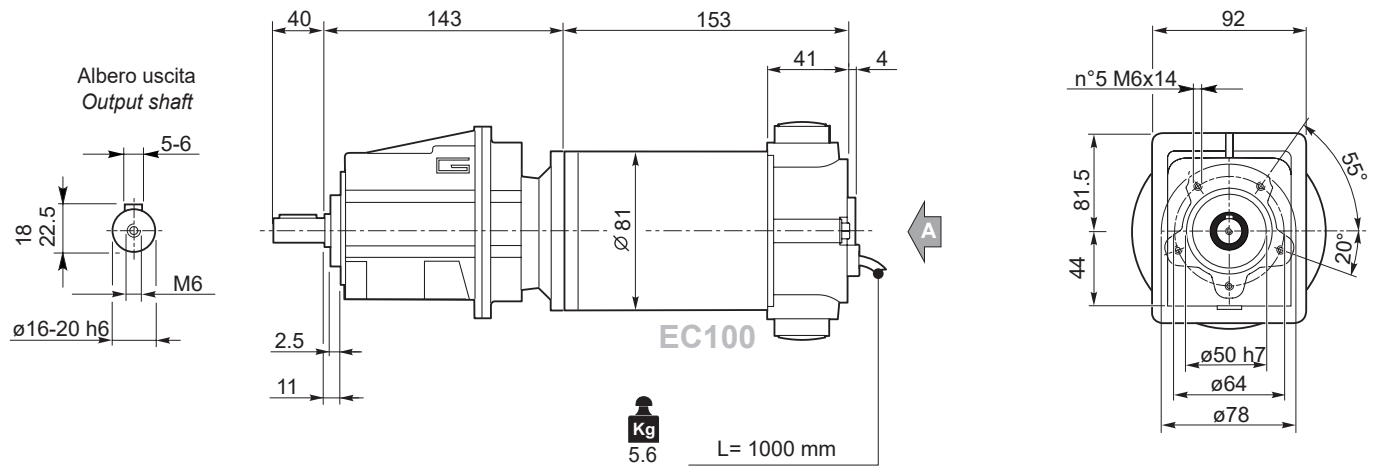

**Nota:** Motore inclinato con portaspazzole a 45°  
**Note:** Motor assembly with brush holder inclined 45°

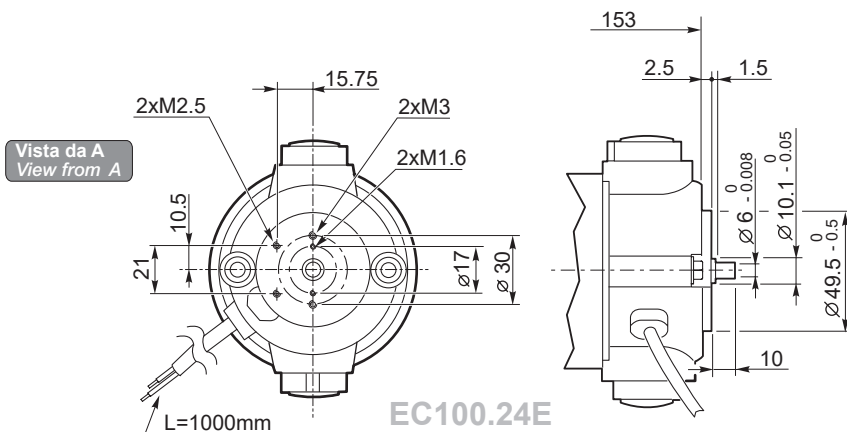

**Nota:** Motore inclinato con portaspazzole a 45°  
**Note:** Motor assembly with brush holder inclined 45°

Freno / Brake

I23

Encoder

I24

Motori / Motors IP66

L4

ECMG...H

M30

ECMG...F

M31

ECMG...H/F

M32

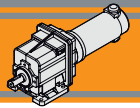

Dimensioni

Dimensions

ECMG..U

ECMG100/012 U

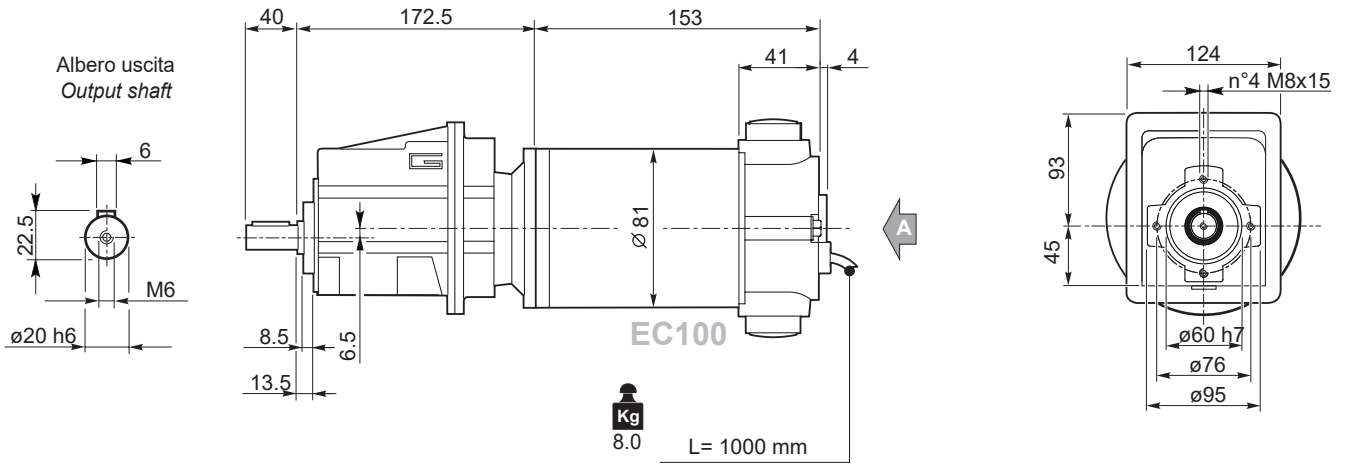

**Nota:** Motore inclinato con portaspazzole a 45°  
**Note:** Motor assembly with brush holder inclined 45°

ECMG100/013 U

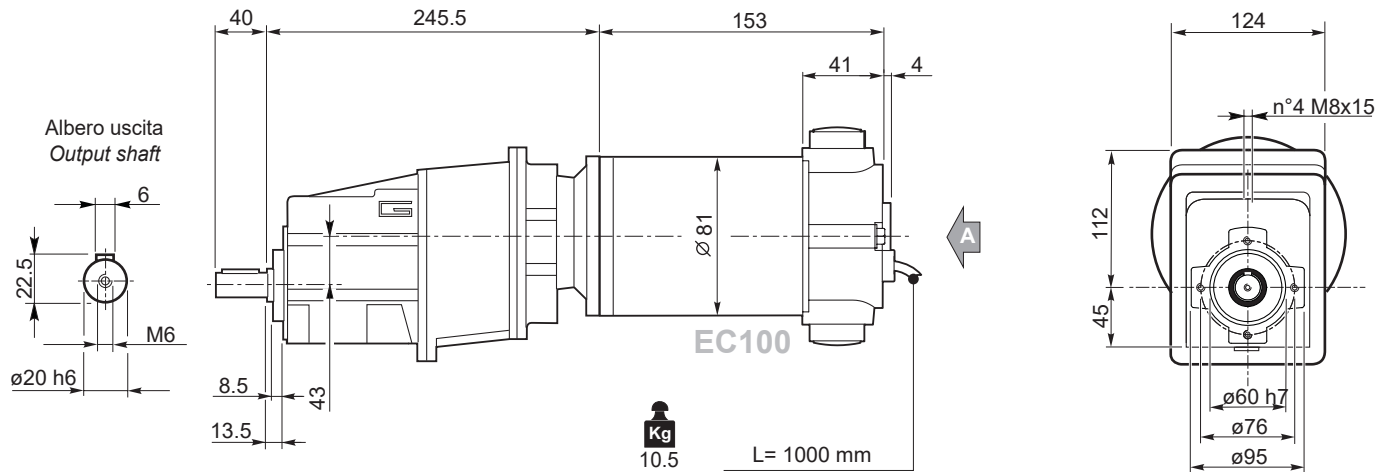

**Nota:** Motore inclinato con portaspazzole a 45°  
**Note:** Motor assembly with brush holder inclined 45°

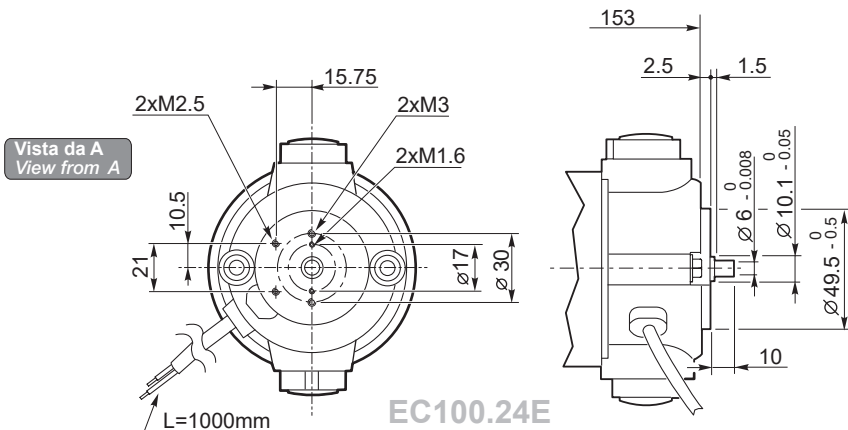

**Nota:** Motore inclinato con portaspazzole a 45°  
**Note:** Motor assembly with brush holder inclined 45°

Freno / Brake → I23

Encoder → I24

Motori / Motors IP66 → L4

ECMG...H → M30

ECMG...F → M31

ECMG...H/F → M32

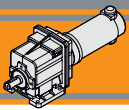

### Dimensioni

## ECMG..U

### ECMG100/022 U

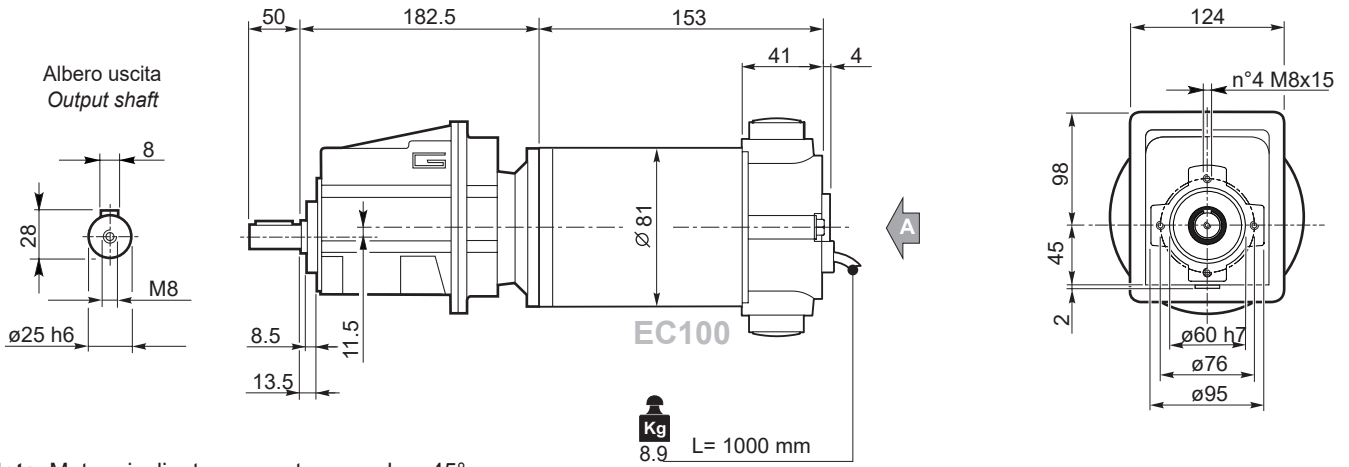

**Nota:** Motore inclinato con portaspazzole a 45°  
**Note:** Motor assembly with brush holder inclined 45°

### ECMG100/023 U

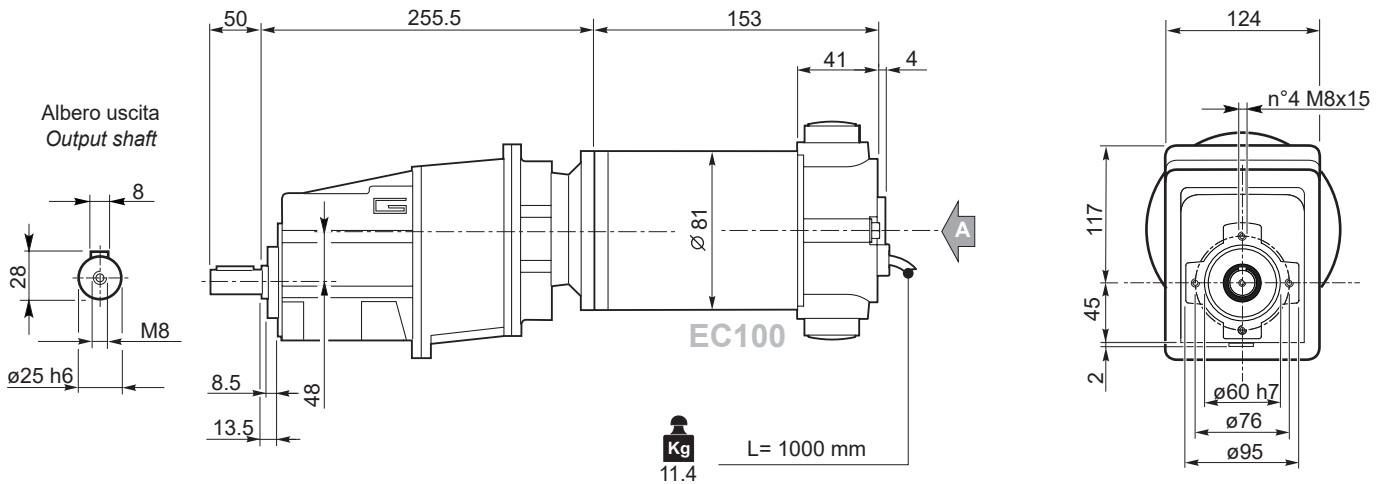

**Nota:** Motore inclinato con portaspazzole a 45°  
**Note:** Motor assembly with brush holder inclined 45°

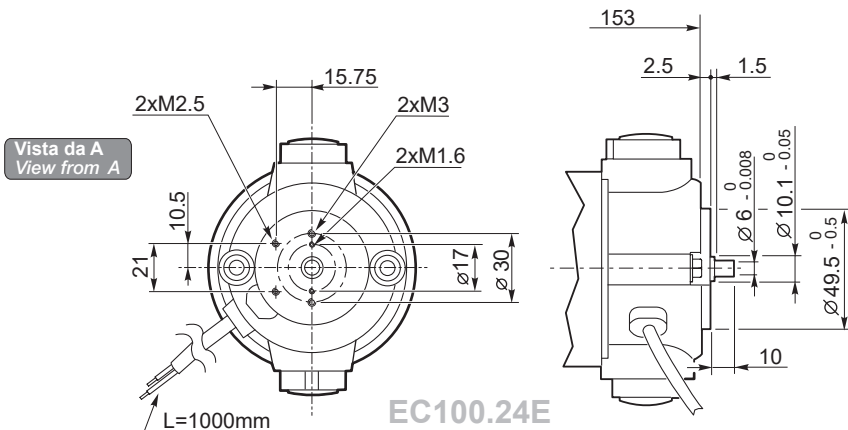

**Nota:** Motore inclinato con portaspazzole a 45°  
**Note:** Motor assembly with brush holder inclined 45°

Freno / Brake → I23

Encoder → I24

Motori / Motors IP66 → L4

ECMG...H → M30

ECMG...F → M31

ECMG...H/F → M32

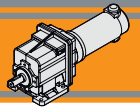

Dimensioni

ECMG..U

ECMG100/033 U

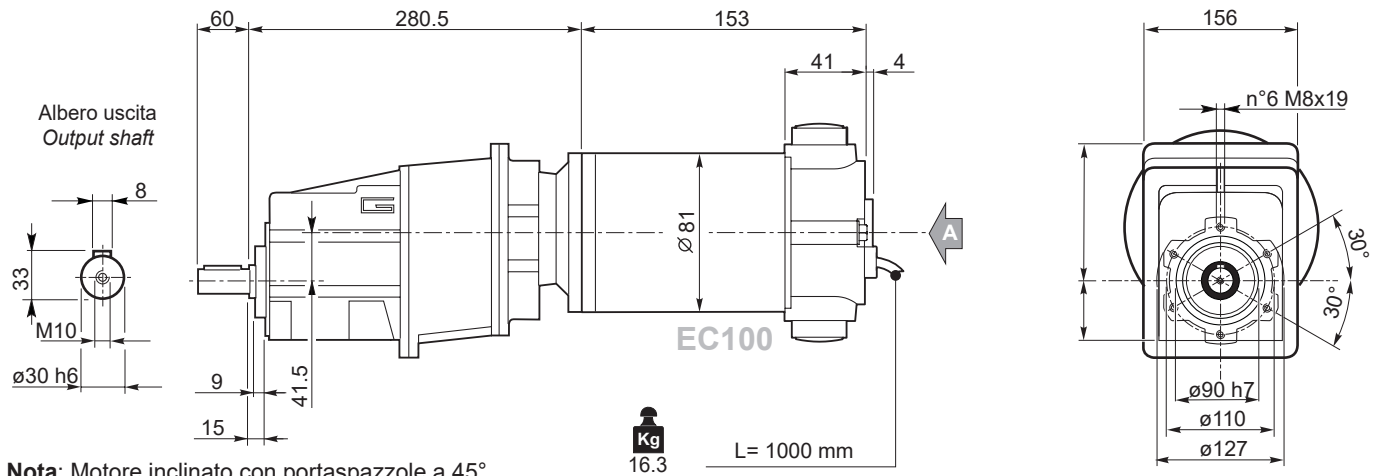

**Nota:** Motore inclinato con portaspazzole a 45°  
**Note:** Motor assembly with brush holder inclined 45°

ECMG100/043 U

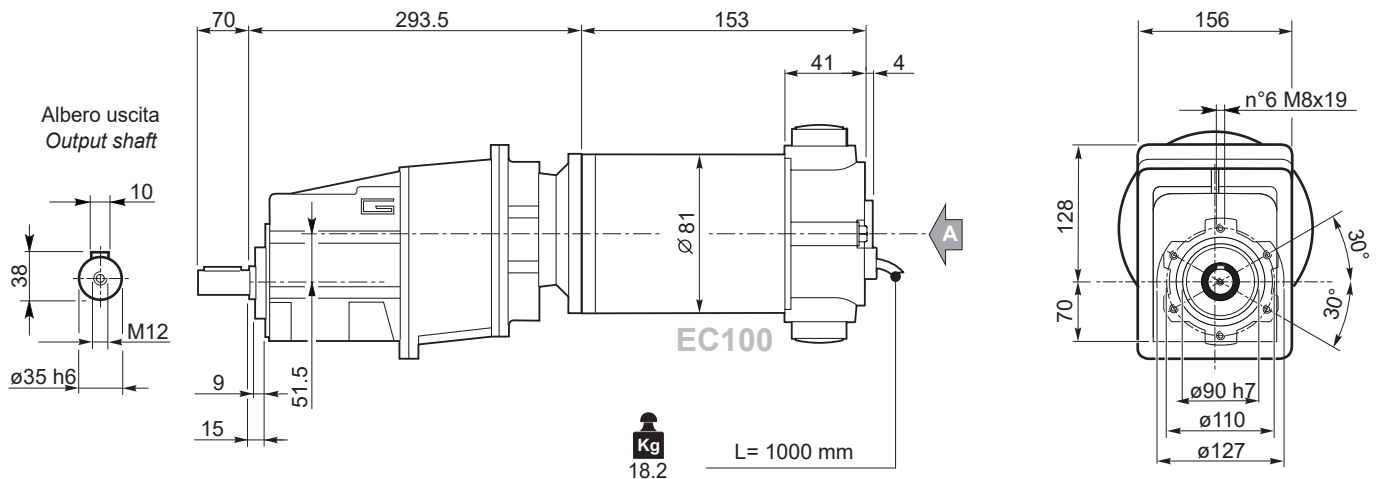

**Nota:** Motore inclinato con portaspazzole a 45°  
**Note:** Motor assembly with brush holder inclined 45°

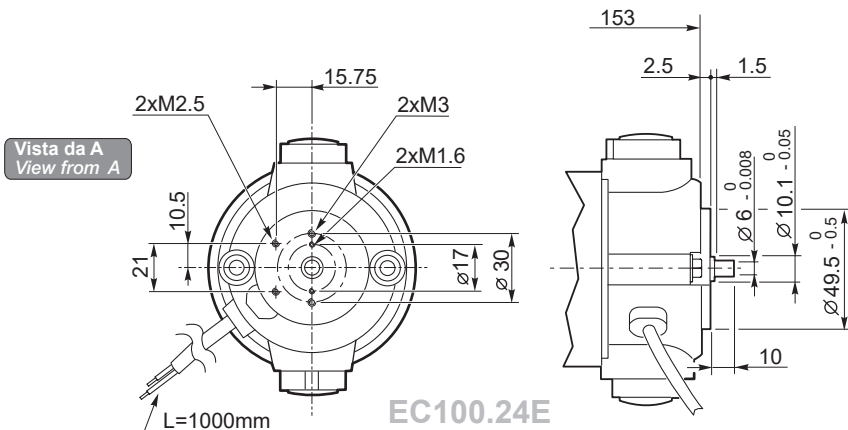

**Nota:** Motore inclinato con portaspazzole a 45°  
**Note:** Motor assembly with brush holder inclined 45°

Freno / Brake → I23

Encoder → I24

Motori / Motors IP66 → L4

ECMG...H → M30

ECMG...F → M31

ECMG...H/F → M32

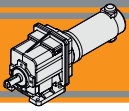

### Dimensioni

### Dimensions

## ECMG..U

### ECMG180/002 U

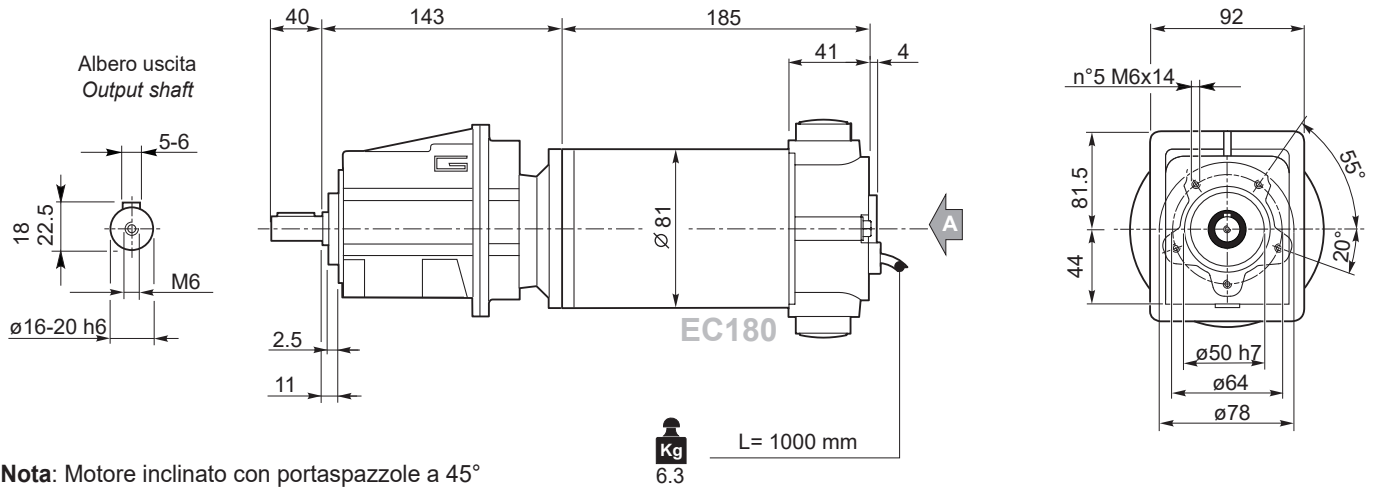

**Nota:** Motore inclinato con portaspazzole a 45°  
**Note:** Motor assembly with brush holder inclined 45°

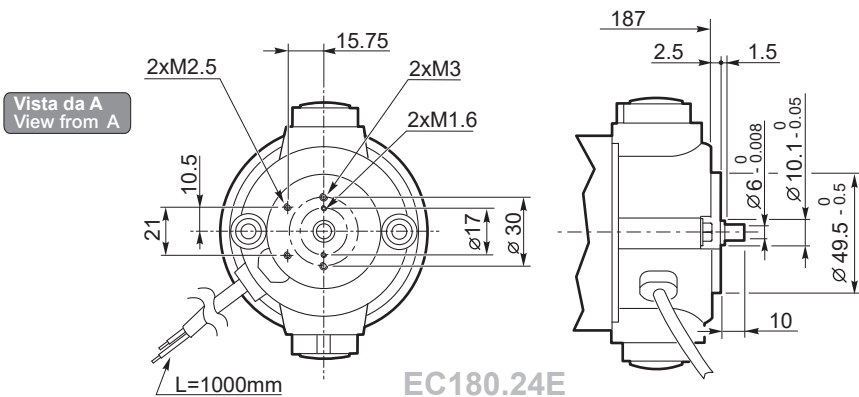

Freno / Brake → I23

Encoder → I24

Motori / Motors IP66 → L6

ECMG...H → M30

ECMG...F → M31

ECMG...H/F → M32

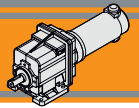

Dimensioni

Dimensions

ECMG..U

ECMG180/012 U

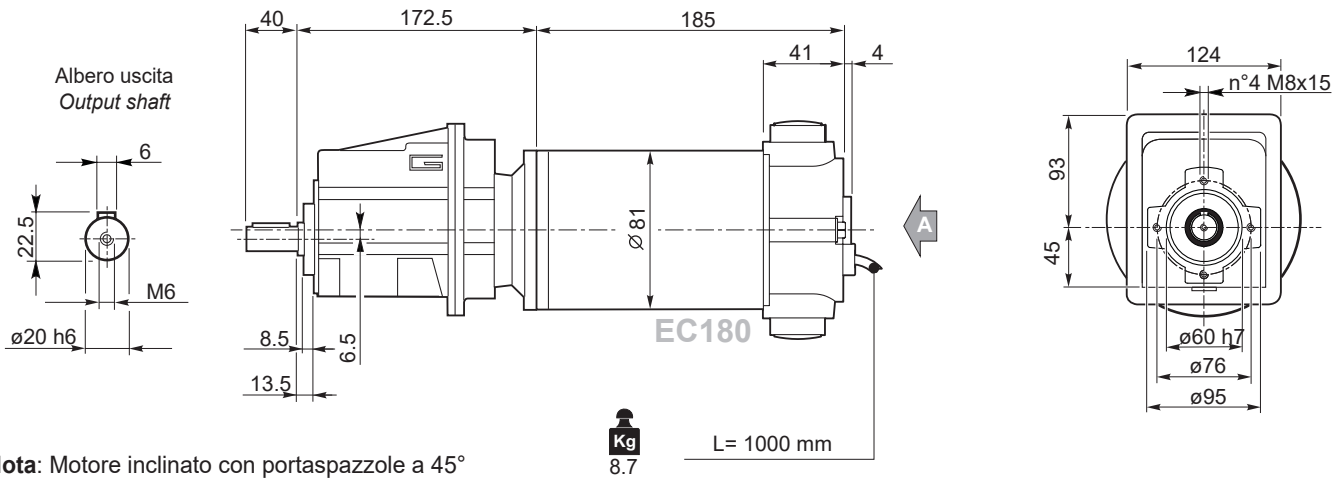

ECMG180/013 U

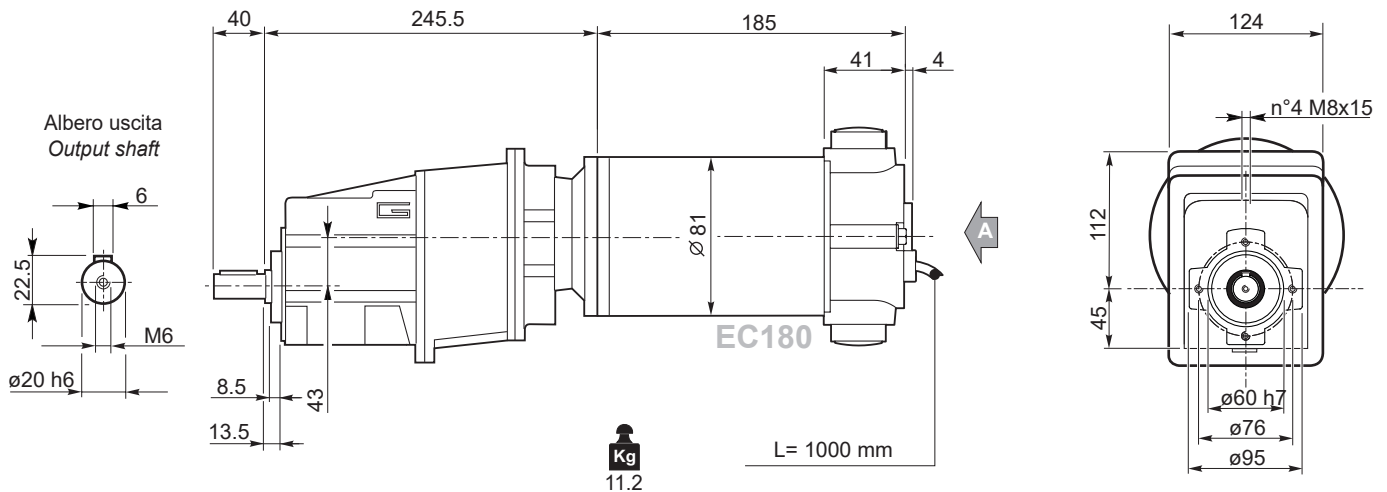

ECMG

Nota: Motore inclinato con portaspazzole a 45°  
Note: Motor assembly with brush holder inclined 45°

Freno / Brake

I23

Encoder

I24

Motori / Motors IP66

L6

ECMG...H

M30

ECMG...F

M31

ECMG...H/F

M32

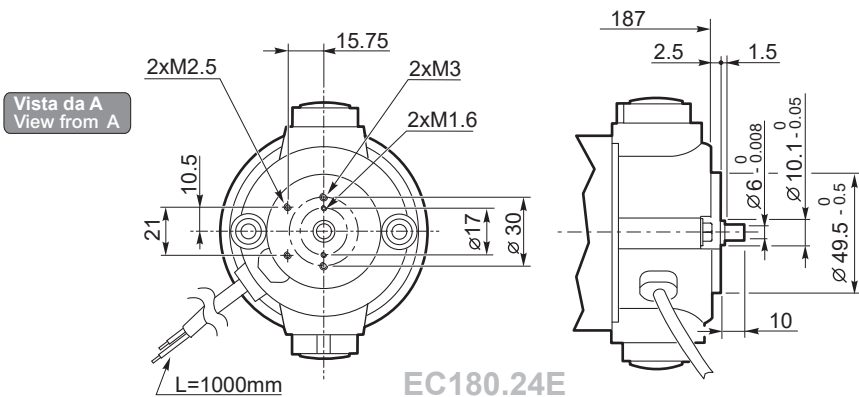

ECMG180.24E

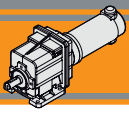

### Dimensioni

### Dimensions

## ECMG..U

### ECMG180/022 U

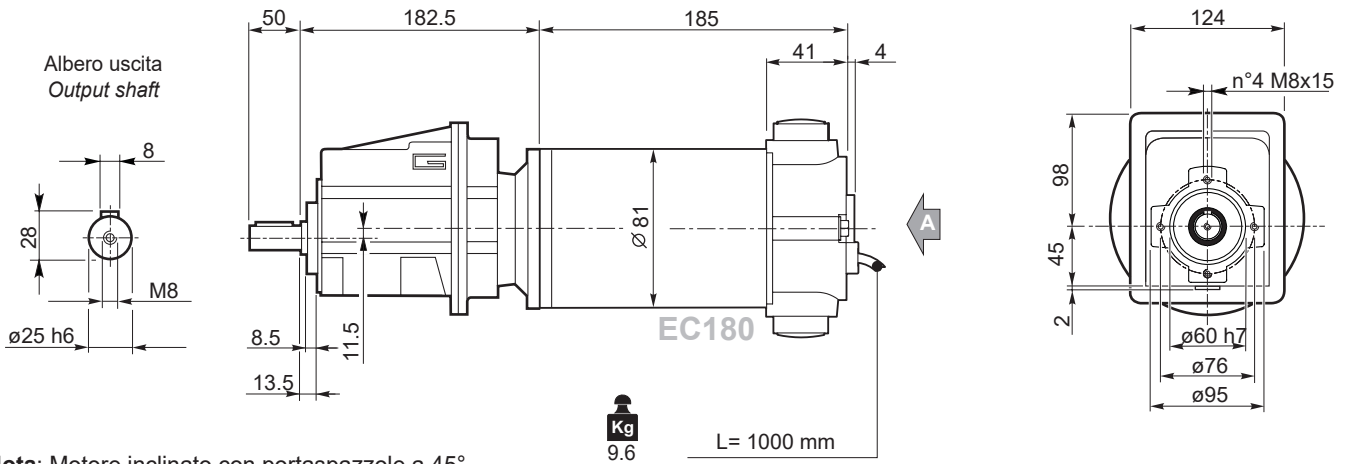

**Nota:** Motore inclinato con portaspazzole a 45°  
**Note:** Motor assembly with brush holder inclined 45°

### ECMG180/023 U

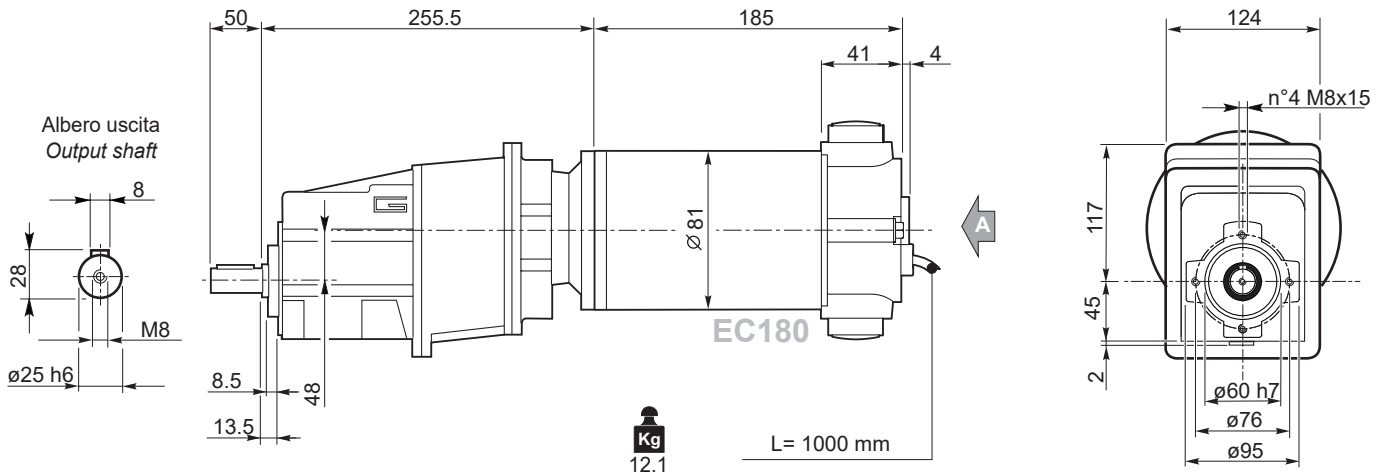

**Nota:** Motore inclinato con portaspazzole a 45°  
**Note:** Motor assembly with brush holder inclined 45°

Freno / Brake → I23

Encoder → I24

Motori / Motors IP66 → L6

ECMG...H → M30

ECMG...F → M31

ECMG...H/F → M32

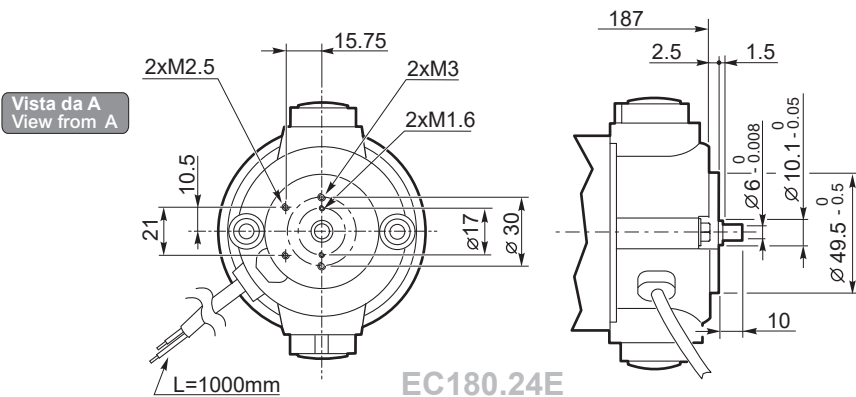

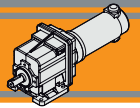

Dimensioni

Dimensions

ECMG..U

ECMG180/033 U

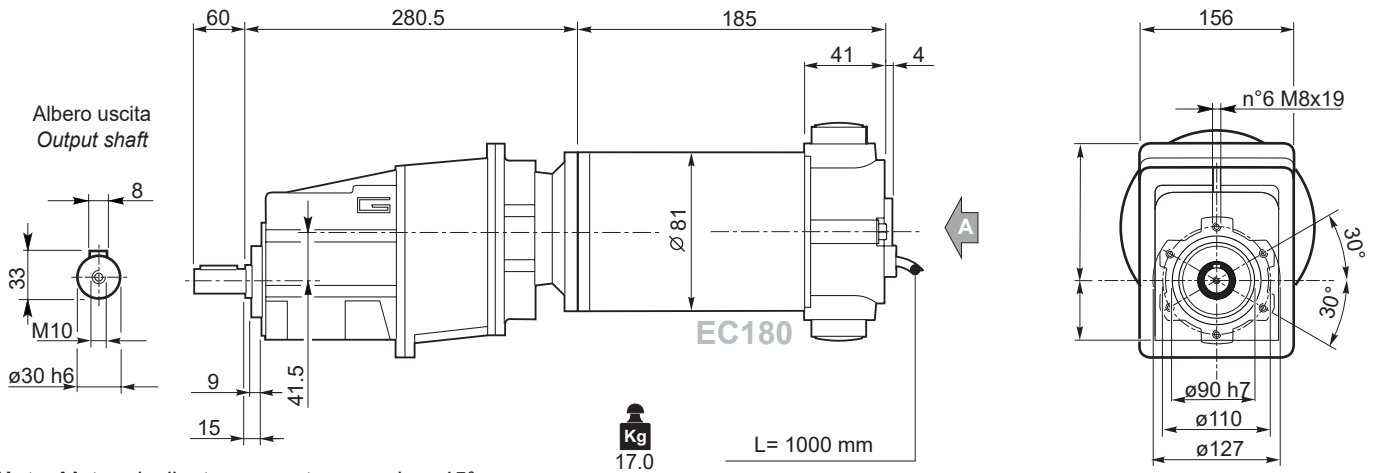

**Nota:** Motore inclinato con portaspazzole a 45°  
**Note:** Motor assembly with brush holder inclined 45°

ECMG180/043 U

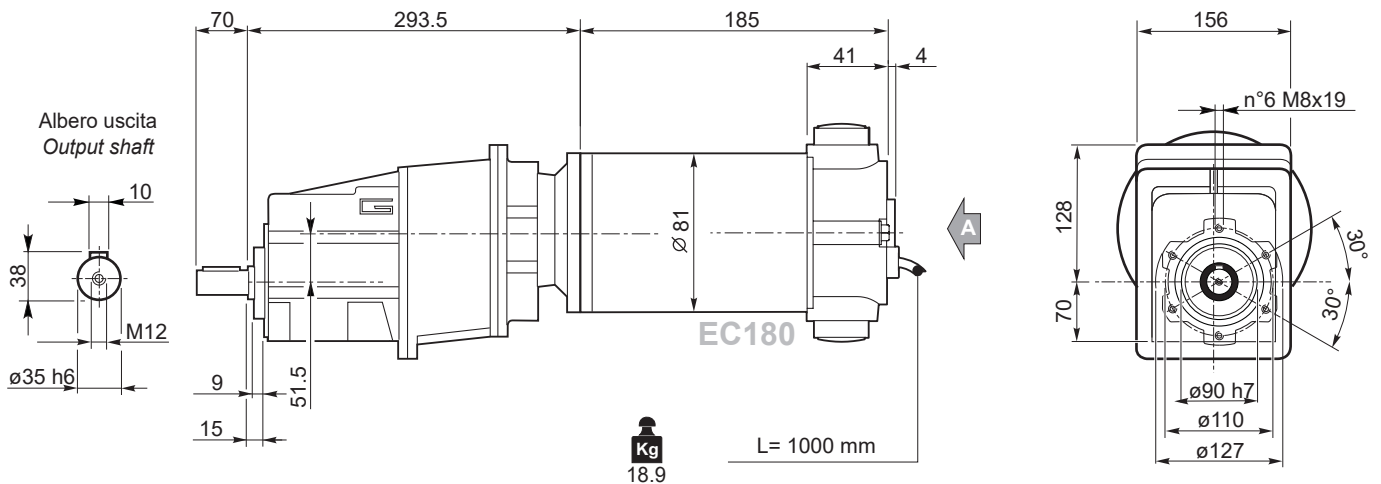

**Nota:** Motore inclinato con portaspazzole a 45°  
**Note:** Motor assembly with brush holder inclined 45°

ECMG

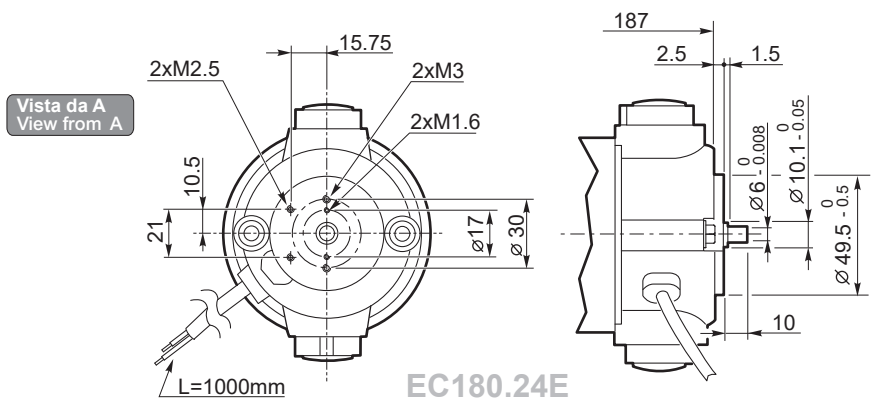

Freno / Brake → I23

Encoder → I24

Motori / Motors IP66 → L6

ECMG...H → M30

ECMG...F → M31

ECMG...H/F → M32

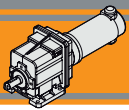

### Dimensioni

### Dimensions

## ECMG..U

### ECMG250/002 U

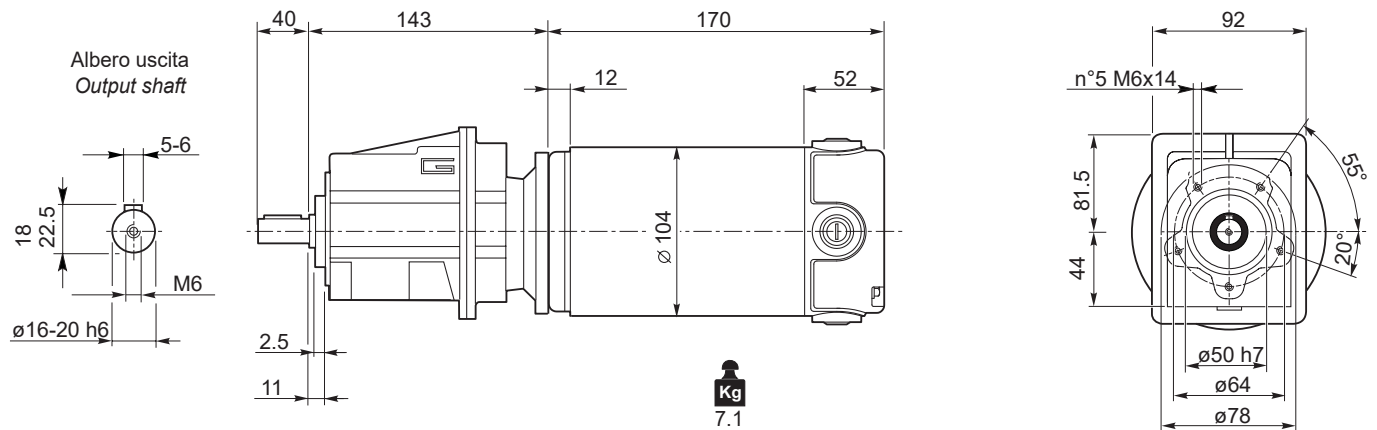

### ECMG250/012 U

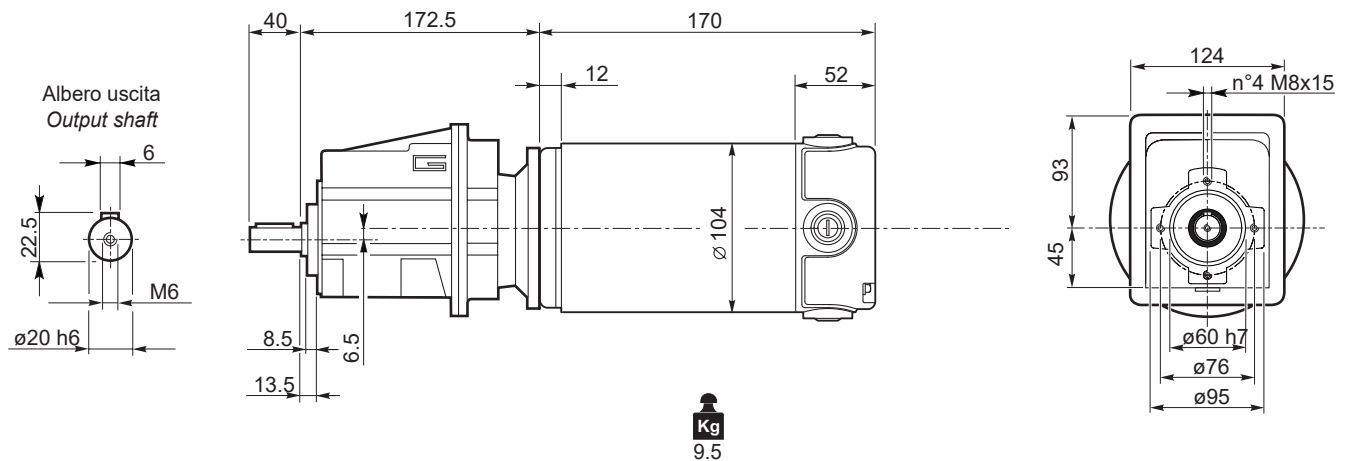

### ECMG250/013 U

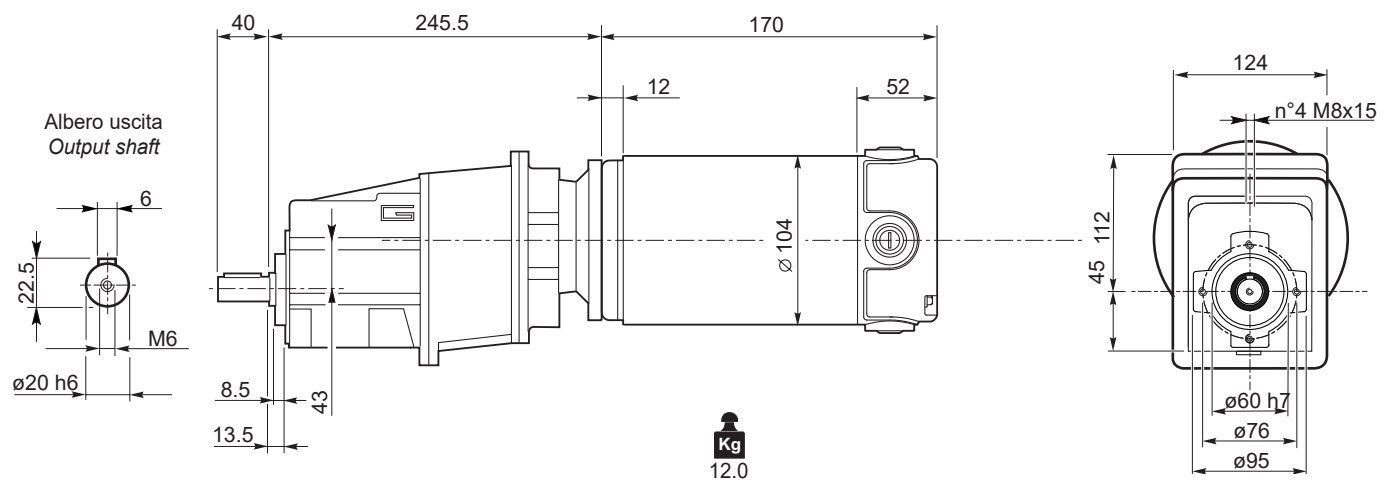

Motori / Motors IP66



ECMG...H



ECMG...F



ECMG...H/F



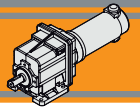

**Dimensioni**

**Dimensions**

**ECMG..U**

**ECMG250/022 U**

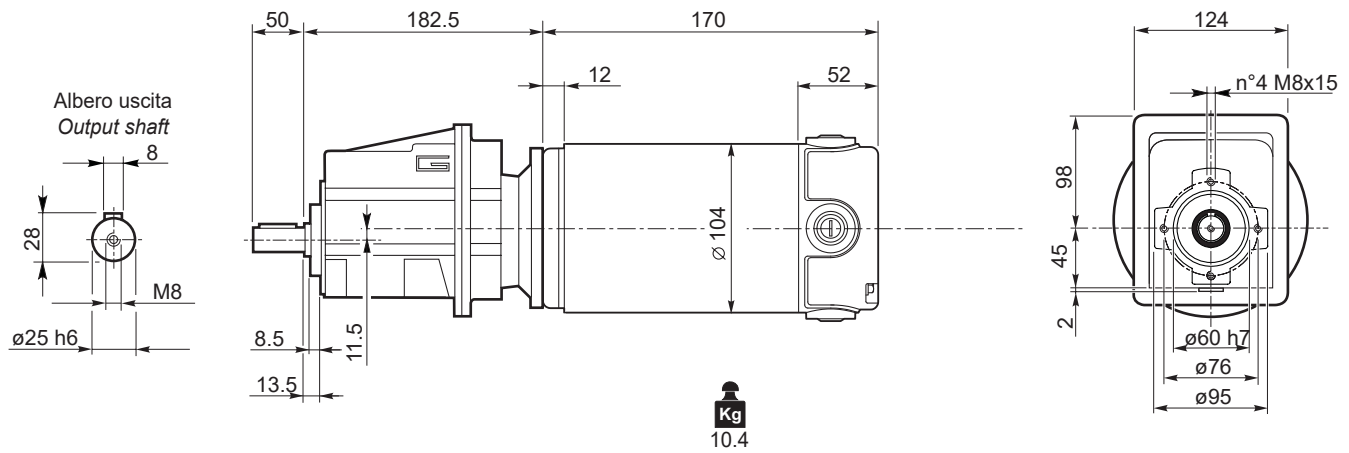

**ECMG250/023 U**

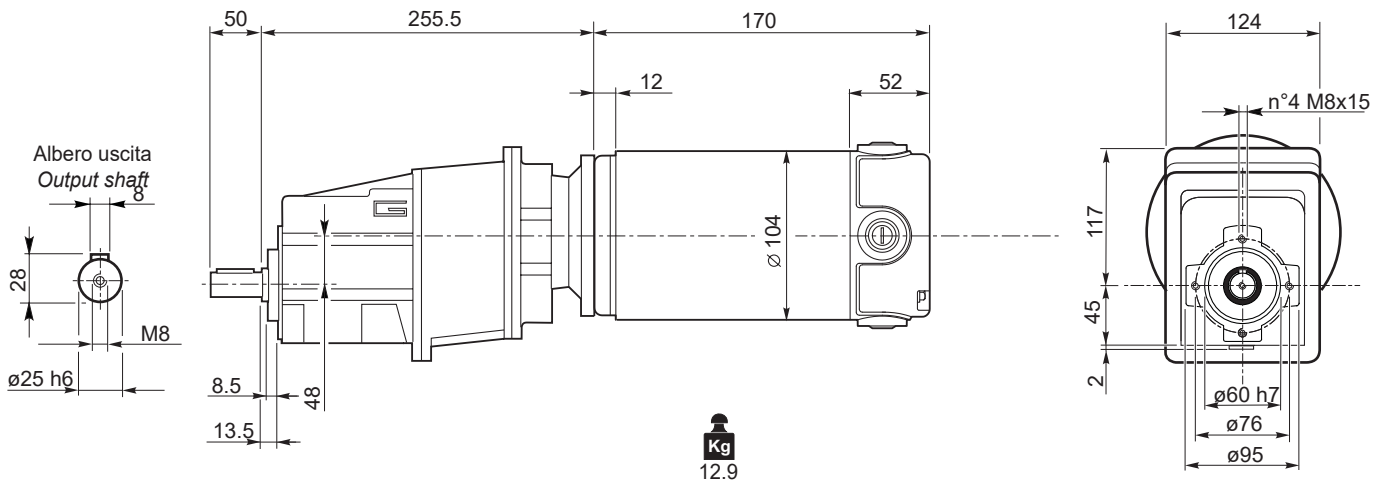

**ECMG**

Motori / Motors IP66



ECMG...H



ECMG...F



ECMG...H/F



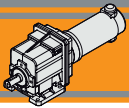

### Dimensioni

### Dimensions

## ECMG..U

### ECMG250/033 U

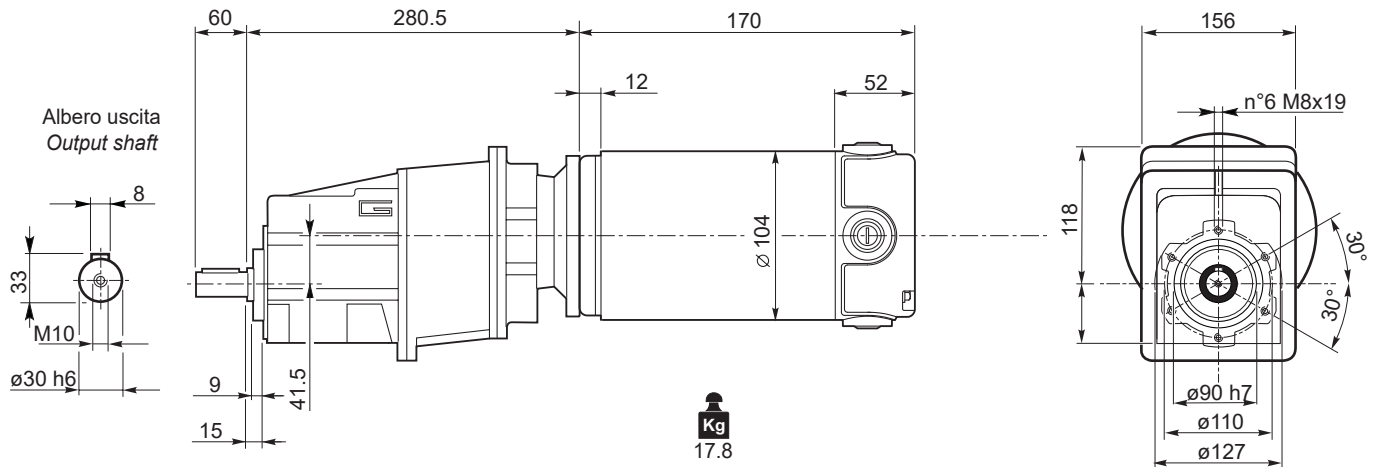

### ECMG250/043 U

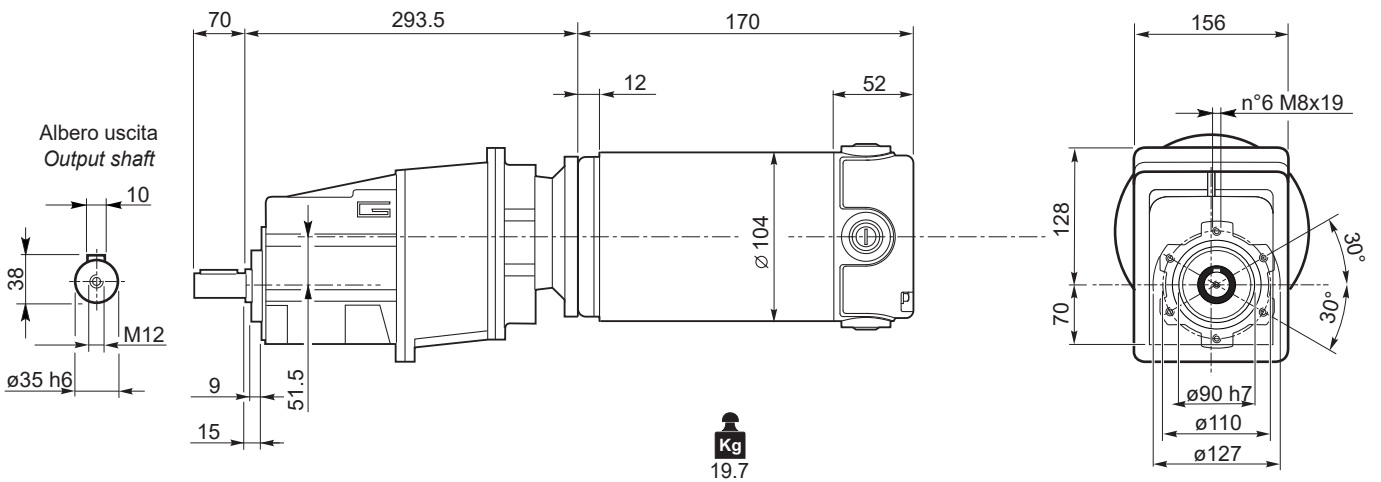

Motori / Motors IP66



ECMG...H



ECMG...F



ECMG...H/F



**Dimensioni**

**Dimensions**

**ECMG..U**

**ECMG350/002 U**

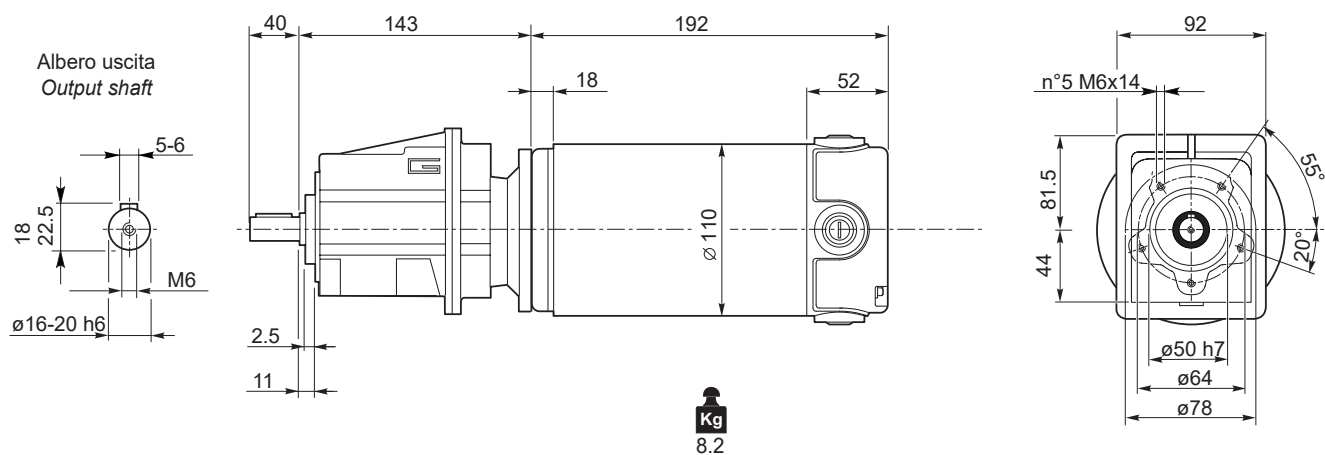

**ECMG350/012 U**

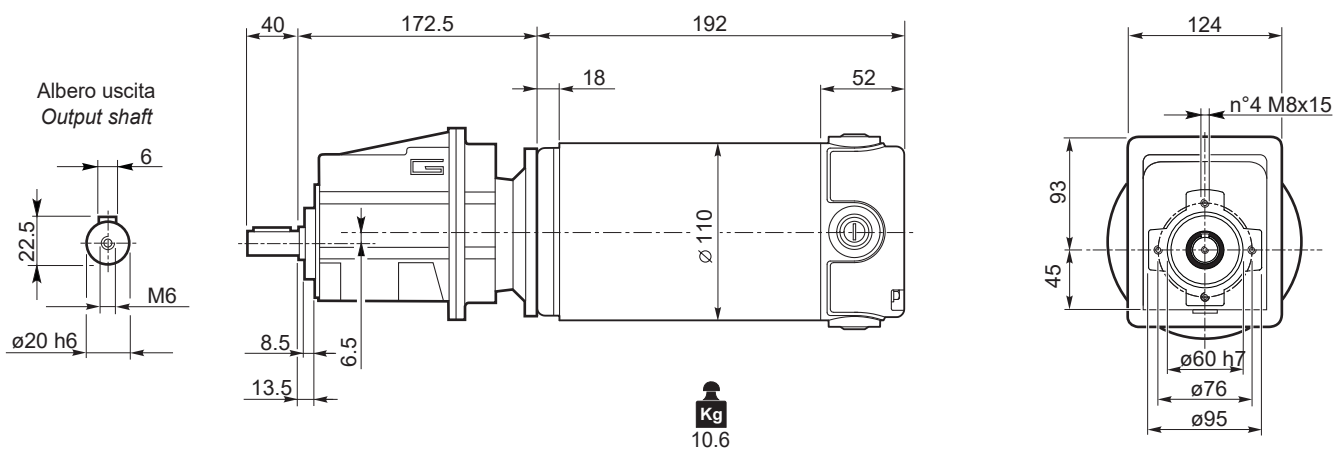

**ECMG350/013 U**

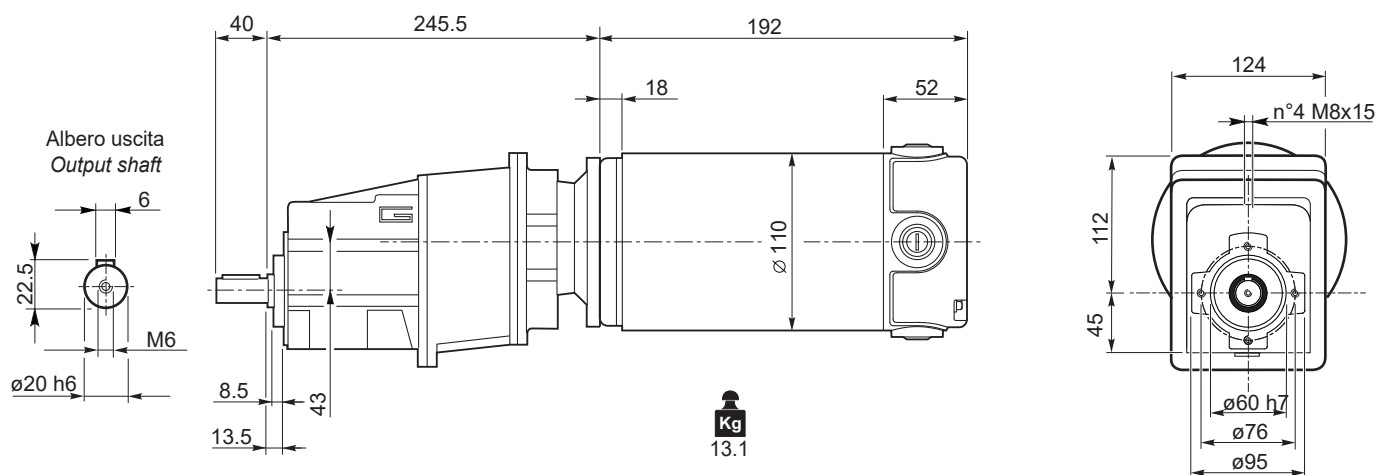

Freno / Brake



I23

Motori / Motors IP66



L10

ECMG...H



M30

ECMG...F



M31

ECMG...H/F



M32

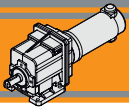

### Dimensioni

### Dimensions

## ECMG..U

### ECMG350/022 U

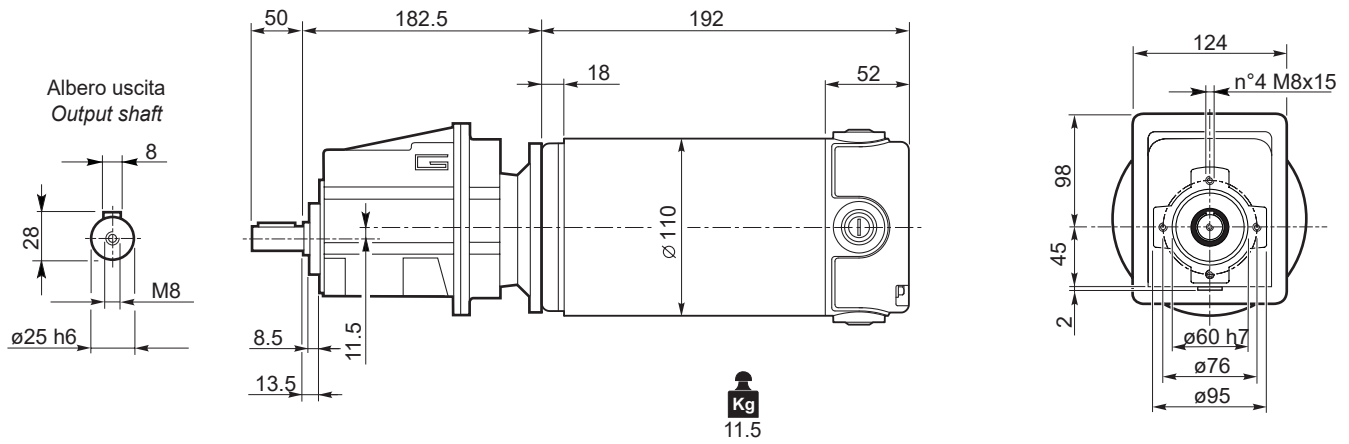

### ECMG350/023 U

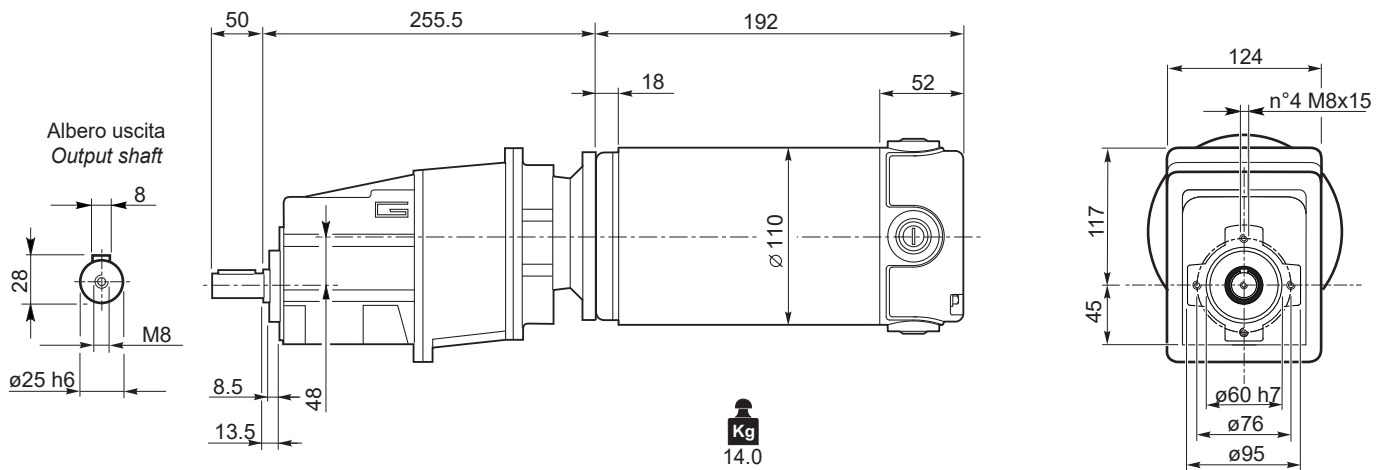

Freno / Brake



ECMG...H



ECMG...F



ECMG...H/F



Motori / Motors IP66



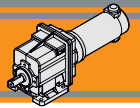

**Dimensioni**

**Dimensions**

**ECMG..U**

**ECMG350/033 U**

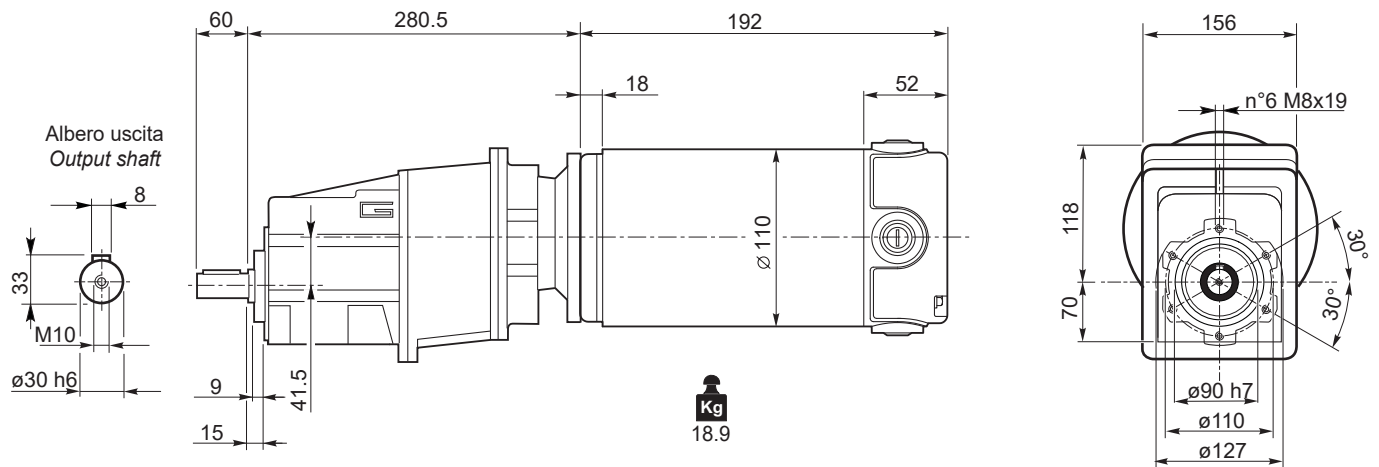

**ECMG350/043 U**

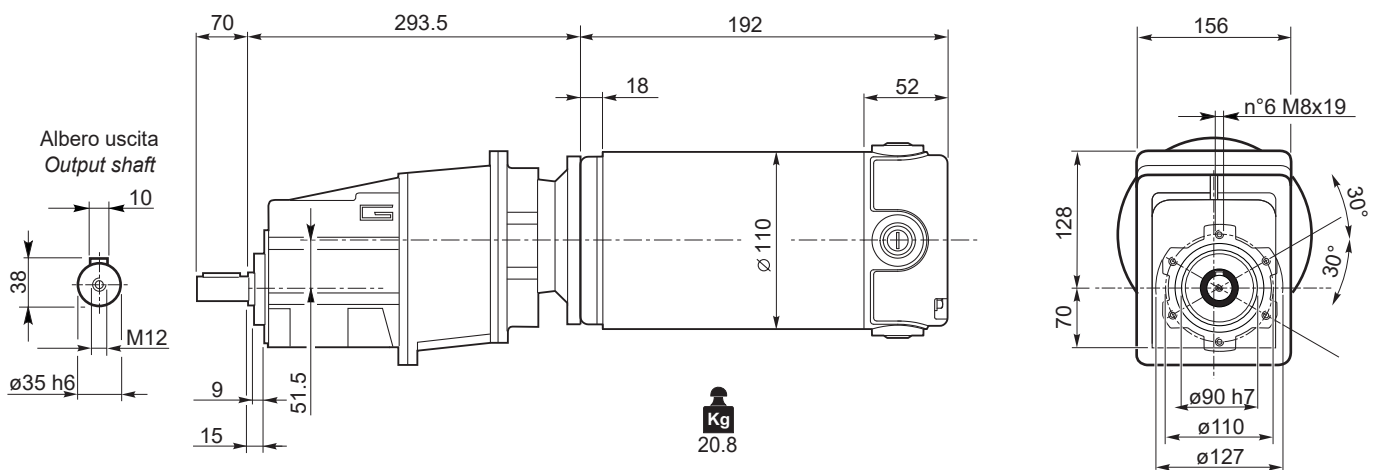

**ECMG**

Freno / Brake



I23

Motori / Motors IP66



L10

ECMG...H



M30

ECMG...F



M31

ECMG...H/F



M32

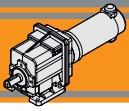

### Dimensioni

### Dimensions

## ECMG..U

### ECMG600/002 U

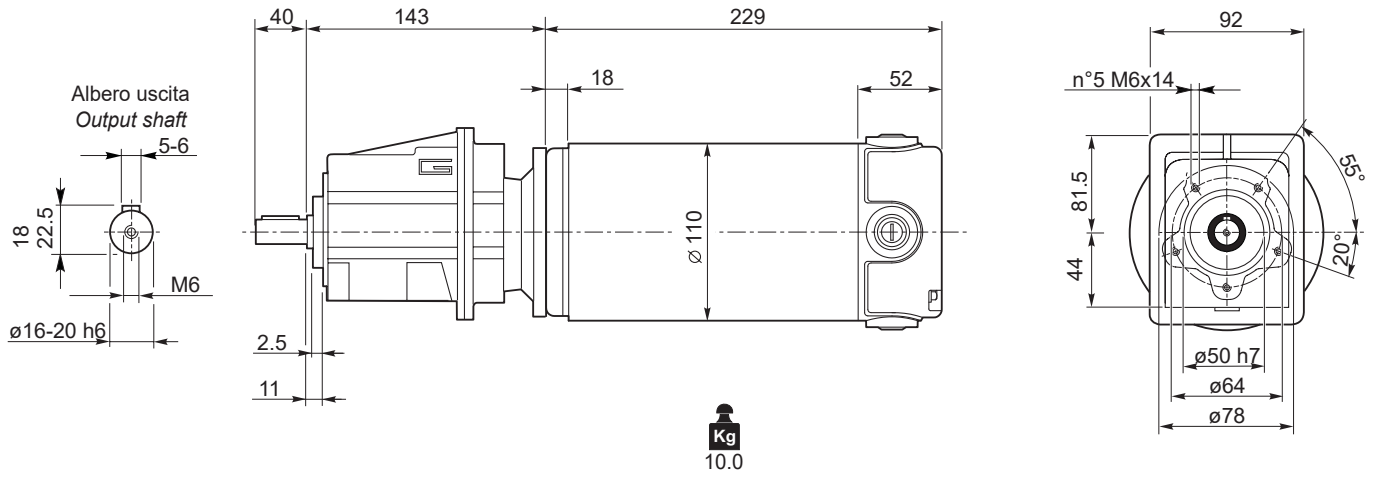

Freno / Brake



Motori / Motors IP66



ECMG...H



ECMG...F



ECMG...H/F



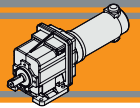

**Dimensioni**

**Dimensions**

**ECMG..U**

**ECMG600/012 U**

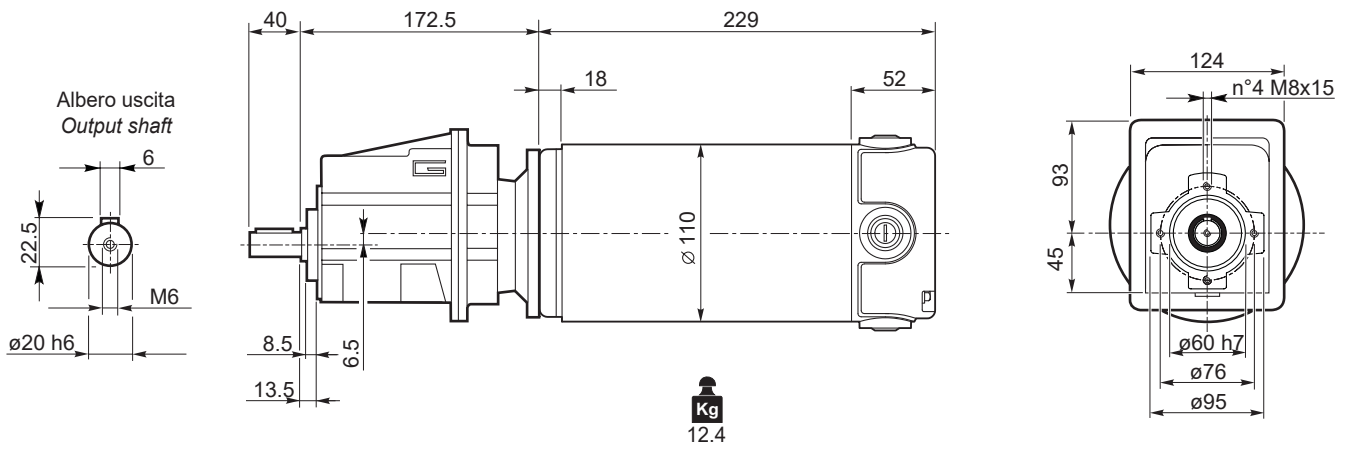

**ECMG600/013 U**

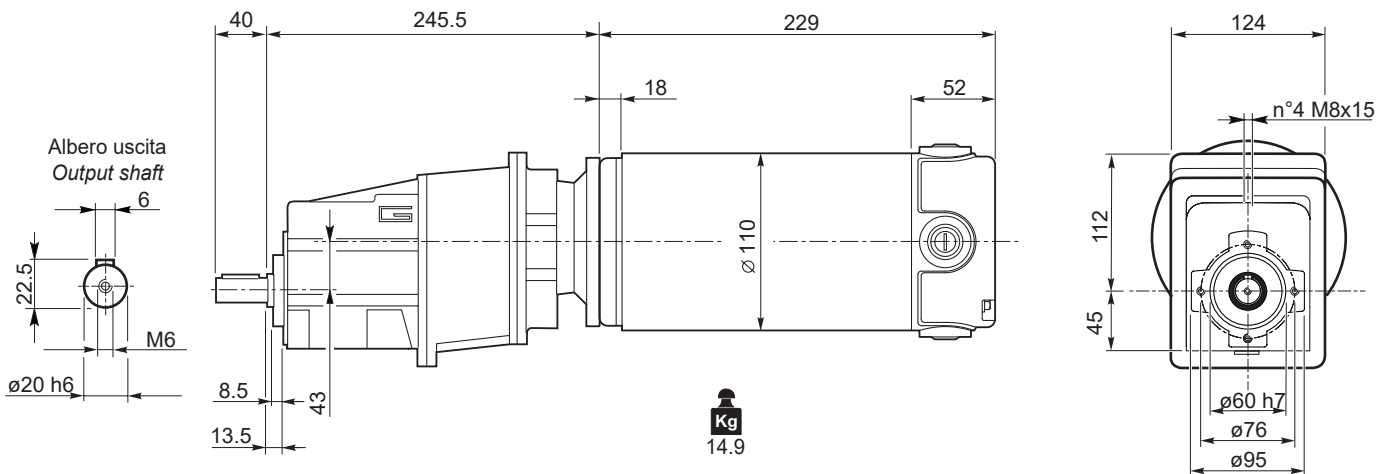

**ECMG**

Freno / Brake



Motori / Motors IP66



ECMG...H



ECMG...F



ECMG...H/F



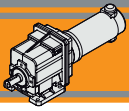

### Dimensioni

### Dimensions

## ECMG..U

### ECMG600/022 U

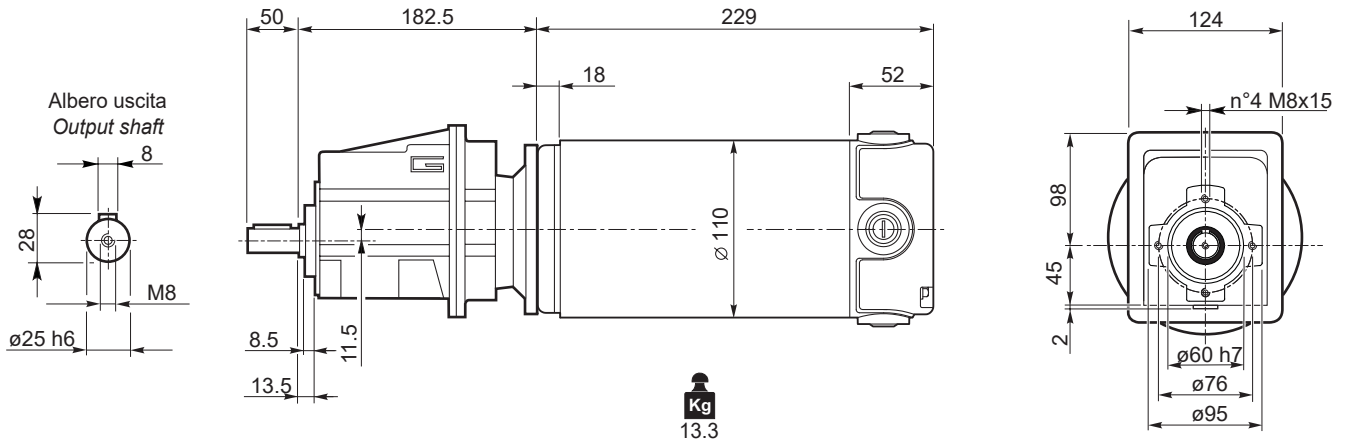

### ECMG600/023 U

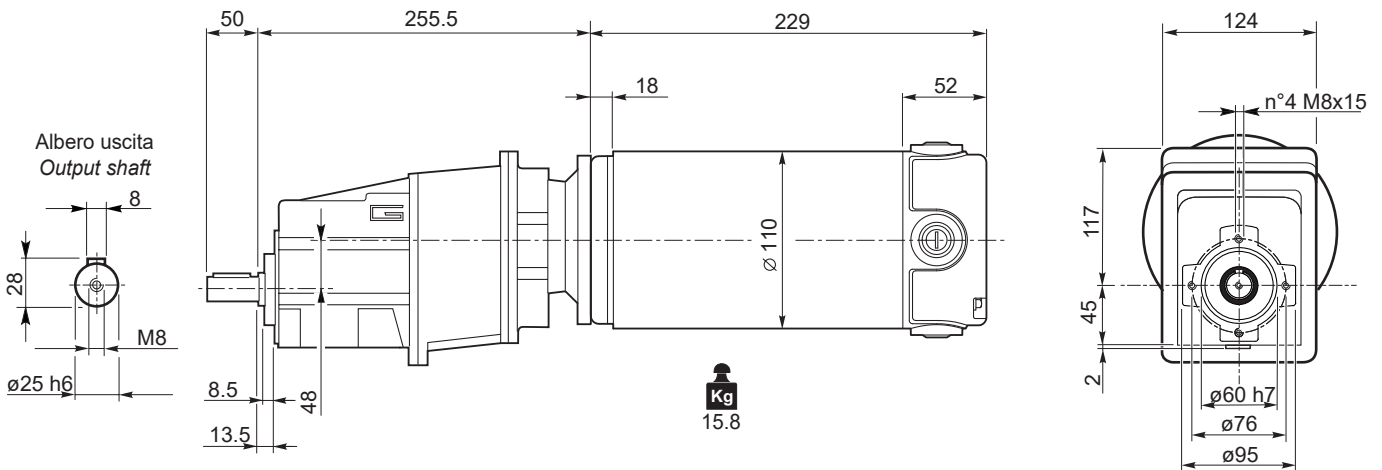

### ECMG600/032 U

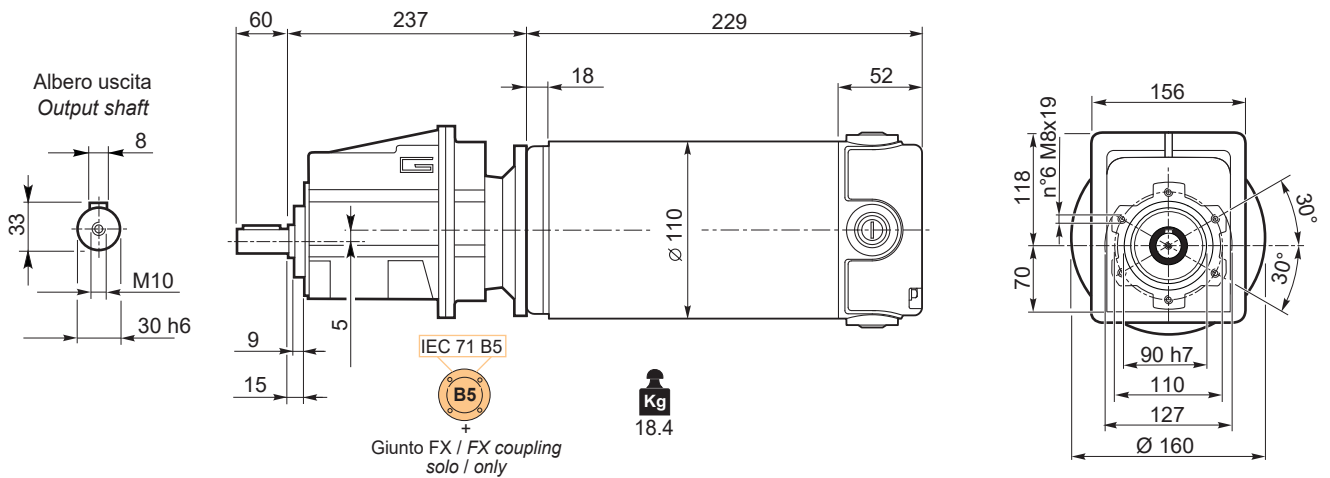

Freno / Brake



I23

ECMG...H



M30

ECMG...F



M31

ECMG...H/F



M32

Motori / Motors IP66



L12

Nota: Motore IP66 non disponibile per ECMG600/032  
Note: IP66 motor not available for ECMG600/032

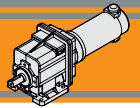

Dimensioni

Dimensions

ECMG..U

ECMG600/033 U

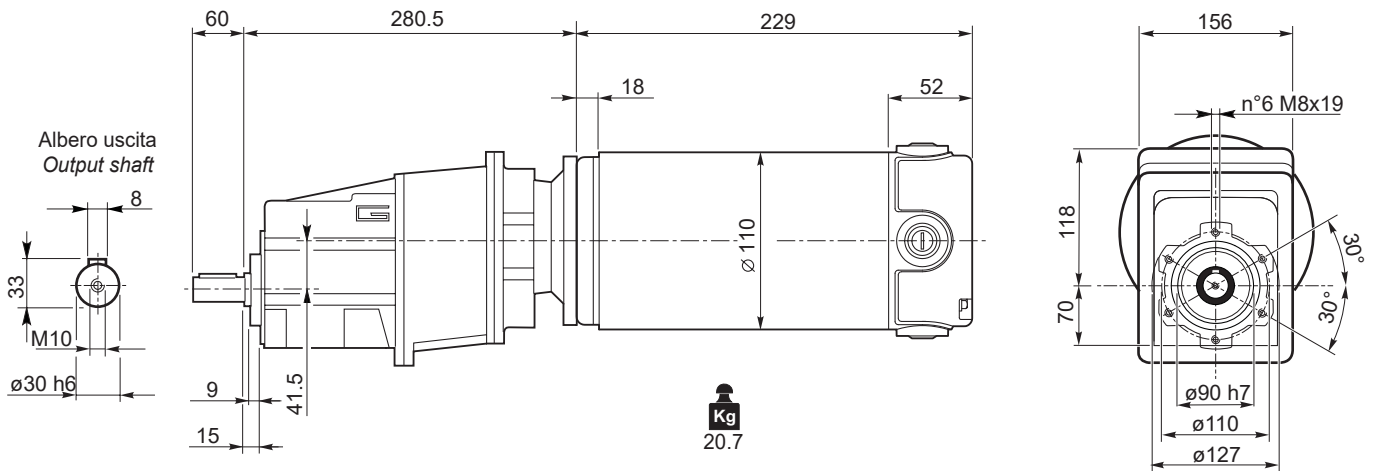

ECMG600/042 U

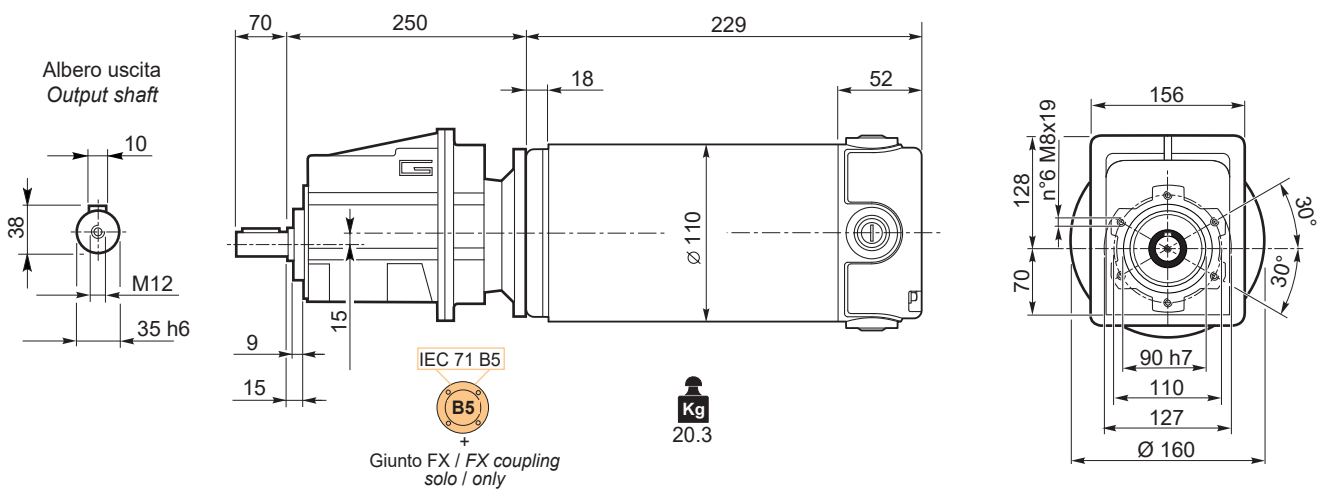

ECMG600/043 U

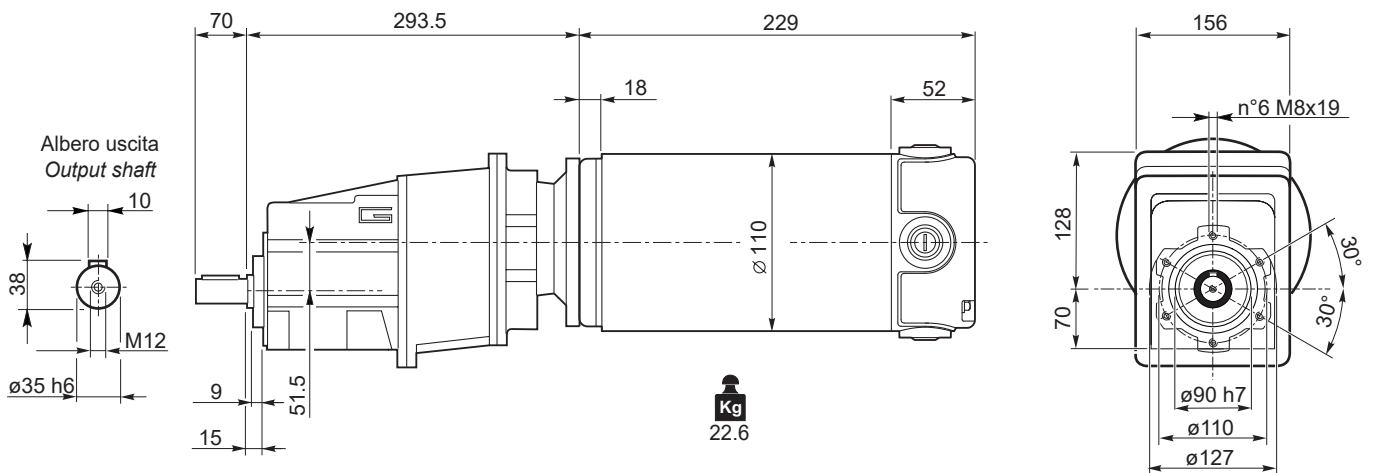

Freno / Brake

I23

ECMG...H

M30

ECMG...F

M31

ECMG...H/F

M32

Motori / Motors IP66

L12

Nota: Motore IP66 non disponibile per ECMG600/042  
Note: IP66 motor not available for ECMG600/042

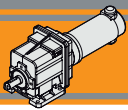

### Dimensioni

### Dimensions

## ECMG..H

### ECMG..2 H..

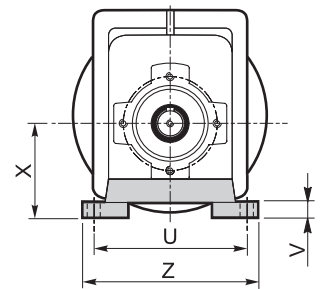
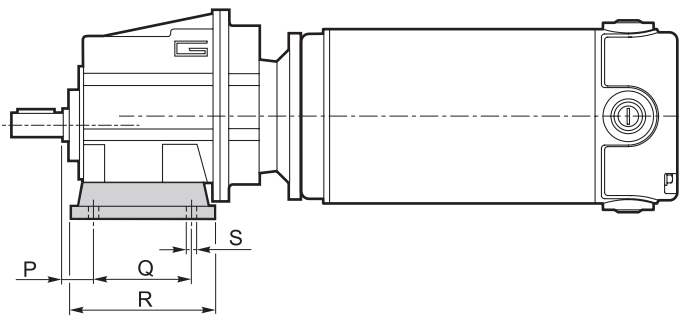

### ECMG..3 H..

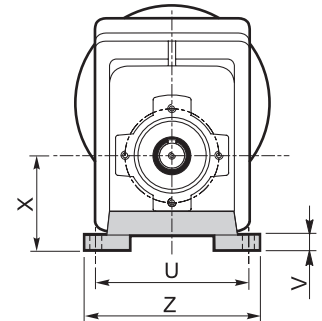
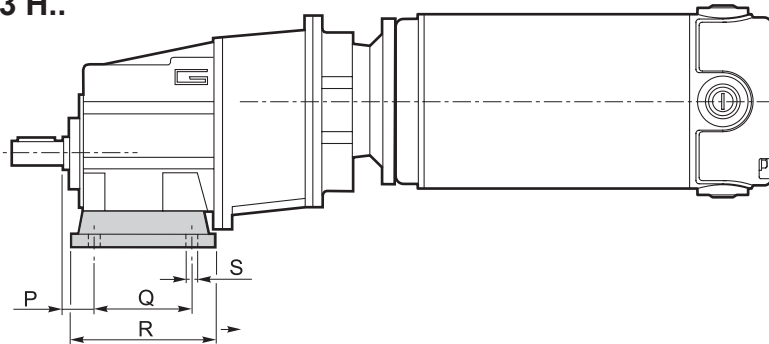

#### Versione H / H Version

CMG	P	Q	R	S	U	V	X	Z	Piede / Foot	
									Tipo / Type	Peso / Weight [kg]
002	18	60	80	9	100	10	60	120	H60	0.2
	18	80	104	9	110 - 120	10	75	145	H75	0.3
	18	50 - 87	110	9	110	10	85	135	H85	0.4
012 013	20	85	108	9	115	12	65	139	H65	0.7
	18	80	118	9	110	12	75	140	H75	1.0
	25	85	120	9	120	12	80	140	H80	1.1
	18	50 - 87	118	9	110	12	85	130	H85	1.2
	25	130	154	9	110	12	90	135	H90	1.5
	18	60 - 107.5	135	11	130	12	100	155	H100	1.7
022 023	20	85	108	9	115	12	65	139	H65	0.7
	18	80	118	9	110	12	75	140	H75	1.0
	25	85	120	9	120	12	80	140	H80	1.1
	18	50 - 87	118	9	110	12	85	130	H85	1.2
	25	130	154	9	110	12	90	135	H90	1.5
	18	60 - 107.5	135	11	130	12	100	155	H100	1.7
032 033	30	105	136	14	160	14	95	194	H95	1.5
	30	100	150	11	150	14	110	185	H110	1.9
	18	70			160					
	30	165	195	14	135	14	115	170	H115	2.2
	35	110	160	14	170	14	120	210	H120	2.6
042 043	30	105	136	14	160	14	95	194	H95	1.5
	30	100	150	11	150	14	110	185	H110	1.9
	18	70			160					
	30	165	195	14	135	14	115	170	H115	2.2
	35	110	160	14	170	14	120	210	H120	2.6

Preferenziale / Preferred

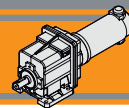

Dimensioni

Dimensions

**ECMG..F**

**ECMG..2 F..**

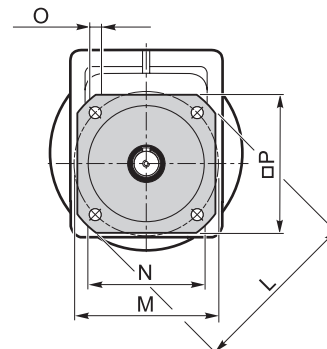
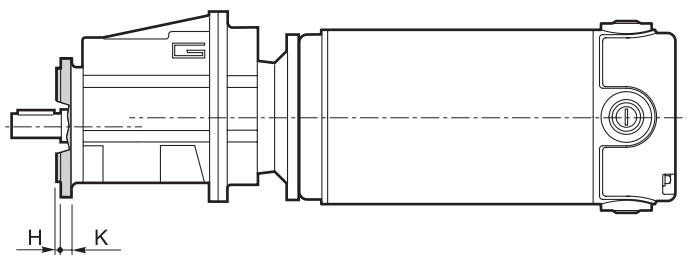

**ECMG..3 F..**

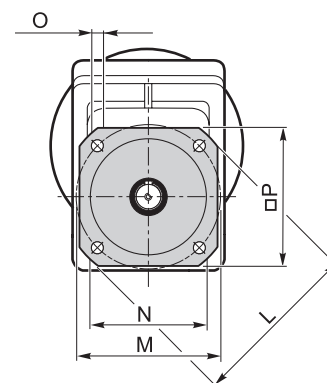
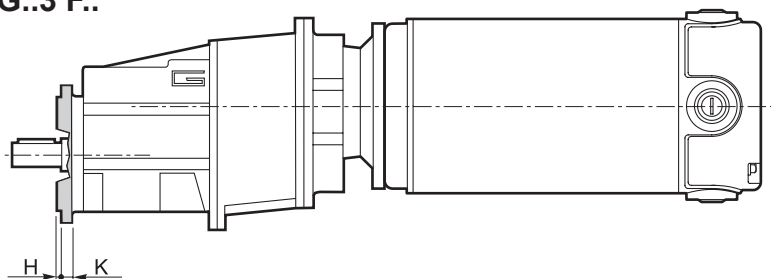

Versione F / F Version									
CMG	H	K	L	M	N f7	O	P	Flangia / Flange	
								Tipo / Type	Peso / Weight [kg]
<b>002</b>	3.5	7	105	85	70	6.5	90	<b>F105</b>	0.1
	3.5	8	120	100	80	7	100	<b>F120</b>	0.2
	3.5	8	140	115	95	9	115	<b>F140</b>	0.2
<b>012</b> <b>013</b>	3	9	120	100	80	9	106	<b>F120</b>	0.5
	3.5	9	140	115	95	9	115	<b>F140</b>	0.8
	3.5	9	160	130	110	9	126	<b>F160</b>	1.1
	3.5	11	200	165	130	11	165	<b>F200</b>	1.8
<b>022</b> <b>023</b>	3	9	120	100	80	9	106	<b>F120</b>	0.5
	3.5	9	140	115	95	9	115	<b>F140</b>	0.8
	3.5	9	160	130	110	9	126	<b>F160</b>	1.1
	3.5	11	200	165	130	11	165	<b>F200</b>	1.8
<b>032</b> <b>033</b>	3.5	11	160	130	110	9	140	<b>F160</b>	1.0
	3.5	11	200	165	130	11	165	<b>F200</b>	1.8
	4	13	250	215	180	14	215	<b>F250</b>	2.9
<b>042</b> <b>043</b>	3.5	11	160	130	110	9	140	<b>F160</b>	1.0
	3.5	11	200	165	130	11	165	<b>F200</b>	1.8
	4	13	250	215	180	14	215	<b>F250</b>	2.9

**ECMG**

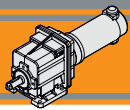

### Dimensioni

### Dimensions

Versione H / H Version											Combinazioni possibili H/F Possible combinations H/F						
CMG	P	Q	R	S	U	V	X	Z	Piede / Foot		F105	F120	F140	F160	F200	F250	F300
									Tipo / Type	Peso / Weight [kg]							
002	18	60	80	9	100	10	60	120	H60	0.2	•	•	•				
	18	80	104	9	110 - 120	10	75	145	H75	0.3	•	•	•				
	18	50 - 87	110	9	110	10	85	135	H85	0.4	•	•	•				
012 013	20	85	108	9	115	12	65	139	H65	0.7		•	•				
	18	80	118	9	110	12	75	140	H75	1.0		•	•	•			
	25	85	120	9	120	12	80	140	H80	1.1		•	•	•			
	18	50 - 87	118	9	110	12	85	130	H85	1.2		•	•	•			
	25	130	154	9	110	12	90	135	H90	1.5		•	•	•	•		
	18	60 - 107.5	135	11	130	12	100	155	H100	1.7		•	•	•	•		
022 023	20	85	108	9	115	12	65	139	H65	0.7		•	•				
	18	80	118	9	110	12	75	140	H75	1.0		•	•	•			
	25	85	120	9	120	12	80	140	H80	1.1		•	•	•			
	18	50 - 87	118	9	110	12	85	130	H85	1.2		•	•	•			
	25	130	154	9	110	12	90	135	H90	1.5		•	•	•	•		
	18	60 - 107.5	135	11	130	12	100	155	H100	1.7		•	•	•	•		
032 033	30	105	136	14	160	14	95	194	H95	1.5				•	•		
	30	100	150	11	150	14	110	185	H110	1.9				•	•		
	18	70			160												
	30	165	195	14	135	14	115	170	H115	2.2				•	•	•	
	35	110	160	14	170	14	120	210	H120	2.6				•	•	•	
042 043	30	105	136	14	160	14	95	194	H95	1.5				•	•		
	30	100	150	11	150	14	110	185	H110	1.9				•	•		
	18	70			160												
	30	165	195	14	135	14	115	170	H115	2.2				•	•	•	
	35	110	160	14	170	14	120	210	H120	2.6				•	•	•	

■ Preferenziale / Preferred

• Combinazioni possibili H/F / Possible combinations H/F

Versione F / F Version									
CMG	H	K	L	M	N f7	O	P	Flangia / Flange	
								Tipo / Type	Peso / Weight [kg]
002	3.5	7	105	85	70	6.5	90	F105	0.1
	3.5	8	120	100	80	7	100	F120	0.2
	3.5	8	140	115	95	9	115	F140	0.2
012 013	3	9	120	100	80	9	106	F120	0.5
	3.5	9	140	115	95	9	115	F140	0.8
	3.5	9	160	130	110	9	126	F160	1.1
	3.5	11	200	165	130	11	165	F200	1.8
022 023	3	9	120	100	80	9	106	F120	0.5
	3.5	9	140	115	95	9	115	F140	0.8
	3.5	9	160	130	110	9	126	F160	1.1
	3.5	11	200	165	130	11	165	F200	1.8
032 033	3.5	11	160	130	110	9	140	F160	1.0
	3.5	11	200	165	130	11	165	F200	1.8
	4	13	250	215	150	14	215	F250	2.9
042 043	3.5	11	160	130	110	9	140	F160	1.0
	3.5	11	200	165	130	11	165	F200	1.8
	4	13	250	215	150	14	215	F250	2.9

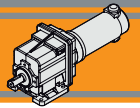

Dimensioni

Dimensions

**ECMG..H../F..**

**ECMG..2 H../F..**

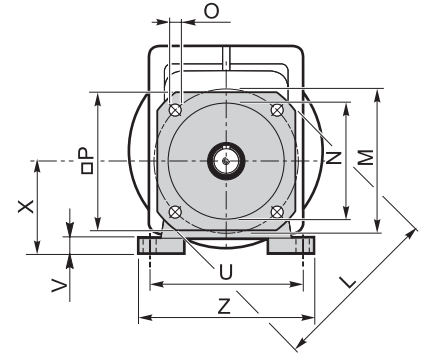
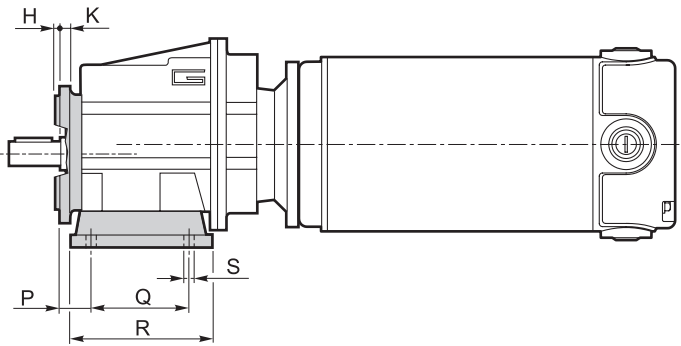

**ECMG..3 H../F..**

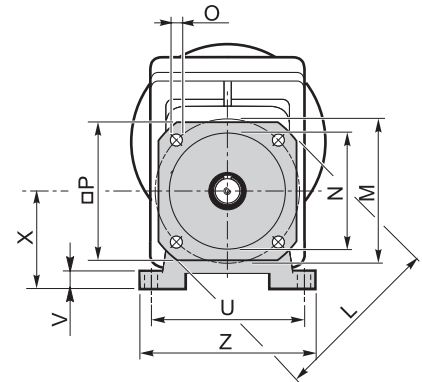
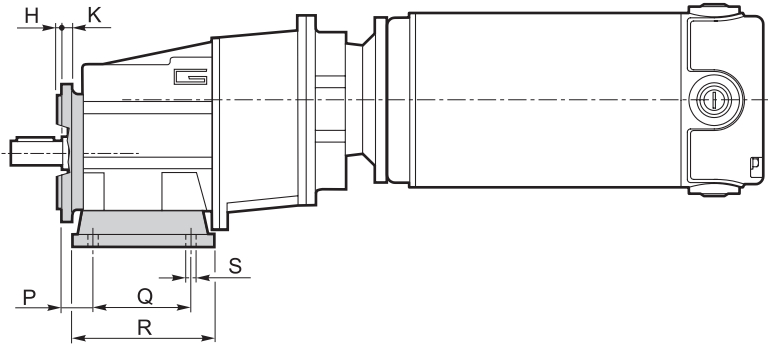





Ferrite

Motoriduttori CC ad assi ortogonali  
**DC helical bevel gearmotors**

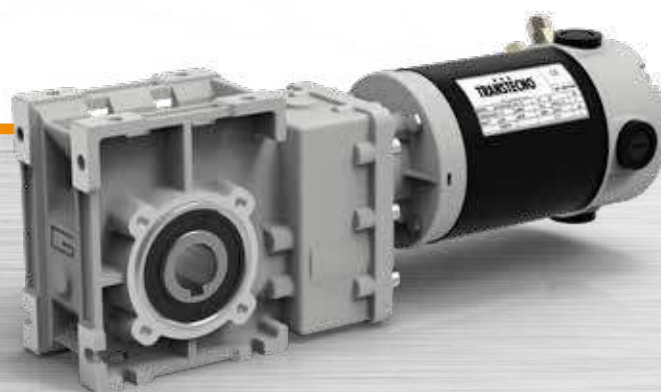



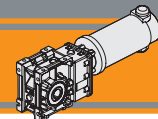

Pag.  
Page



**Indice**

Caratteristiche tecniche  
Designazione  
Sensi di rotazione  
Simbologia  
Lubrificazione  
Carichi radiali  
Dati tecnici per servizio S2  
Motori applicabili  
Dimensioni  
Accessori

**Index**

*Technical features*  
*Classification*  
*Direction of rotation*  
*Symbols*  
*Lubrication*  
*Radial loads*  
*Technical data for S2 duty*  
*Motor adapters*  
*Dimensions*  
*Accessories*

**N2**  
**N2**  
**N2**  
**N3**  
**N3**  
**N3**  
**N4**  
**N6**  
**N7**  
**N18**

Questa sezione annulla e sostituisce ogni precedente edizione o revisione. Qualora questa sezione non Vi sia giunta in distribuzione controllata, l'aggiornamento dei dati ivi contenuto non è assicurato. **In tal caso la versione più aggiornata è disponibile sul nostro sito internet [www.transtecno.com](http://www.transtecno.com)**

*This section replaces any previous edition and revision. If you obtained this catalogue other than through controlled distribution channels, the most up to date content is not guaranteed. In this case the latest version is available on our web site [www.transtecno.com](http://www.transtecno.com)*

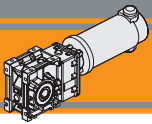

### Caratteristiche tecniche

### Technical features

Le caratteristiche principali dei motoriduttori CC ad assi ortogonali a magneti permanenti in ferrite serie ECMB sono:

The main features of ECMB ferrite permanent magnets DC helical bevel gearmotors range are:

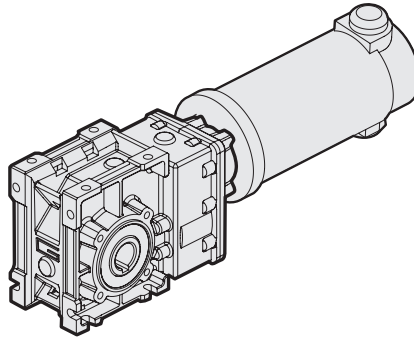

- Alimentazione in bassa tensione 12/24 Vcc
- Possibilità di montaggio encoder
- Potenze motore disponibili da 100 a 800W S2
- Magneti in ferrite
- Carcasse dei riduttori in pressofusione di alluminio
- Lubrificazione permanente con olio sintetico
- Ingranaggi sempre rettificati
- Disponibili con giunto elastico in entrata

- Low voltage power supply 12/24 Vdc
- Suitable for encoder assembly
- Motor power ratings available from 100 to 800W S2
- Ferrite magnets
- Die-cast aluminum housing
- Permanent synthetic oil long-life lubrication
- Ground helical gears
- Input flexible coupling available

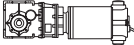

### Designazione

### Classification

MOTORIDUTTORE / GEARMOTOR														
ECMB	100/402						U	9.2	D20	SZDX	BRSX	90	240	FX
Typo	Grandezza						Versione Riduttore Gearbox Version	Rapporto Ratio	Albero di uscita Output shaft	Albero di uscita Output shaft	Braccio di reazione Torque arm	Angolo Angle	Versione Motore Motor Version	Giunto elastico Flexible coupling
	070/402	100/402	180/402	250/402	350/402	600/402	U	Vedere tabella See tables	Vedere tabella See tables	SZDX SZSX DZ	BRDX BR SX	0° 90° 180° 270°	120 240 24E	
	070/502	100/502	180/502	250/502	350/502	600/502	FD							
	070/633	100/633	180/633	250/633	350/633	600/903	FS FLD FLS FBD FBS							

Versione Riduttore  
Gearbox Version

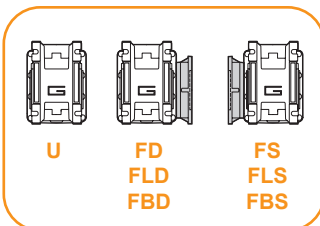

Albero di uscita  
Output shaft

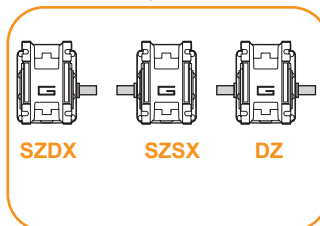

Braccio di reazione  
Torque arm \*

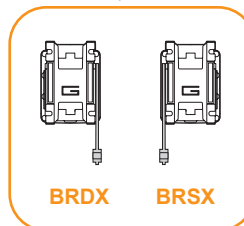

Angolo  
Angle

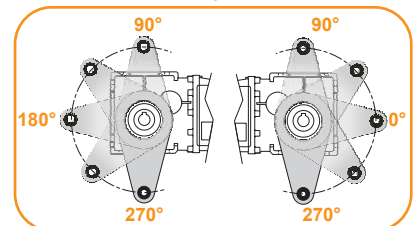

\* NOTA: il braccio di reazione viene fornito smontato.  
NOTE: the torque arm will be supplied not assembled.

### Sensi di rotazione

### Direction of rotation

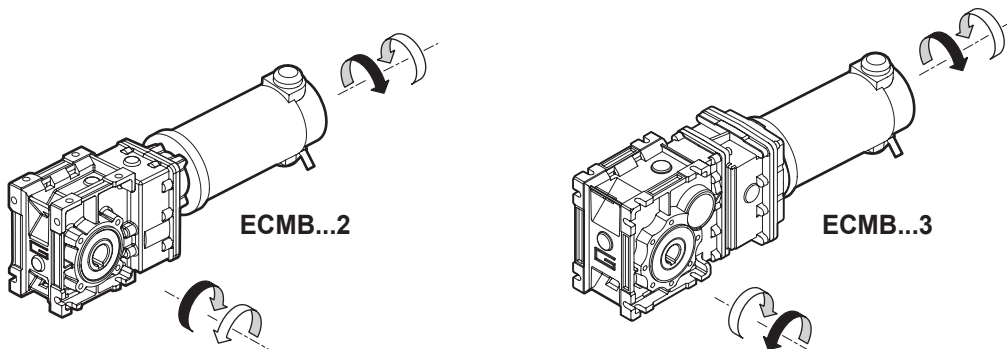

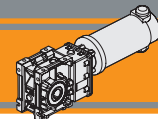

**Simbologia**

**Symbols**

$n_1$ [min <sup>-1</sup> ]	Velocità in ingresso / <i>Input speed</i>	$M_2$ [Nm]	Coppia in uscita in funzione di $P_1$ / <i>Output torque referred to <math>P_1</math></i>
$n_2$ [min <sup>-1</sup> ]	Velocità in uscita / <i>Output speed</i>	sf	Fattore di servizio / <i>Service factor</i>
i	Rapporto di riduzione / <i>Ratio</i>	$A_2$ [N]	Carico assiale ammissibile in uscita / <i>Permitted output axial load</i>
$P_1$ [kW]	Potenza in entrata / <i>Input power</i>	$R_2$ [N]	Carico radiale ammissibile in uscita / <i>Permitted output radial load</i>

**Lubrificazione**

**Lubrication**

Tutti i riduttori nelle taglie 402, 502 e 633 sono forniti completi di lubrificante sintetico viscosità 320, pertanto possono essere installati in qualunque posizione di montaggio e non necessitano di manutenzione.

*Permanent synthetic oil long-life lubrication (viscosity grade 320) makes it possible to use sizes 402, 502 and 603 in all mounting positions; for this reason they can be installed in any assembly position and do not require maintenance.*

**Carichi radiali**

**Radial loads**

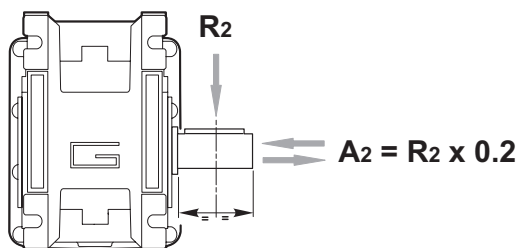

$n_2$ [min <sup>-1</sup> ]	$R_2$ [N]			
	CMB 402	CMB 502	CMB 633	CMB 903
400	905	1116	1835	2682
300	996	1228	2020	2952
200	1141	1406	2312	3379
170	1204	1484	2441	3567
140	1414	1743	2604	3806
100	1582	1949	2913	4686
90	1638	2019	3321	4853
60	2047	2490	3801	5556
40	2524	3029	4492	6614
30	2778	3334	5159	7540
20	3180	3816	5906	8631
15	3500	4200	6500	9500
10	3500	4200	6500	9500

Quando il carico radiale risultante non è applicato sulla mezza-  
ria dell'albero occorre calcolare quello effettivo con la seguente  
formula:

*When the resulting radial load is not applied on the centre line  
of the shaft it is necessary to calculate the effective load with the  
following formula:*

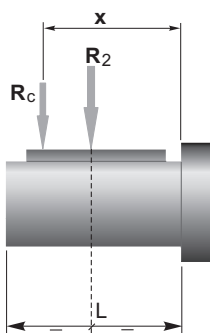

	CMB 402	CMB 502	CMB 633	CMB 903
a	86	104	118	157
b	66	79	93	117
$R_{2MAX}$	3500	4200	6500	9500

$$R_c = \frac{R_2 \cdot a}{(b + x)} \leq R_{2MAX}$$

$$R \leq R_c$$

*a, b = valori riportati nella tabella  
a, b = values given in the table*

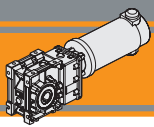

### Dati tecnici per servizio S2

### Technical data for S2 duty

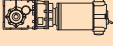
P <sub>1</sub> [W]	n <sub>2</sub> [min <sup>-1</sup> ]	M <sub>2</sub> [Nm]	sf	i		Versione motore Motor version
<b>100</b>						
(3000 min <sup>-1</sup> )	<b>485</b>	1.8	16.8	6.18	<b>070/402</b>	12E/24E
	<b>401</b>	2.2	13.8	7.49		120.66/240.66
	<b>326</b>	2.8	11.3	9.20		
	<b>254</b>	3.5	9.9	11.83		
	<b>240</b>	3.7	9.4	12.48		
	<b>202</b>	4.4	7.9	14.83		
	<b>170</b>	5.3	6.6	17.63		
	<b>161</b>	5.6	7.7	18.60		
	<b>134</b>	6.7	6.4	22.33		
	<b>125</b>	7.2	6.0	23.91		
	<b>104</b>	8.6	5.9	28.89		
	<b>97</b>	9.2	5.5	30.84		
	<b>89</b>	10	5.1	33.57		
	<b>84</b>	11	4.8	35.63		
	<b>70</b>	13	4.0	42.75		
	<b>54</b>	17	3.1	55.31		
	<b>51</b>	18	2.9	59.06		
	<b>47</b>	19	2.7	64.29		
	<b>41</b>	22	2.4	72.50		
	<b>54</b>	17	5.9	55.31		<b>070/502</b>
	<b>51</b>	18	5.5	59.06	120.66/240.66	
	<b>47</b>	19	5.1	64.29		
	<b>41</b>	22	4.5	72.50		
	<b>41</b>	22	8.8	73.96	<b>070/633</b>	12E/24E
	<b>38</b>	24	8.3	78.58		120.66/240.66
	<b>32</b>	28	7.0	93.33		
	<b>21</b>	42	4.6	140.52		
	<b>17</b>	54	3.6	181.81		
	<b>14</b>	63	3.1	211.31		
	<b>13</b>	71	2.7	238.31		

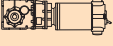
P <sub>1</sub> [W]	n <sub>2</sub> [min <sup>-1</sup> ]	M <sub>2</sub> [Nm]	sf	i		Versione motore Motor version
<b>140</b>						
(3000 min <sup>-1</sup> )	<b>41</b>	31	6.3	73.96	<b>100/633</b>	120/240/24E*
	<b>38</b>	33	5.9	78.58		120.66/240.66
	<b>32</b>	39	5.0	93.33		
	<b>21</b>	59	3.3	140.52		
	<b>17</b>	76	2.6	181.81		
	<b>14</b>	89	2.2	211.31		
	<b>13</b>	100	2.0	238.31		

P <sub>1</sub> [W]	n <sub>2</sub> [min <sup>-1</sup> ]	M <sub>2</sub> [Nm]	sf	i		Versione motore Motor version
<b>250</b>						
(3000 min <sup>-1</sup> )	<b>485</b>	4.6	6.7	6.18	<b>180/402</b>	120/240*
	<b>401</b>	5.6	5.5	7.49		24E
	<b>326</b>	6.9	4.5	9.20		120.66/240.66
	<b>254</b>	8.8	4.0	11.83		
	<b>240</b>	9.3	3.7	12.48		
	<b>202</b>	11	3.2	14.83		
	<b>170</b>	13	2.7	17.63		
	<b>161</b>	14	3.1	18.60		
	<b>134</b>	17	2.6	22.33		
	<b>125</b>	18	2.4	23.91		
	<b>104</b>	22	2.4	28.89		
	<b>97</b>	23	2.2	30.84		
	<b>89</b>	25	2.0	33.57		
	<b>84</b>	27	1.9	35.63		
	<b>70</b>	32	1.6	42.75		
	<b>54</b>	41	1.2	55.31		
	<b>51</b>	44	1.2	59.06		
	<b>47</b>	48	1.1	64.29		
	<b>41</b>	54	0.9	72.50		
	<b>134</b>	17	5.1	22.33		<b>180/502</b>
	<b>125</b>	18	4.8	23.91	24E	
	<b>104</b>	22	4.5	28.89	120.66/240.66	
	<b>97</b>	23	4.2	30.84		
	<b>89</b>	25	3.9	33.57		
	<b>84</b>	27	3.7	35.63		
	<b>70</b>	32	3.1	42.75		
	<b>54</b>	41	2.4	55.31		
	<b>51</b>	44	2.2	59.06		
	<b>47</b>	48	2.0	64.29		
	<b>41</b>	54	1.8	72.50		
	<b>52</b>	43	4.5	57.93	<b>180/633</b>	120/240*
	<b>49</b>	46	4.2	61.63		24E
	<b>41</b>	55	3.5	73.96		120.66/240.66
	<b>38</b>	59	3.3	78.58		
	<b>32</b>	70	2.8	93.33		
	<b>21</b>	105	1.9	140.52		
	<b>17</b>	136	1.4	181.81		
	<b>14</b>	158	1.2	211.31		
	<b>13</b>	178	1.1	238.31		

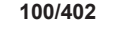
P <sub>1</sub> [W]	n <sub>2</sub> [min <sup>-1</sup> ]	M <sub>2</sub> [Nm]	sf	i		Versione motore Motor version
<b>140</b>						
(3000 min <sup>-1</sup> )	<b>485</b>	2.6	12.0	6.18	<b>100/402</b>	120/240/24E*
	<b>401</b>	3.1	9.9	7.49		120.66/240.66
	<b>326</b>	3.9	8.0	9.20		
	<b>254</b>	5.0	7.1	11.83		
	<b>240</b>	5.2	6.7	12.48		
	<b>202</b>	6.2	5.6	14.83		
	<b>170</b>	7.4	4.7	17.63		
	<b>161</b>	7.8	5.5	18.60		
	<b>134</b>	9.4	4.6	22.33		
	<b>125</b>	10	4.3	23.91		
	<b>104</b>	12	4.2	28.89		
	<b>97</b>	13	3.9	30.84		
	<b>89</b>	14	3.6	33.57		
	<b>84</b>	15	3.4	35.63		
	<b>70</b>	18	2.8	42.75		
	<b>54</b>	23	2.2	55.31		
	<b>51</b>	25	2.1	59.06		
	<b>47</b>	27	1.9	64.29		
	<b>41</b>	30	1.7	72.50		
	<b>54</b>	23	4.2	55.31		<b>100/502</b>
	<b>51</b>	25	4.0	59.06	120.66/240.66	
	<b>47</b>	27	3.6	64.29		
	<b>41</b>	30	3.2	72.50		

\*: Motore inclinato con portaspazzole a 45°  
Motor assembly with brush holder inclined 45°

**NOTA:** per servizio continuo o altamente intermittente, contattare il servizio tecnico

**NOTE:** for continuous or highly intermittent duty, please contact our technical service

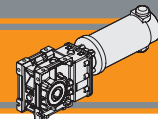

Dati tecnici per servizio S2

Technical data for S2 duty

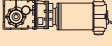
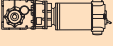
P <sub>1</sub> [W]	n <sub>2</sub> [min <sup>-1</sup> ]	M <sub>2</sub> [Nm]	sf	i		Versione motore Motor version	P <sub>1</sub> [W]	n <sub>2</sub> [min <sup>-1</sup> ]	M <sub>2</sub> [Nm]	sf	i		Versione motore Motor version	
<b>350</b>							<b>500</b>							
(3000 min <sup>-1</sup> )	<b>485</b>	6.5	4.8	6.18	<b>250/402</b>	120/240	(3000 min <sup>-1</sup> )	<b>485</b>	9	3.4	6.18	<b>350/402</b>	120/240	
	<b>401</b>	7.8	4	7.49		120.66/240.66		<b>401</b>	11	2.8	7.49		120.66/240.66	
	<b>326</b>	9.6	3.2	9.20	<b>250/502</b>	120/240 120.66/240.66		<b>326</b>	14	2.3	9.2	<b>350/502</b>	120/240 120.66/240.66	
	<b>254</b>	12	2.8	11.83										
	<b>240</b>	13	2.7	12.48										
	<b>202</b>	16	2.3	14.83										
	<b>170</b>	19	1.9	17.63										
	<b>161</b>	20	2.2	18.60										
	<b>134</b>	23	1.8	22.33										
	<b>125</b>	25	1.7	23.91										
	<b>104</b>	30	1.7	28.89										
	<b>97</b>	32	1.6	30.84										
	<b>89</b>	35	1.5	33.57										
	<b>84</b>	37	1.4	35.63										
	<b>70</b>	45	1.1	42.75										
	<b>54</b>	58	0.9	55.31										
	<b>51</b>	62	0.8	59.06										
	<b>47</b>	67	0.8	64.29										
	<b>41</b>	72	0.7	72.50										
	<b>485</b>	6.5	8.5	6.18	<b>250/633</b>	120/240 120.66/240.66		<b>326</b>	14	4.0	9.20	<b>350/633</b>	120/240 120.66/240.66	
	<b>401</b>	7.8	7.0	7.49				<b>254</b>	18	4.0	11.83			
	<b>326</b>	9.6	5.7	9.2										
	<b>254</b>	12	5.7	11.83										
	<b>240</b>	13	5.4	12.48										
	<b>202</b>	16	4.5	14.83										
	<b>170</b>	19	3.8	17.63										
	<b>161</b>	20	4.4	18.6										
	<b>134</b>	23	3.7	22.33										
	<b>125</b>	25	3.4	23.91										
	<b>104</b>	30	3.2	28.89										
	<b>97</b>	32	3.0	30.84										
	<b>89</b>	35	2.8	33.57										
	<b>84</b>	37	2.6	35.63										
	<b>70</b>	45	2.2	42.75										
	<b>54</b>	58	1.7	55.31										
	<b>51</b>	62	1.6	59.06										
	<b>47</b>	67	1.5	64.29										
	<b>41</b>	76	1.3	72.50										
	<b>106</b>	30	5.8	28.17		<b>139</b>	32	5.3	21.56		<b>113</b>	40	4.3	26.48
	<b>89</b>	35	4.9	33.81		<b>106</b>	42	4.1	28.17		<b>89</b>	51	3.4	33.81
	<b>84</b>	38	4.6	35.92		<b>89</b>	51	3.4	33.81		<b>84</b>	54	3.2	35.92
	<b>77</b>	41	4.8	38.88		<b>84</b>	54	3.2	35.92		<b>77</b>	58	3.4	38.88
	<b>64</b>	49	4.0	47.16		<b>77</b>	58	3.4	38.88		<b>64</b>	71	2.8	47.16
	<b>52</b>	61	3.2	57.93		<b>64</b>	71	2.8	47.16		<b>52</b>	87	2.2	57.93
	<b>49</b>	65	3.0	61.63		<b>49</b>	92	2.1	61.63		<b>41</b>	111	1.8	73.96
	<b>41</b>	78	2.5	73.96		<b>41</b>	111	1.8	73.96		<b>38</b>	118	1.7	78.58
	<b>38</b>	82	2.4	78.58		<b>38</b>	118	1.7	78.58		<b>32</b>	140	1.4	93.33
	<b>32</b>	98	2.0	93.33		<b>32</b>	140	1.4	93.33		<b>21</b>	210	0.9	140.52
	<b>21</b>	147	1.3	140.52		<b>21</b>	210	0.9	140.52		<b>17</b>	272	0.7	181.81
	<b>17</b>	190	1.0	181.81		<b>17</b>	272	0.7	181.81		<b>14</b>	279	0.7	211.31
	<b>14</b>	221	0.9	211.31		<b>14</b>	279	0.7	211.31					
	<b>13</b>	250	0.8	238.31										

ECMB

**NOTA:** per servizio continuo o altamente intermittente, contattare il servizio tecnico

**NOTE:** for continuous or highly intermittent duty, please contact our technical service

NOTA

Verificare sempre che la coppia M<sub>2</sub> utilizzata non ecceda il valore indicato nelle caselle in grigio

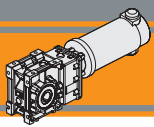

NOTE

Please check that the output torque M<sub>2</sub> does not exceed the value in the grey areas

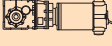
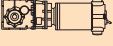

### Dati tecnici per servizio S2

### Technical data for S2 duty

P <sub>1</sub> [W]	n <sub>2</sub> [min <sup>-1</sup> ]	M <sub>2</sub> [Nm]	sf	i		Versione motore Motor version	P <sub>1</sub> [W]	n <sub>2</sub> [min <sup>-1</sup> ]	M <sub>2</sub> [Nm]	sf	i		Versione motore Motor version	
<b>800</b>							<b>800</b>							
(3000 min <sup>-1</sup> )	<b>485</b>	15	2.1	6.18	<b>600/402</b>	120/240	(3000 min <sup>-1</sup> )	<b>97</b>	74	1.3	30.84	<b>600/502</b>	120/240	
	<b>401</b>	18	1.7	7.49		120.66/240.66		<b>89</b>	80	1.2	33.57		120.66/240.66	
	<b>326</b>	22	1.4	9.20				<b>84</b>	85	1.1	35.63			
	<b>254</b>	28	1.2	11.83				<b>70</b>	102	1.0	42.75			
	<b>240</b>	30	1.2	12.48				<b>54</b>	132	0.7	55.31			
	<b>202</b>	36	1.0	14.83				<b>51</b>	140	0.7	59.06			
	<b>170</b>	42	0.8	17.63				<b>47</b>	140	0.7	64.29			
	<b>161</b>	45	1.0	18.60				<b>41</b>	140	0.7	72.50			
	<b>134</b>	53	0.8	22.33				<b>306</b>	23	5.0	9.81		<b>600/633</b>	120/240
	<b>125</b>	57	0.8	23.91				<b>287</b>	25	4.7	10.44			120.66/240.66
	<b>104</b>	69	0.7	28.89				<b>239</b>	30	3.9	12.53			
	<b>97</b>	73	0.7	30.84				<b>225</b>	32	3.7	13.31			
	<b>89</b>	73	0.7	33.57				<b>190</b>	38	3.5	15.81			
	<b>84</b>	73	0.7	35.63				<b>169</b>	43	4.0	17.77			
	<b>70</b>	73	0.7	42.75			<b>139</b>	52	3.3	21.56				
	<b>485</b>	15	3.7	6.18	<b>600/502</b>	120/240	<b>113</b>	63	2.7	26.48				
	<b>401</b>	18	3.1	7.49		120.66/240.66		<b>106</b>	67	2.6	28.17			
	<b>326</b>	22	2.5	9.20				<b>89</b>	81	2.1	33.81			
	<b>254</b>	28	2.5	11.83				<b>84</b>	86	2.0	35.92			
	<b>240</b>	30	2.3	12.48				<b>77</b>	93	2.1	38.88			
	<b>202</b>	36	2.0	14.83				<b>64</b>	113	1.7	47.16			
	<b>170</b>	42	1.7	17.63				<b>52</b>	139	1.4	57.93			
	<b>161</b>	45	1.9	18.60				<b>49</b>	148	1.3	61.63			
	<b>134</b>	53	1.6	22.33				<b>41</b>	177	1.1	73.96			
	<b>125</b>	57	1.5	23.91				<b>38</b>	188	1.0	78.58			
	<b>104</b>	69	1.4	28.89				<b>32</b>	223	0.9	93.33			
								<b>21</b>	279	0.7	140.52			
								<b>114</b>	63	5.6	26.30	<b>600/903</b>	120/240	
								<b>99</b>	72	4.8	30.25		IEC 71B5	
							<b>76</b>	94	4.1	39.26				
							<b>63</b>	113	3.4	47.25	+			
							<b>52</b>	138	2.8	57.52	Giunto FX			
							<b>45</b>	158	2.5	66.17	FX Coupling			
							<b>36</b>	199	2.0	83.20	Solo / Only			
							<b>28</b>	259	1.5	108.09				
							<b>23</b>	317	1.2	132.23				
							<b>20</b>	354	1.1	147.92				
							<b>18</b>	400	1.0	167.09				
							<b>16</b>	457	0.9	191.06				
							<b>14</b>	531	0.7	221.88				
							<b>11</b>	557	0.7	262.96				

NOTA  
Verificare sempre che la coppia M<sub>2</sub> utilizzata non ecceda il valore indicato nelle caselle in grigio  
NOTE  
Please check that the output torque M<sub>2</sub> does not exceed the value in the grey areas

**NOTA:** per servizio continuo o altamente intermittente, contattare il servizio tecnico  
**NOTE:** for continuous or highly intermittent duty, please contact our technical service



### Motori applicabili

### Motor adapters

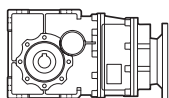
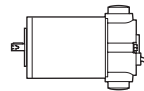

		EC					
		070.12E 070.24E	100.120 100.240 100.24E	180.120 180.240 180.24E	250.120 250.240	350.120 350.240	600.120 600.240
<b>CMB</b>	<b>402</b>	6.18 - 72.50	6.18 - 72.50 *			6.18 - 72.50	
	<b>502</b>	6.18 - 72.50	6.18 - 72.50 *			6.18 - 72.50	
	<b>633</b>	6.58 - 238.31	6.58 - 238.31 *			6.58 - 238.31	
	<b>933</b>				**	6.65 - 262.96 (!)	

6.18 - 72.50

Rapporti di riduzione i  
Ratio i

(!): Solo IEC 71B5 con giunto FX  
71 B5 only with FX coupling

\*: Motore inclinato con portaspazzole a 45°  
Motor assembly with brush holder inclined 45°

\*\*.: Contattare il servizio tecnico  
Please contact our technical service

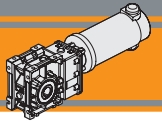

Dimensioni

Dimensions

ECMB070/402 U

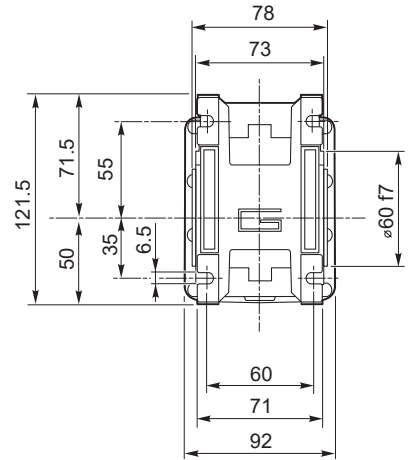
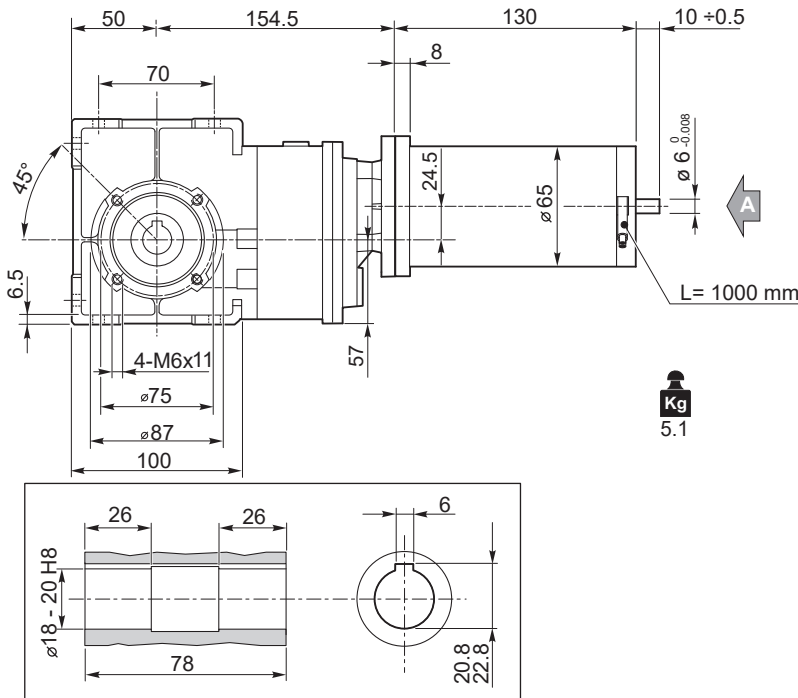

**Kg**  
5.1

ECMB070/502 U

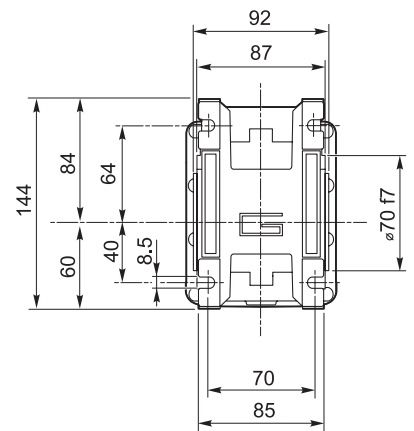
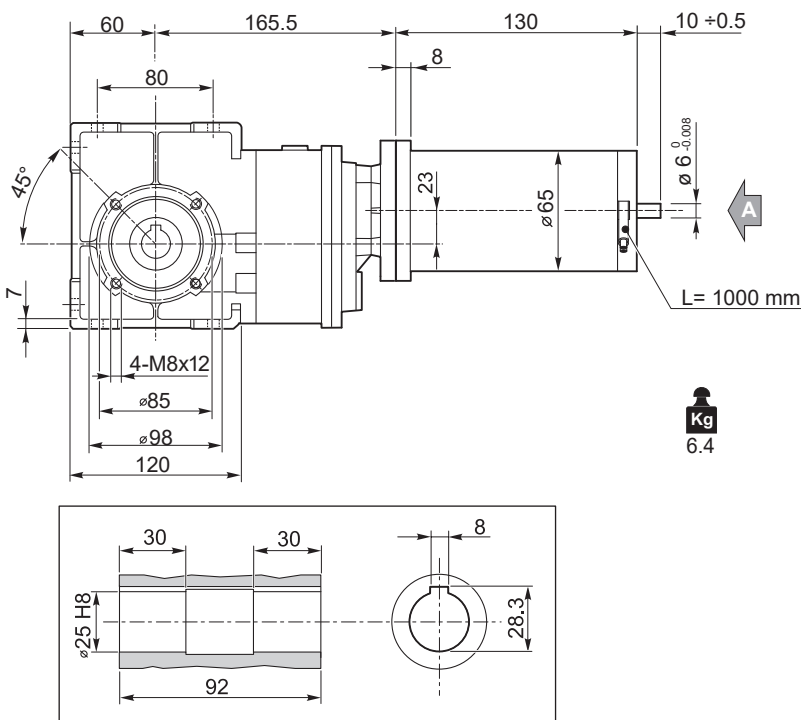

**Kg**  
6.4

ECMB

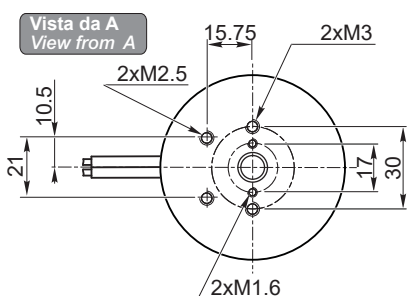

Freno / Brake → I23

Encoder → I24

Motori / Motors IP66 → L2

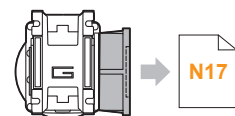



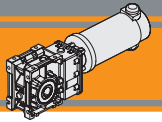

Dimensioni

Dimensions

ECMB100/502 U

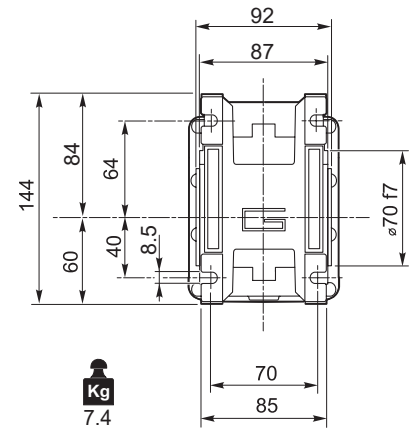
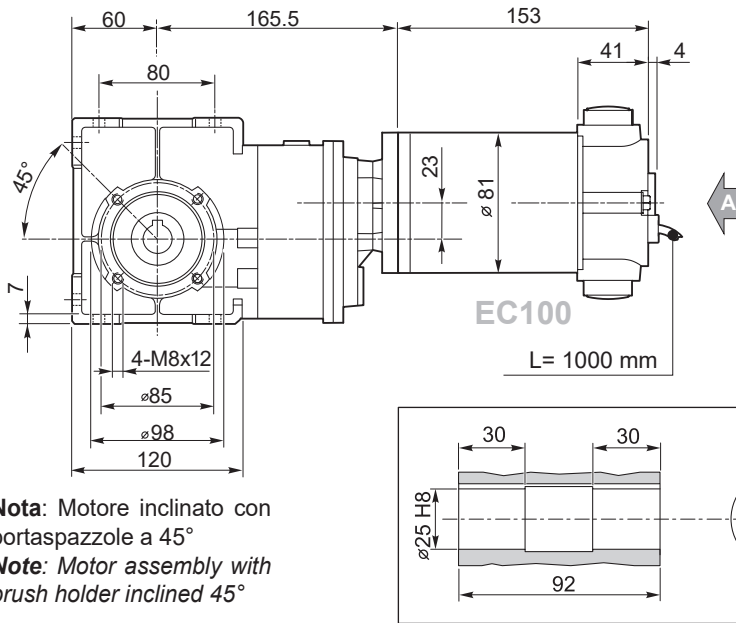

**Nota:** Motore inclinato con portaspazzole a 45°  
**Note:** Motor assembly with brush holder inclined 45°

ECMB100/633 U

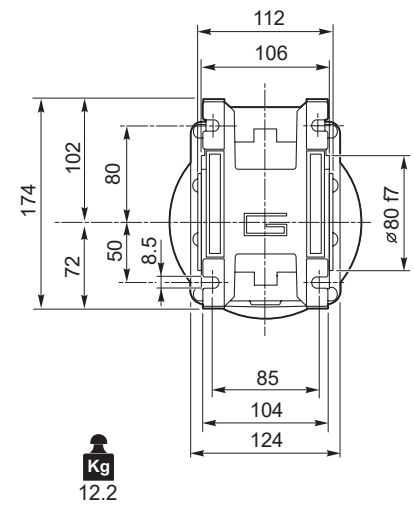
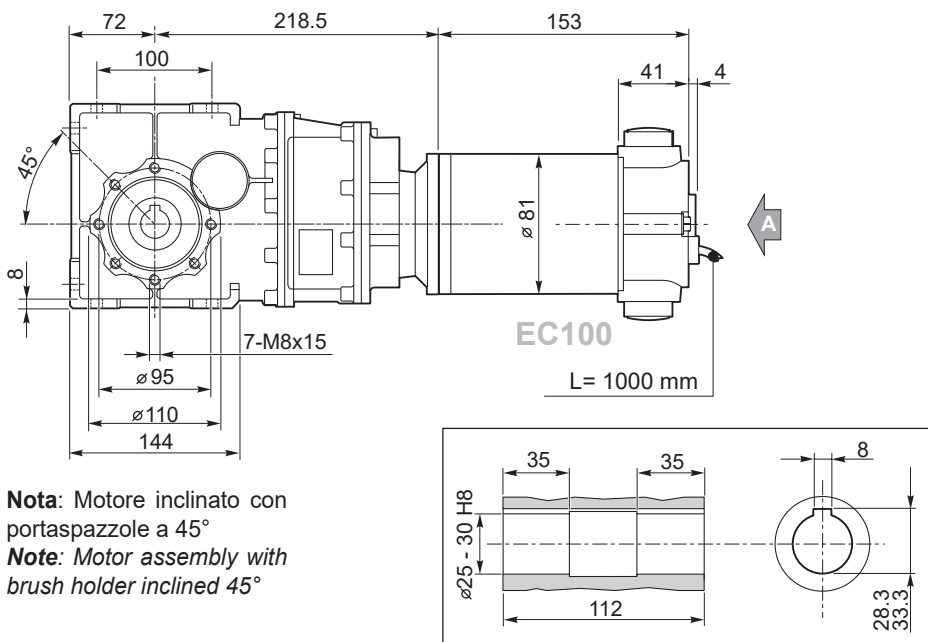

**Nota:** Motore inclinato con portaspazzole a 45°  
**Note:** Motor assembly with brush holder inclined 45°

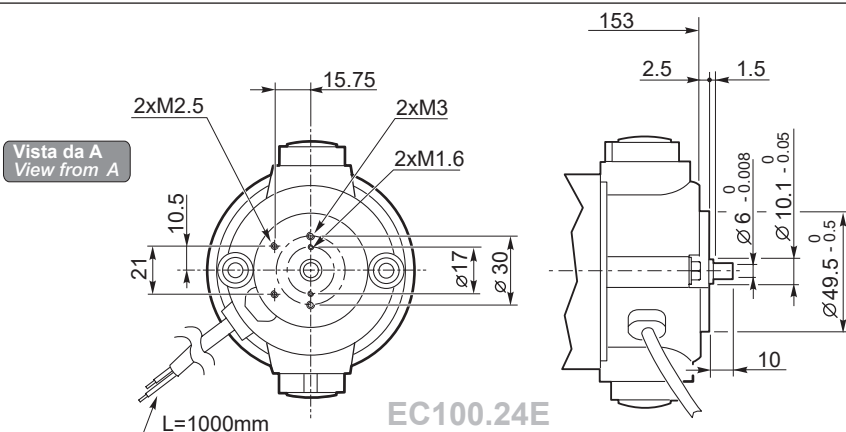

**Nota:** Motore inclinato con portaspazzole a 45°  
**Note:** Motor assembly with brush holder inclined 45°

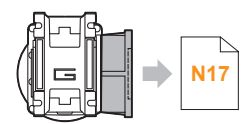

ECMB

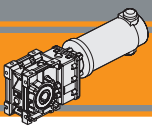

**Dimensioni**

**Dimensions**

**ECMB180/402 U**

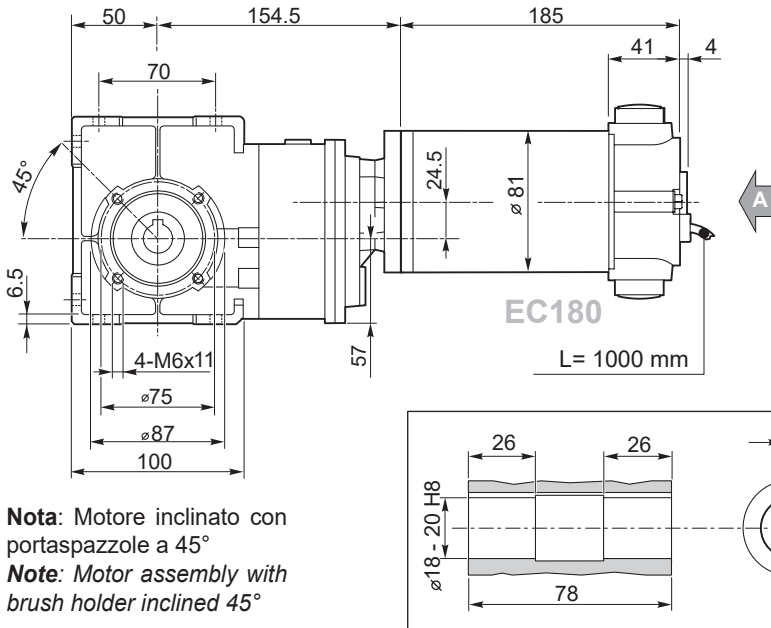

**Nota:** Motore inclinato con portaspazzole a 45°  
**Note:** Motor assembly with brush holder inclined 45°

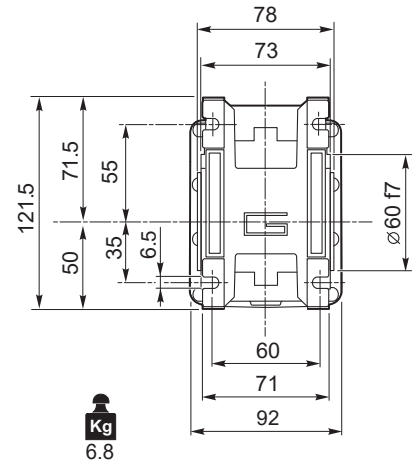

**ECMB180/502 U**

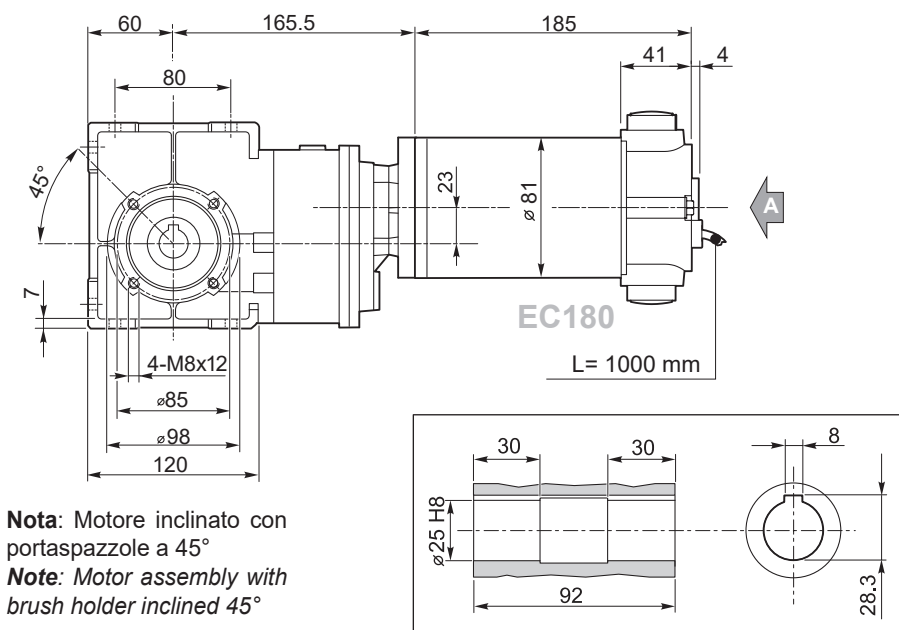

**Nota:** Motore inclinato con portaspazzole a 45°  
**Note:** Motor assembly with brush holder inclined 45°

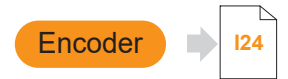
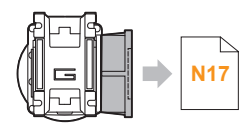
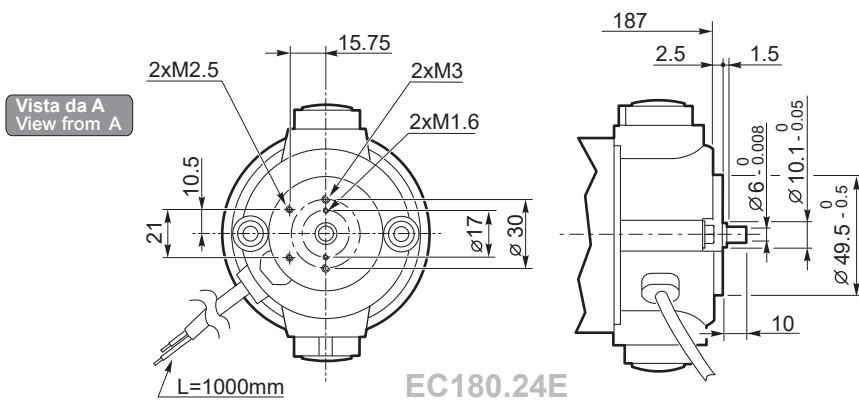
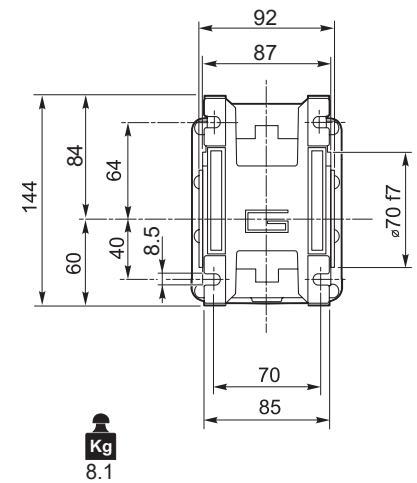

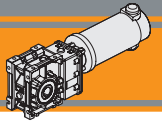

Dimensioni

Dimensions

ECMB180/633 U

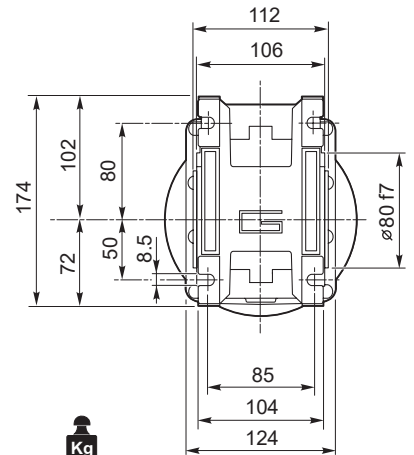
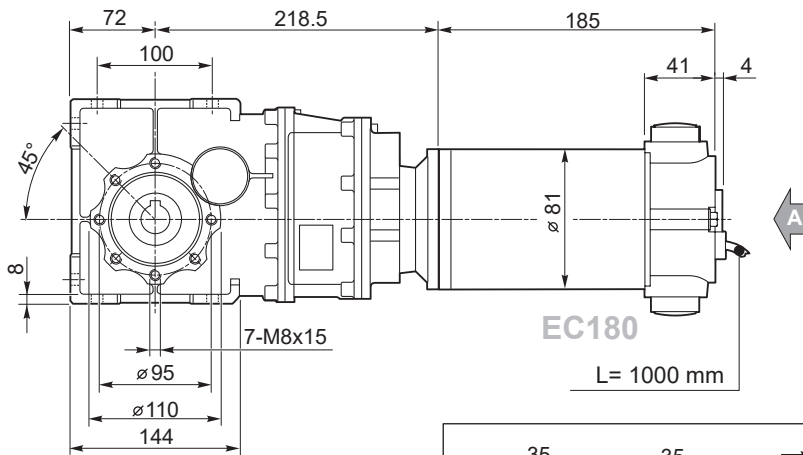

**Kg**  
11.9

**Nota:** Motore inclinato con portaspazzole a 45°

**Note:** Motor assembly with brush holder inclined 45°

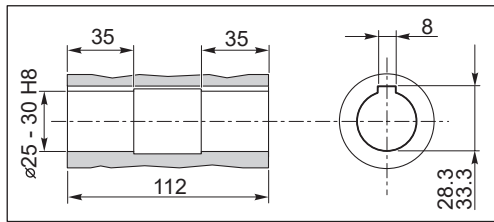

Vista da A  
View from A

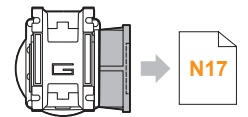
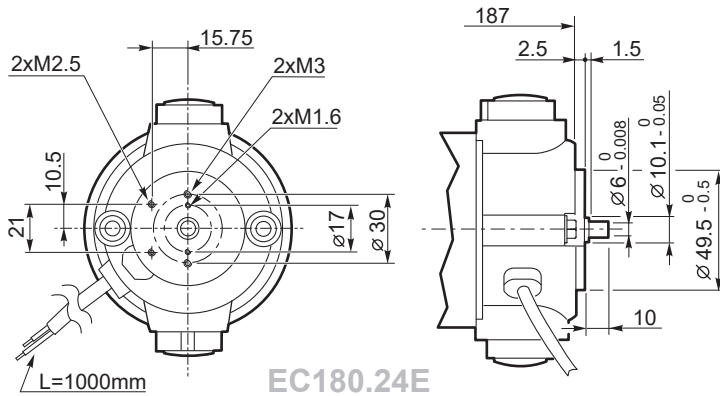

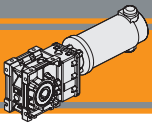

### Dimensioni

### Dimensions

#### ECMB250/402 U

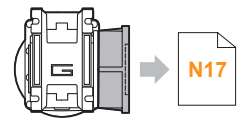
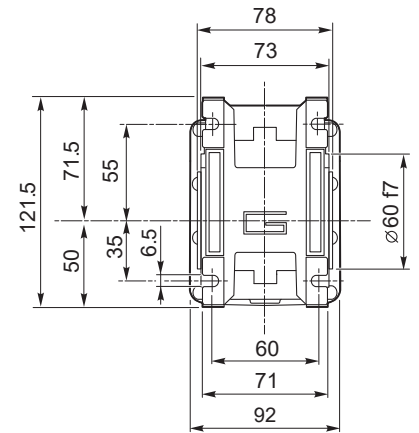
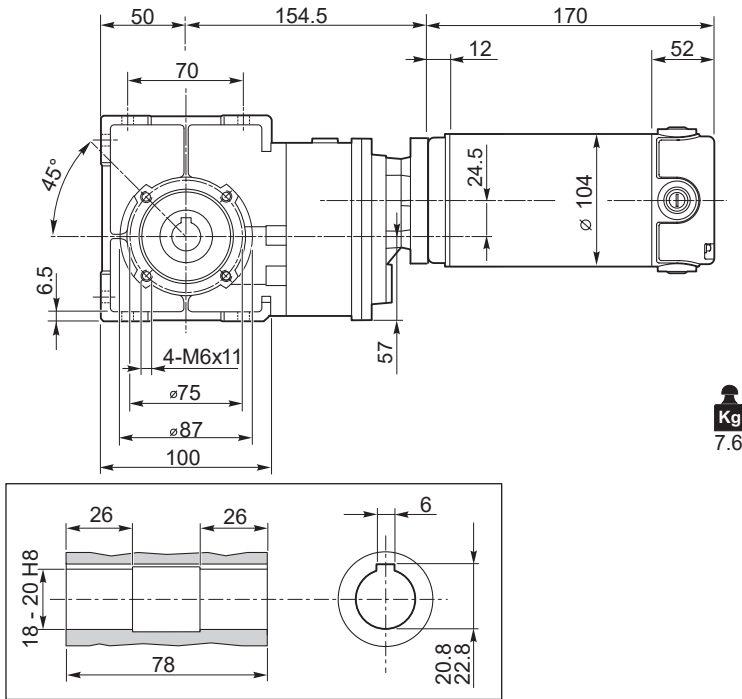

#### ECMB250/502 U

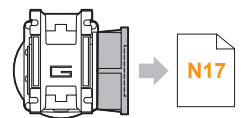
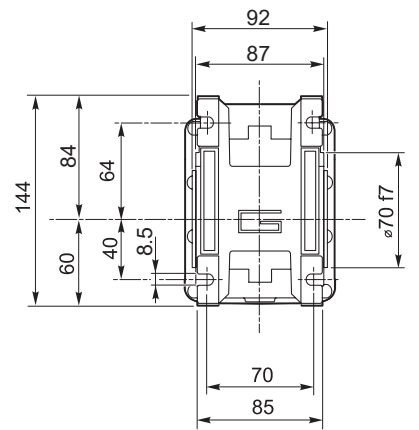
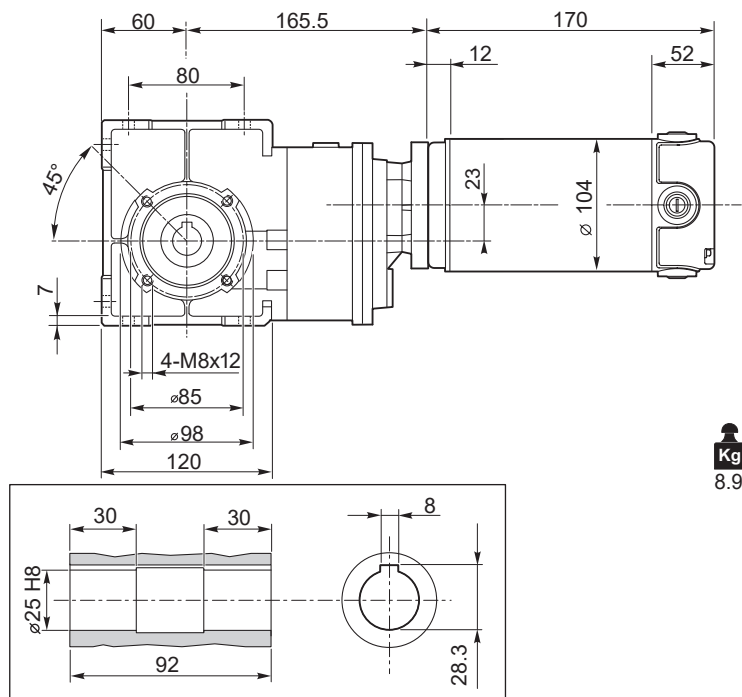

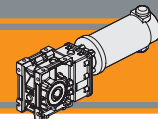

Dimensioni

Dimensions

ECMB250/633 U

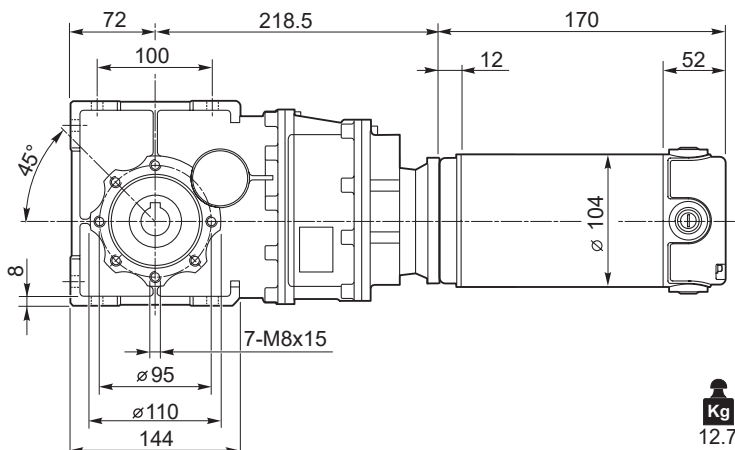

**Kg**  
12.7

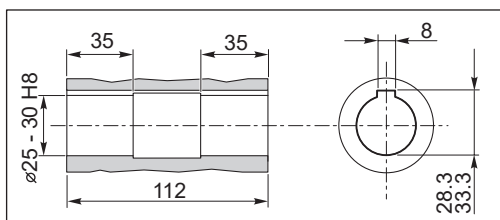
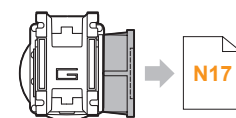
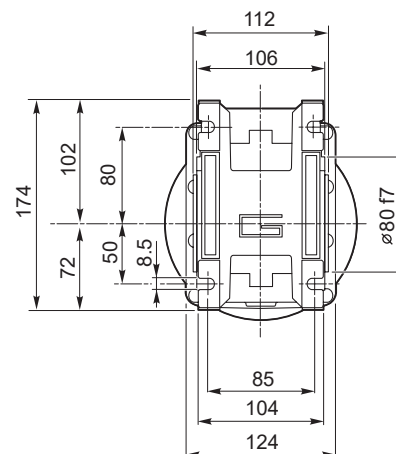

ECMB350/402 U

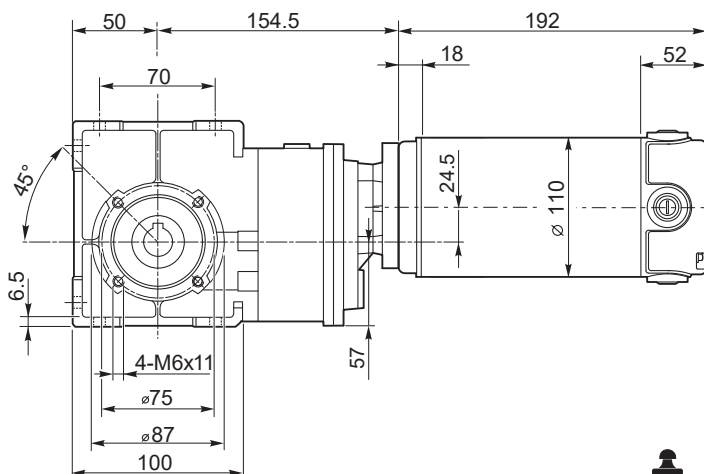

**Kg**  
8.7

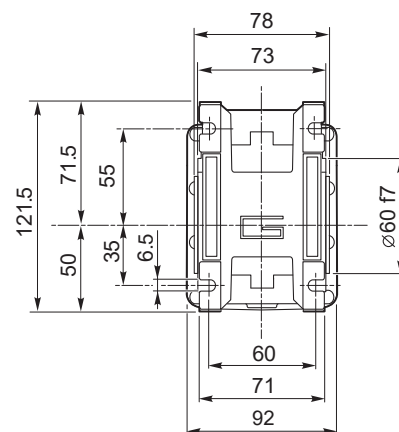

ECMB

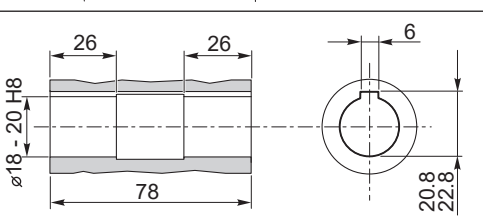
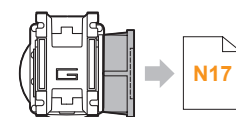

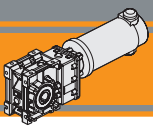

### Dimensioni

### Dimensions

#### ECMB350/502 U

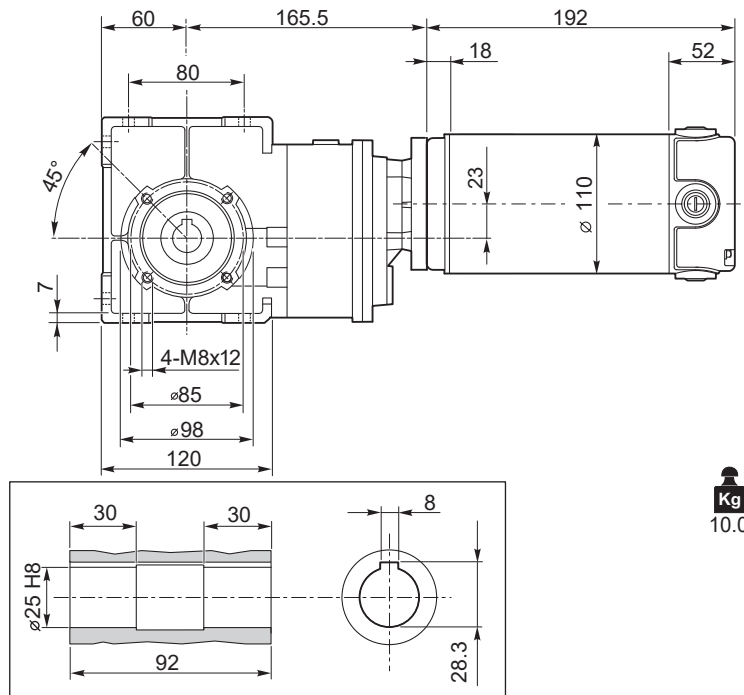

**Kg**  
10.0

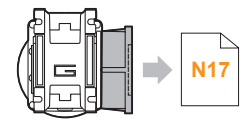
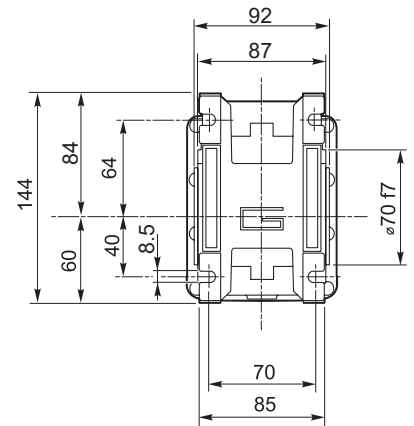

#### ECMB350/633 U

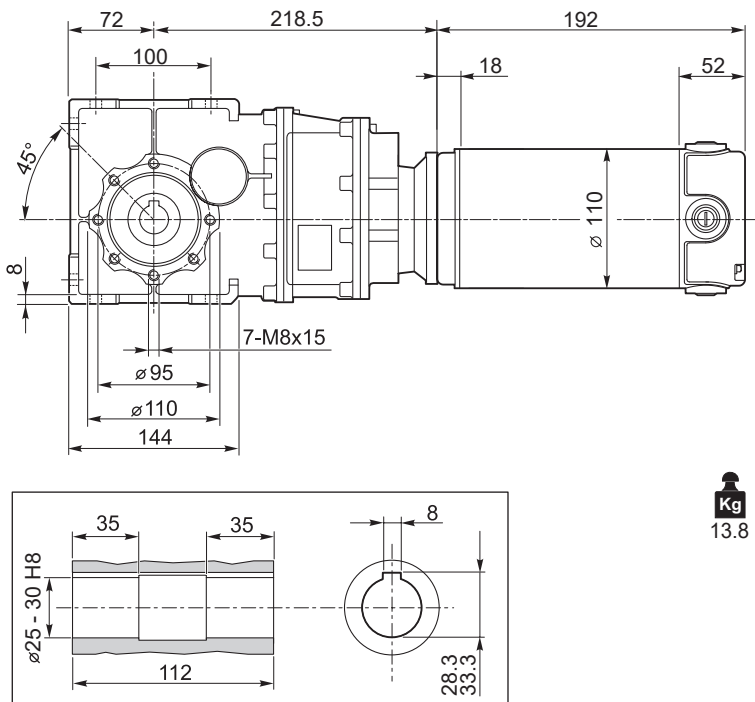

**Kg**  
13.8

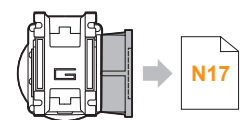
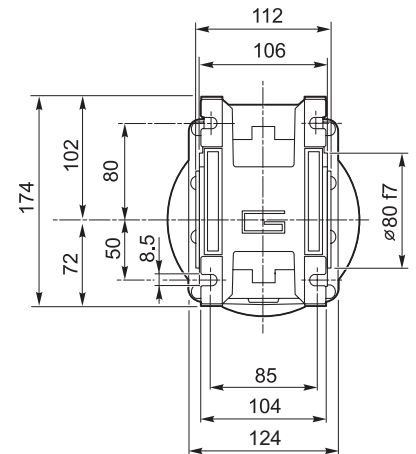

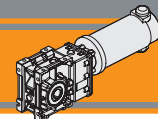

Dimensioni

Dimensions

ECMB600/402 U

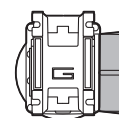
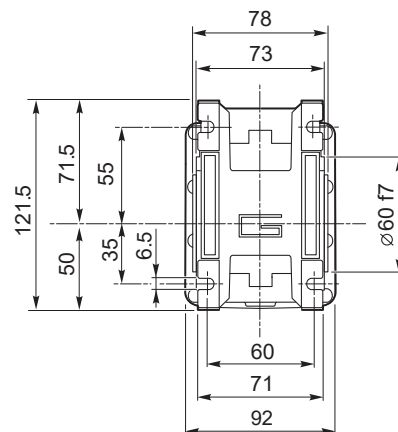
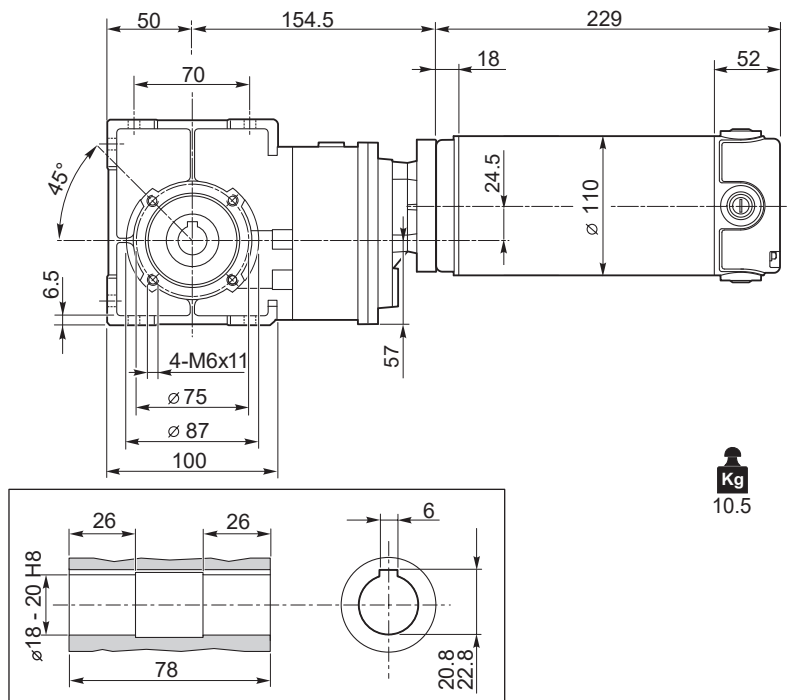

N17

Freno / Brake

I23

Motori / Motors IP66

L12

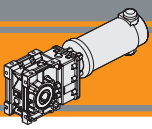

### Dimensioni

### Dimensions

#### ECMB600/502 U

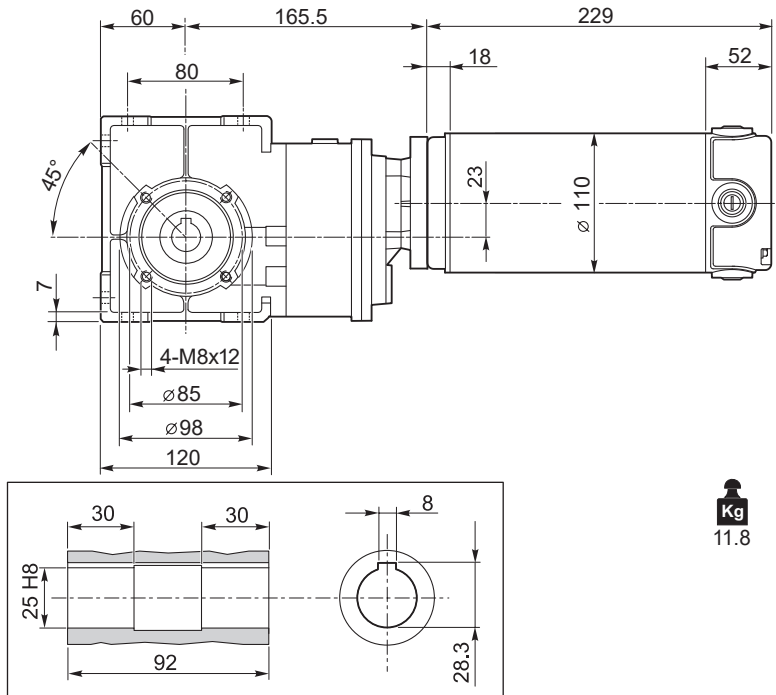

**Kg**  
11.8

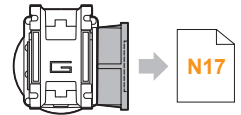
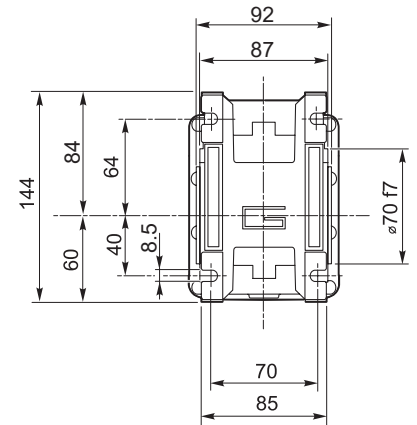

N17

Freno / Brake

I23

Motori / Motors IP66

L12

#### ECMB600/633 U

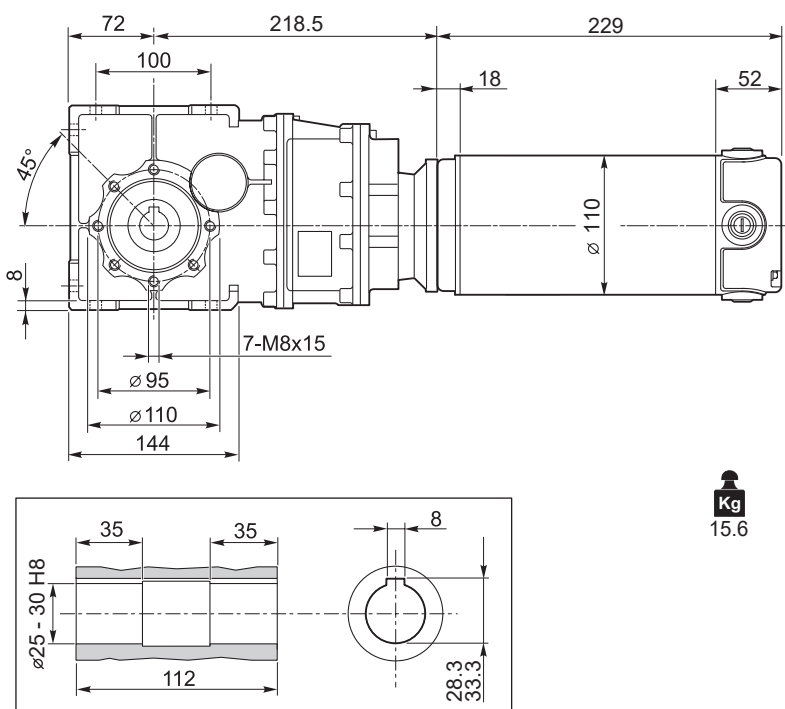

**Kg**  
15.6

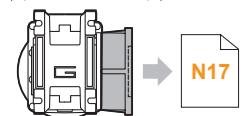
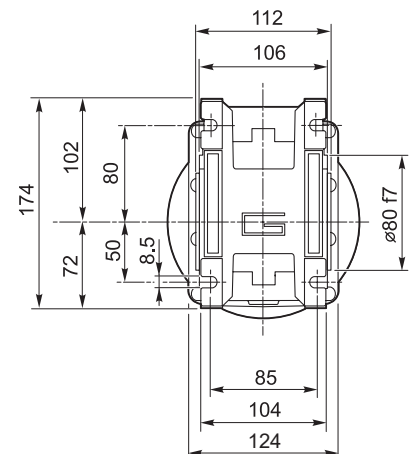

N17

Freno / Brake

I23

Motori / Motors IP66

L12

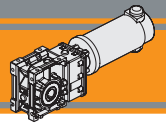

Dimensioni

Dimensions

ECMB600/903 U

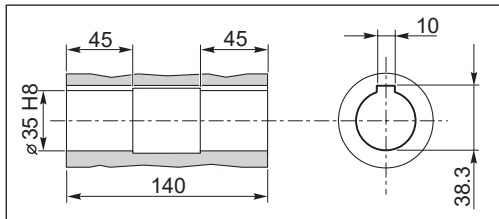
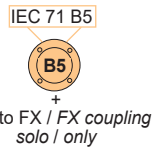
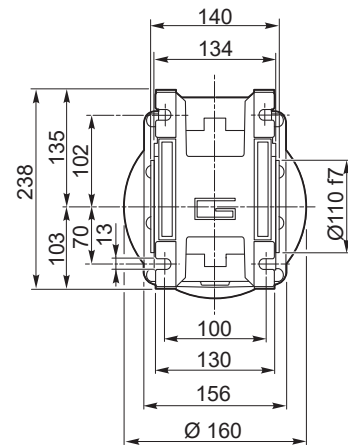
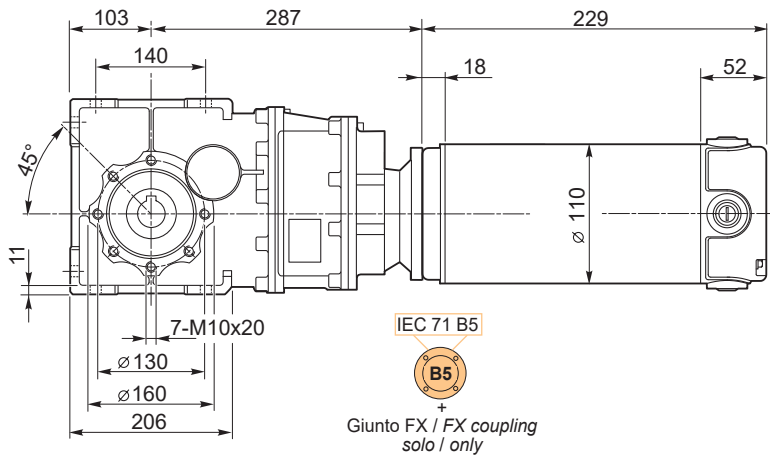

**Kg**  
25.5

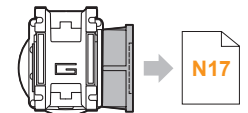

**Freno / Brake** → I23

ECMB.../... F... Flange uscita / Output flanges

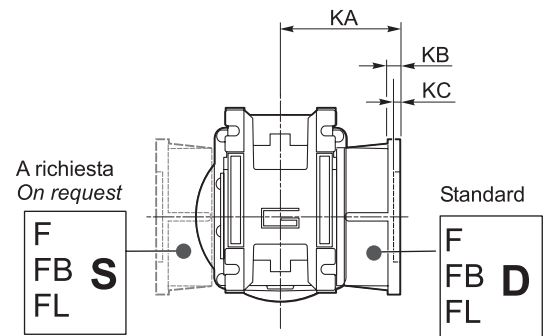
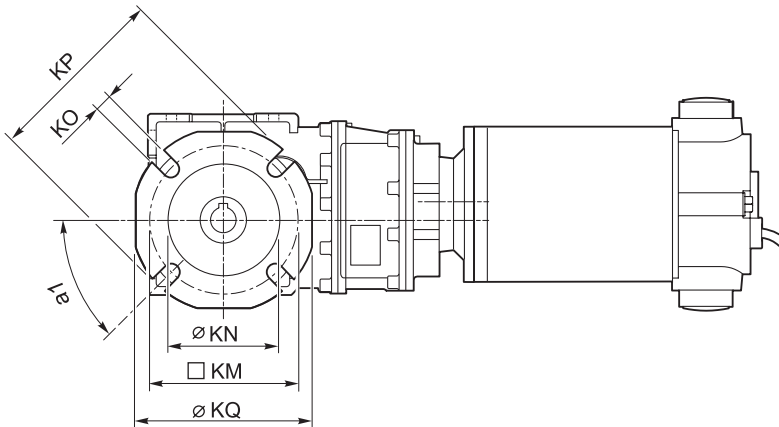

ECMB

CMB	Flange uscita / Output flanges																										
	F									FL									FB								
	a <sub>1</sub>	KA	KB	KC	KM	KN H8	KO	KP	KQ	a <sub>1</sub>	KA	KB	KC	KM	KN H8	KO	KP	KQ	a <sub>1</sub>	KA	KB	KC	KM	KN H8	KO	KP	KQ
402	45°	67	7.5	4.5	80-95	60	9	110	95	45°	97	7.5	4.5	80-95	60	9	110	95	45°	80	8.5	5	115-125	95	9.5	140	112
502	45°	90	9	5	90-110	70	11	125	110	45°	120	9	5	90-110	70	11	125	110	45°	89	9	5	130-145	110	9.5	160	132
633	45°	82	10	6	150 - 160	115	11	180	142	45°	112	10	8	150 - 160	115	11	180	142	45°	98	11	5	165	130	11	200	160
933	45°	111	13	6	175-188	152	14	210	200	-									-								

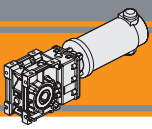

### Accessori

### Accessories

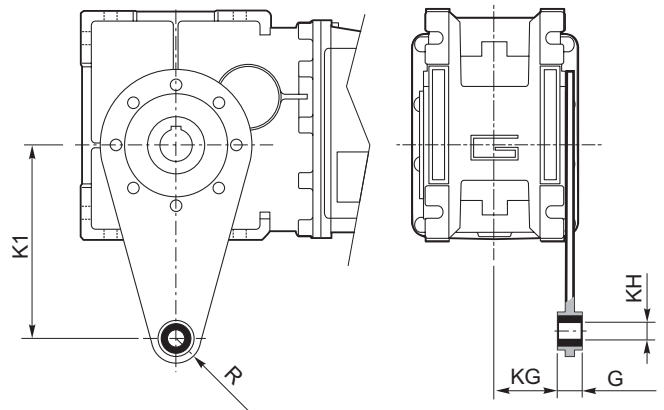
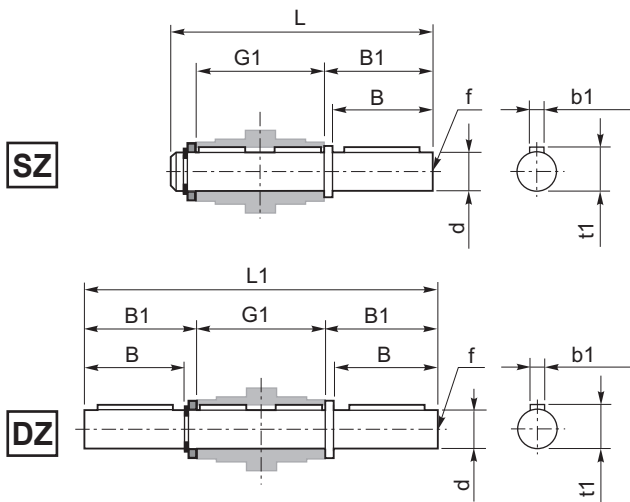

Albero lento / Output shaft

CMB CMBIS	d h7	B	B1	G1	L	L1	f	b1	t1
402	18	40	43	78	128	164	M6	6	20.5
502	25	50	53.5	92	153	199	M10	8	28
633	25	50	53.5	112	173	219	M10	8	28
903	35	80	84.5	140	234	309	M12	10	38

Braccio di reazione / Torque arm

CMB CMBIS	K1	G	KG	KH	R
402	100	14	31	10	18
502	100	14	38	10	18
633	150	14	47.5	10	18
903	200	25	56.5	20	30

### SC - Safety cover

### WD - Washdown cover

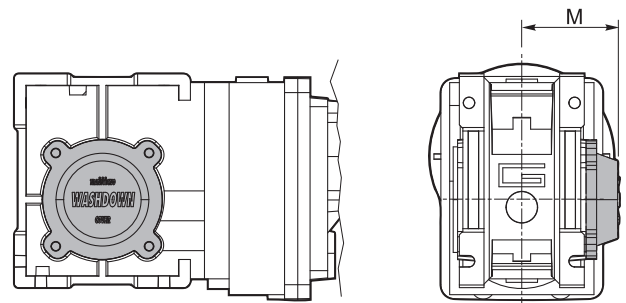
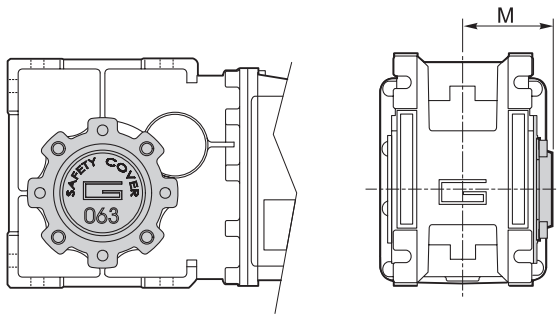

CMB CMBIS	M
402	54.5
502	62.5
633	73
903	94

CMB CMBIS	M
402	55.5
502	63.5
633	71.5
903	95



Ferrite

Motoriduttori CC pendolari  
**DC helical parallel gearmotors**





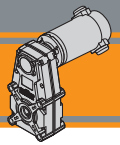

<b>Indice</b>	<b>Index</b>	Pag. Page
Caratteristiche tecniche	<i>Technical features</i>	<b>02</b>
Designazione	<i>Classification</i>	<b>02</b>
Sensi di rotazione	<i>Direction of rotation</i>	<b>03</b>
Simbologia	<i>Symbols</i>	<b>03</b>
Lubrificazione	<i>Lubrication</i>	<b>03</b>
Carichi radiali	<i>Radial loads</i>	<b>04</b>
Dati tecnici	<i>Technical data</i>	<b>05</b>
Motori applicabili	<i>Motor adapters</i>	<b>07</b>
Dimensioni	<i>Dimensions</i>	<b>08</b>

Questa sezione annulla e sostituisce ogni precedente edizione o revisione. Qualora questa sezione non Vi sia giunta in distribuzione controllata, l'aggiornamento dei dati ivi contenuto non è assicurato. **In tal caso la versione più aggiornata è disponibile sul nostro sito internet [www.transtecno.com](http://www.transtecno.com)**

*This section replaces any previous edition and revision. If you obtained this catalogue other than through controlled distribution channels, the most up to date content is not guaranteed. In this case the latest version is available on our web site [www.transtecno.com](http://www.transtecno.com)*

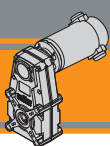

## Caratteristiche tecniche

## Technical features

I motoriduttori CC pendolari a magneti permanenti in ferrite ECFT hanno le seguenti caratteristiche principali:

ECFT ferrite permanent magnets DC helical parallel gearmotors range has the following main features:

- Alimentazione in bassa tensione 12/24 Vcc
- Possibilità di montaggio encoder e freno
- Potenze motore disponibili da 100 a 800W S2
- Magneti in ferrite
- Carcasa pressofusione di alluminio
- Lubrificazione permanente con olio sintetico.
- Ingranaggi cilindrici a denti elicoidali.

- Low voltage power supply 12/24 Vdc
- Suitable for encoder and brake assembly
- Motor power ratings available from 100 to 800W S2
- Ferrite magnets
- Die-cast aluminum housings
- Permanent synthetic oil long-life lubrication.
- helical gears.

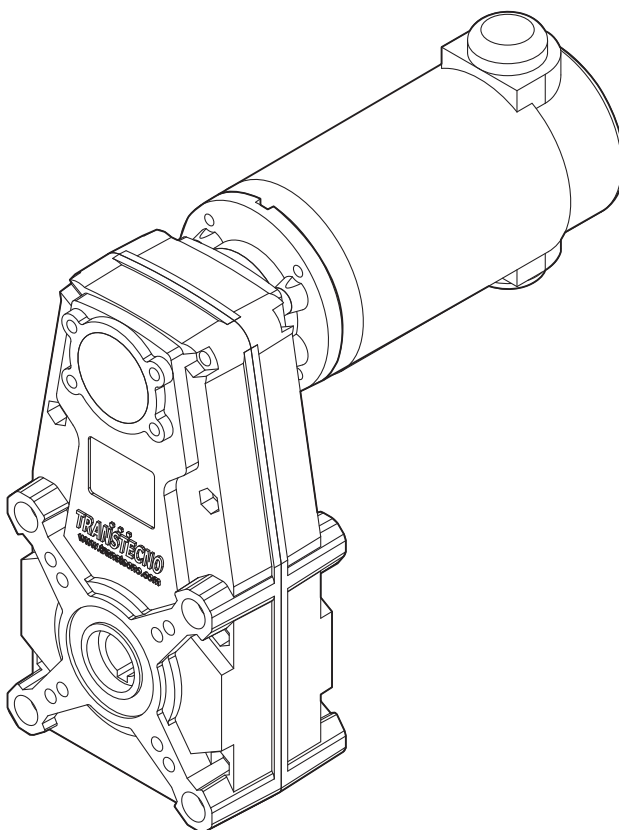

## Designazione

## Classification

MOTORIDUTTORE / GEARMOTORS							U	60.63	O20	240
ECFT	180/146						U	60.63	O20	240
Tipo Type	Grandezza Size						Versione Version	Rapporto Ratio	Albero cavo uscita Hollow output shaft	Versione motore Motor version
	070/105/3	100/105/3	180/105/3	250/146	350/146	600/146	U...	vedi tabelle see tables	vedi tabelle see tables	120 240 12E 24E
	070/105/4	100/146	180/146	250/176	350/176	600/176				
	070/146		180/176	250/196	350/196	600/196				
			180/196							

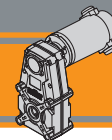

Sensi di rotazione

Direction of rotation

FT105/3  
FT146  
FT176  
FT196

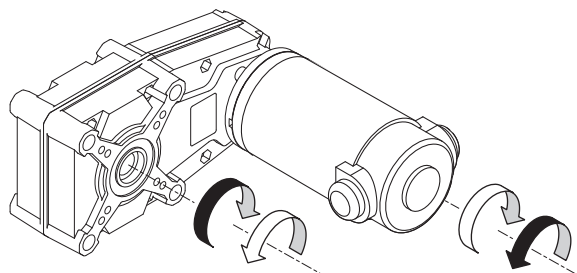
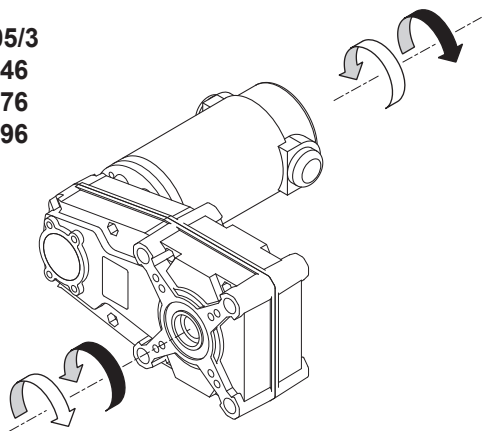

FT105/4

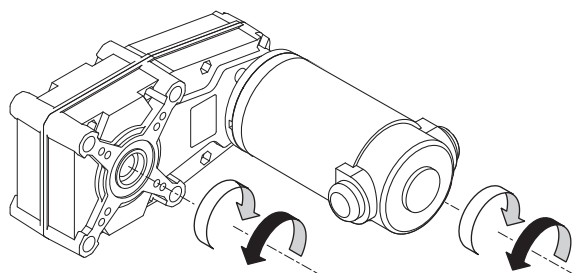
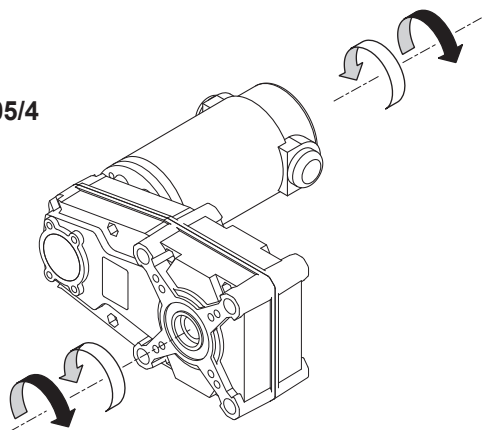

Simbologia

Symbols

$n_1$	[ $\text{min}^{-1}$ ]	Velocità in ingresso / <i>Input speed</i>
$n_2$	[ $\text{min}^{-1}$ ]	Velocità in uscita / <i>Output speed</i>
$i$		Rapporto di riduzione / <i>Ratio</i>
$P_1$	[kW]	Potenza in entrata / <i>Input power</i>
$M_2$	[Nm]	Coppia nominale in uscita in funzione di $P_1$ / <i>Output torque referred to <math>P_1</math></i>
$P_{n1}$	[kW]	Potenza nominale in entrata / <i>Nominal input power</i>
$M_{n2}$	[Nm]	Coppia nominale in uscita in funzione di $P_{n1}$ / <i>Nominal output torque referred to <math>P_{n1}</math></i>
$sf$		Fattore di servizio / <i>Service factor</i>
$R_2$	[N]	Carico radiale ammissibile in uscita / <i>Permitted output radial load</i>
$A_2$	[N]	Carico assiale ammissibile in uscita / <i>Permitted output axial load</i>

Lubrificazione

Lubrication

Tutti i motoriduttori sono forniti completi di lubrificante sintetico viscosità 320, pertanto possono essere installati in qualunque posizione di montaggio e non necessitano di manutenzione.

*Permanent synthetic oil long-life lubrication ( viscosity grade 320) makes it possible to use the gearmotors in all mounting positions; for this reason they can be installed in any assembly position and do not require maintenance.*

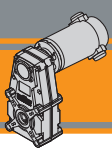

**Carichi radiali**

**Radial loads**

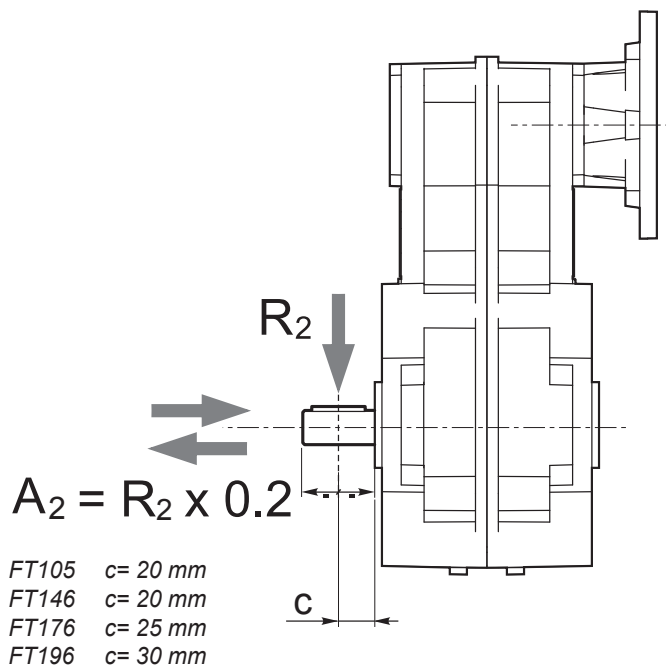

n <sub>2</sub> [min <sup>-1</sup> ]	R <sub>2</sub> [N]			
	FT105	FT146	FT176	FT196
200	800	1400	2000	2200
170	900	1600	2200	2400
140	1000	1800	2400	2600
120	1100	2000	2600	2800
100	1300	2200	2800	3100
70	1500	2500	3000	3500
50	1600	2600	3250	3750
40	1700	2700	3500	4000
30	1850	2850	4000	4600
20	2000	3000	4500	5500
10	2000	3000	5000	7000
5	2000	3000	5000	7000

Quando il carico radiale risultante non è applicato sulla mezzera dell'albero occorre calcolare quello effettivo con la seguente formula:

When the resulting radial load is not applied on the centre line of the shaft it is necessary to calculate the effective load with the following formula:

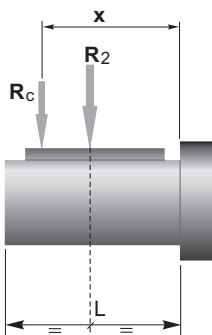

	FT105	FT146	FT176	FT196
<b>a</b>	82	82,5	115	132
<b>b</b>	62	62,5	90	102
<b>R<sub>2MAX</sub></b>	2000	3000	5000	7000

$$R_c = \frac{R_2 \cdot a}{(b + x)} \leq R_{2MAX}$$

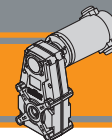

$$R \leq R_c$$

a, b = valori riportati nella tabella  
a, b = values given in the table



Dati tecnici

Technical data

P <sub>1</sub> [W]	n <sub>2</sub> [min <sup>-1</sup> ]	M <sub>2</sub> [Nm]	sf	i		Versione motore Motor version	P <sub>1</sub> [W]	n <sub>2</sub> [min <sup>-1</sup> ]	M <sub>2</sub> [Nm]	sf	i		Versione motore Motor version
<b>100</b>							<b>140</b>						
(3000 min <sup>-1</sup> )	<b>146</b>	6	5.1	20.57	<b>070/105/3</b>	12E/24E	(3000 min <sup>-1</sup> )	<b>41</b>	31	2.8	74.02	<b>100/146</b>	120/240/24E*
	<b>90</b>	10	3.9	33.32		120.66/240.66		<b>35</b>	35	2.4	84.63		120.66/240.66
	<b>68</b>	13	3.8	44.36				<b>31</b>	40	2.1	95.61		
	<b>55</b>	16	3.1	54.87				<b>26</b>	48	1.8	113.40		
	<b>42</b>	21	2.4	71.84				<b>22</b>	56	1.5	133.45		
	<b>39</b>	23	2.2	77.07				<b>20</b>	63	1.4	150.18		
	<b>34</b>	27	1.9	88.87				<b>19</b>	67	1.4	160.43		
	<b>24</b>	37	1.4	124.81				<b>17</b>	75	1.2	178.83		
	<b>17</b>	54	0.9	181.35				<b>15</b>	82	1.1	195.85		
	<b>13</b>	67	0.8	224.32				<b>13</b>	94	1.0	223.92		
	<b>9.5</b>	86	0.6	315.05			<b>13</b>	99	0.9	236.83			
							<b>10</b>	126	0.7	300.07			
	<b>8.1</b>	86	0.6	368.19	<b>070/105/4</b>	12E/24E	<b>250</b>						
	<b>5.6</b>	86	0.6	534.98		120.66/240.66	(3000 min <sup>-1</sup> )	<b>146</b>	15	2.0	20.57	<b>180/105/3</b>	120/240
	<b>4.5</b>	86	0.6	661.76				<b>90</b>	25	1.6	33.32		120.66/240.66
	<b>3.2</b>	86	0.6	929.40				<b>68</b>	33	1.5	44.36		
	<b>160</b>	6	11.1	18.75	<b>070/146</b>	12E/24E		<b>55</b>	41	1.2	54.87		
	<b>131</b>	7	9.1	22.89		120.66/240.66		<b>42</b>	54	0.9	71.84		
	<b>115</b>	8	8.0	26.17				<b>39</b>	58	0.9	77.07		
	<b>106</b>	8	7.4	28.26				<b>34</b>	66	0.8	88.87		
	<b>86</b>	10	7.4	35.07				<b>160</b>	14	4.4	18.75	<b>180/146</b>	120/240/24E*
	<b>76</b>	12	6.6	39.44				<b>131</b>	17	3.6	22.89		120.66/240.66
	<b>65</b>	14	5.6	46.44				<b>115</b>	20	3.2	26.17		
	<b>57</b>	16	4.9	52.86				<b>106</b>	21	3.0	28.26		
	<b>49</b>	18	4.7	60.63				<b>86</b>	26	3.0	35.07		
	<b>43</b>	21	4.1	70.00				<b>76</b>	30	2.6	39.44		
	<b>41</b>	22	3.9	74.02				<b>65</b>	35	2.2	46.44		
	<b>35</b>	25	3.4	84.63				<b>57</b>	40	2.0	52.86		
	<b>31</b>	29	3.0	95.61				<b>49</b>	45	1.9	60.63		
	<b>26</b>	34	2.5	113.40				<b>43</b>	52	1.6	70.00		
	<b>22</b>	40	2.1	133.45				<b>41</b>	55	1.5	74.02		
	<b>20</b>	45	1.9	150.18				<b>35</b>	63	1.4	84.63		
	<b>19</b>	48	1.9	160.43			<b>31</b>	72	1.2	95.61			
	<b>17</b>	54	1.7	178.83			<b>26</b>	85	1.0	113.40			
	<b>15</b>	59	1.6	195.85			<b>22</b>	100	0.9	133.45			
	<b>13</b>	67	1.4	223.92			<b>20</b>	112	0.8	150.18			
	<b>13</b>	71	1.3	236.83			<b>19</b>	120	0.8	160.43			
	<b>10</b>	90	1.0	300.07			<b>17</b>	134	0.7	178.83			
	<b>7.5</b>	119	0.8	397.38									
<b>140</b>							<b>140</b>						
(3000 min <sup>-1</sup> )	<b>146</b>	9	3.6	20.57	<b>100/105/3</b>	120/240/24E	*: Motore inclinato con portaspazzole a 45° Motor assembly with brush holder inclined 45°						
	<b>90</b>	14	2.8	33.32		120.66/240.66		NOTA Verificare sempre che la coppia M2 utilizzata non ecceda il valore indicato nelle caselle in grigio					
	<b>68</b>	19	2.7	44.36				NOTE Please check that the output torque M2 does not exceed the value in the grey areas					
	<b>55</b>	23	2.2	54.87				<b>NOTA:</b> per servizio continuo o altamente intermittente, contattare il servizio tecnico					
	<b>42</b>	30	1.7	71.84				<b>NOTE:</b> for continuous or highly intermittent duty, please contact our technical service					
	<b>39</b>	32	1.6	77.07									
	<b>34</b>	37	1.4	88.87									
	<b>24</b>	52	1.0	124.81									
	<b>16.5</b>	76	0.7	181.35									
	<b>160</b>	8	7.9	18.75		<b>100/146</b>	120/240/24E*						
	<b>131</b>	10	6.5	22.89	120.66/240.66								
	<b>115</b>	11	5.7	26.17									
	<b>106</b>	12	5.3	28.26									
	<b>86</b>	15	5.3	35.07									
	<b>76</b>	17	4.7	39.44									
	<b>65</b>	19	4.0	46.44									
	<b>57</b>	22	3.5	52.86									
	<b>49</b>	25	3.4	60.63									
	<b>43</b>	29	2.9	70.00									



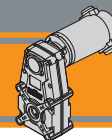

Dati tecnici

Technical data

P <sub>1</sub> [W]	n <sub>2</sub> [min <sup>-1</sup> ]	M <sub>2</sub> [Nm]	sf	i		Versione motore Motor version
<b>800</b>						
(3000 min <sup>-1</sup> )	<b>207</b>	35	3.1	14.49	<b>600/176</b>	120/240
	<b>173</b>	41	2.8	17.31		120.66/240.66
	<b>143</b>	50	2.5	20.97		
	<b>122</b>	59	2.4	24.56		
	<b>102</b>	70	2.0	29.33		
	<b>87</b>	83	1.8	34.62		
	<b>80</b>	90	1.7	37.50		
	<b>73</b>	99	1.6	41.35		
	<b>67</b>	107	1.5	44.79		
	<b>60</b>	120	1.4	50.10		
	<b>55</b>	130	1.4	54.26		
	<b>47</b>	152	1.2	63.55		
	<b>40</b>	182	1.1	75.90		
	<b>35</b>	204	1.0	85.40		
	<b>33</b>	214	1.0	89.60		
	<b>28</b>	256	0.9	107.02		
	<b>24</b>	304	0.8	126.92		

P <sub>1</sub> [W]	n <sub>2</sub> [min <sup>-1</sup> ]	M <sub>2</sub> [Nm]	sf	i		Versione motore Motor version
<b>800</b>						
(3000 min <sup>-1</sup> )	<b>147</b>	49	5.6	20.41	<b>600/196</b>	120/240
	<b>86</b>	83	3.7	34.81		120.66/240.66
	<b>70</b>	102	3.4	42.61		
	<b>51</b>	142	2.7	59.36		
	<b>41</b>	174	2.5	72.68		
	<b>32</b>	222	1.9	92.82		
	<b>24</b>	297	1.4	123.95		
	<b>19</b>	378	1.1	158.02		
	<b>15</b>	483	0.9	201.80		

Motori applicabili

Motor adapters

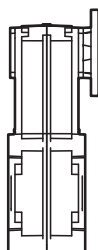
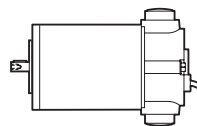

		EC					
		070.12E 070.24E	100.120 100.240 100.24E	180.120 180.240	180.24E	250.120 250.240	350.120 350.240
FT	105/3	20.57 - 315.05					
	105/4	368.19 - 929.4					
	146	18.75 - 397.38	* 18.75 - 397.38		18.75 - 397.38	18.75 - 397.38	
	176			* 14.49 - 390.11	14.49 - 390.11		
	196			* 20.41 - 269.47	20.41 - 269.47		

20.57 - 315.05

Rapporti di riduzione i  
Ratio i

\*: Motore inclinato con portaspazzole a 45°  
Motor assembly with brush holder inclined 45°

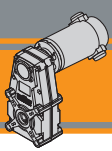

**ECFT 070/105**

**ECFT 070/105...U**

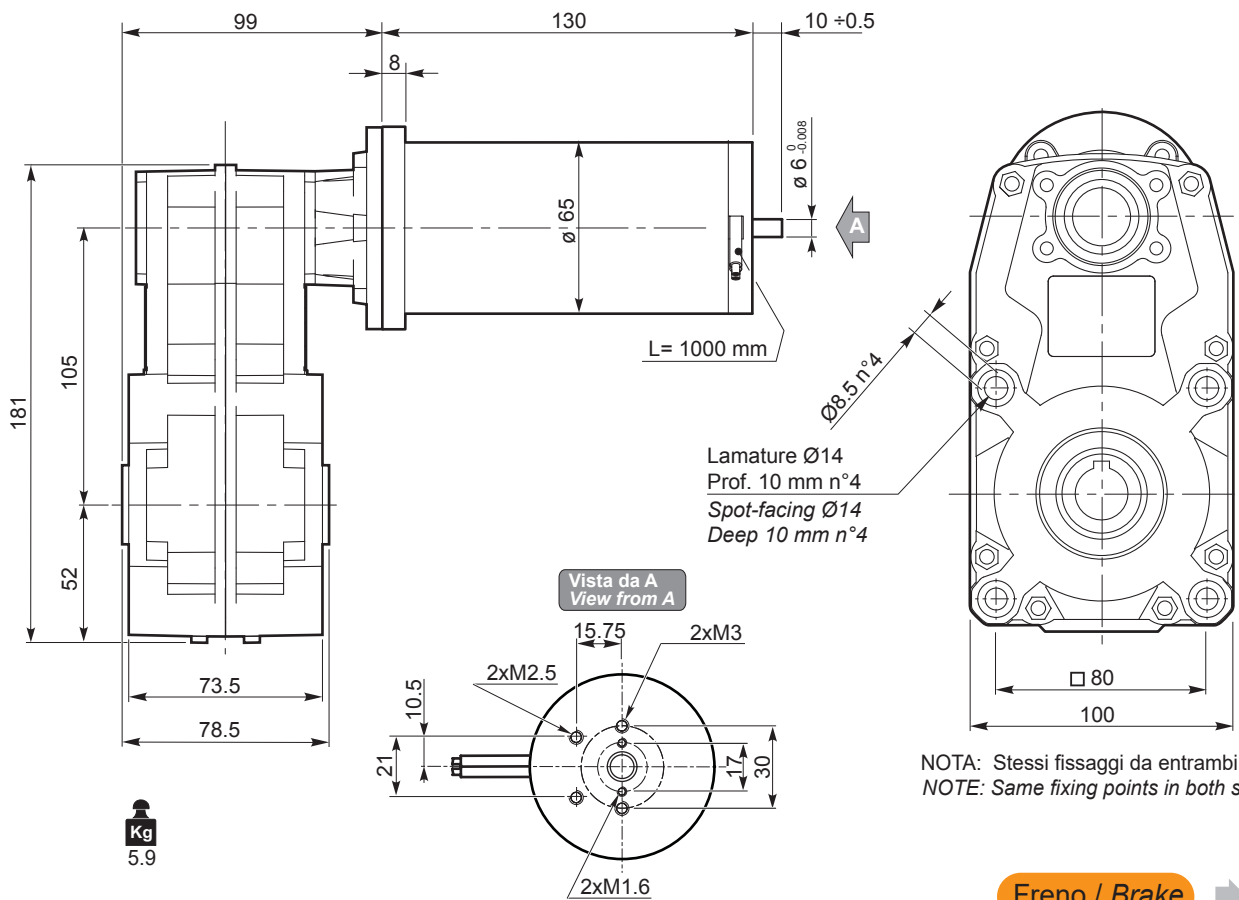

NOTA: Stessi fissaggi da entrambi i lati  
NOTE: Same fixing points in both sides

- Freno / Brake** → I23
- Encoder** → I24
- Motori / Motors IP66** → L2

**O17**

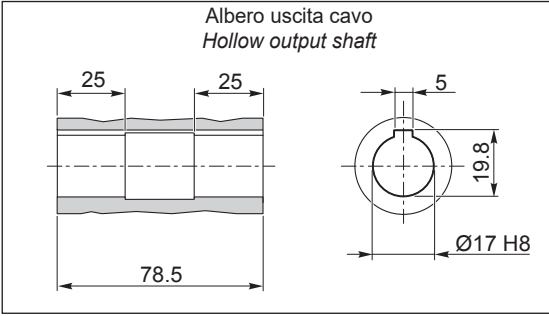

**O20**

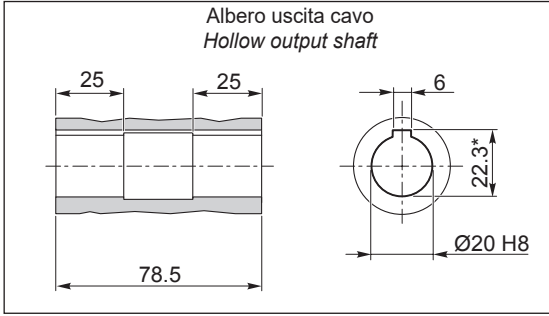

\*: Sede linguetta ribassata / Special keyway

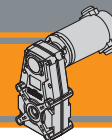

Dimensioni

Dimensions

ECFT 100/105

ECFT 100/105...U

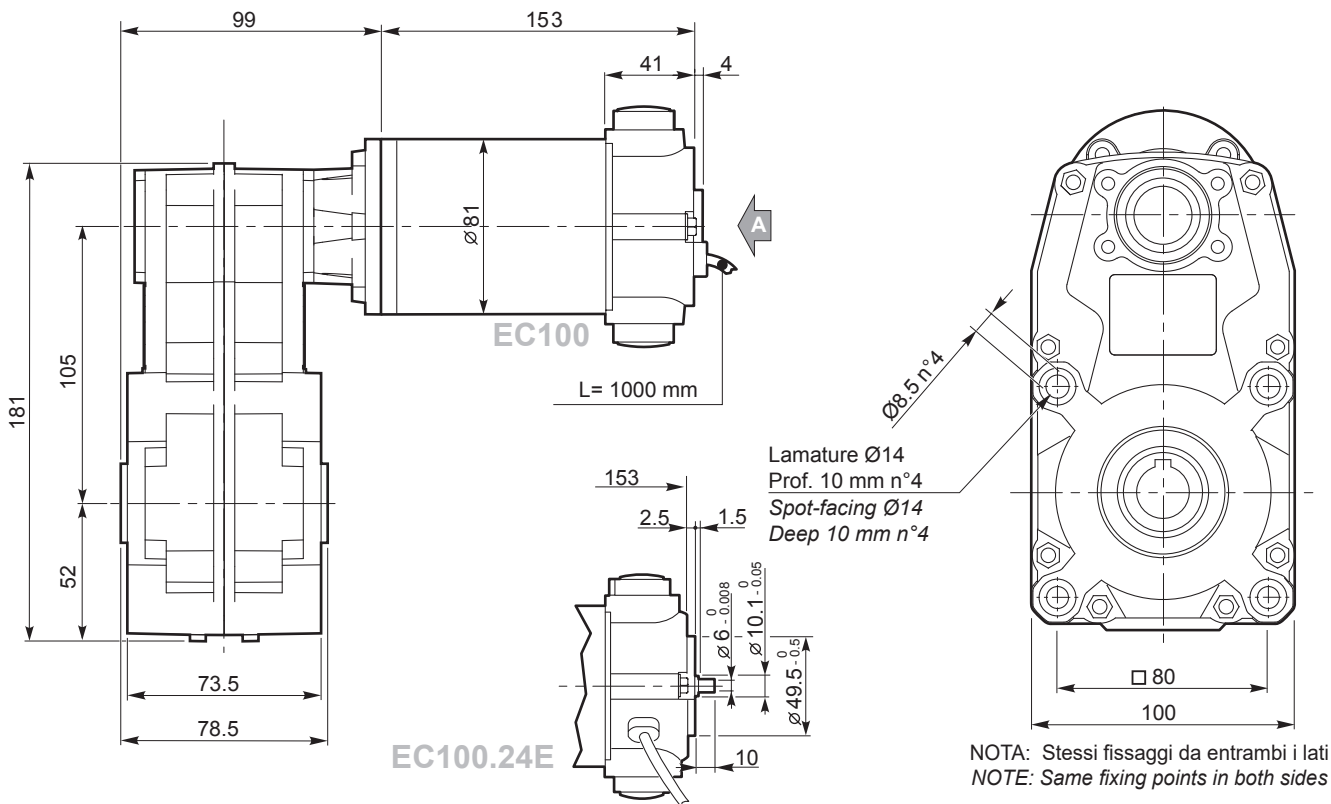

**Kg**  
6.9

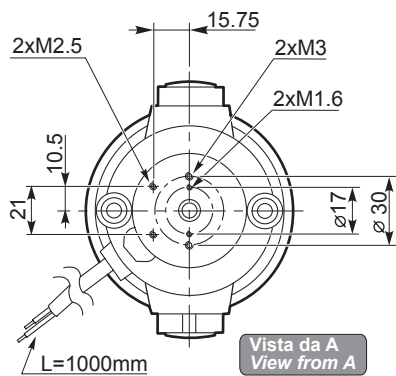

- Freno / Brake → I23
- Encoder → I24
- Motori / Motors IP66 → L4

O17

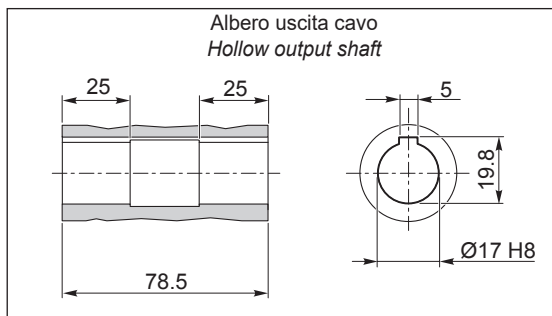

O20

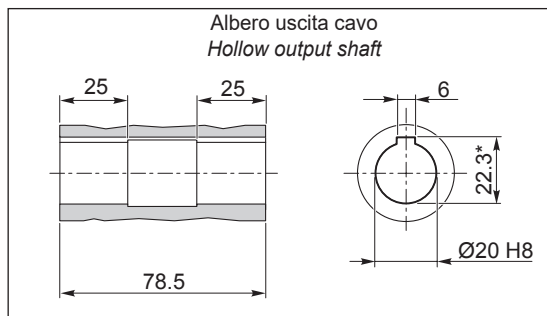

\*: Sede linguetta ribassata / Special keyway

ECFT

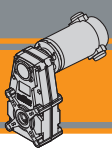

**ECFT 180/105**

**ECFT 180/105...U**

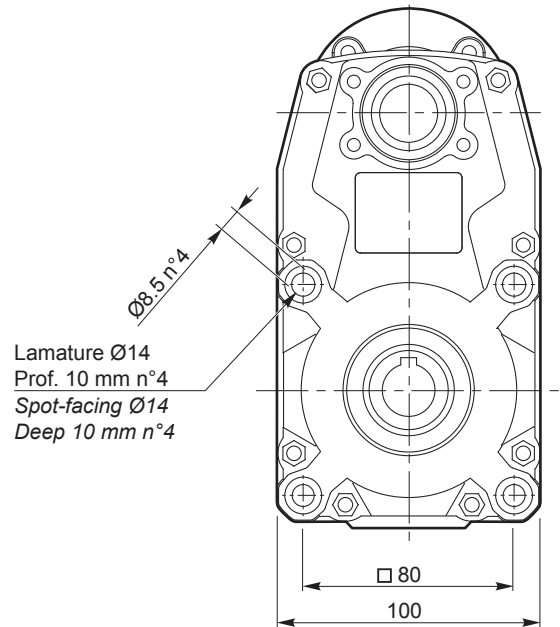
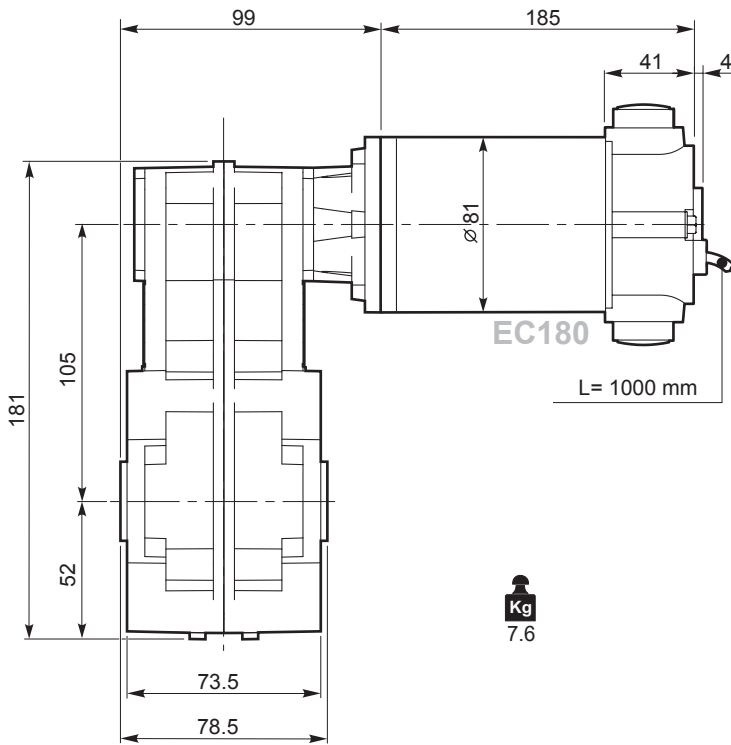

NOTA: Stessi fissaggi da entrambi i lati  
NOTE: Same fixing points in both sides

- Freno / Brake → I23
- Encoder → I24
- Motori / Motors IP66 → L6

**O17**

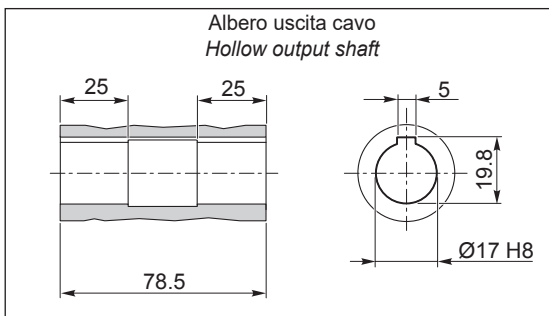

**O20**

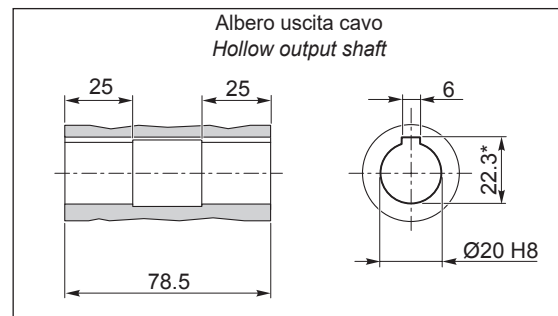

\*: Sede linguetta ribassata / Special keyway

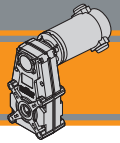

Dimensioni

Dimensions

ECFT 070/146

ECFT 070/146 U

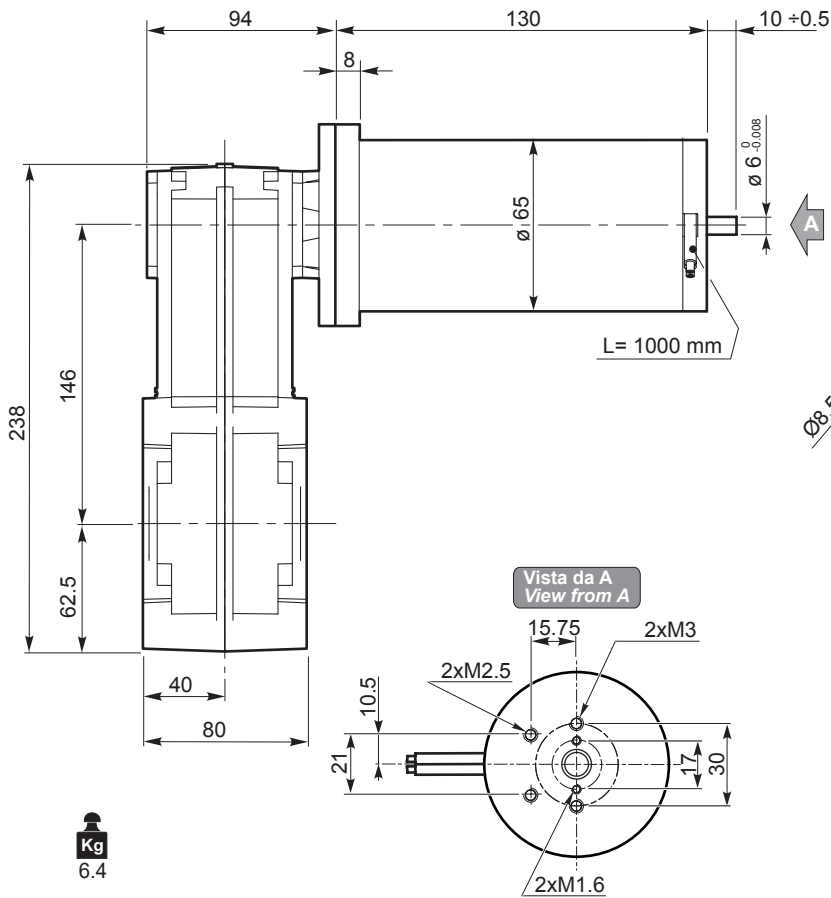

**Kg**  
6.4

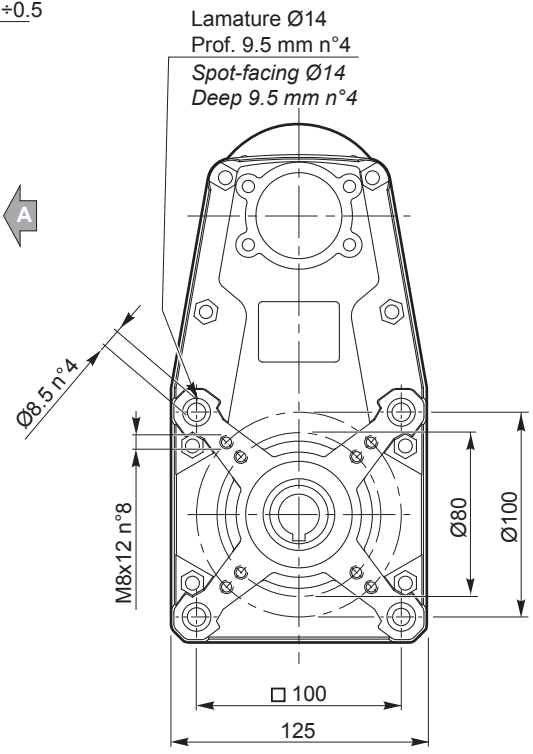

NOTA: Stessi fissaggi da entrambi i lati  
NOTE: Same fixing points in both sides

Freno / Brake → I23

Encoder → I24

Motori / Motors IP66 → L2

O20

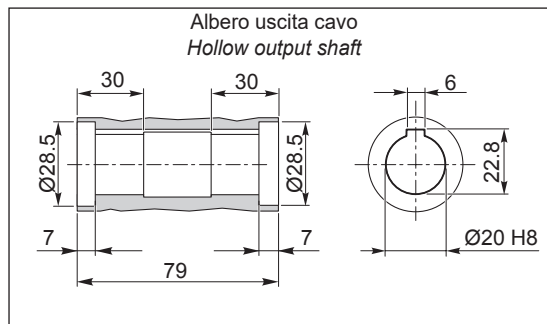

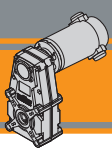

## ECFT 100/146

### ECFT 100/146 U

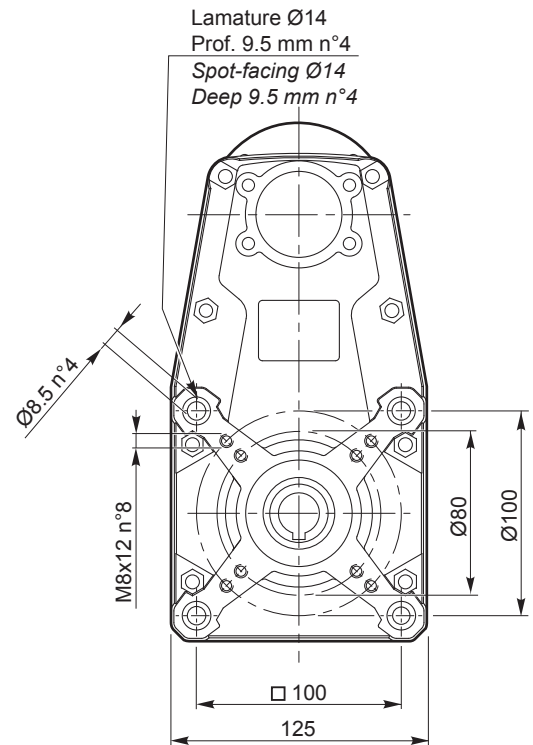
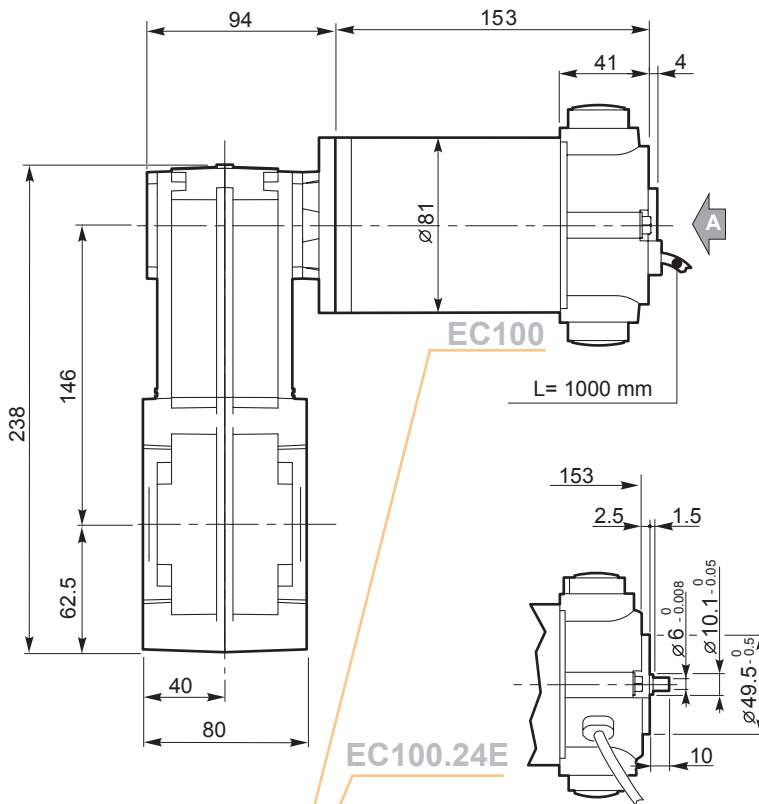

NOTA: Stessi fissaggi da entrambi i lati  
NOTE: Same fixing points in both sides

**Kg**  
7.4

**Nota:** Motore inclinato con portaspazzole a 45°  
**Note:** Motor assembly with brush holder inclined 45°

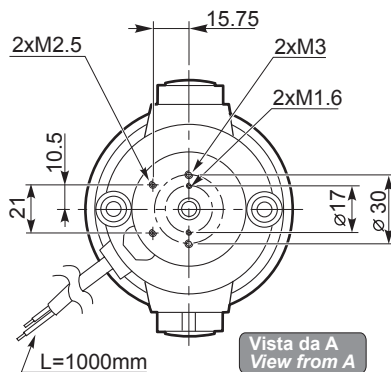

- Freno / Brake → I23
- Encoder → I24
- Motori / Motors IP66 → L4

### O20

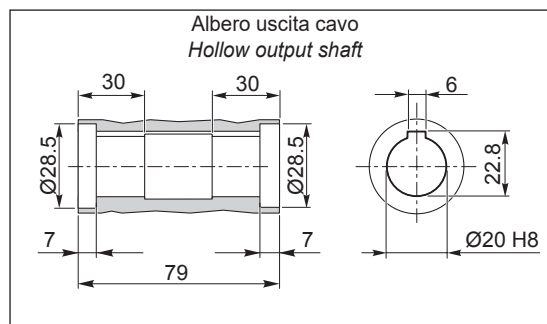

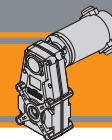

Dimensioni

Dimensions

ECFT 180/146

ECFT 180/146 U

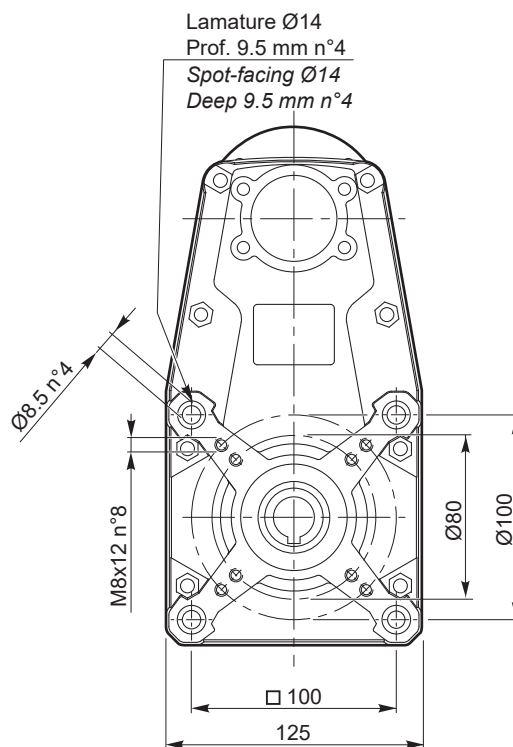
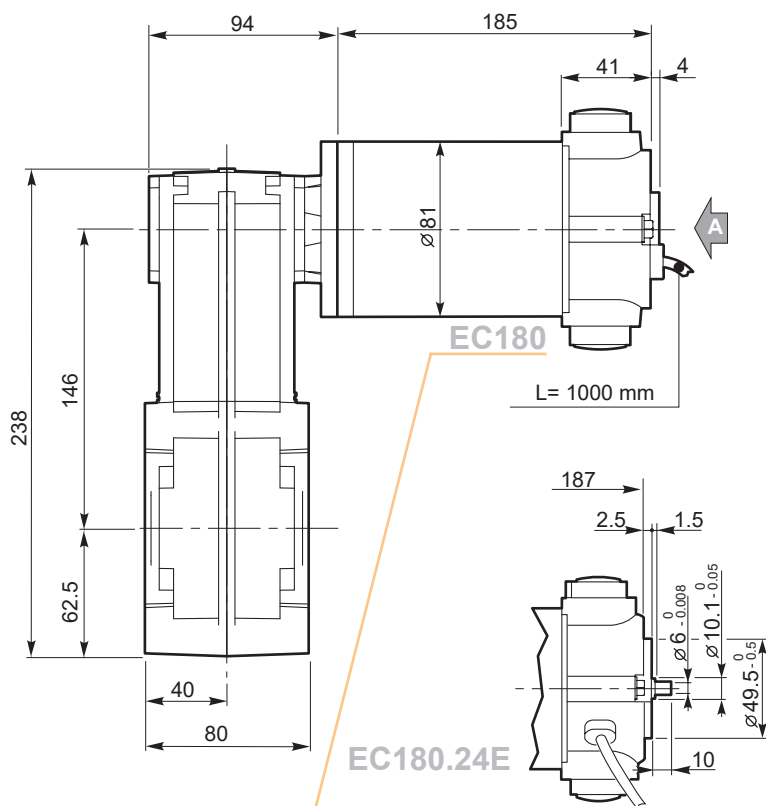

NOTA: Stessi fissaggi da entrambi i lati  
NOTE: Same fixing points in both sides

**Kg**  
8.1

**Nota:** Motore inclinato con portaspazzole a 45°  
**Note:** Motor assembly with brush holder inclined 45°

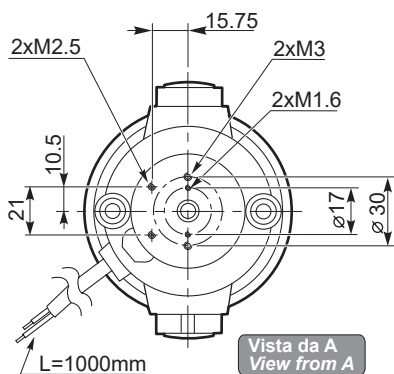

- Freno / Brake → I23
- Encoder → I24
- Motori / Motors IP66 → L6

O20

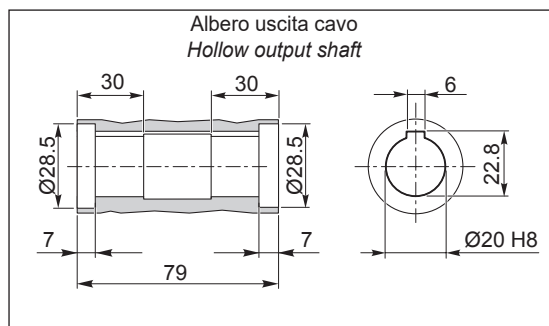

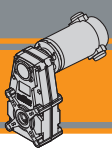

**ECFT 250/146**

**ECFT 250/146 U**

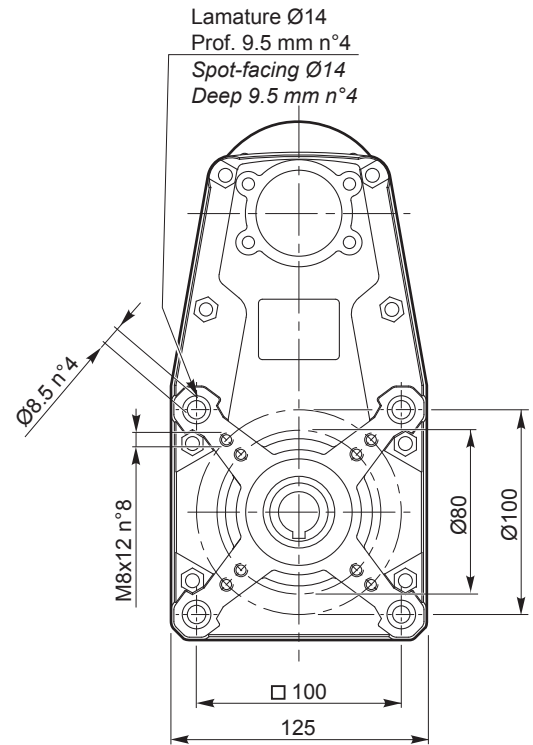
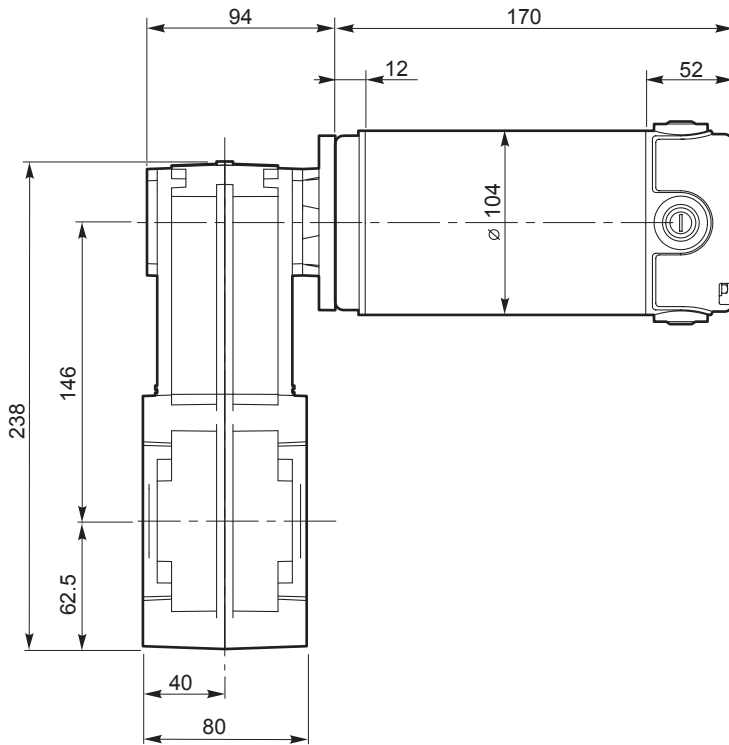

**Kg**  
8.9

NOTA: Stessi fissaggi da entrambi i lati  
NOTE: Same fixing points in both sides

Motori / Motors IP66

L8

**O20**

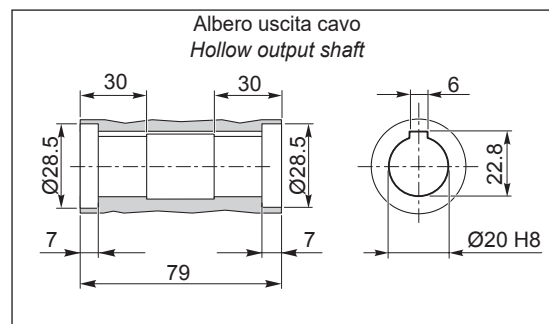

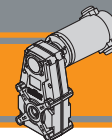

Dimensioni

Dimensions

ECFT 350/146

ECFT 350/146 U

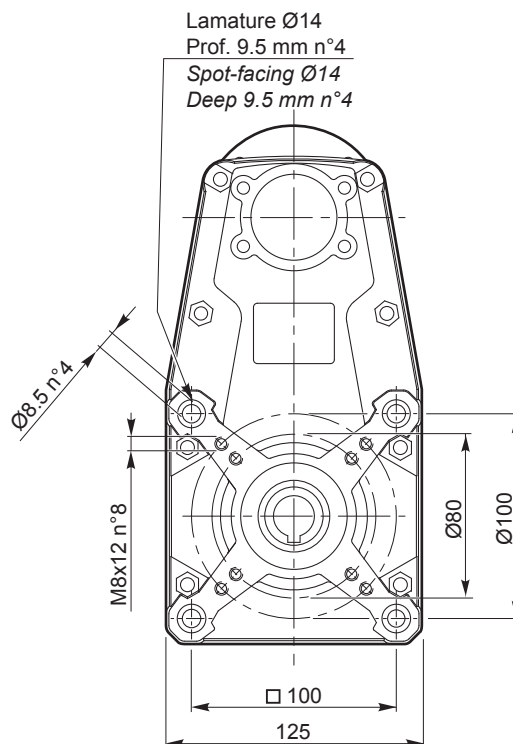
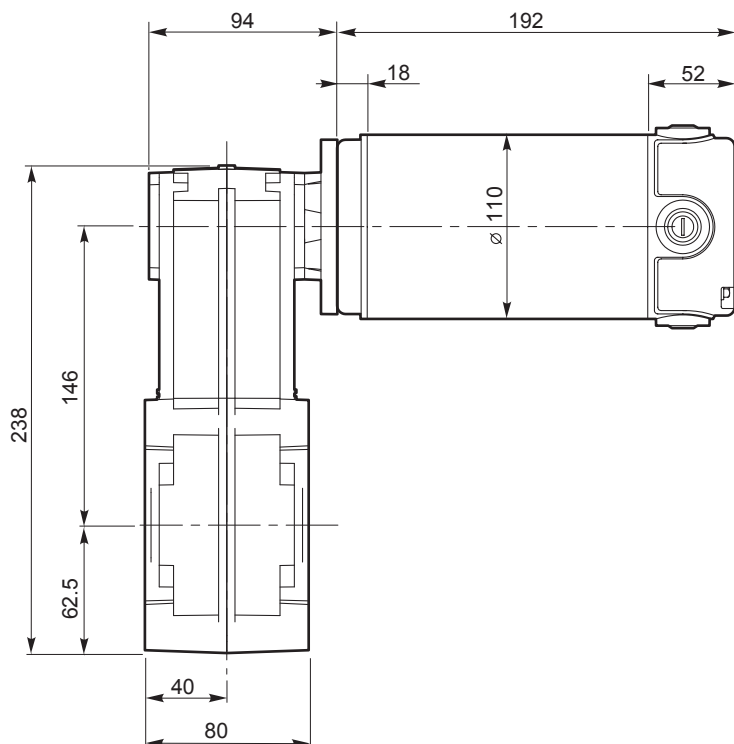

NOTA: Stessi fissaggi da entrambi i lati  
NOTE: Same fixing points in both sides

**Kg**  
10.0

Freno / Brake

I23

Motori / Motors IP66

L10

O20

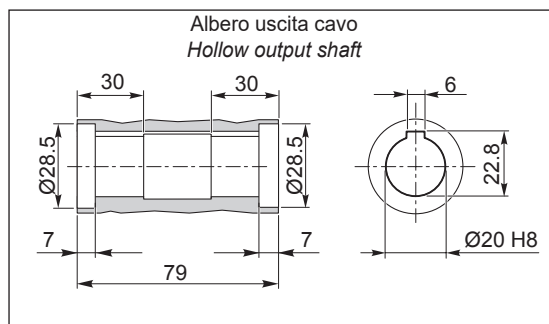

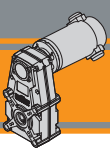

## ECFT 600/146

### ECFT 600/146 U

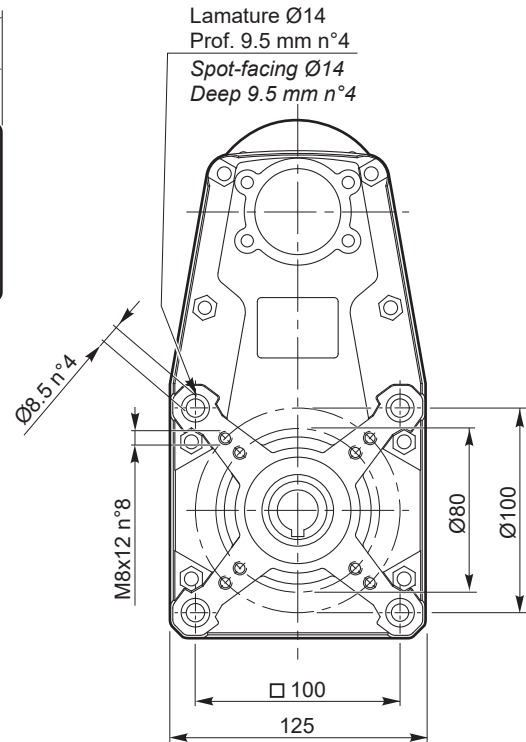
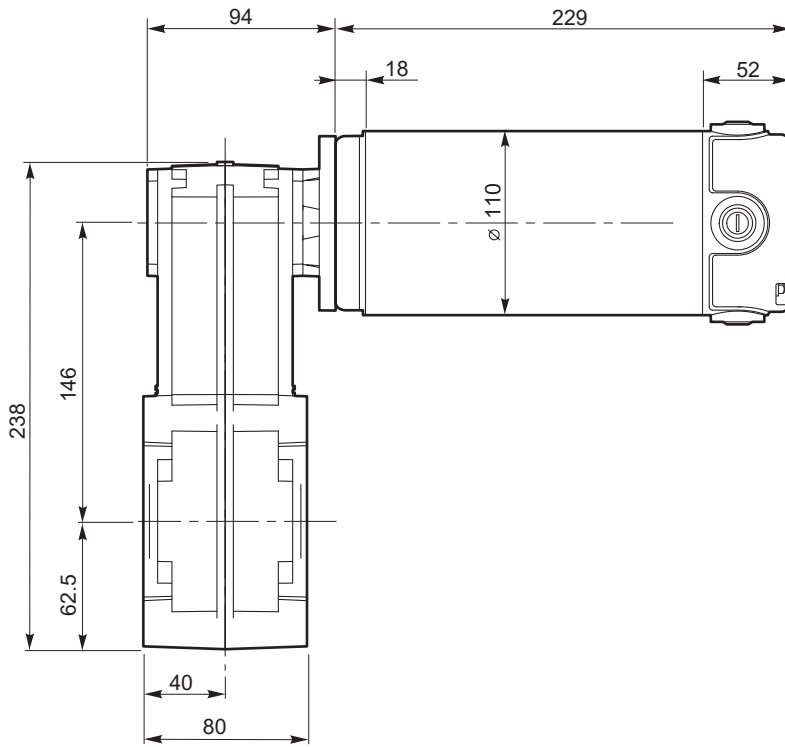

**Kg**  
11.8

NOTA: Stessi fissaggi da entrambi i lati  
NOTE: Same fixing points in both sides

Freno / Brake



L23

Motori / Motors IP66



L10

### O20

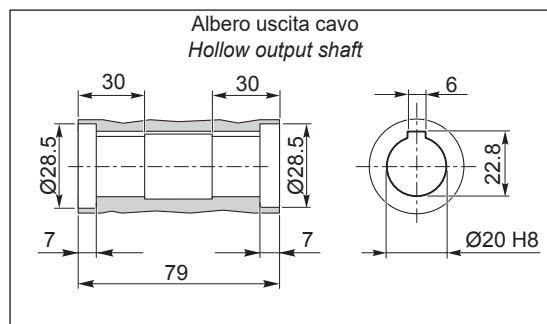

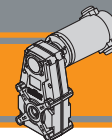

Dimensioni

Dimensions

ECFT 180/176.24E

ECFT 180/176.24E U

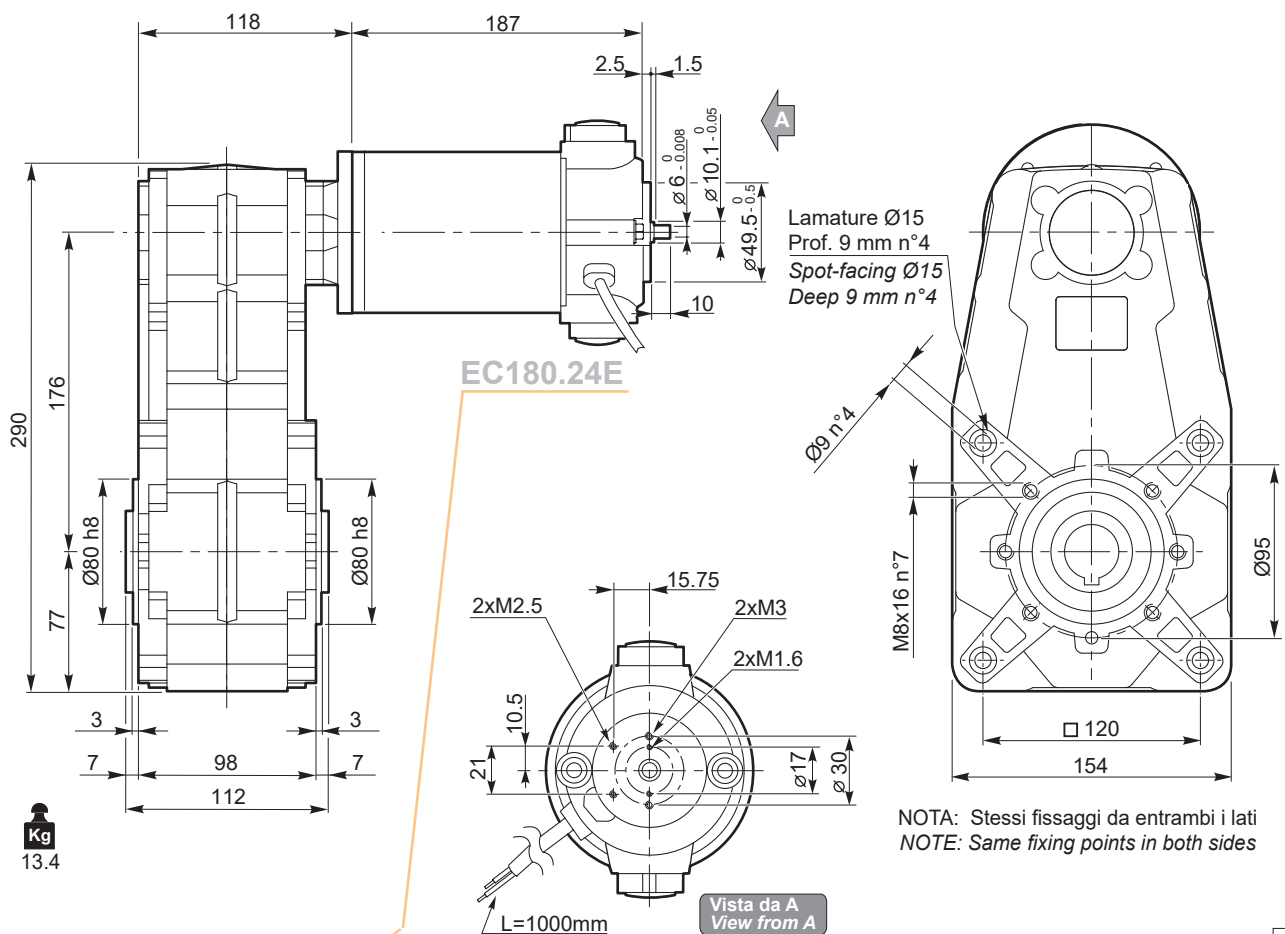

**Nota:** Motore inclinato con portaspazzole a 45°  
**Note:** Motor assembly with brush holder inclined 45°

Encoder → I24

O25

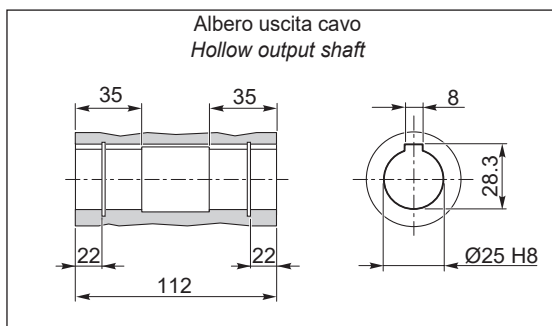

O30

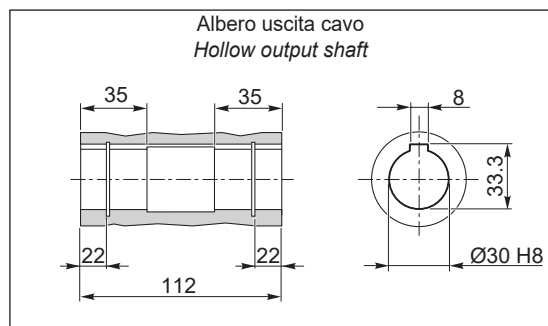

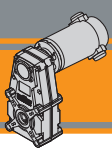

## ECFT 250/176

### ECFT 250/176 U

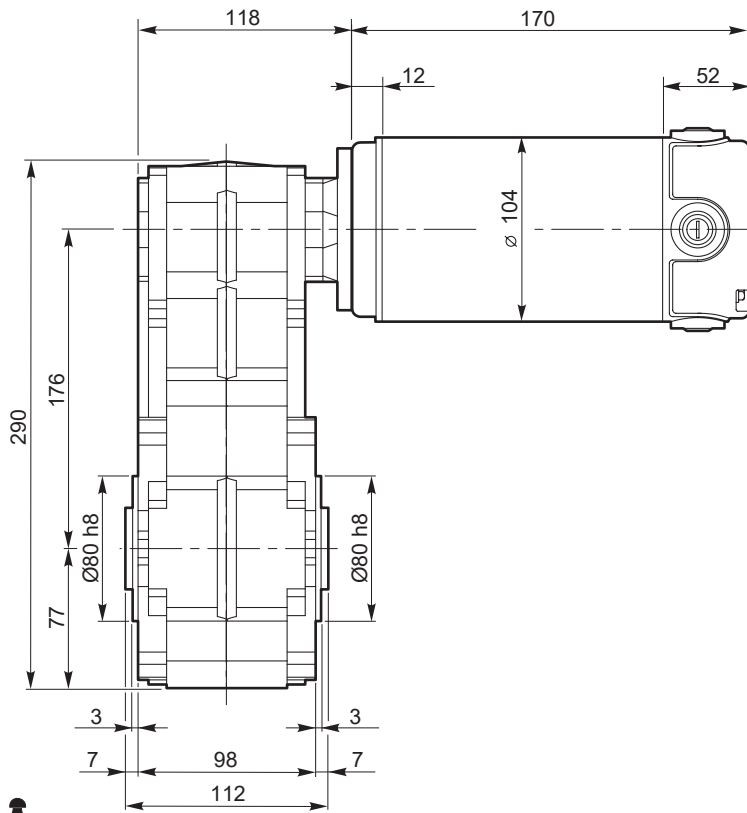

Lamature Ø15  
Prof. 9 mm n°4  
Spot-facing Ø15  
Deep 9 mm n°4

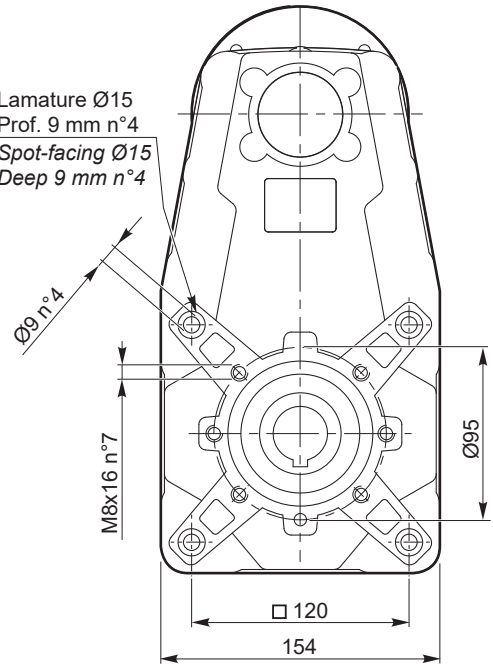

**Kg**  
14.2

Motori / Motors IP66

L10

### O25

Albero uscita cavo  
Hollow output shaft

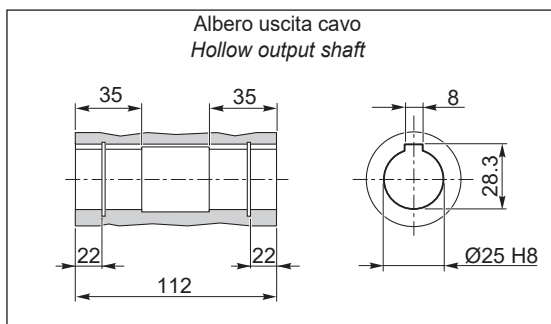

### O30

Albero uscita cavo  
Hollow output shaft

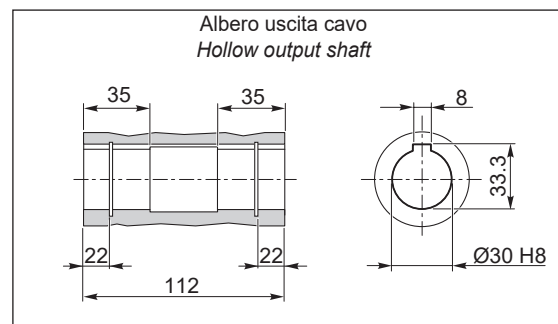

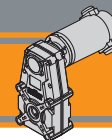

Dimensioni

Dimensions

ECFT 350/176

ECFT 350/176 U

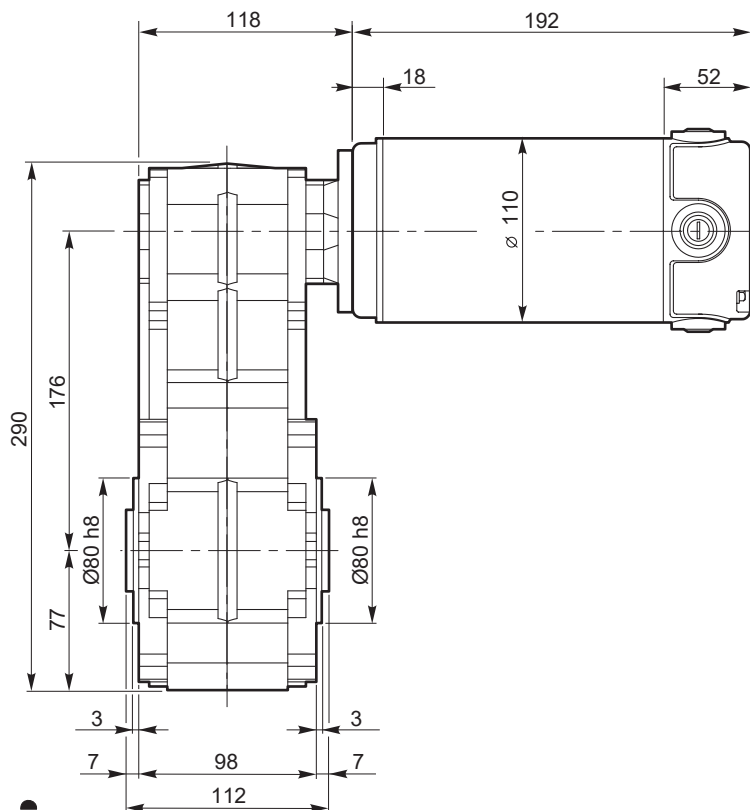

Lamature Ø15  
Prof. 9 mm n°4  
Spot-facing Ø15  
Deep 9 mm n°4

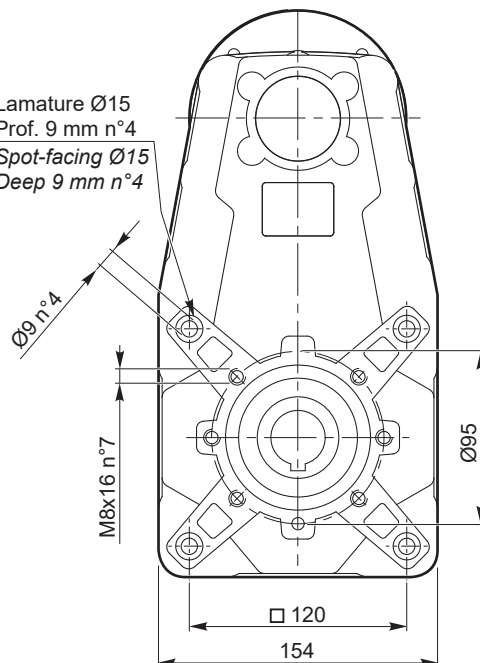

**Kg**  
15.3

Freno / Brake → I23

Motori / Motors IP66 → L10

O25

Albero uscita cavo  
Hollow output shaft

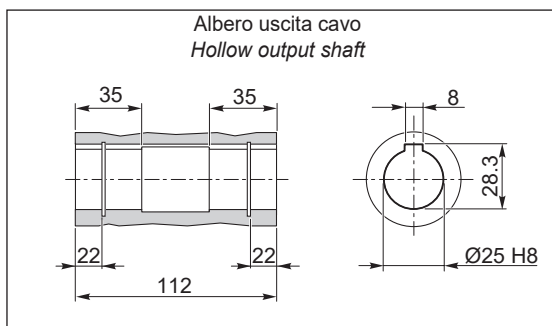

O30

Albero uscita cavo  
Hollow output shaft

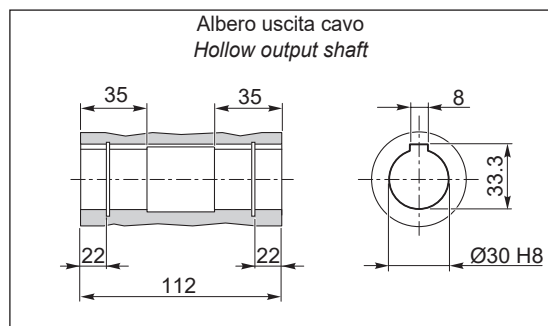

ECFT

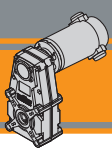

## ECFT 600/176

### ECFT 600/176 U

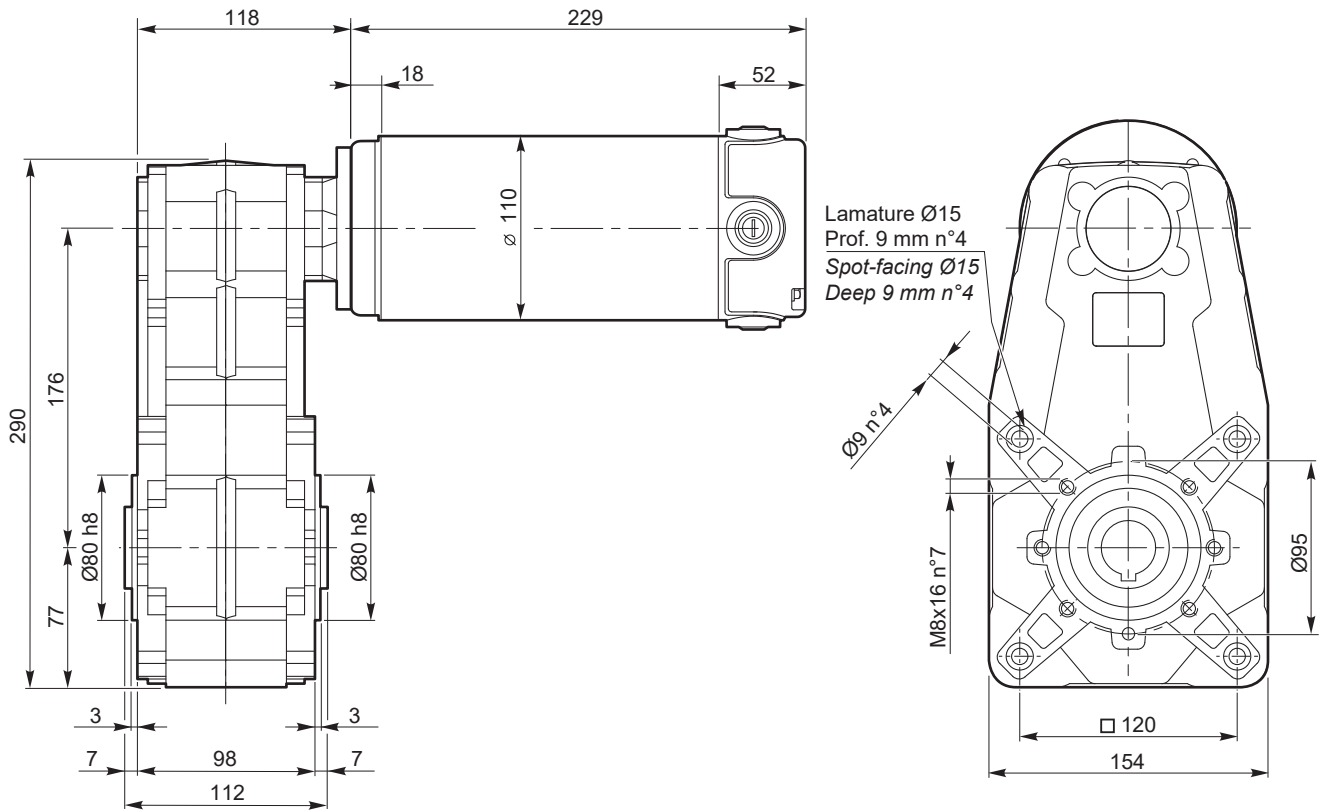

**Kg**  
17.1

Freno / Brake

I23

Motori / Motors IP66

L10

### O25

Albero uscita cavo  
Hollow output shaft

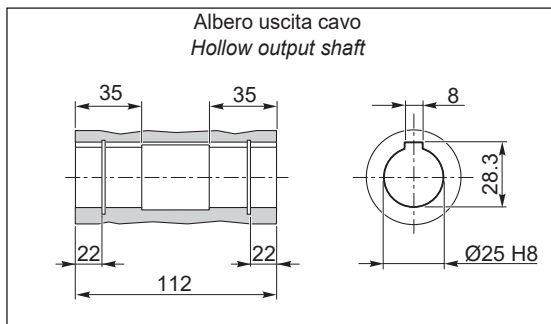

### O30

Albero uscita cavo  
Hollow output shaft

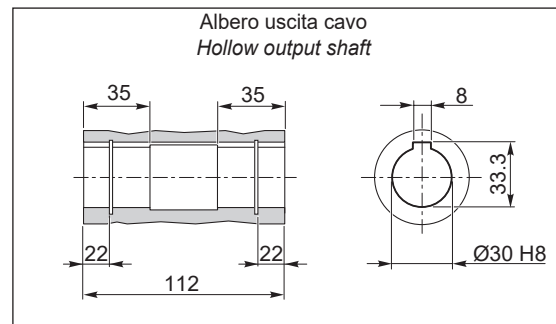

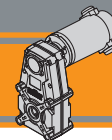

Dimensioni

Dimensions

ECFT 180/196.24E

ECFT 180/196.24E U

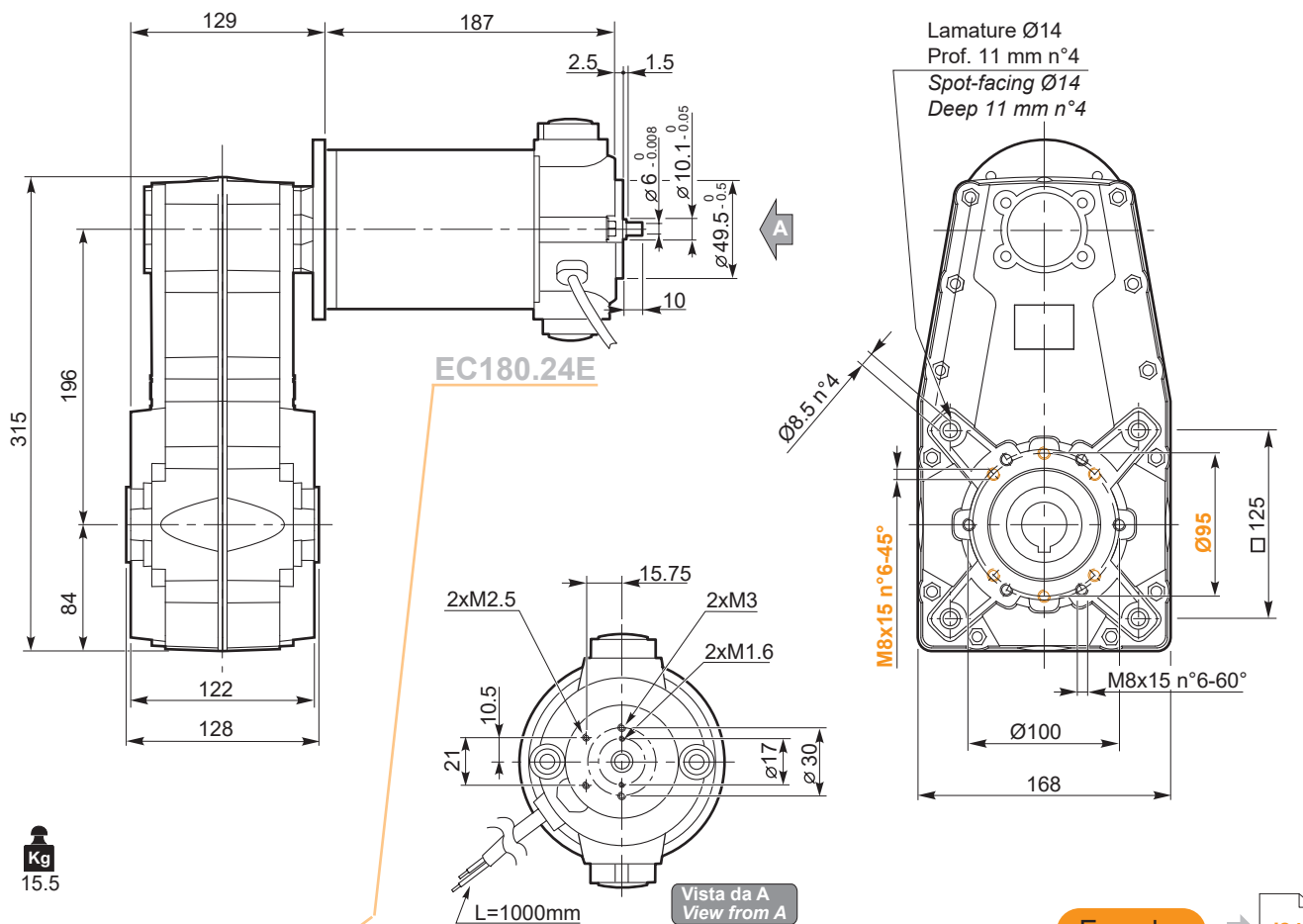

**Nota:** Motore inclinato con portaspazzole a 45°  
**Note:** Motor assembly with brush holder inclined 45°

Encoder → I24

O30

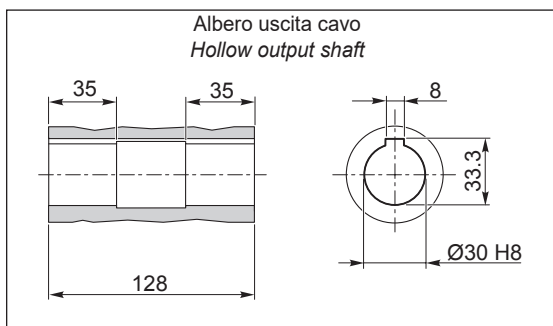

O35

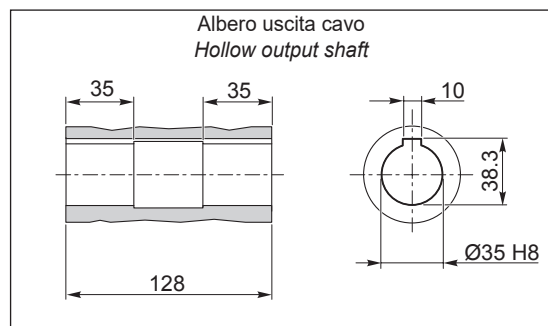

ECFT

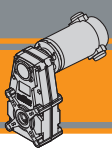

### ECFT 250/196

#### ECFT 250/196 U

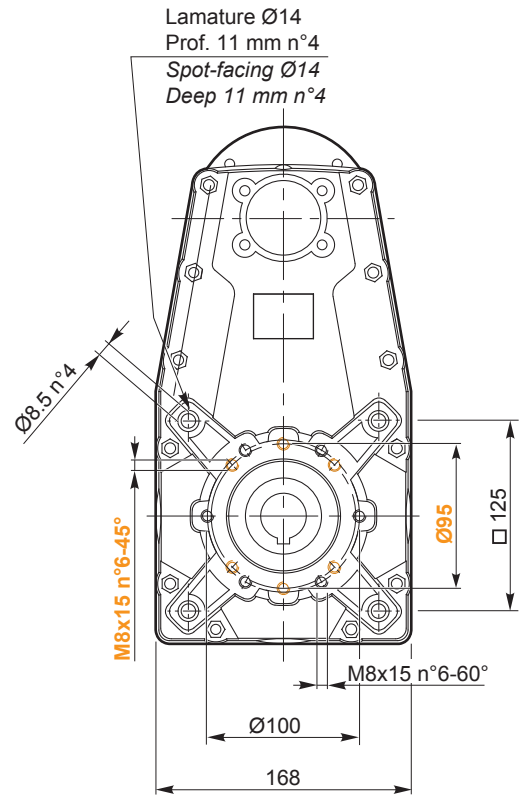
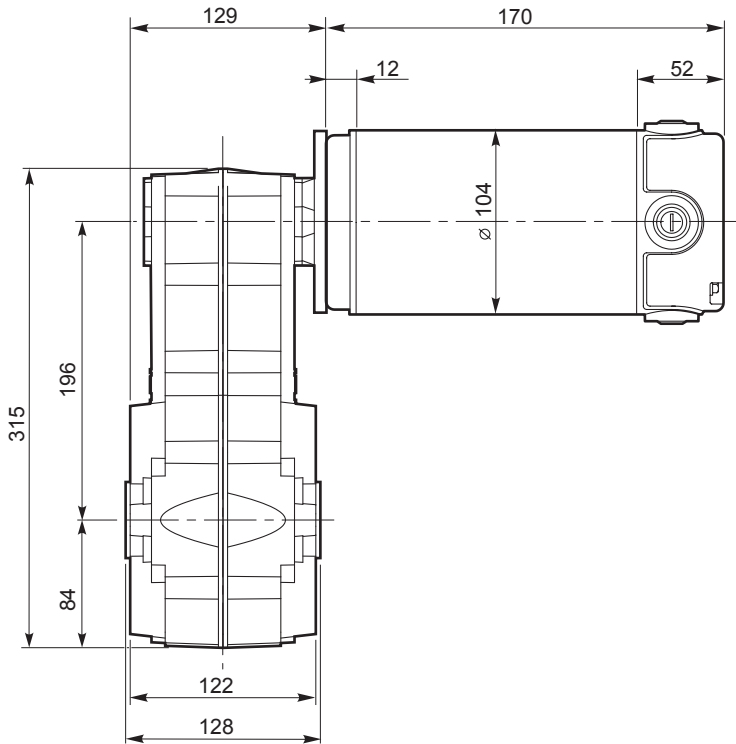

**Kg**  
16.3

NOTA: Stessi fissaggi da entrambi i lati  
NOTE: Same fixing points in both sides

Motori / Motors IP66

L8

#### O30

Albero uscita cavo  
Hollow output shaft

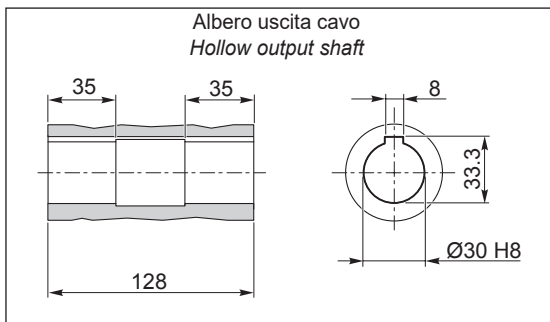

#### O35

Albero uscita cavo  
Hollow output shaft

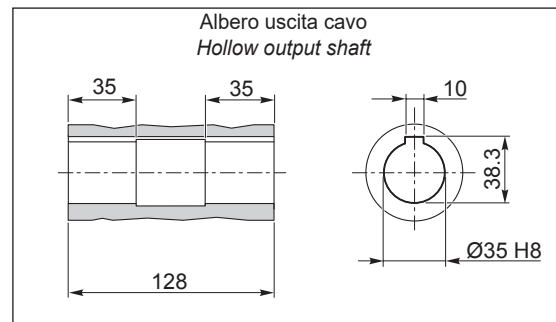

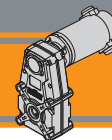

Dimensioni

Dimensions

ECFT 350/196

ECFT 350/196 U

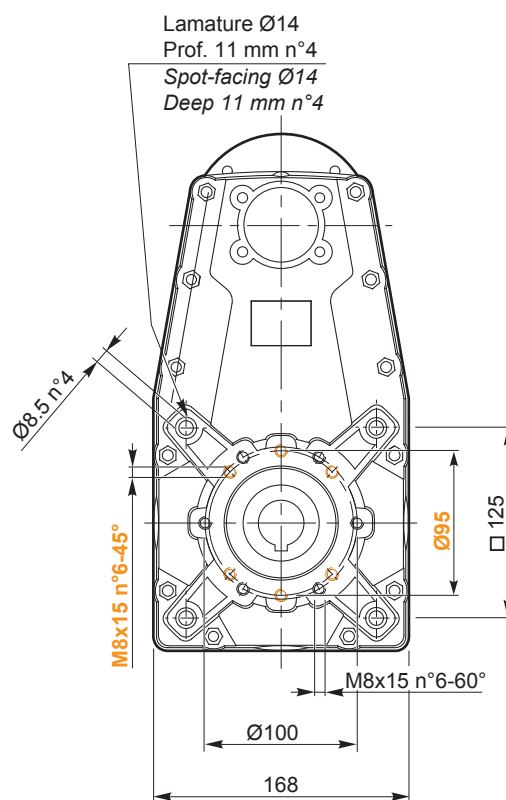
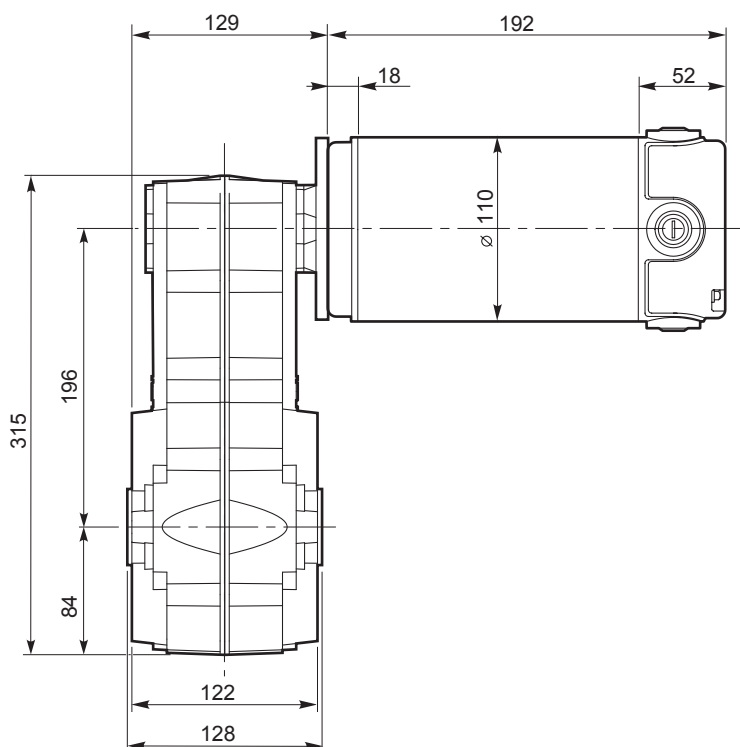

**Kg**  
17.4

NOTA: Stessi fissaggi da entrambi i lati  
NOTE: Same fixing points in both sides

Freno / Brake

I23

Motori / Motors IP66

L10

O30

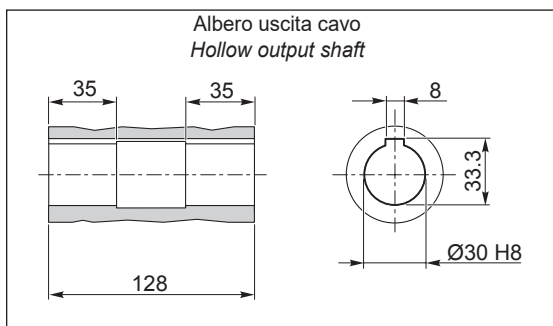

O35

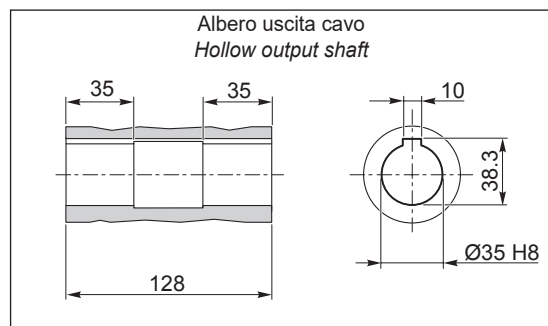

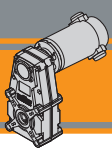

### ECFT 600/196

#### ECFT 600/196 U

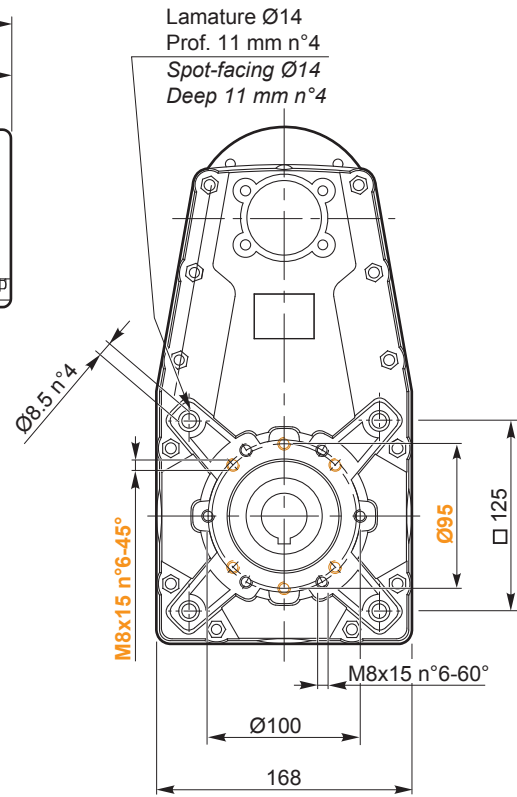
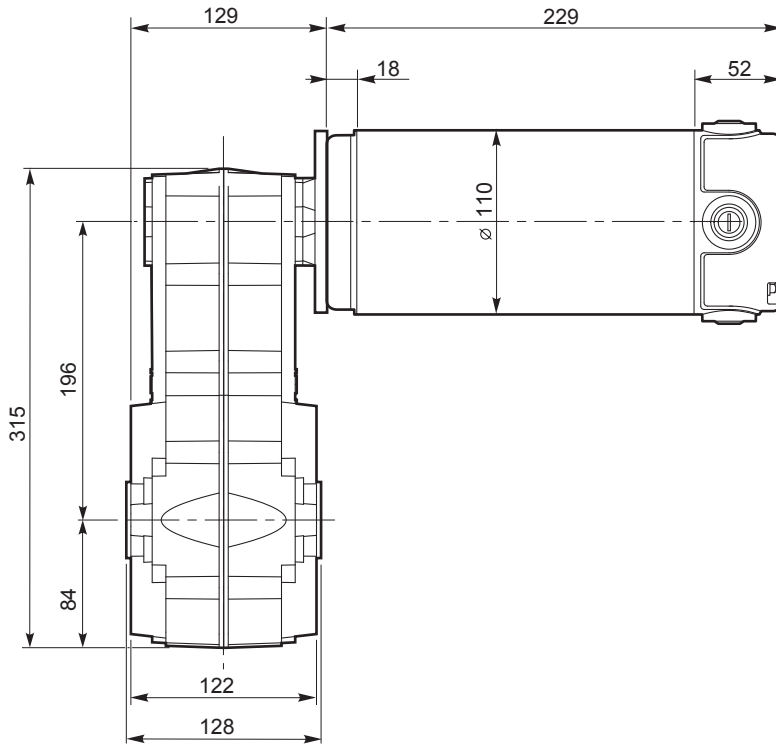

**Kg**  
19.2

NOTA: Stessi fissaggi da entrambi i lati  
NOTE: Same fixing points in both sides

Freno / Brake

I23

Motori / Motors IP66

L12

#### O30

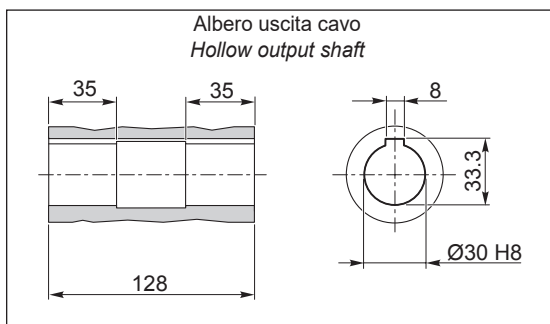

#### O35

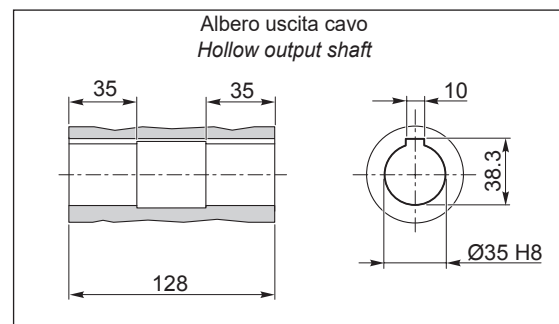



Ferrite

Motoriduttori CC a vite senza fine  
**DC wormgearmotors**

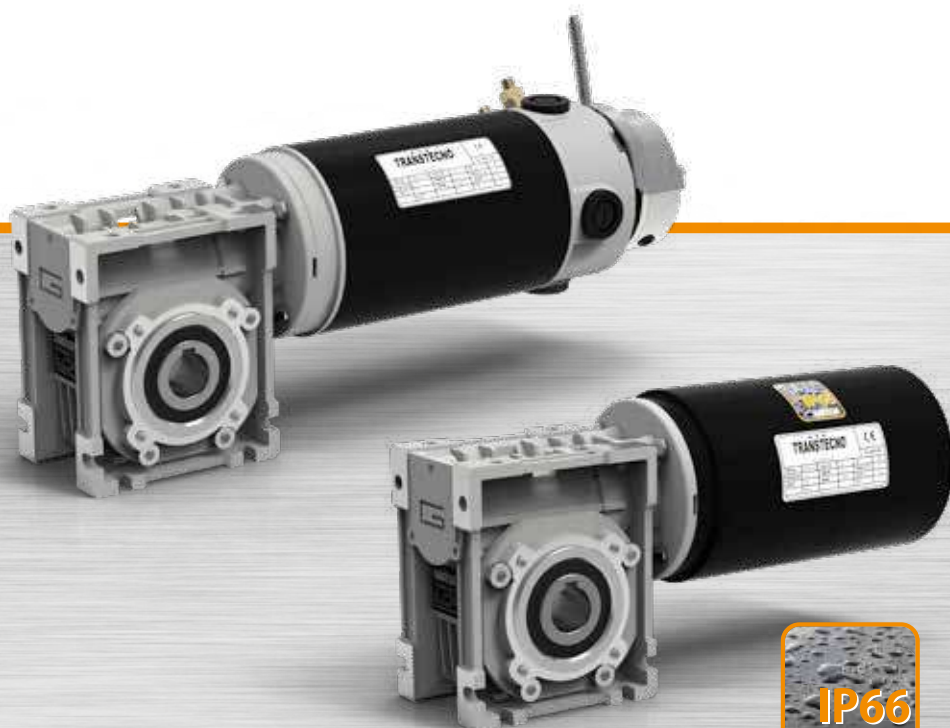



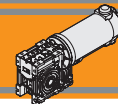

<b>Indice</b>	<b>Index</b>	Pag. Page
Caratteristiche tecniche	<i>Technical features</i>	<b>P2</b>
Designazione	<i>Classification</i>	<b>P2</b>
Simbologia	<i>Symbols</i>	<b>P2</b>
Lubrificazione	<i>Lubrication</i>	<b>P3</b>
Carichi radiali	<i>Radial loads</i>	<b>P3</b>
Dati di dentatura	<i>Toothing data</i>	<b>P4</b>
Rendimento	<i>Efficiency</i>	<b>P4</b>
Dati tecnici per servizio S2	<i>Technical data for S2 duty</i>	<b>P5</b>
Motori applicabili	<i>Motor adapters</i>	<b>P6</b>
Dimensioni	<i>Dimensions</i>	<b>P7</b>
Opzioni	<i>Options</i>	<b>P20</b>
Accessori	<i>Accessories</i>	<b>P20</b>

Questa sezione annulla e sostituisce ogni precedente edizione o revisione. Qualora questa sezione non Vi sia giunta in distribuzione controllata, l'aggiornamento dei dati ivi contenuto non è assicurato. **In tal caso la versione più aggiornata è disponibile sul nostro sito internet [www.transtecno.com](http://www.transtecno.com)**

*This section replaces any previous edition and revision. If you obtained this catalogue other than through controlled distribution channels, the most up to date content is not guaranteed. **In this case the latest version is available on our web site [www.transtecno.com](http://www.transtecno.com)***

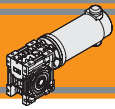

**Caratteristiche tecniche**

**Technical features**

Le caratteristiche principali dei motoriduttori CC a vite senza fine a magneti permanenti in ferrite serie ECM sono:

The main features of ECM ferrite permanent magnets DC wormgearmotors range are:

- Alimentazione in bassa tensione 12/24 Vcc
- Possibilità di montaggio encoder
- Potenze motore disponibili da 100 a 800W S2
- Magneti in ferrite
- Carcasse dei riduttori in pressofusione di alluminio
- Lubrificazione permanente con olio sintetico.

- Low voltage power supply 12/24 Vdc
- Suitable for encoder assembly
- Motor power ratings available from 100 to 800W S2
- Ferrite magnets
- Die-cast aluminum housing
- Permanent synthetic oil long-life lubrication.

**Designazione**

**Classification**

MOTORIDUTTORE / GEARMOTOR														
ECM	070/026						U	10	SZDX	BRSX	90	240	VS	SC
Tipo Type	Grandezza Size						Versione Riduttore Gearbox Version	Rapporto Ratio	Albero di uscita Output shaft	Braccio di reazione Torque arm	Angolo Angle	Versione Motore Motor Version	Opzioni Options	Accessori Accessories
 ECM	070/026	100/026	180/026	250/030	350/030	600/040	<b>U</b> F...	Vedere tabella  See tables	<b>SZDX</b> <b>SZSX</b> <b>DZ</b>	<b>BRDX</b> <b>BRSX</b>	<b>0°</b> <b>90°</b> <b>180°</b> <b>270°</b>	<b>120</b> <b>240</b> <b>24E</b>	<b>VS**</b>	<b>SC</b> Safety cover  <b>WD</b> Washdown cover
	070/026 (D11) 070/026 (D14) 070/030	100/0026 (D11) 100/026 (D14) 100/030 100/040	180/026 (D11) 180/026 (D14) 180/030 180/040 180/050	250/040 250/050 250/063	350/040 350/050 350/063 350/070	600/050 600/063 600/070								

Versione Riduttore  
Gearbox Version

Albero di uscita  
Output shaft

Braccio di reazione  
Torque arm

Angolo  
Angle

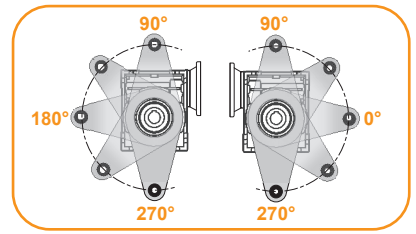
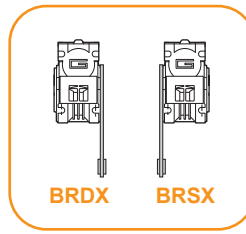
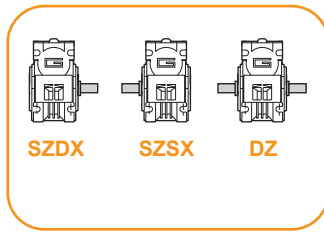
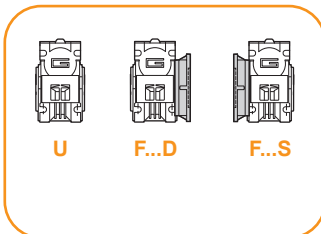

\* NOTA: il braccio di reazione viene fornito smontato.  
NOTE: the torque arm will be supplied not assembled.

\*\* NOTA: Vite sporgente costruita su richiesta  
NOTE: Extended input shaft built on request

**Simbologia**

**Symbols**

$n_1$ [min <sup>-1</sup> ]	Velocità in ingresso / Input speed	$R_d$ %	Rendimento dinamico / Dynamic efficiency
$n_2$ [min <sup>-1</sup> ]	Velocità in uscita / Output speed	$A_2$ [N]	Carico assiale ammissibile in uscita / Permitted output axial load
$i$	Rapporto di riduzione / Ratio	$R_s$ %	Rendimento statico / Static efficiency
$P_1$ [kW]	Potenza in entrata / Input power	$R_2$ [N]	Carico radiale ammissibile in uscita / Permitted output radial load
$M_2$ [Nm]	Coppia in uscita in funzione di $P_1$ / Output torque referred to $P_1$	$Z$	Numero di principi della vite / Worm starts
$sf$	Fattore di servizio / Service factor	$\beta$	Angolo d'elica / Helix angle



**Lubrificazione**

**Lubrication**

I riduttori a vite senza fine della serie CM sono lubrificati a vita con olio sintetico di viscosità 320 e possono essere installati in qualunque posizione di montaggio.

Permanent synthetic oil long-life lubrication allow to use CM wormgearbox range in all mounting position.

**Carichi radiali**

**Radial loads**

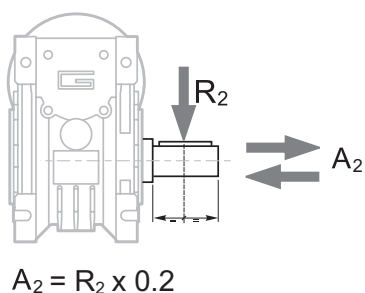

n <sub>2</sub> [min <sup>-1</sup> ]	R <sub>2</sub> [N]					
	CM026	CM030	CM040	CM050	CM063	CM070
600	271	457	857	1200	1657	-
400	310	523	981	1374	1897	2028
300	342	576	1080	1512	2088	2232
200	391	659	1236	1731	2390	2555
150	479	726	1361	1905	2631	2812
120	514	782	1466	2052	2834	3030
100	547	831	1558	2181	3012	3219
75	609	914	1715	2400	3315	3543
60	610	985	1847	2586	3571	3817
50	-	1047	1963	2748	3794	4056
38	-	1147	2151	3011	4158	4445
30	-	1241	2327	3258	4499	4809

Quando il carico radiale risultante non è applicato sulla mezzeria dell'albero occorre calcolare quello effettivo con la seguente formula:

When the resulting radial load is not applied on the centre line of the shaft it is necessary to calculate the effective load with the following formula:

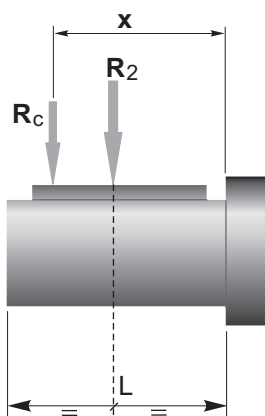

$$R_c = \frac{R_2 \cdot a}{(b + x)} \leq R_{2MAX}$$

$$R \leq R_c$$

a, b = valori riportati nella tabella  
a, b = values given in the table

	CM					
	026	030	040	050	063	070
a	56	65	84	101	120	122
b	43	50	64	76	95	92
R <sub>2MAX</sub>	610	1600	3000	4200	5800	6200

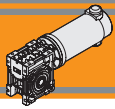

**Dati di dentatura**

**Toothing data**

	Dati della coppia vite-corona Worm wheel data	Rapporto / Ratio											
		5	7.5	10	15	20	25	30	40	50	60	80	100
CM026	Z	6	4	3	2	2		1	1	1	1		
	β	34° 35'	24° 41'	19° 1'	12° 57'	10° 30'		6° 33'	5° 17'	4° 26'	3° 49'		
CM030	Z	6	4	3	2	2	2	1	1	1	1	1	1
	β	27° 4'	24° 28'	18° 50'	12° 49'	10° 23'	8° 43'	6° 29'	5° 14'	4° 23'	3° 46'	2° 57'	2° 25'
CM040	Z	6	4	3	2	2	2	1	1	1	1	1	1
	β	34° 19'	24° 28'	18° 50'	12° 49'	10° 23'	8° 43'	6° 29'	5° 14'	4° 23'	3° 46'	2° 57'	2° 25'
CM050	Z	6	4	3	2	2	2	1	1	1	1	1	1
	β	33° 37'	23° 54'	18° 23'	12° 29'	10° 6'	8° 28'	6° 19'	5° 5'	4° 15'	3° 39'	2° 51'	2° 20'
CM063	Z	6	4	3	2	2	2	1	1	1	1	1	1
	β	34° 23'	24° 31'	18° 53'	12° 50'	10° 24'	8° 44'	6° 30'	5° 14'	4° 23'	3° 47'	2° 57'	2° 25'
CM070	Z		4	3	2	2	2	1	1	1	1	1	1
	β		26° 12'	20° 15'	13° 49'	11° 15'	9° 29'	7° 0'	5° 41'	4° 46'	4° 7'	3° 13'	2° 39'

**Rendimento**

**Efficiency**

	n <sub>1</sub> [min <sup>-1</sup> ]	Rendimento Efficiency	Rapporto / Ratio											
			5	7.5	10	15	20	25	30	40	50	60	80	100
CM026	2800	Rd	89	87	85	83	80		73	68	64	60		
	1400		87	84	83	78	74		66	61	57	53		
	900		84	83	80	75	71		61	57	52	48		
			Rs	72	71	68	61	56		46	41	36	34	
CM030	2800	Rd	89	88	86	84	81	78	74	70	65	62	57	52
	1400		86	85	84	79	75	72	67	62	58	55	48	43
	900		84	83	81	75	71	68	62	58	53	49	43	39
			Rs	72	67	63	55	50	43	39	35	31	27	23
CM040	2800	Rd	90	89	87	84	83	80	77	73	69	66	60	56
	1400		88	86	84	81	78	74	70	65	60	58	52	46
	900		86	84	82	77	74	70	66	60	57	53	46	41
			Rs	74	71	67	60	55	51	45	40	36	32	28
CM050	2800	Rd	91	90	88	86	84	82	78	74	71	68	62	58
	1400		89	87	85	82	79	76	72	67	63	60	54	49
	900		87	85	84	79	75	72	68	62	59	55	48	43
			Rs	73	70	66	59	55	51	44	39	35	32	27
CM063	2800	Rd	91	90	88	86	84	83	79	76	73	70	65	60
	1400		90	88	86	84	81	78	75	70	66	63	57	52
	900		89	86	84	81	78	75	70	65	61	58	52	47
			Rs	73	71	67	60	55	51	45	40	36	33	28
CM070	2800	Rd		90	89	87	85	84	80	77	74	72	67	62
	1400			89	87	84	82	80	76	72	68	65	60	53
	900			87	85	82	79	77	72	67	63	60	54	49
			Rs		72	69	62	60	55	48	43	38	36	31



**Rendimento teorico del riduttore dopo il rodaggio**  
*Theoretical efficiency of the gearbox after the first running period*





Dati tecnici per servizio S2

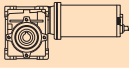
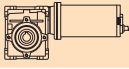
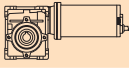
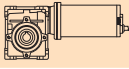

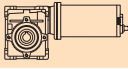
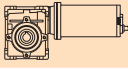
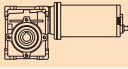
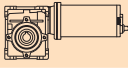
Technical data for S2 duty

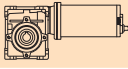
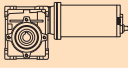
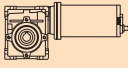
P <sub>1</sub> [W]	n <sub>2</sub> [min <sup>-1</sup> ]	M <sub>2</sub> [Nm]	sf	i		Versione motore Motor version	
<b>100</b>							
(3000 min <sup>-1</sup> )	<b>600</b>	1.4	7.1	5		ECM070/026 12E/24E	
	<b>400</b>	2.1	5.3	7.5		120.66/240.66	
	<b>300</b>	2.7	4.1	10			
	<b>200</b>	4.0	2.8	15			
	<b>150</b>	5.1	2.2	20			
	<b>100</b>	7.0	1.7	30			
	<b>75</b>	8.7	1.3	40			
	<b>60</b>	10	1.0	50			
	<b>50</b>	11	0.8	60			
	<b>150</b>	5.2	2.7	20			ECM070/030 12E/24E
	<b>120</b>	6.2	2.4	25	120.66/240.66		
	<b>100</b>	7.1	2.5	30			
	<b>75</b>	8.9	1.8	40			
	<b>60</b>	10	1.4	50			
	<b>50</b>	12	1.2	60			
	<b>38</b>	15	0.8	80			
	<b>30</b>	17	0.7	100			
	<b>50</b>	13	2.3	60			ECM070/040 12E/24E
	<b>38</b>	15	1.8	80			120.66/240.66
	<b>30</b>	18	1.4	100			
	<b>30</b>	18	1.4	100			

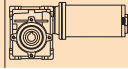
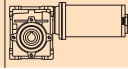
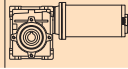
P <sub>1</sub> [W]	n <sub>2</sub> [min <sup>-1</sup> ]	M <sub>2</sub> [Nm]	sf	i		Versione motore Motor version
<b>140</b>						
(3000 min <sup>-1</sup> )	<b>600</b>	2.0	5.0	5		ECM100/026 120/240/24E
	<b>400</b>	2.9	3.8	7.5		120.66/240.66
	<b>300</b>	3.8	2.9	10		
	<b>200</b>	5.5	2.0	15		
	<b>150</b>	7.1	1.5	20		
	<b>100</b>	10	1.2	30		
	<b>75</b>	12	0.9	40		
	<b>60</b>	14	0.7	50		
	<b>50</b>	13	0.7	60		
	<b>200</b>	5.6	2.8	15		
	<b>150</b>	7.2	1.9	20	120.66/240.66	
	<b>120</b>	8.7	1.7	25		
	<b>100</b>	10	1.8	30		
	<b>75</b>	12	1.3	40		
	<b>60</b>	14	1.0	50		
	<b>50</b>	17	0.8	60		
	<b>38</b>	17	0.7	80		
	<b>30</b>	16	0.7	100		
	<b>100</b>	10	3.7	30		
	<b>75</b>	13	2.6	40		24E
	<b>60</b>	15	2.1	50		120.66/240.66
	<b>50</b>	18	1.6	60		
	<b>38</b>	21	1.3	80		
	<b>30</b>	25	1.0	100		
	<b>30</b>	25	1.0	100		

P <sub>1</sub> [W]	n <sub>2</sub> [min <sup>-1</sup> ]	M <sub>2</sub> [Nm]	sf	i		Versione motore Motor version
<b>250</b>						
(3000 min <sup>-1</sup> )	<b>600</b>	3.5	2.8	5		ECM180/026 120/240
	<b>400</b>	5.2	2.1	7.5		120.66/240.66
	<b>300</b>	6.8	1.6	10		
	<b>200</b>	10	1.1	15		
	<b>150</b>	13	0.9	20		
	<b>100</b>	17	0.7	30		
	<b>75</b>	16	0.7	40		
	<b>60</b>	14	0.7	50		
	<b>50</b>	13	0.7	60		
	<b>600</b>	3.5	3.7	5		
	<b>400</b>	5.3	2.9	7.5	120.66/240.66	
	<b>300</b>	6.8	2.3	10		
	<b>200</b>	10	1.6	15		
	<b>150</b>	13	1.1	20		
	<b>120</b>	16	1.0	25		
	<b>100</b>	18	1.0	30		
	<b>75</b>	22	0.7	40		
	<b>60</b>	21	0.7	50		
	<b>50</b>	20	0.7	60		
	<b>38</b>	17	0.7	80		
	<b>30</b>	16	0.7	100		
	<b>30</b>	16	0.7	100		

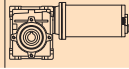
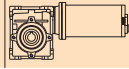
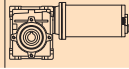
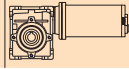
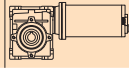
P <sub>1</sub> [W]	n <sub>2</sub> [min <sup>-1</sup> ]	M <sub>2</sub> [Nm]	sf	i		Versione motore Motor version
<b>250</b>						
(3000 min <sup>-1</sup> )	<b>200</b>	10	3.5	15		ECM180/040 120/240*
	<b>150</b>	13	2.3	20		24E
	<b>120</b>	16	1.8	25		120.66/240.66
	<b>100</b>	18	2.1	30		
	<b>75</b>	23	1.5	40		
	<b>60</b>	27	1.2	50		
	<b>50</b>	32	0.9	60		
	<b>38</b>	38	0.7	80		
	<b>30</b>	34	0.7	100		
	<b>75</b>	24	2.5	40		
	<b>60</b>	28	2.0	50	IEC 63B14	
	<b>50</b>	32	1.6	60		
	<b>38</b>	39	1.2	80	Solo / Only	
	<b>30</b>	46	0.9	100		
	<b>30</b>	46	0.9	100		
	<b>30</b>	46	0.9	100		

P <sub>1</sub> [W]	n <sub>2</sub> [min <sup>-1</sup> ]	M <sub>2</sub> [Nm]	sf	i		Versione motore Motor version
<b>350</b>						
(3000 min <sup>-1</sup> )	<b>600</b>	5.0	2.6	5		ECM250/030 120/240
	<b>400</b>	7.4	2.0	7.5		120.66/240.66
	<b>300</b>	10	1.7	10		
	<b>200</b>	14	1.1	15		
	<b>150</b>	18	0.8	20		
	<b>120</b>	22	0.7	25		
	<b>100</b>	25	0.7	30		
	<b>75</b>	22	0.7	40		
	<b>60</b>	21	0.7	50		
	<b>200</b>	14	2.5	15		
	<b>150</b>	18	1.7	20	120.66/240.66	
	<b>120</b>	22	1.3	25		
	<b>100</b>	26	1.5	30		
	<b>75</b>	33	1.0	40		
	<b>60</b>	38	0.8	50		
	<b>50</b>	44	0.7	60		
	<b>38</b>	38	0.7	80		
	<b>30</b>	35	0.7	100		
	<b>150</b>	19	2.9	20		
	<b>120</b>	23	2.2	25		120.66/240.66
	<b>100</b>	26	2.6	30		
	<b>75</b>	33	1.8	40		
	<b>60</b>	40	1.4	50		
	<b>50</b>	45	1.1	60		
	<b>38</b>	55	0.8	80		
	<b>30</b>	65	0.7	100		
	<b>75</b>	34	3.3	40		ECM250/063 120/240
	<b>60</b>	41	2.5	50		IEC 71B14
	<b>50</b>	47	2.1	60		
	<b>38</b>	58	1.5	80		Solo / Only
	<b>30</b>	67	1.2	100		
	<b>30</b>	67	1.2	100		
	<b>30</b>	67	1.2	100		

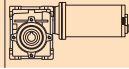
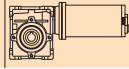
P <sub>1</sub> [W]	n <sub>2</sub> [min <sup>-1</sup> ]	M <sub>2</sub> [Nm]	sf	i		Versione motore Motor version
<b>500</b>						
(3000 min <sup>-1</sup> )	<b>600</b>	7.1	1.8	5		ECM350/030 120/240
	<b>400</b>	11	1.4	7.5		120.66/240.66
	<b>300</b>	14	1.2	10		
	<b>200</b>	20	0.8	15		
	<b>150</b>	20	0.7	20		
	<b>120</b>	21	0.7	25		
	<b>100</b>	26	0.7	30		
	<b>75</b>	23	0.7	40		
	<b>60</b>	21	0.7	50		
	<b>60</b>	21	0.7	50		
	<b>60</b>	21	0.7	50		

N.B.  
Verificare sempre che la coppia M<sub>2</sub> utilizzata non ecceda il valore indicato nelle caselle in grigio  
N.B.  
Please check that the output torque M<sub>2</sub> does not exceed the value in the grey areas

NOTA: per servizio continuo o altamente intermittente, contattare il servizio tecnico



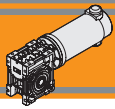

NOTE: for continuous or highly intermittent duty, please contact our technical service

\*: Motore inclinato con portaspazzole a 45°  
Motor assembly with brush holder inclined 45°

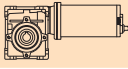
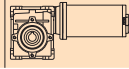
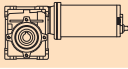
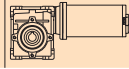
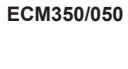
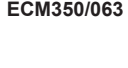

**Dati tecnici per servizio S2**

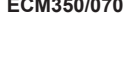
**Technical data for S2 duty**

P <sub>1</sub> [W]	n <sub>2</sub> [min <sup>-1</sup> ]	M <sub>2</sub> [Nm]	sf	i		Versione motore Motor version	P <sub>1</sub> [W]	n <sub>2</sub> [min <sup>-1</sup> ]	M <sub>2</sub> [Nm]	sf	i		Versione motore Motor version		
<b>500</b>							<b>800</b>								
(3000 min <sup>-1</sup> )	<b>600</b>	7.2	4.0	5		ECM350/040	120/240	(3000 min <sup>-1</sup> )	<b>600</b>	11	2.5	5		ECM600/040	120/240
	<b>400</b>	11	2.9	7.5		120.66/240.66		<b>400</b>	17	1.8	7.5	120.66/240.66			
	<b>300</b>	14	2.4	10				<b>300</b>	22	1.5	10				
	<b>200</b>	20	1.7	15				<b>200</b>	32	1.1	15				
	<b>150</b>	26	1.2	20				<b>150</b>	42	0.7	20				
	<b>120</b>	32	0.9	25				<b>120</b>	40	0.7	25				
	<b>100</b>	37	1.0	30				<b>100</b>	54	0.7	30				
	<b>75</b>	46	0.7	40				<b>75</b>	49	0.7	40				
	<b>60</b>	46	0.7	50				<b>600/050</b>	12	4.7	5	120/240			
	<b>50</b>	41	0.7	60				<b>400</b>	17	3.3	7.5	120.66/240.66			
	<b>38</b>	39	0.7	80			<b>300</b>	22	2.7	10					
	<b>30</b>	34	0.7	100			<b>200</b>	33	1.9	15					
	<b>200</b>	21	3.0	15		ECM350/050	120/240	<b>150</b>	43	1.3	20				
	<b>150</b>	27	2.1	20		120.66/240.66		<b>120</b>	52	1.0	25				
	<b>120</b>	33	1.6	25				<b>100</b>	60	1.1	30				
	<b>100</b>	37	1.8	30				<b>75</b>	75	0.8	40				
	<b>75</b>	47	1.3	40				<b>60</b>	81	0.7	50				
	<b>60</b>	57	1.0	50				<b>50</b>	74	0.7	60				
	<b>50</b>	65	0.8	60				<b>38</b>	66	0.7	80				
	<b>38</b>	66	0.7	80				<b>200</b>	33	3.5	15	120/240			
	<b>30</b>	61	0.7	100				<b>150</b>	43	2.4	20	120.66/240.66			
	<b>75</b>	48	2.3	40			ECM350/063	120/240	<b>120</b>	53	1.8	25			
	<b>60</b>	58	1.8	50	IEC 71B14			<b>100</b>	60	2.1	30				
	<b>50</b>	67	1.5	60				<b>75</b>	77	1.4	40				
	<b>38</b>	83	1.1	80	Solo / Only			<b>60</b>	93	1.1	50				
	<b>30</b>	96	0.8	100				<b>50</b>	107	0.9	60				
	<b>60</b>	59	2.5	50		ECM350/070	120/240	<b>38</b>	132	0.7	80				
	<b>50</b>	69	2.1	60		IEC 71B5		<b>30</b>	114	0.7	100				
	<b>38</b>	85	1.5	80				<b>120</b>	53	2.6	25	120/240			
	<b>30</b>	99	1.2	100		Solo / Only		<b>100</b>	61	3.0	30	IEC 71B5			
								<b>75</b>	78	2.1	40				
							<b>60</b>	94	1.6	50					
							<b>50</b>	110	1.3	60					
							<b>38</b>	137	0.9	80					
							<b>30</b>	158	0.7	100					

N.B.  
Verificare sempre che la coppia M<sub>2</sub> utilizzata non ecceda il valore indicato nelle caselle in grigio  
N.B.  
Please check that the output torque M<sub>2</sub> does not exceed the value in the grey areas

**NOTA:** per servizio continuo o altamente intermittente, contattare il servizio tecnico

**NOTE:** for continuous or highly intermittent duty, please contact our technical service

**Motori applicabili**

**Motor adapters**

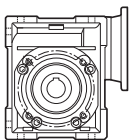
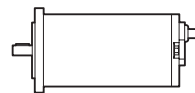

		EC						
		070.12E 070.24E	100.120 100.240 100.24E	180.120 180.240	180.24E	250.120 250.240	350.120 350.240	600.120 600.240
<b>CM</b>	<b>026</b>	5-60	5-60	5-60				
	<b>030</b>	5-100	5-100	5-100	5-50	5-50	5-50	
	<b>040</b>		5-100	5-100	5-100	5-100	5-100	5-40
	<b>050</b>			40-100 <sup>(1)</sup>	5-100	5-100	15-100	5-80
	<b>063</b>					40-100 <sup>(2)</sup>	40-100 <sup>(2)</sup>	15-100
	<b>070</b>						50-100 <sup>(3)</sup>	25-100 <sup>(3)</sup>

5-100

Rapporti di riduzione i  
Ratio i

(1): Solo IEC 63 B14  
63 B14 only

(2): Solo IEC 71 B14  
71 B14 only

(3): Solo IEC 71 B5  
71 B5 only

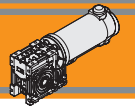

Dimensioni

Dimensions

ECM070/026 U

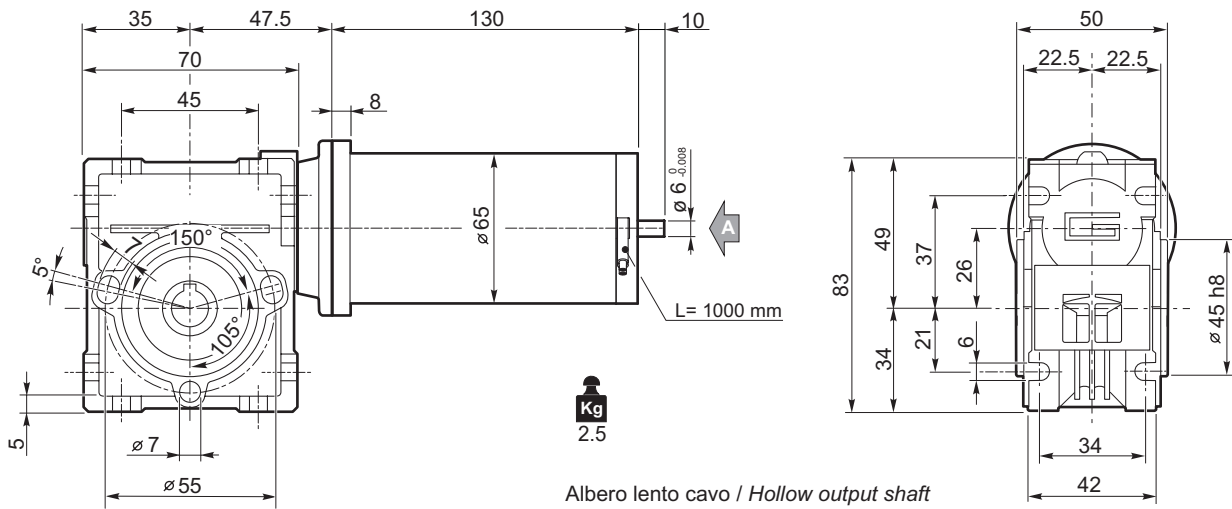

**Kg**  
2.5

Albero lento cavo / Hollow output shaft

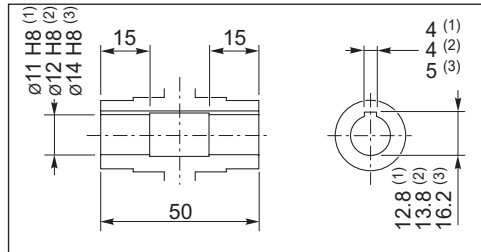

- (1): ECM 070/026 (D11)
- (2): ECM 070/026
- (3): ECM 070/026 (D14)

Vista da A  
View from A

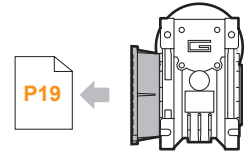
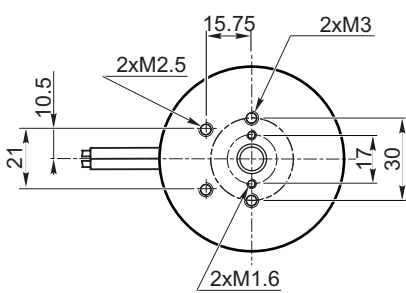

ECM070/026 F...

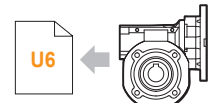

CL026

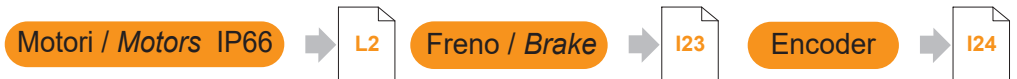

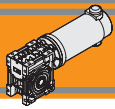

## Dimensioni

## Dimensions

### ECM070/030 U

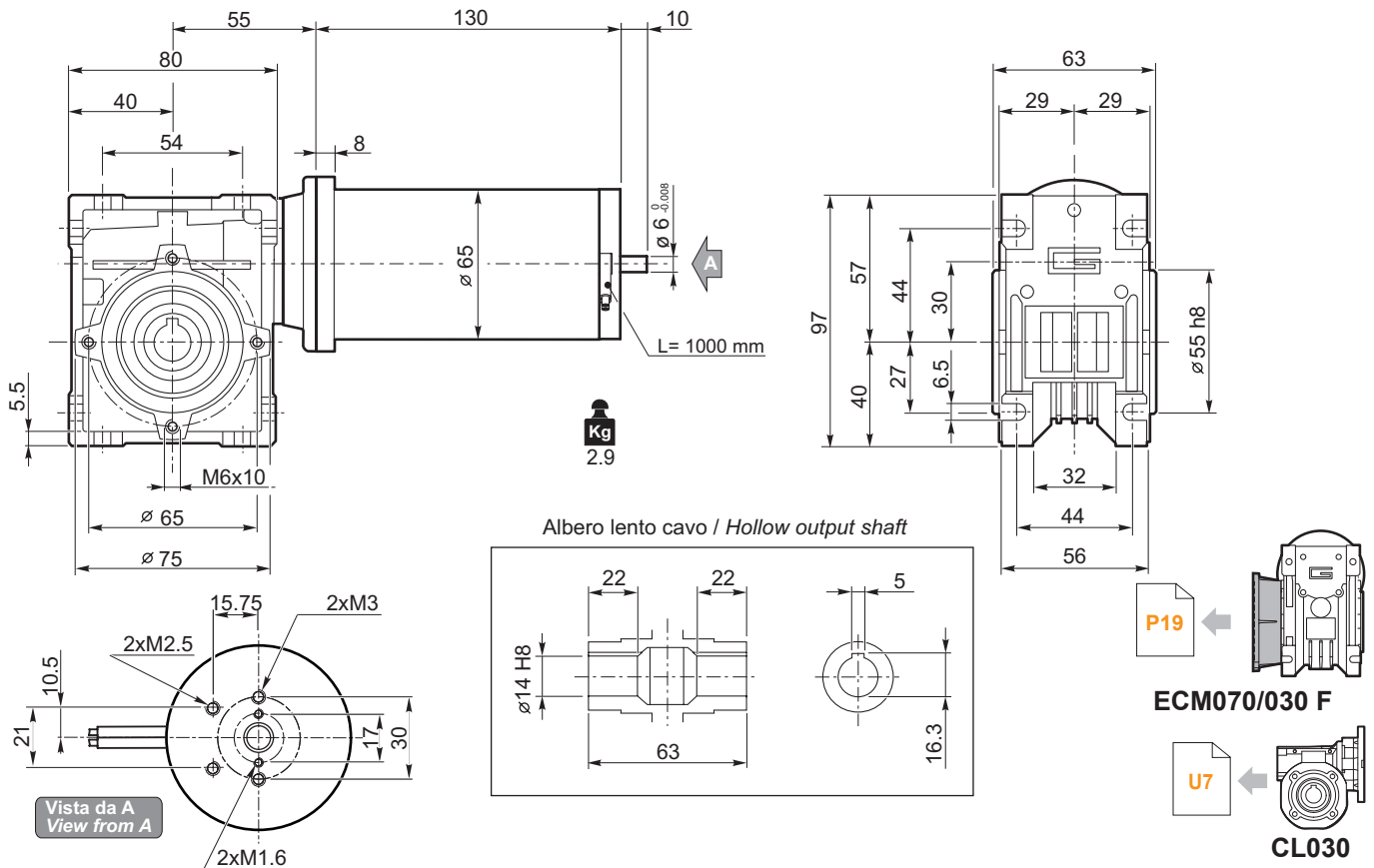

Motori / Motors IP66



Freno / Brake



Encoder



### ECM100/026 U

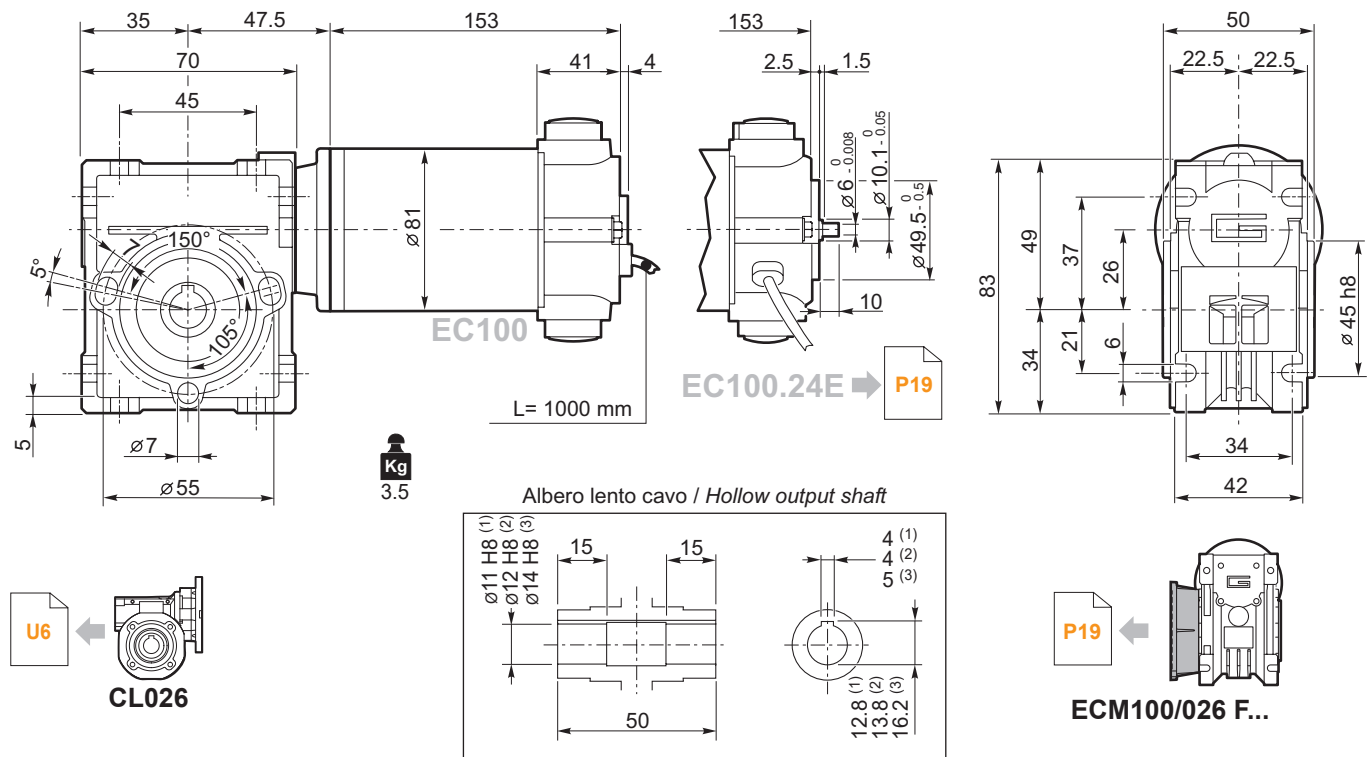

Motori / Motors IP66



Freno / Brake



Encoder



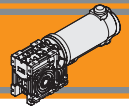

Dimensioni

Dimensions

ECM100/030 U

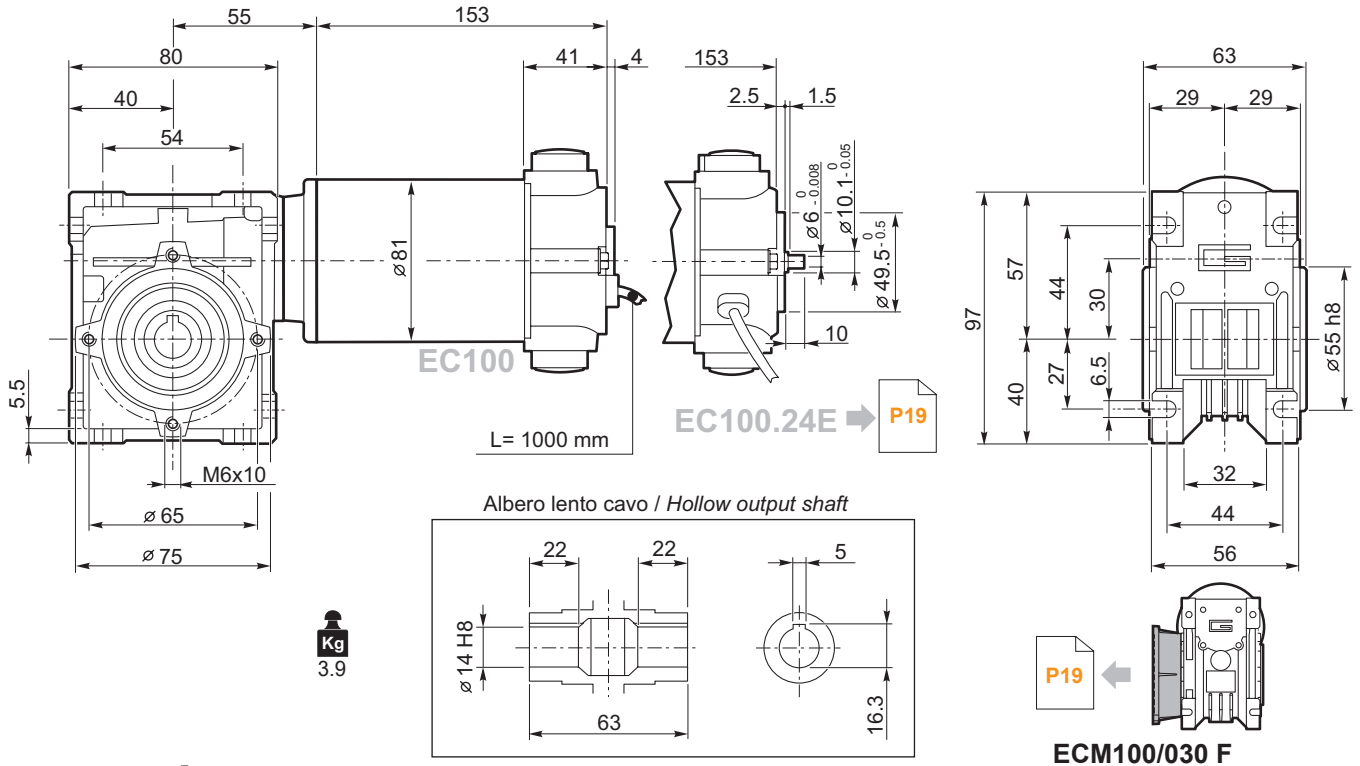

ECM100/040 U

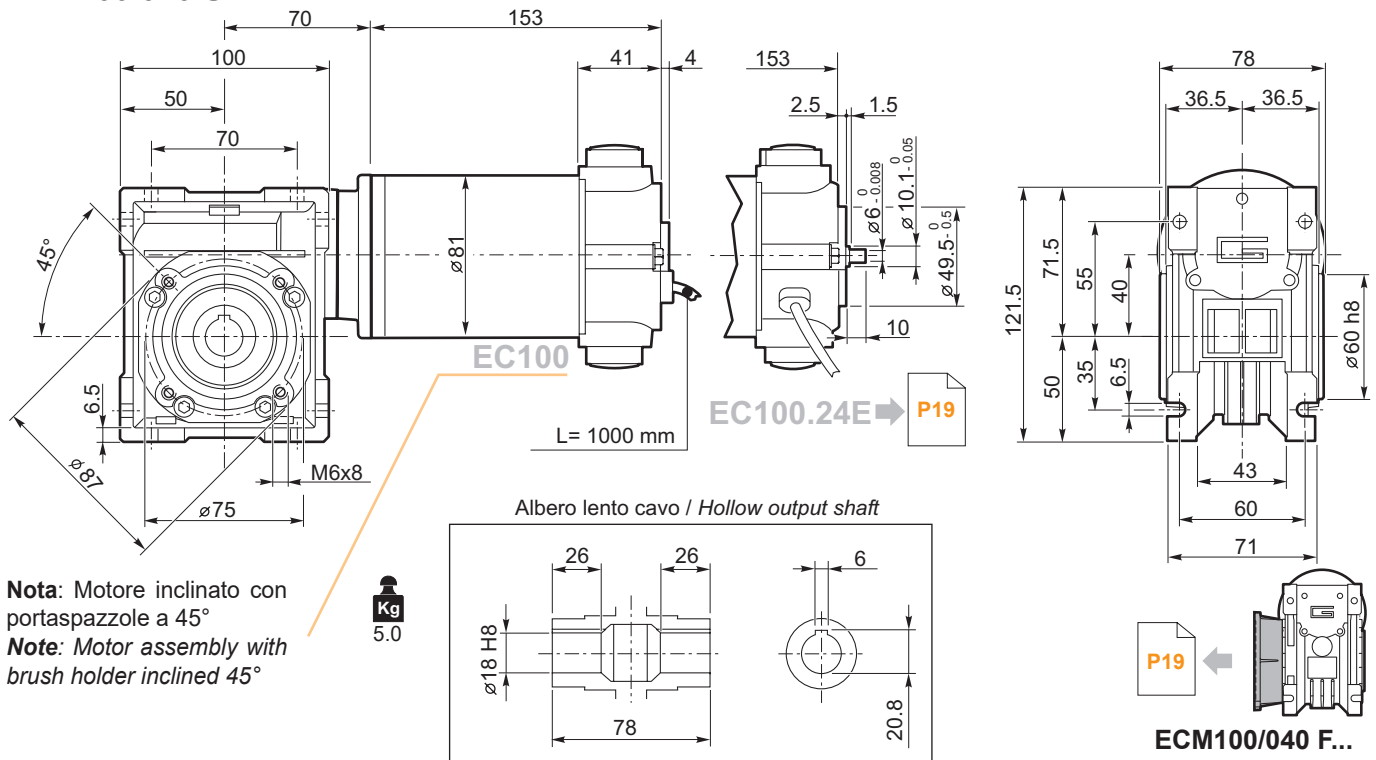

**Nota:** Motore inclinato con portaspazzole a 45°  
**Note:** Motor assembly with brush holder inclined 45°

ECM

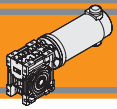

## Dimensioni

## Dimensions

### ECM180/026 U

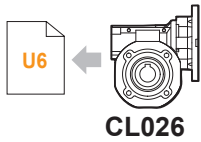
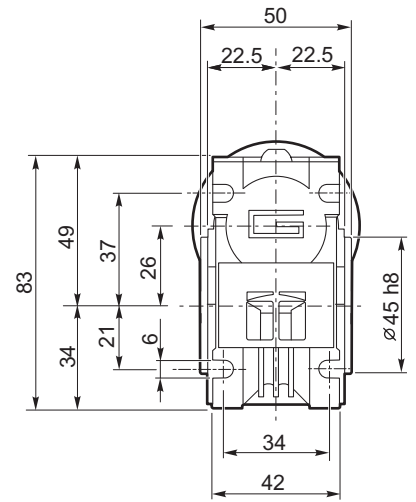
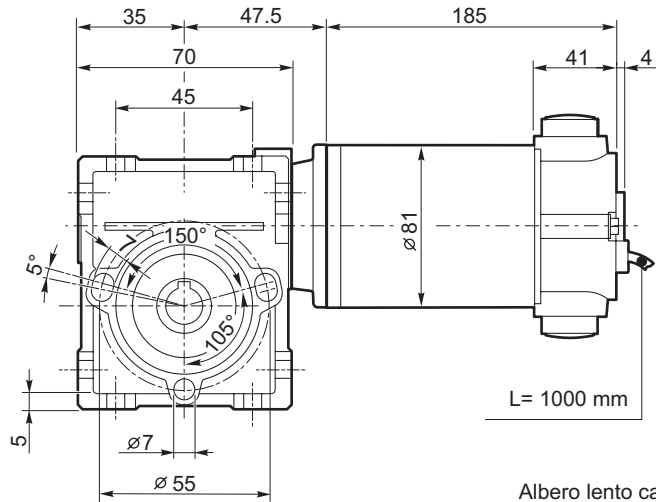

**Kg**  
4.2

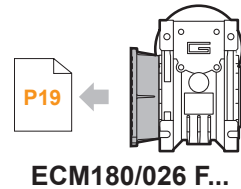
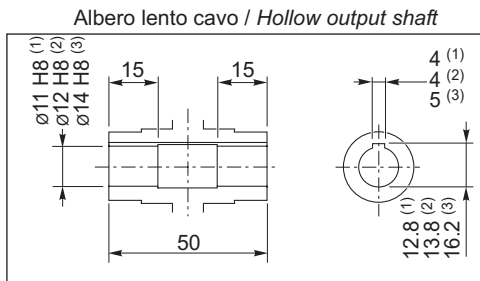

**Motori / Motors IP66**

**L6**

- (1): ECM 070/026 (D11)
- (2): ECM 070/026
- (3): ECM 070/026 (D14)

**Freno / Brake**

**I23**

**Encoder**

**I24**

### ECM180/030 U

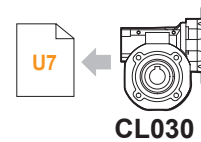
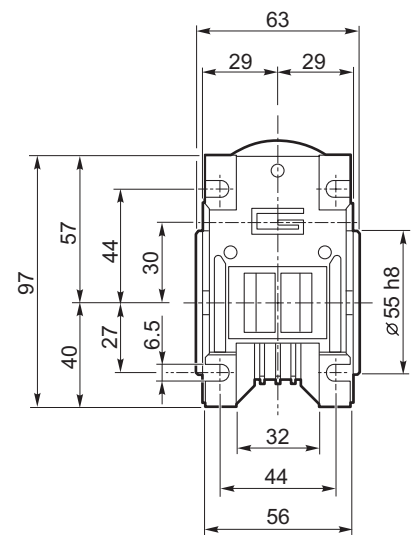
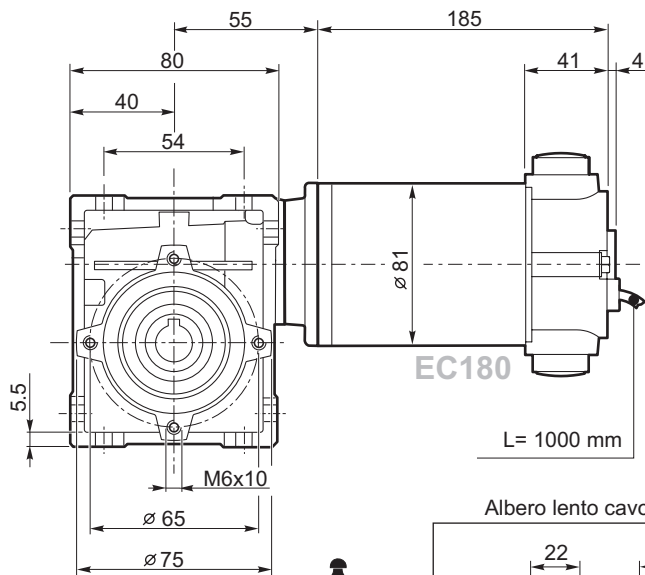

**Kg**  
4.6

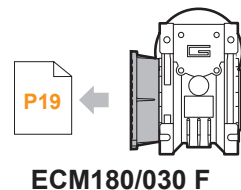
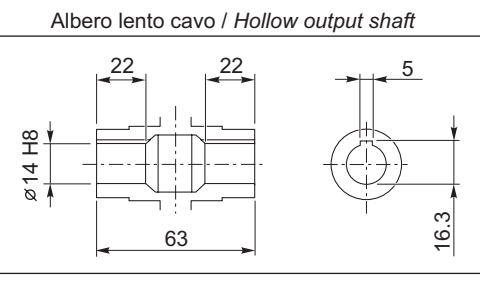

**Motori / Motors IP66**

**L6**

**Freno / Brake**

**I23**

**Encoder**

**I24**

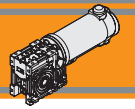

Dimensioni

Dimensions

ECM180/040 U

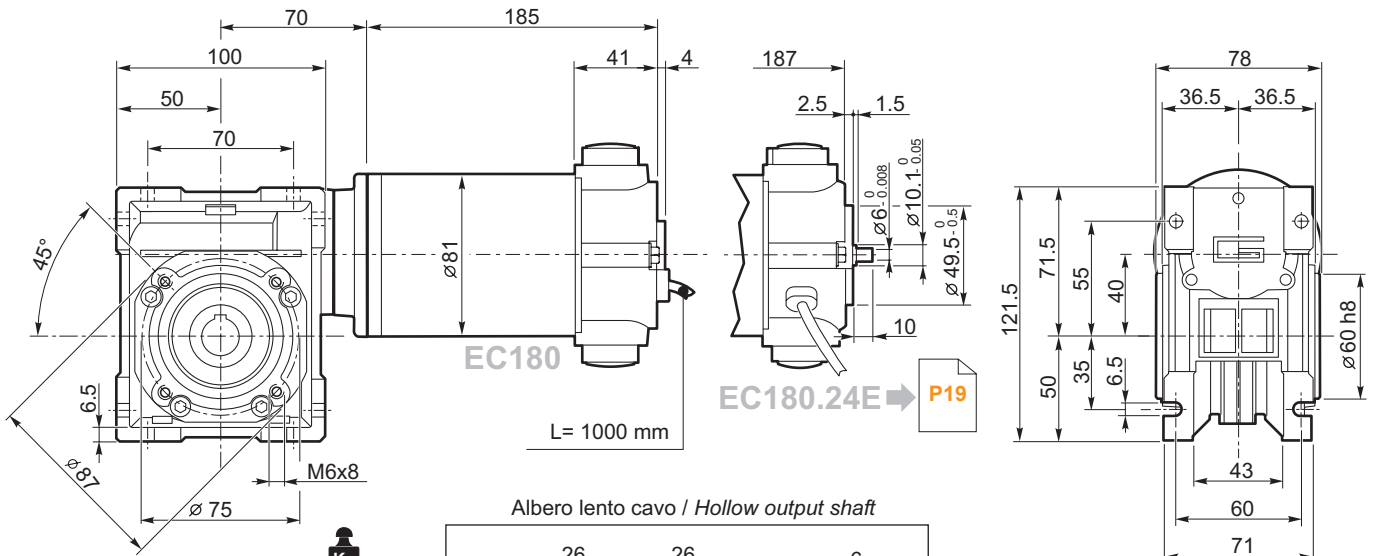

**Nota:** Motore inclinato con portaspazzole a 45°  
**Note:** Motor assembly with brush holder inclined 45°

**Kg**  
5.7

Albero lento cavo / Hollow output shaft

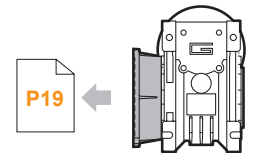
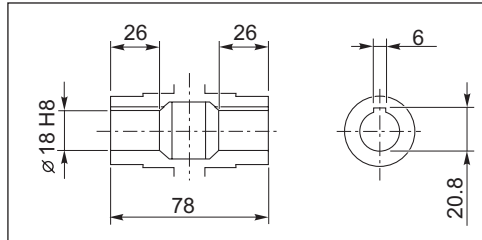

ECM180/040 F..

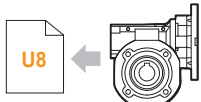

CL040

Motori / Motors IP66 → 16

Freno / Brake → 123

Encoder → 124

ECM180/050 U

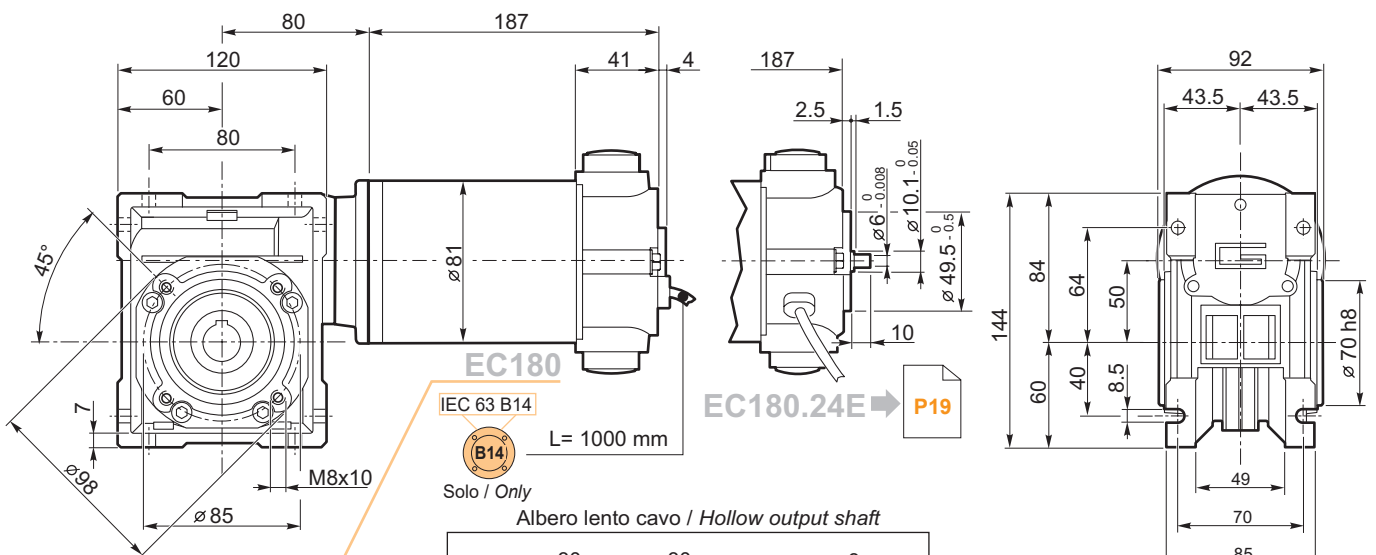

**Nota:** Motore inclinato con portaspazzole a 45°  
**Note:** Motor assembly with brush holder inclined 45°

**Kg**  
6.9

IEC 63 B14



Solo / Only

Albero lento cavo / Hollow output shaft

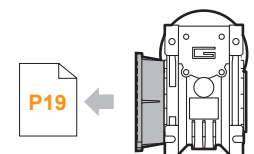
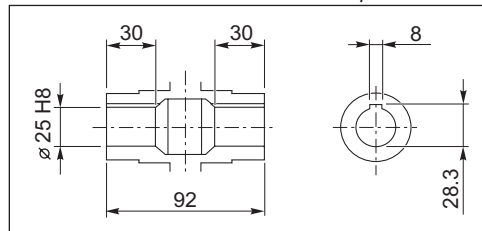

ECM180/050 F..

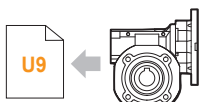

CL050

Freno / Brake → 123

Encoder → 124

ECM

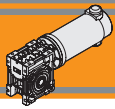

## Dimensioni

## Dimensions

### ECM250/030 U

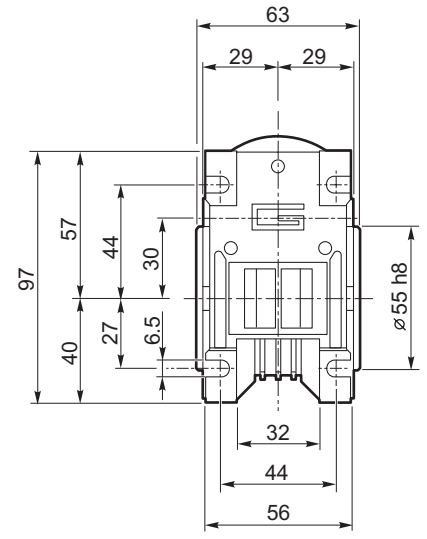
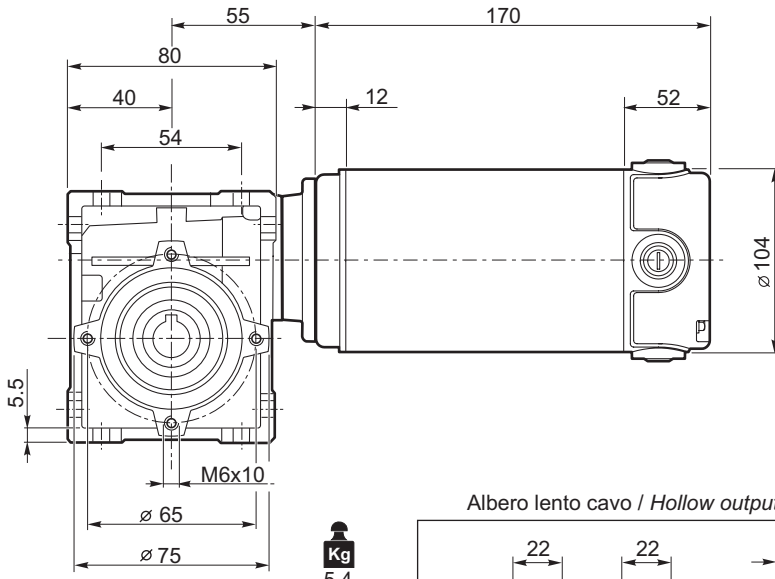

Albero lento cavo / Hollow output shaft

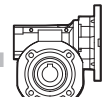
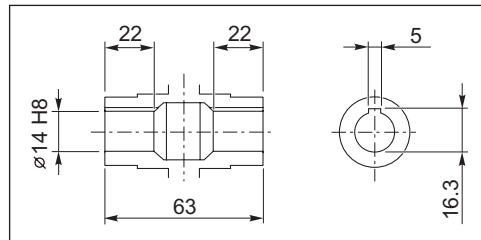

CL030

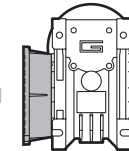

ECM250/030 F

Motori / Motors IP66

H8

### ECM250/040 U

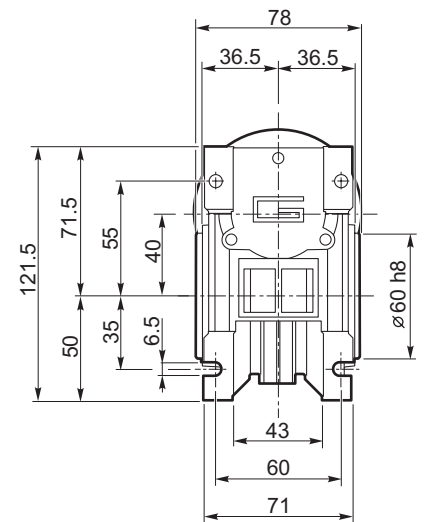
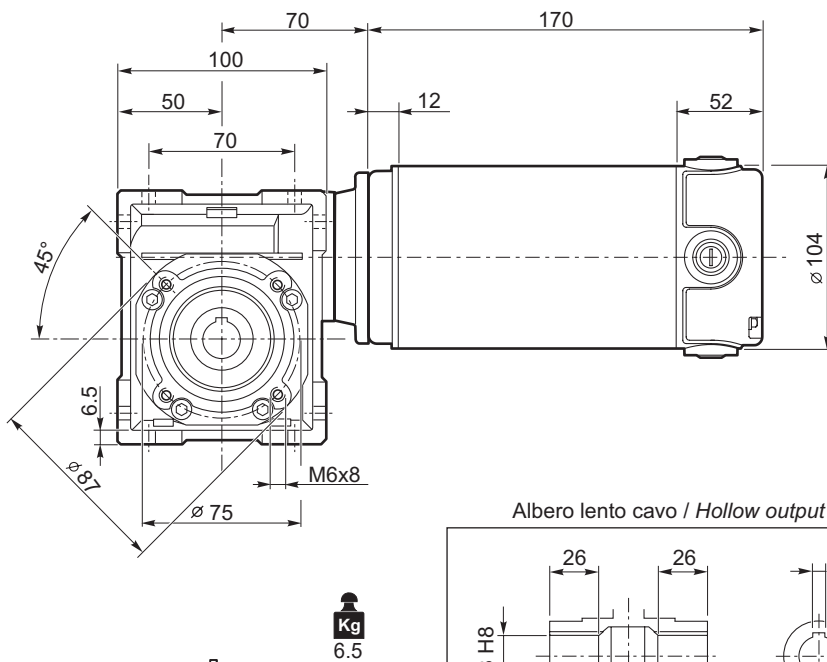

Albero lento cavo / Hollow output shaft

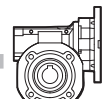
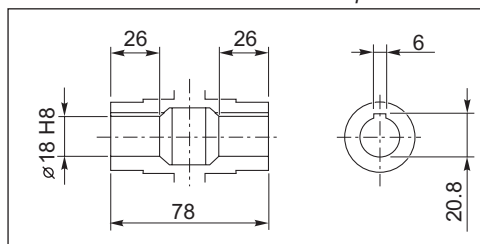

CL040

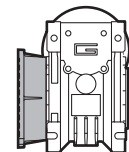

ECM250/040 F..

Motori / Motors IP66

L8



Dimensioni

Dimensions

ECM250/050 U

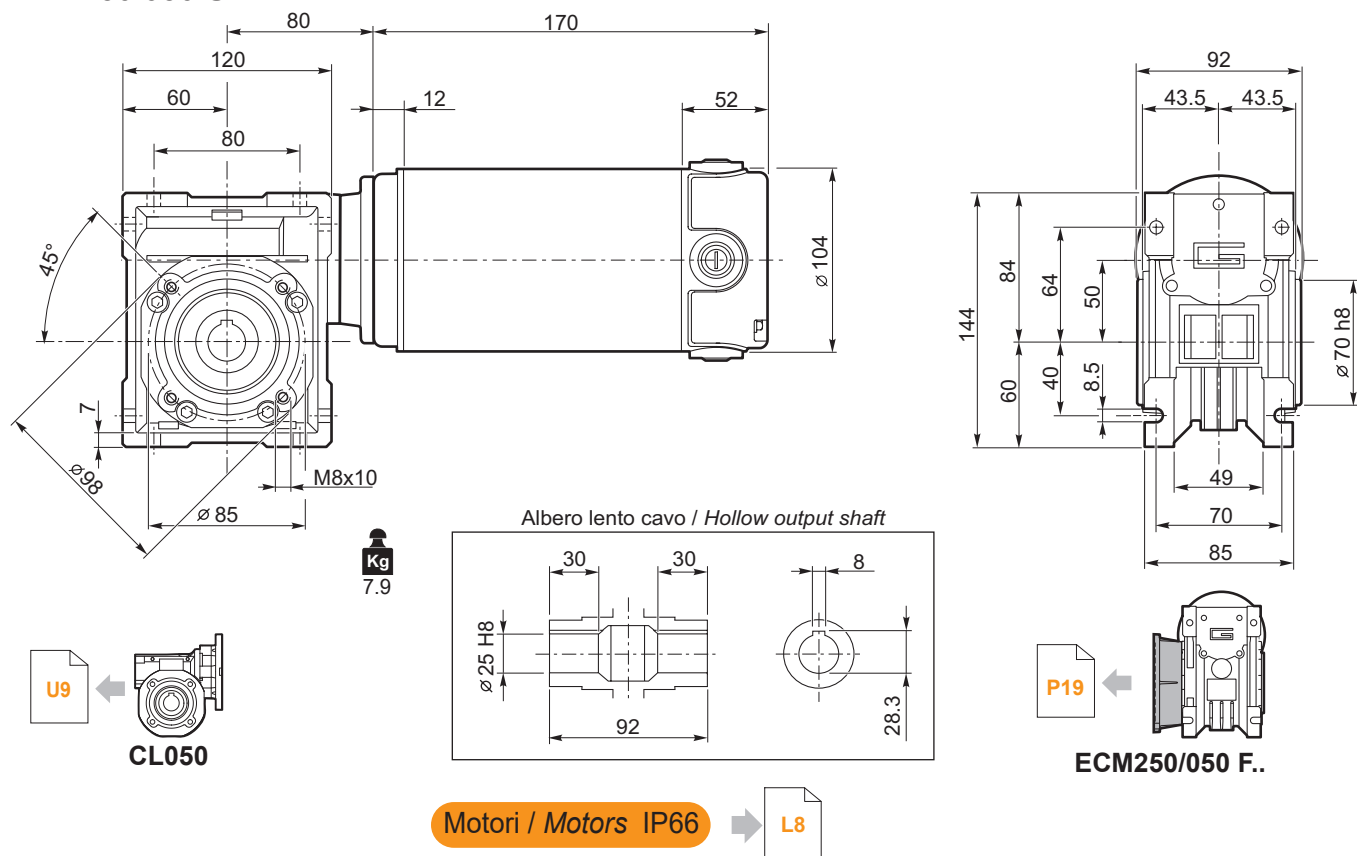

ECM250/063 U

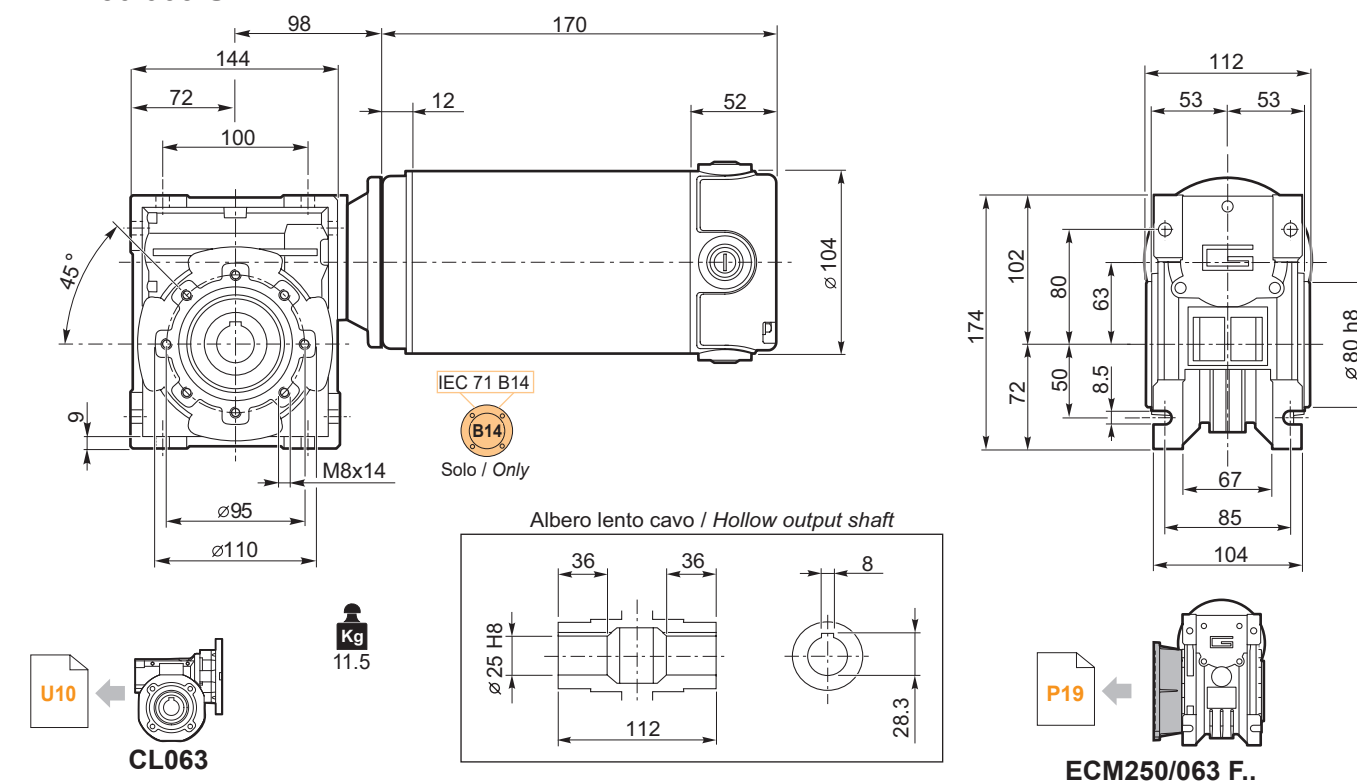

ECM

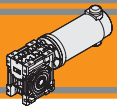

## Dimensioni

## Dimensions

### ECM350/030 U

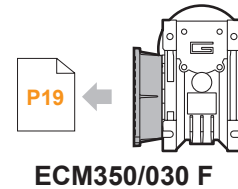
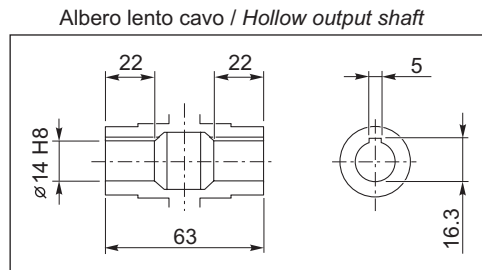
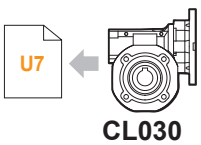
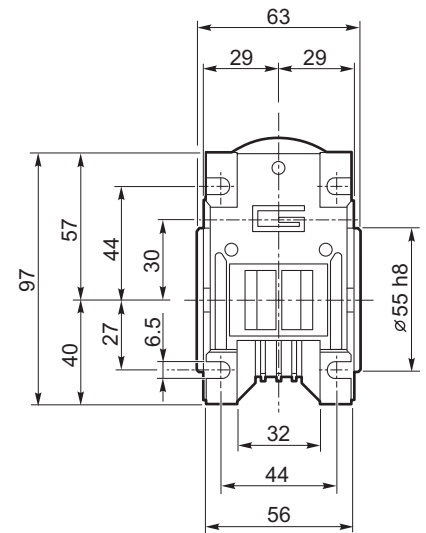
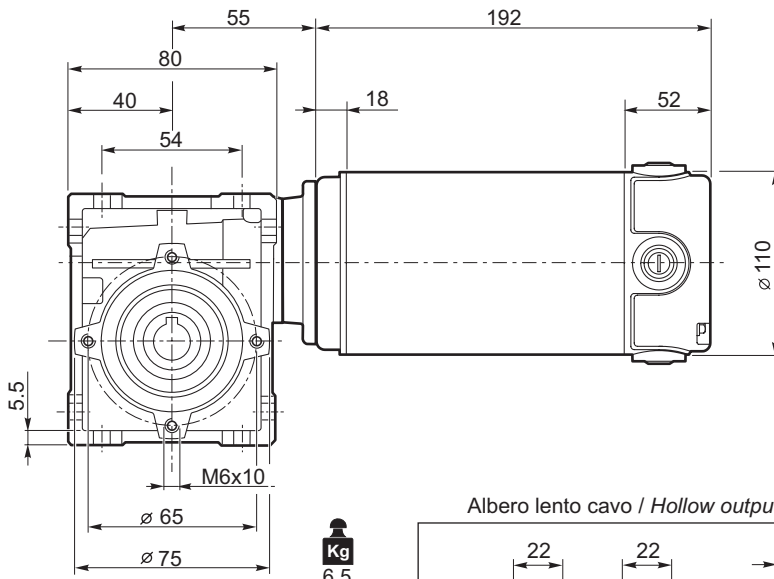

Motori / Motors IP66

L10

Freno / Brake

I23

### ECM350/040 U

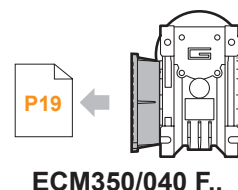
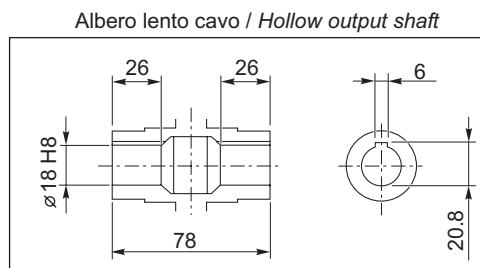
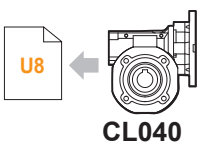
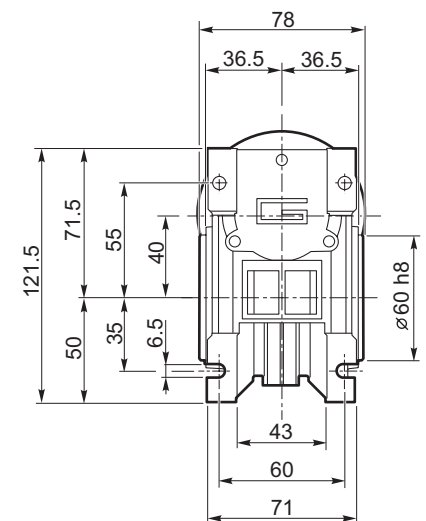
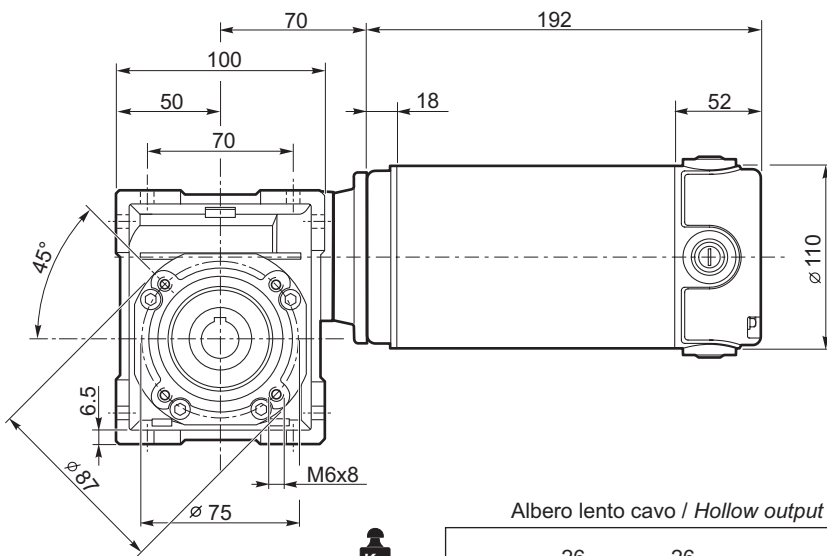

Motori / Motors IP66

L10

Freno / Brake

I23



Dimensioni

Dimensions

ECM350/050 U

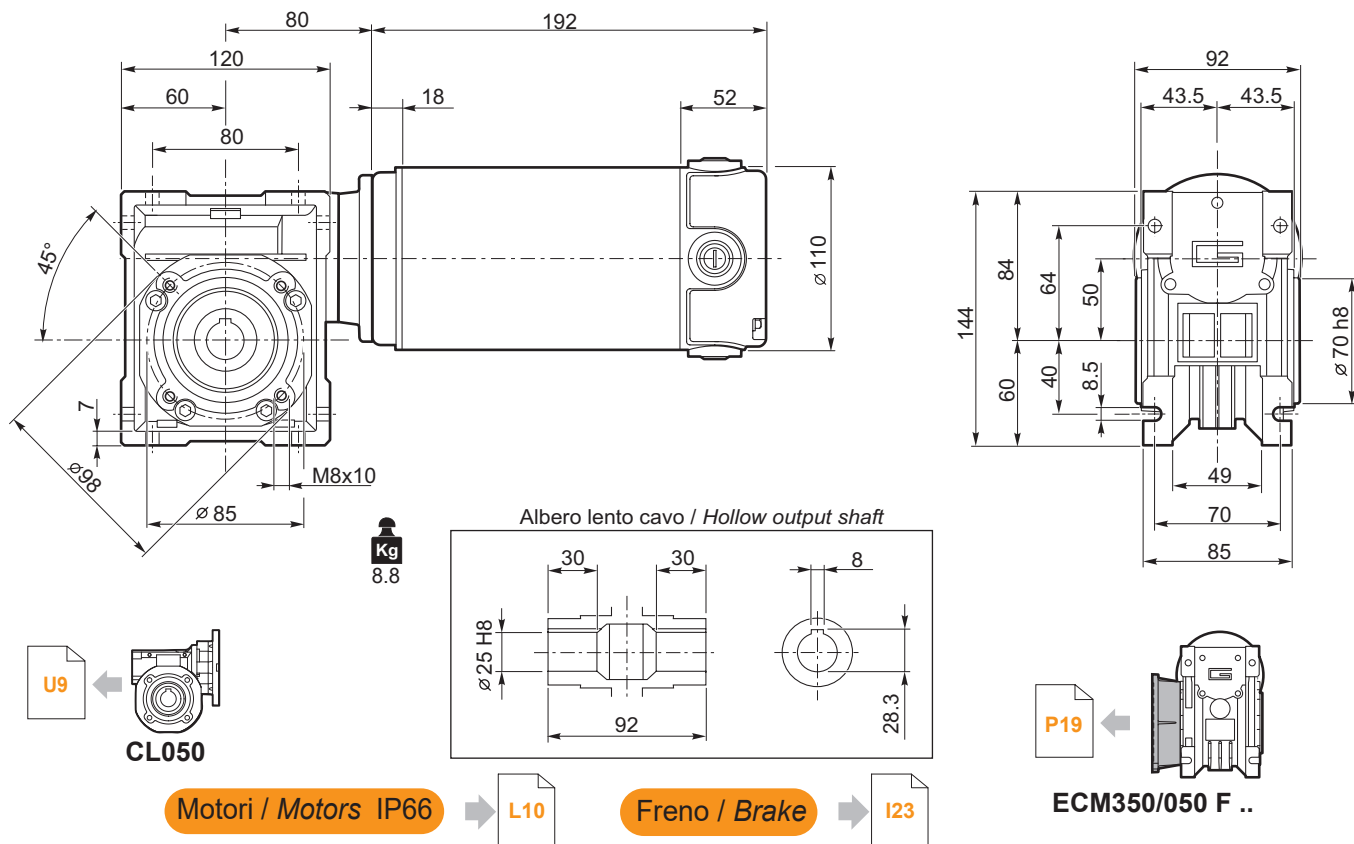

ECM350/063 U

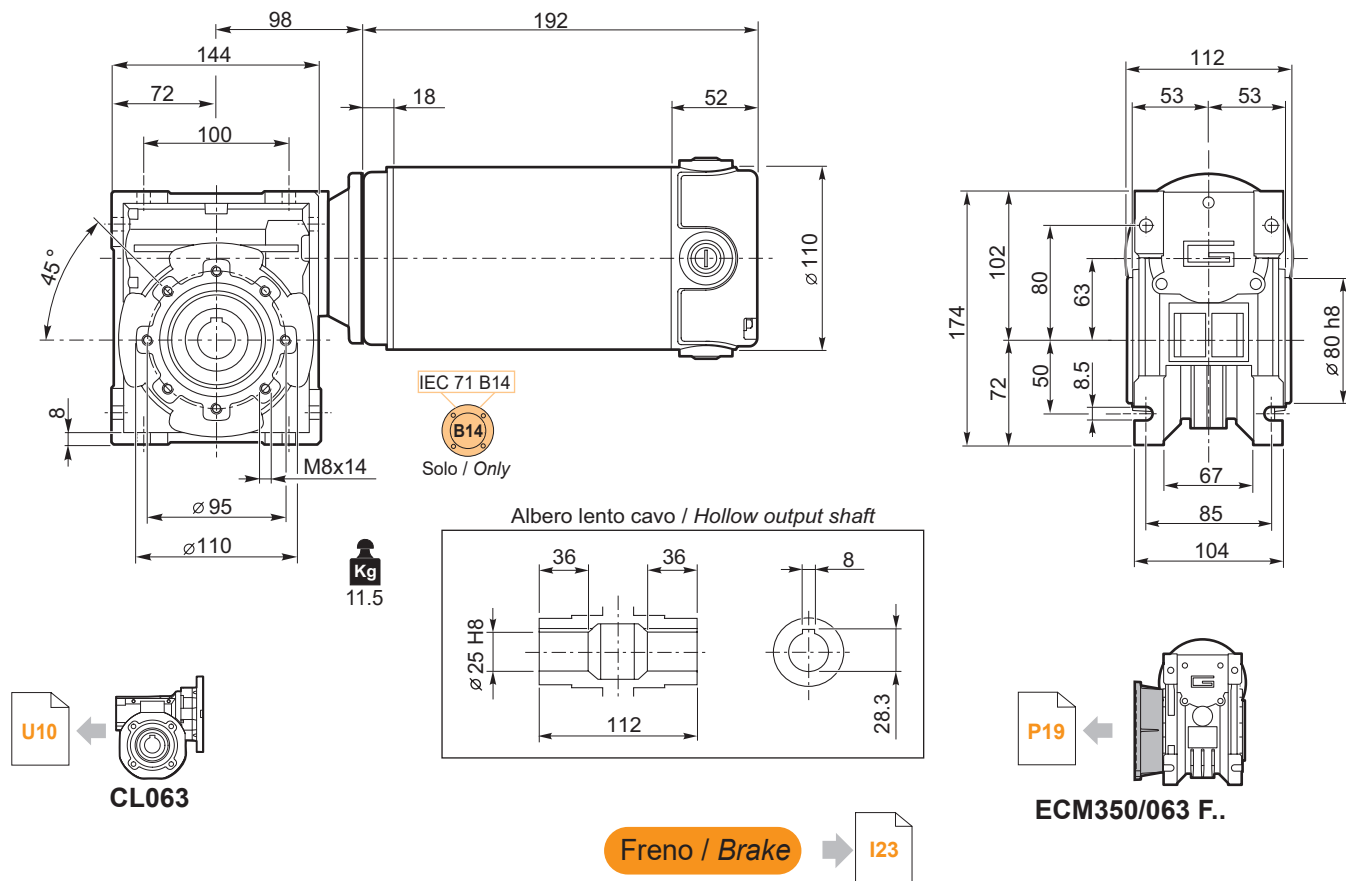

ECM

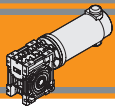

**Dimensioni**

**Dimensions**

**ECM350/070 U**

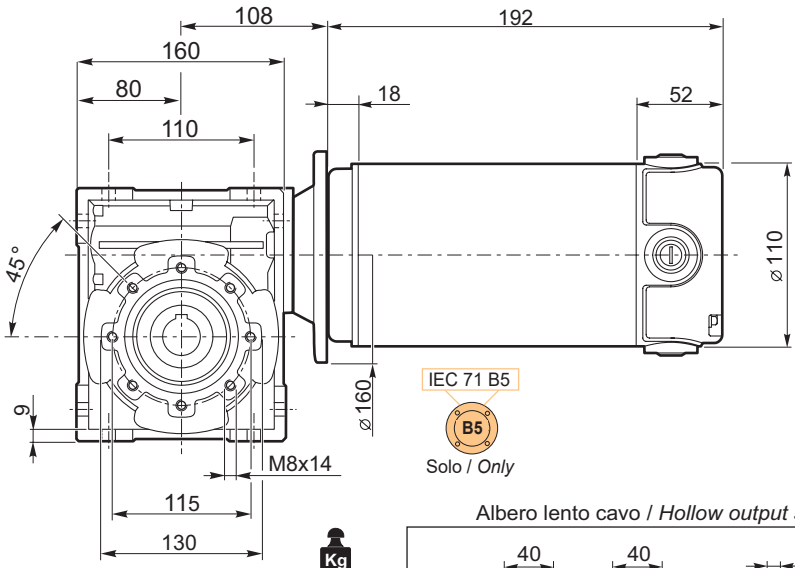

IEC 71 B5  
  
 Solo / Only

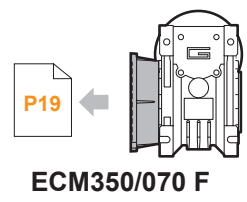
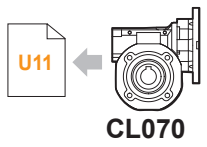
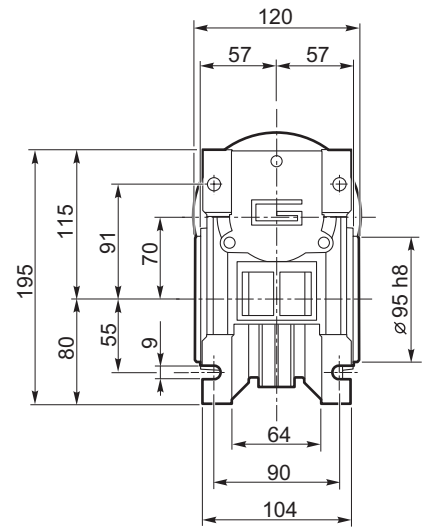
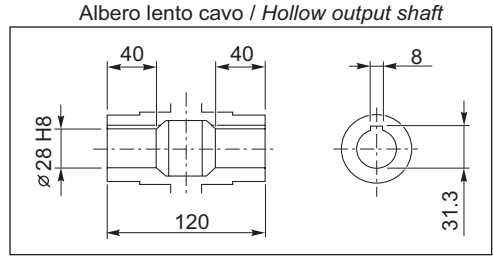



Dimensioni

Dimensions

ECM600/040 U

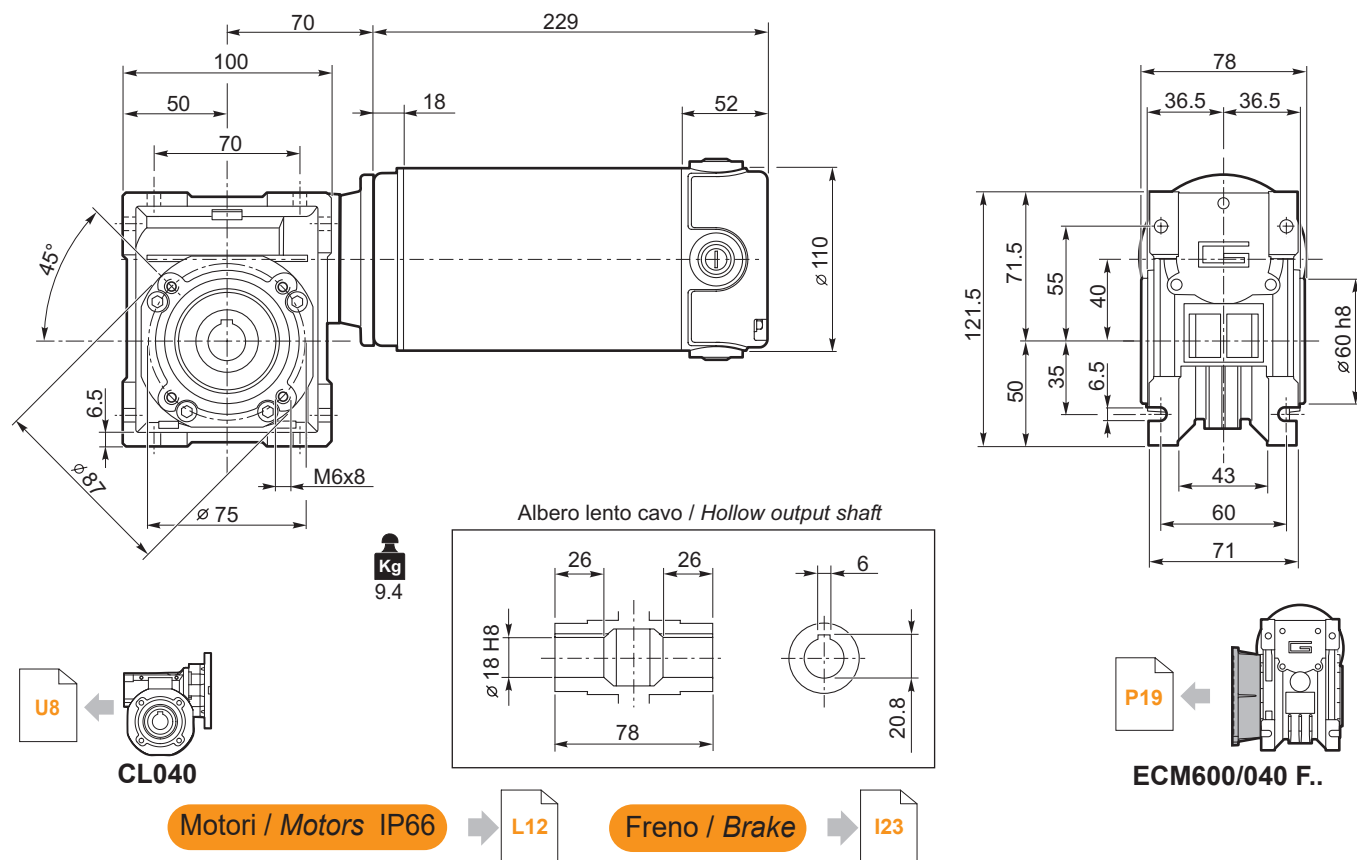

ECM600/050 U

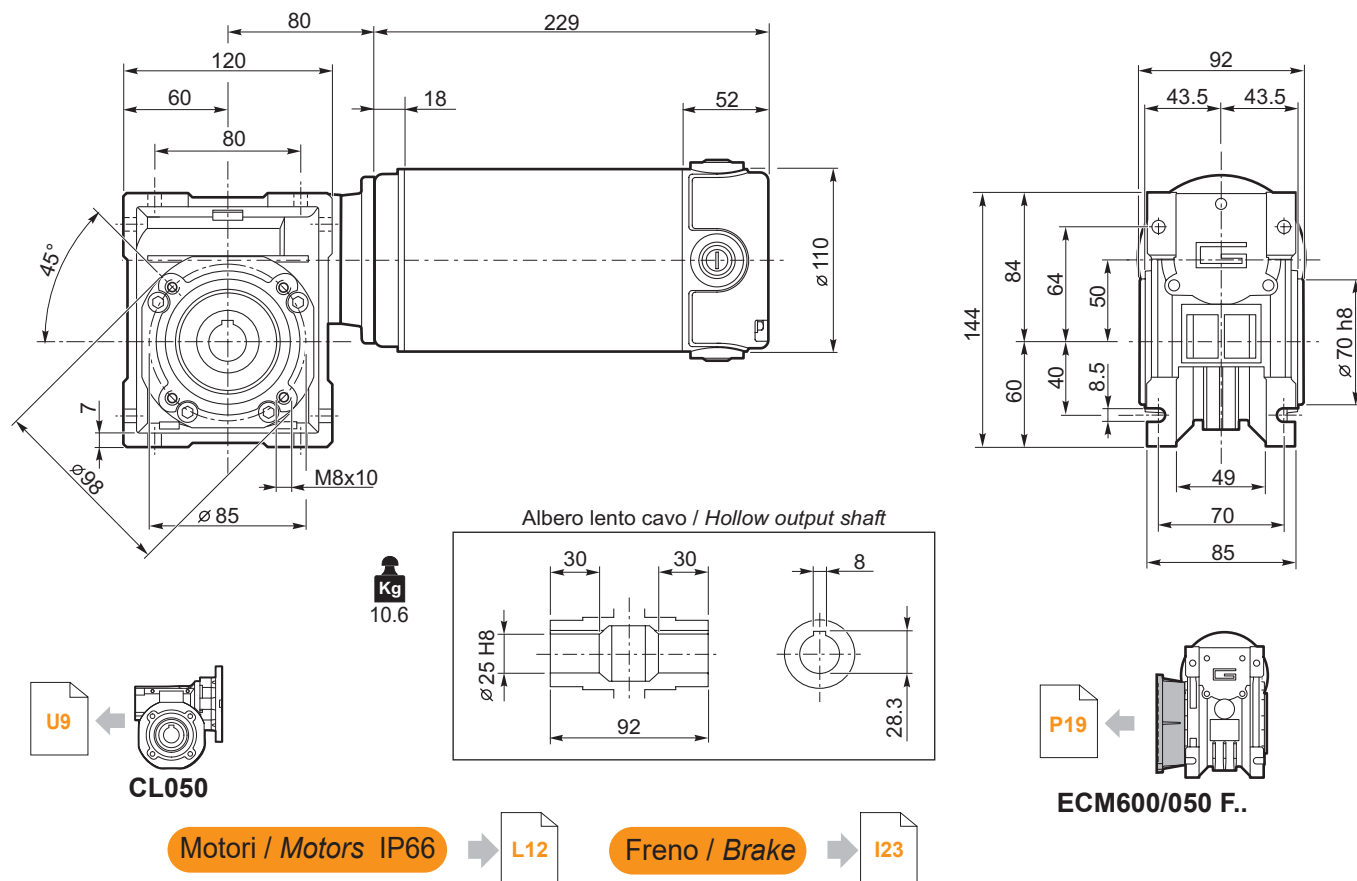

ECM

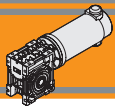

## Dimensioni

## Dimensions

### ECM600/063 U

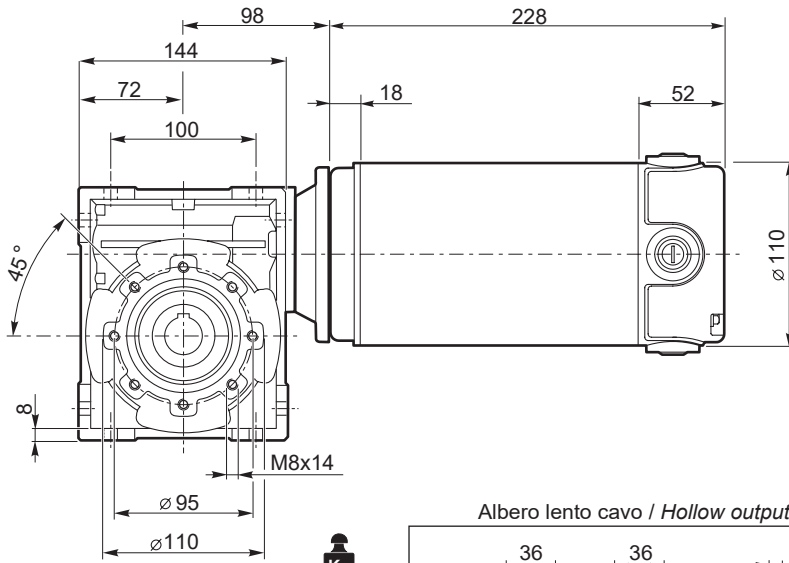

**Kg**  
13.3

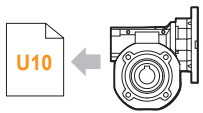

**CL063**

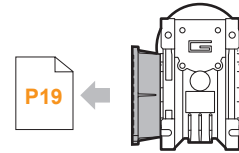
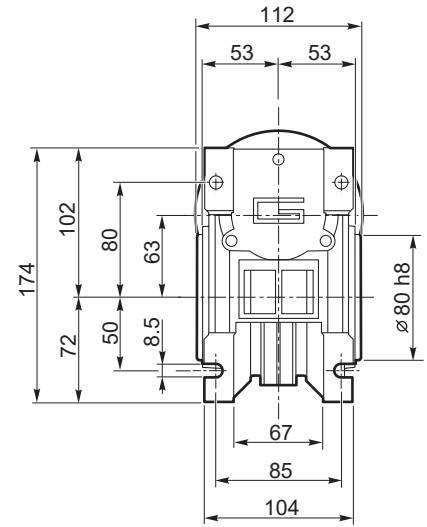
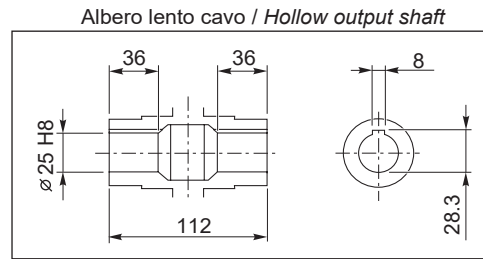

**ECM600/063 F..**

Motori / Motors IP66



Freno / Brake



### ECM600/070 U

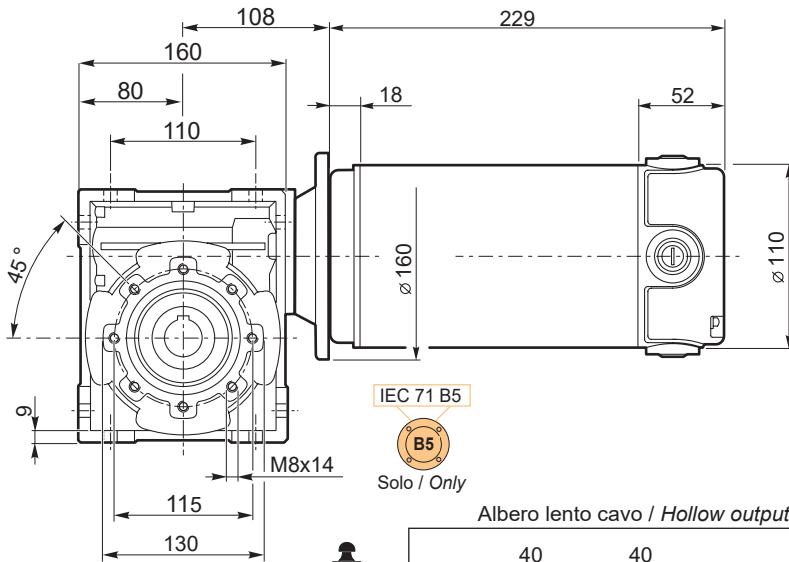

IEC 71 B5

**B5**  
Solo / Only

**Kg**  
14.6

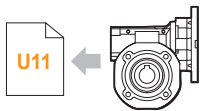

**CL070**

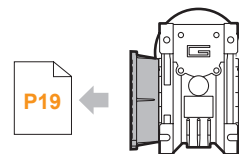
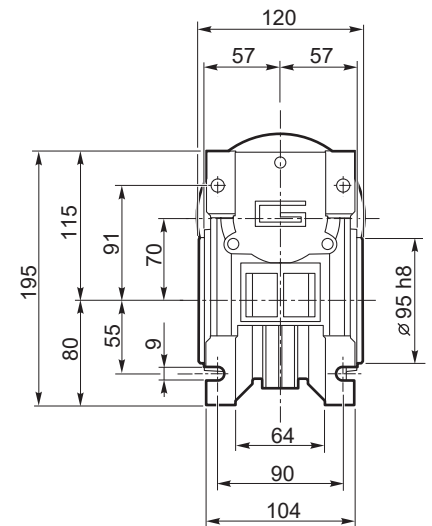
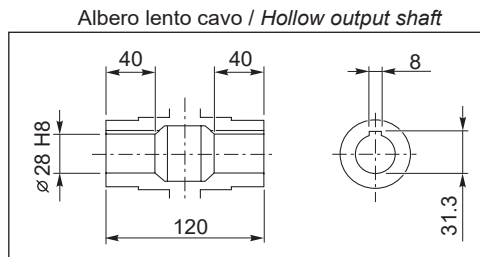

**ECM600/070 F**

Freno / Brake





Dimensioni

Dimensions

ECM.../... F... Flange uscita / Output flanges

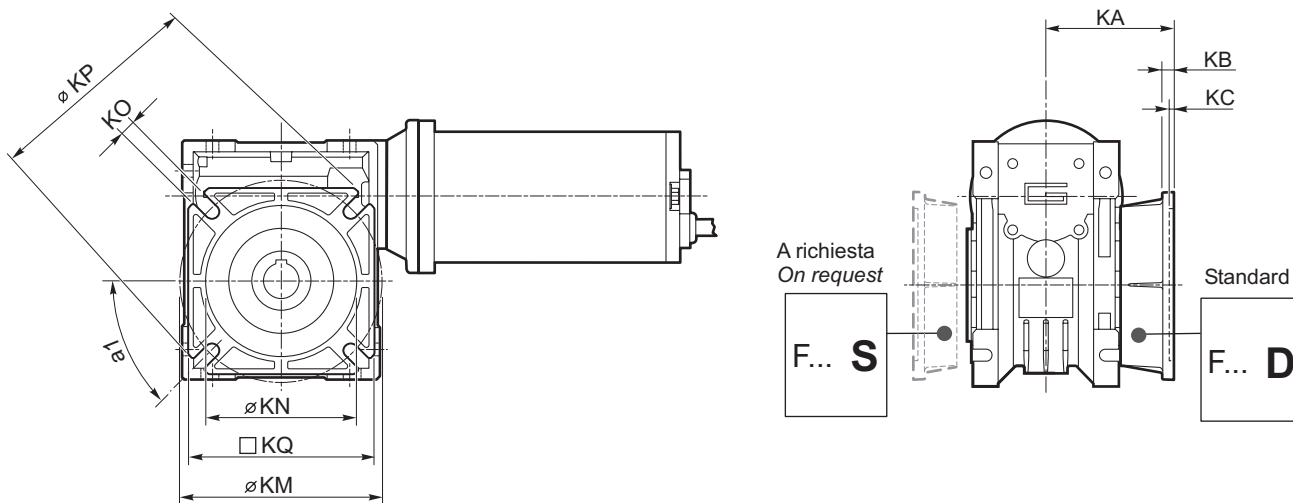

	CM..F							CM..F28							CM..F30										
	a1	KA	KB	KC	KM	KN <sub>H8</sub>	KO	KP	KQ	KA	KB	KC	KM	KN <sub>H8</sub>	KO	KP	KQ	KA	KB	KC	KM	KN <sub>H8</sub>	KO	KP	KQ
026 (D11) 026 026 (D14)	45°	45	6	4.5	55-69	40	6.5(n.4)	75	70	44	6.5	5	56-64	40	6.5	70	60	48	6.5	5	68	50	6.5	80	70

CM	CM..F							CM..FB							CM..FL										
	a1	KA	KB	KC	KM	KN <sub>H8</sub>	KO	KP	KQ	KA	KB	KC	KM	KN <sub>H8</sub>	KO	KP	KQ	KA	KB	KC	KM	KN <sub>H8</sub>	KO	KP	KQ
030	45°	54.5	6	4	68	50	6.5(n.4)	80	70	—	—	—	—	—	—	—	—	—	—	—	—	—	—	—	—
040	45°	67	7.5	4	80-95	60	9(n.4)	110	95	80	8.5	5	115-125	95	9.5(n.4)	140	112	97	7.5	4.5	80-95	60	9(n.4)	110	95
050	45°	90	9	5	90-110	70	11(n.4)	125	110	89	9	5	130-145	110	9.5(n.4)	160	132	120	9	5	90-110	70	11(n.4)	125	110
063	45°	82	10	6	150-160	115	11(n.4)	180	142	98	10	5	165-180	130	11(n.4)	200	160	112	10	6	150-160	115	11(n.4)	180	142
070	45°	107	13	6	165-180	130	14(n.4)	200	170	—	—	—	—	—	—	—	—	—	—	—	—	—	—	—	—

EC100.24E  
EC180.24E

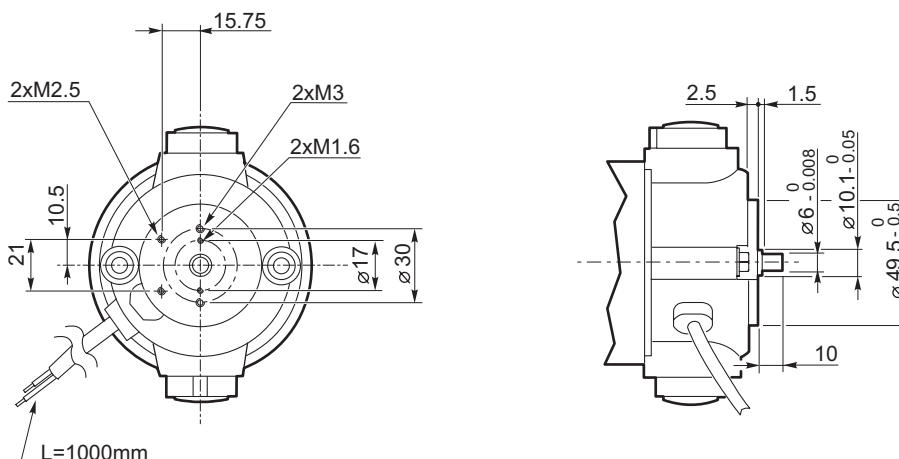

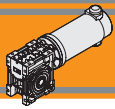

**VS - Vite sporgente / Extended input shaft**

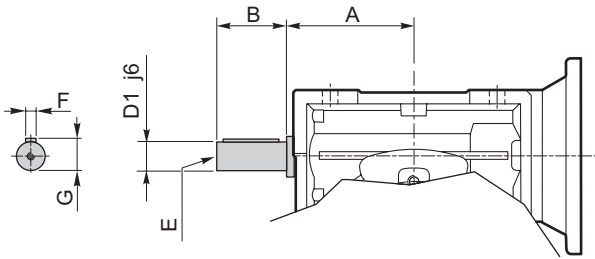

	A	B	D <sub>1</sub> j6	E	F	G
CM 030	45	20	9	M4	3	10.2
CM 040	53	23	11	M5	4	12.5
CM 050	64	30	14	M6	5	16
CM 063	75	40	19	M6	6	21.5
CM 070	84	40	19	M6	6	21.5

Costruito su richiesta  
Built on request

**SC - Safety cover**

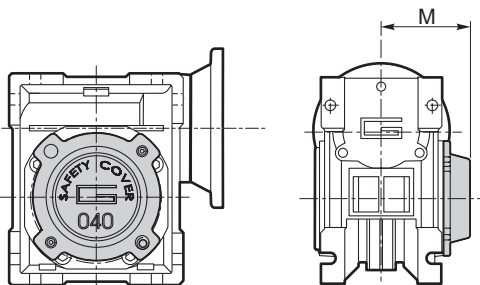

	M
CM 030	47
CM 040	54.5
CM 050	62.5
CM 063	73
CM 070	75

**WD - Washdown cover**

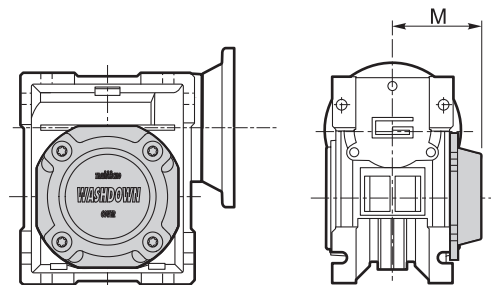

	M
CM 030	48
CM 040	55.5
CM 050	63.5
CM 063	71.5
CM 070	76



Accessori

Accessories

Albero lento

Output shaft

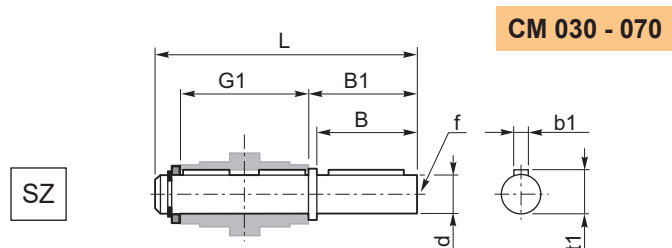
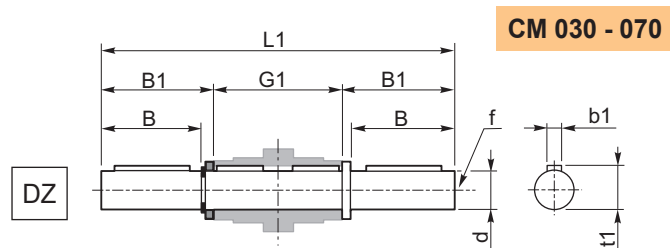

	d h7	B	B1	G1	L	L1	f	b1	t1
CM 030	14	30	32.5	63	102	128	M6	5	16
CM 040	18	40	43	78	128	164	M6	6	20.5
CM 050	25	50	53.5	92	153	199	M10	8	28
CM 063	25	50	53.5	112	173	219	M10	8	28
CM 070	28	60	63.5	120	192	247	M10	8	31

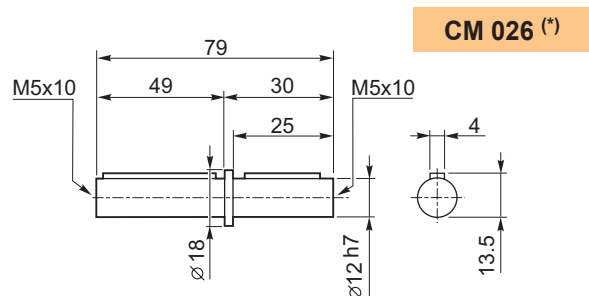

(\*)  
Nota: disponibile solo per cavo uscita Ø12  
Note: available for output hollow shaft Ø12 only

Braccio di reazione

Torque arm

	K1	G	KG	KH	R
CM 030	85	14	23	8	15
CM 040	100	14	31	10	18
CM 050	100	14	38	10	18
CM 063	150	14	47.5	10	18
CM 070	200	25	46.5	20	30

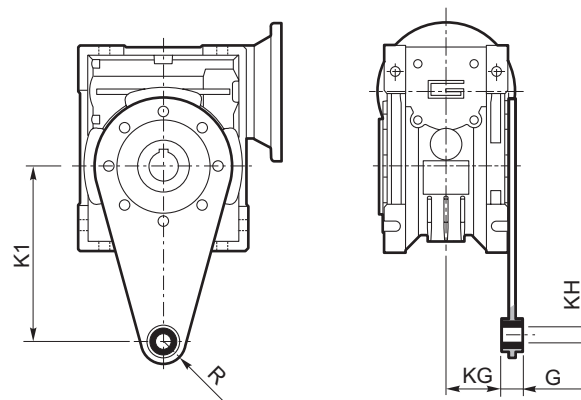





Ferrite

Motoriduttori CC a vite senza fine con precoppia  
**DC pre stage wormgearmotors**

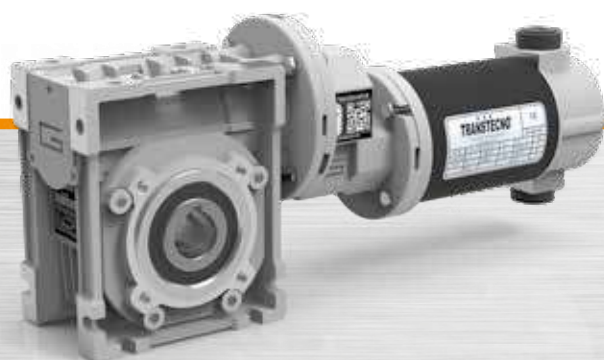



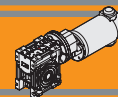

		Pag. Page
<b>Indice</b>	<b>Index</b>	
Caratteristiche tecniche	<i>Technical features</i>	<b>Q2</b>
Designazione	<i>Classification</i>	<b>Q2</b>
Simbologia	<i>Symbols</i>	<b>Q3</b>
Lubrificazione	<i>Lubrication</i>	<b>Q3</b>
Carichi radiali	<i>Radial loads</i>	<b>Q3</b>
Dati tecnici per servizio S2	<i>Technical data for S2 duty</i>	<b>Q4</b>
Motori applicabili	<i>Motor adapters</i>	<b>Q5</b>
Dimensioni	<i>Dimensions</i>	<b>Q6</b>
Opzioni	<i>Options</i>	<b>Q19</b>
Accessori	<i>Accessories</i>	<b>Q19</b>

Questa sezione annulla e sostituisce ogni precedente edizione o revisione. Qualora questa sezione non Vi sia giunta in distribuzione controllata, l'aggiornamento dei dati ivi contenuto non è assicurato. **In tal caso la versione più aggiornata è disponibile sul nostro sito internet [www.transtecno.com](http://www.transtecno.com)**

*This section replaces any previous edition and revision. If you obtained this catalogue other than through controlled distribution channels, the most up to date content is not guaranteed. **In this case the latest version is available on our web site [www.transtecno.com](http://www.transtecno.com)***

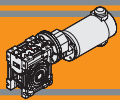

### Caratteristiche tecniche

### Technical features

Le caratteristiche principali dei motoriduttori CC a vite senza fine con precoppia a magneti permanenti in ferrite serie ECMP sono:

The main features of ECMP ferrite permanent magnets DC pre stage wormgearmotors range are:

- Alimentazione in bassa tensione 12/24 Vcc
- Possibilità di montaggio encoder
- Potenze motore disponibili da 100 a 800W S2
- Magneti in ferrite
- Sia le carcasse dei riduttori a vite senza fine che delle precoppie sono in pressofusione di alluminio
- Lubrificazione permanente con olio sintetico

- Low voltage power supply 12/24 Vdc
- Suitable for encoder assembly
- Motor power ratings available from 100 up to 800W S2
- Ferrite magnets
- Die-cast aluminum housing on pre-stage and wormgearboxes
- Permanent synthetic oil long-life lubrication.

### Designazione

### Classification

MOTORIDUTTORE / GEARMOTOR													
ECMP	070/056/030				U	90	SZDX	BRSX	90	P4	240	VS	SC
Tipo Type	Grandezza Size				Versione Riduttore Gearbox Version	Rapporto Ratio	Albero di uscita Output shaft	Braccio di reazione Torque arm	Angolo Angle	Pos. di montaggio precoppia Pre stage mounting position	Versione Motore Motor Version	Opzioni Options	Accessori Accessories
	070/056/030	180/056/030	350/063/050	600/071/050	U	Vedere tabella  See tables	SZDX SZSX DZ	BRDX BRSX  *	0° 90° 180° 270°	P1 P2 P3 (standard) P4	120 240 24E	VS**	SC Safety cover  WD Washdown cover
	070/056/040	180/056/040	350/063/063	600/071/063	FD								
		180/063/040	350/071/063	600/071/070	FS								
		180/063/050	350/071/070	600/071/075	FLD								
		180/063/063	350/071/075		FLS								
					FBD								
					FBS								
	100/056/030												
	100/056/040	250/063/040											
	100/063/050	250/063/050											
		250/063/063											
		250/071/070											
	250/071/075												

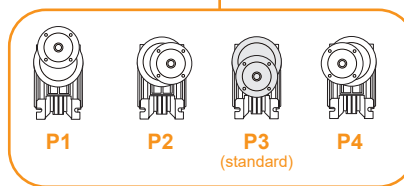

Versione Riduttore  
Gearbox Version

U    FD    FS  
FLD    FLS    FBS  
FBD

Albero di uscita  
Output shaft

SZDX    SZSX    DZ

Braccio di reazione  
Torque arm \*

BRDX    BRSX

Angolo  
Angle

90°    90°  
180°    270°  
270°    0°

\* NOTA: il braccio di reazione viene fornito smontato.  
NOTE: the torque arm will be supplied not assembled.

\*\* NOTA: Vite sporgente costruita su richiesta  
NOTE: Extended input shaft built on request

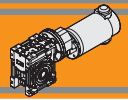

**Simbologia**

**Symbols**

$n_1$ [min <sup>-1</sup> ]	Velocità in ingresso / <i>Input speed</i>	$M_2$ [Nm]	Coppia in uscita in funzione di $P_1$ / <i>Output torque referred to <math>P_1</math></i>
$n_2$ [min <sup>-1</sup> ]	Velocità in uscita / <i>Output speed</i>	sf	Fattore di servizio / <i>Service factor</i>
$i$	Rapporto di riduzione / <i>Ratio</i>	$R_2$ [N]	Carico radiale ammissibile in uscita / <i>Permitted output radial load</i>
$P_1$ [kW]	Potenza in entrata / <i>Input power</i>	$A_2$ [N]	Carico assiale ammissibile in uscita / <i>Permitted output axial load</i>

**Lubrificazione**

**Lubrication**

I riduttori a vite senza fine con precoppia della serie CMP sono lubrificati a vita con olio sintetico di viscosità 320 e possono essere installati in qualunque posizione di montaggio.

*Permanent synthetic oil long - life lubrication allow to use CMP range in all mounting positions.*

**Carichi radiali**

**Radial loads**

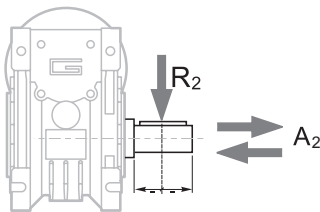

$n_2$ [min <sup>-1</sup> ]	$R_2$ [N]					
	CM030	CM040	CM050	CM063	CM070	CM075
35	1179	2210	3095	4273	4568	4937
28	1270	2381	3334	4603	4921	5318
23	1356	2542	3559	4915	5254	5678
18	1471	2759	3862	5334	5702	6162
14	1600	3000	4200	5800	6200	6700

Quando il carico radiale risultante non è applicato sulla mezzera dell'albero occorre calcolare quello effettivo con la seguente formula:

*When the resulting radial load is not applied on the centre line of the shaft it is necessary to calculate the effective load with the following formula:*

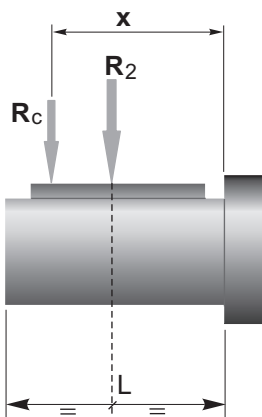

$$R_c = \frac{R_2 \cdot a}{(b+x)} \leq R_{2MAX}$$

$$R \leq R_c$$





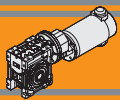





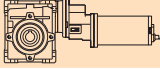
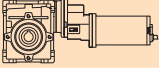
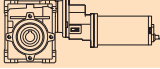
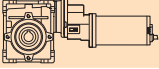
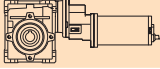
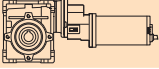
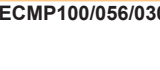

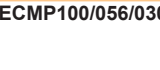

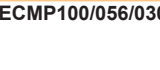

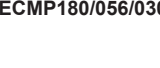
*a, b = valori riportati nella tabella*  
*a, b = values given in the table*

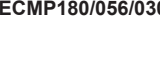
	CM					
	030	040	050	063	070	075
<b>a</b>	65	84	101	120	122	131
<b>b</b>	50	64	76	95	92	101
<b><math>R_{2MAX}</math></b>	1600	3000	4200	5800	6200	6700

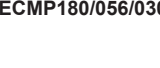

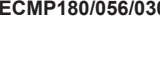
### Dati tecnici per servizio S2

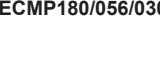
### Technical data for S2 duty

100							350						
$P_1$ [W]	$n_2$ [min <sup>-1</sup> ]	$M_2$ [Nm]	sf	i		Versione motore Motor version	$P_1$ [W]	$n_2$ [min <sup>-1</sup> ]	$M_2$ [Nm]	sf	i		Versione motore Motor version
<b>100</b>							<b>350</b>						
(3000 min <sup>-1</sup> )	50	13	1.7	60		ECMP070/056/030 12E/24E 120.66/240.66	(3000 min <sup>-1</sup> )	50	48	0.9	60		ECMP250/063/040 120/240 120.66/240.66
	40	16	1.4	75				40	57	0.8	75		
	33	17	1.6	90				33	65	0.9	90		
	25	22	1.1	120				25	69	0.7	120		
	20	25	0.9	150				25	69	0.7	120		
	50	14	3.2	60		ECMP070/056/040 12E/24E 120.66/240.66		50	49	1.6	60		ECMP250/063/050 120/240 120.66/240.66
	40	16	2.7	75				40	59	1.3	75		
	33	19	3.0	90				33	67	1.5	90		
	25	22	2.1	120				25	81	1.0	120		
	20	27	1.7	150				20	97	0.8	150		
	17	30	1.4	180		17	108	0.7	180				
	13	34	1.2	240		13	99	0.7	240				
	10	38	0.9	300		10	99	0.7	240				
<b>140</b>							<b>500</b>						
(3000 min <sup>-1</sup> )	50	19	1.2	60		ECMP100/056/030 120/240/24E 120.66/240.66	(3000 min <sup>-1</sup> )	50	51	3.0	60		ECMP250/063/063 120/240 120.66/240.66
	40	22	1.0	75				40	61	2.2	75		
	33	24	1.1	90				33	69	2.7	90		
	25	30	0.8	120				25	85	1.9	120		
	20	31	0.7	150				20	100	1.5	150		
	50	19	2.3	60		ECMP100/056/040 120/240/24E 120.66/240.66		25	88	2.7	120		ECMP250/071/070 120/240 IEC 71B14 Solo / Only
	40	23	1.9	75				20	103	2.1	150		
	33	26	2.2	90				17	118	1.8	180		
	25	31	1.5	120				13	142	1.3	240		
	20	37	1.2	150				10	161	1.0	300		
	17	42	1.0	180		17	118	2.1	180				
	13	48	0.8	240		13	144	1.6	240				
	10	54	0.7	300		10	164	1.3	300				
	50	20	4.1	60		ECMP100/063/050 120/240/24E IEC 63B14 Solo / Only		17	118	2.1	180		ECMP250/071/075 120/240 IEC 71B14 Solo / Only
	40	24	3.2	75				13	144	1.6	240		
	33	27	3.7	90				10	164	1.3	300		
	25	32	2.6	120									
	20	39	2.1	150									
	17	43	1.8	180									
	13	50	1.4	240									
<b>250</b>							<b>500</b>						
(3000 min <sup>-1</sup> )	50	33	0.7	60		ECMP180/056/030 120/240 120.66/240.66	(3000 min <sup>-1</sup> )	50	70	1.1	60		ECMP350/063/050 120/240 120.66/240.66
	40	31	0.7	75				40	84	0.9	75		
	33	39	0.7	90				33	95	1.0	90		
	25	33	0.7	120				25	116	0.7	120		
	20	31	0.7	150				20	116	0.7	150		
	50	35	1.3	60		ECMP180/056/040 120/240 120.66/240.66		17	109	0.7	180		ECMP350/063/063 120/240 120.66/240.66
	40	41	1.1	75				13	99	0.7	240		
	33	46	1.2	90				50	73	2.1	60		
	25	56	0.9	120				40	88	1.6	75		
	20	67	0.7	150				33	98	1.9	90		
	17	61	0.7	180		25	122	1.3	120				
	13	57	0.7	240		20	143	1.1	150				
	10	51	0.7	300		17	163	0.9	180				
	50	35	1.3	60		ECMP180/063/040 24E IEC 63B14 Solo / Only		13	195	0.7	240		ECMP350/063/063 120/240 120.66/240.66
	40	41	1.1	75				10	174	0.7	300		
	33	46	1.2	90				50	73	2.1	60		
	25	56	0.9	120				40	88	1.6	75		
	20	67	0.7	150				33	98	1.9	90		
	17	61	0.7	180		25	122	1.3	120				
	13	57	0.7	240		20	143	1.1	150				
	10	51	0.7	300		17	163	0.9	180				
	50	35	2.3	60		ECMP180/063/050 120/240/24E IEC 63B14 Solo / Only		13	195	0.7	240		ECMP350/063/063 120/240 120.66/240.66
	40	42	1.8	75				10	174	0.7	300		
	33	48	2.1	90				50	73	2.1	60		
	25	58	1.5	120				40	88	1.6	75		
	20	69	1.2	150				33	98	1.9	90		
	17	77	1.0	180		25	122	1.3	120				
	13	90	0.8	240		20	143	1.1	150				
	50	37	4.2	60		ECMP180/063/063 120/240/24E IEC 63B14 Solo / Only		17	163	0.9	180		ECMP350/063/063 120/240 120.66/240.66
	40	44	3.1	75				10	174	0.7	300		
	33	49	3.8	90				50	73	2.1	60		
	25	61	2.6	120				40	88	1.6	75		
	20	71	2.1	150				33	98	1.9	90		
	17	81	1.7	180		25	122	1.3	120				
	13	97	1.3	240		20	143	1.1	150				
	10	110	1.1	300		17	163	0.9	180				

NOTA  
Verificare sempre che la coppia M2 utilizzata non ecceda il valore indicato nelle caselle in grigio

NOTE  
Please check that the output torque M2 does not exceed the value in the grey areas





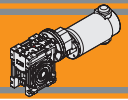

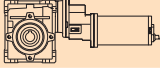
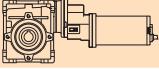
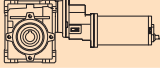

**NOTA:** per servizio continuo o altamente intermittente, contattare il servizio tecnico

**NOTE:** for continuous or highly intermittent duty, please contact our technical service

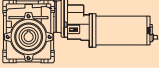
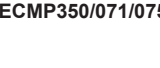

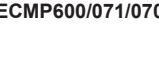
Dati tecnici per servizio S2

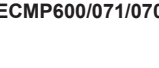
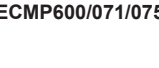
Technical data for S2 duty

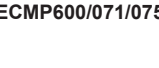
P <sub>1</sub> [W]	n <sub>2</sub> [min <sup>-1</sup> ]	M <sub>2</sub> [Nm]	sf	i		Versione motore Motor version	P <sub>1</sub> [W]	n <sub>2</sub> [min <sup>-1</sup> ]	M <sub>2</sub> [Nm]	sf	i		Versione motore Motor version									
<b>500</b>							<b>800</b>															
(3000 min <sup>-1</sup> )	50	74	3.1	60		ECMP350/071/070	120/240 IEC 71B14  Solo / Only	(3000 min <sup>-1</sup> )	50	112	0.7	60		ECMP600/071/050	120/240							
	40	90	2.2	75					40	107	0.7	75			120.66/240.66							
	33	101	2.7	90					33	141	0.7	90										
	25	125	1.9	120																		
	20	147	1.5	150																		
	17	168	1.3	180																		
	13	202	0.9	240																		
	10	229	0.7	300																		
		50	75	3.7					60		ECMP350/071/075	120/240 IEC 71B14  Solo / Only			(3000 min <sup>-1</sup> )	50	118	1.3	60		ECMP600/071/063	120/240
		40	90	2.7					75							40	140	1.0	75			120.66/240.66
	33	102	3.2	90	33	157	1.2	90														
	25	127	2.3	120	25	195	0.8	120														
	20	150	1.7	150	20	228	0.7	150														
	17	168	1.5	180	17	203	0.7	180														
	13	206	1.1	240																		
	10	234	0.9	300																		
						ECMP600/071/070	120/240 IEC 71B14  Solo / Only	(3000 min <sup>-1</sup> )	50				118	1.9		60		ECMP600/071/070	120/240			
	40	144	1.4	75					40				144	1.4		75			120.66/240.66			
	33	162	1.7	90					33	162	1.7	90										
	25	201	1.2	120					25	201	1.2	120										
	20	236	0.9	150					20	236	0.9	150										
	17	270	0.8	180					17	270	0.8	180										
										ECMP600/071/075	120/240 IEC 71B14  Solo / Only	(3000 min <sup>-1</sup> )	50	118	2.3	60				ECMP600/071/075	120/240	
	40	144	1.7	75									40	144	1.7	75					120.66/240.66	
	33	164	2.0	90									33	164	2.0	90						
	25	204	1.4	120									25	204	1.4	120						
	20	240	1.1	150	20	240	1.1	150														
	17	270	0.9	180	17	270	0.9	180														
	13	329	0.7	240																		
	10	293	0.7	300																		

N.B.  
Verificare sempre che la coppia M2 utilizzata non ecceda il valore indicato nelle caselle in grigio  
N.B.  
Please check that the output torque M2 does not exceed the value in the grey areas

**NOTA:** per servizio continuo o altamente intermittente, contattare il servizio tecnico  
**NOTE:** for continuous or highly intermittent duty, please contact our technical service

Motori applicabili

Motor adapters

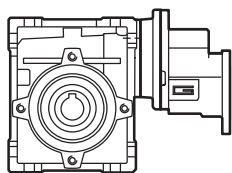
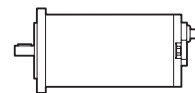

		EC						
		070.12E 070.24E	100.120 100.240 100.24E	180.120 180.240	180.24E	250.120 250.240	350.120 350.240	600.120 600.240
CMP	056/030	150	150	150				
	056/040	300	300	300				
	063/040				120	120		
	063/050		240 <sup>(1)</sup>	240 <sup>(1)</sup>	240	240	240	
	063/063			300 <sup>(1)</sup>	300	300	300	
	071/050							90
	071/063						180 <sup>(2)</sup>	180
	071/070					300 <sup>(2)</sup>	300 <sup>(2)</sup>	180
	071/075					300 <sup>(2)</sup>	300 <sup>(2)</sup>	300

150

Rapporto di riduzione massimo  $i_{max}$   
Maximum ratio  $i_{max}$

(1): Solo IEC 63 B14  
IEC 63 B14 only

(2): Solo IEC 71 B14  
IEC 71 B14 only

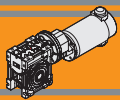

## Dimensioni

## Dimensions

### ECMP070/056/030 U

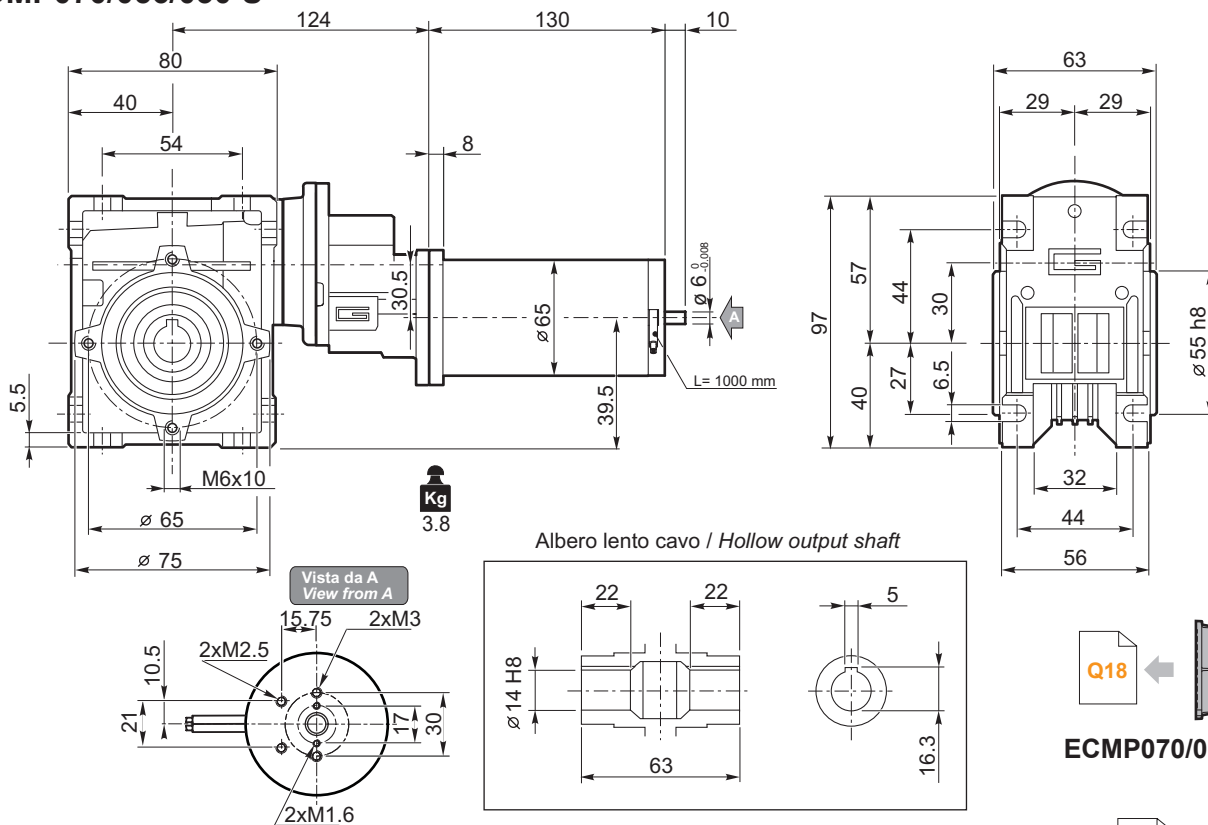

Q18 ← **ECMP070/056/030 F**

Motori / Motors IP66 → L2

Freno / Brake → I23

Encoder → I24

U7 ← **CL030**

### ECMP070/056/040 U

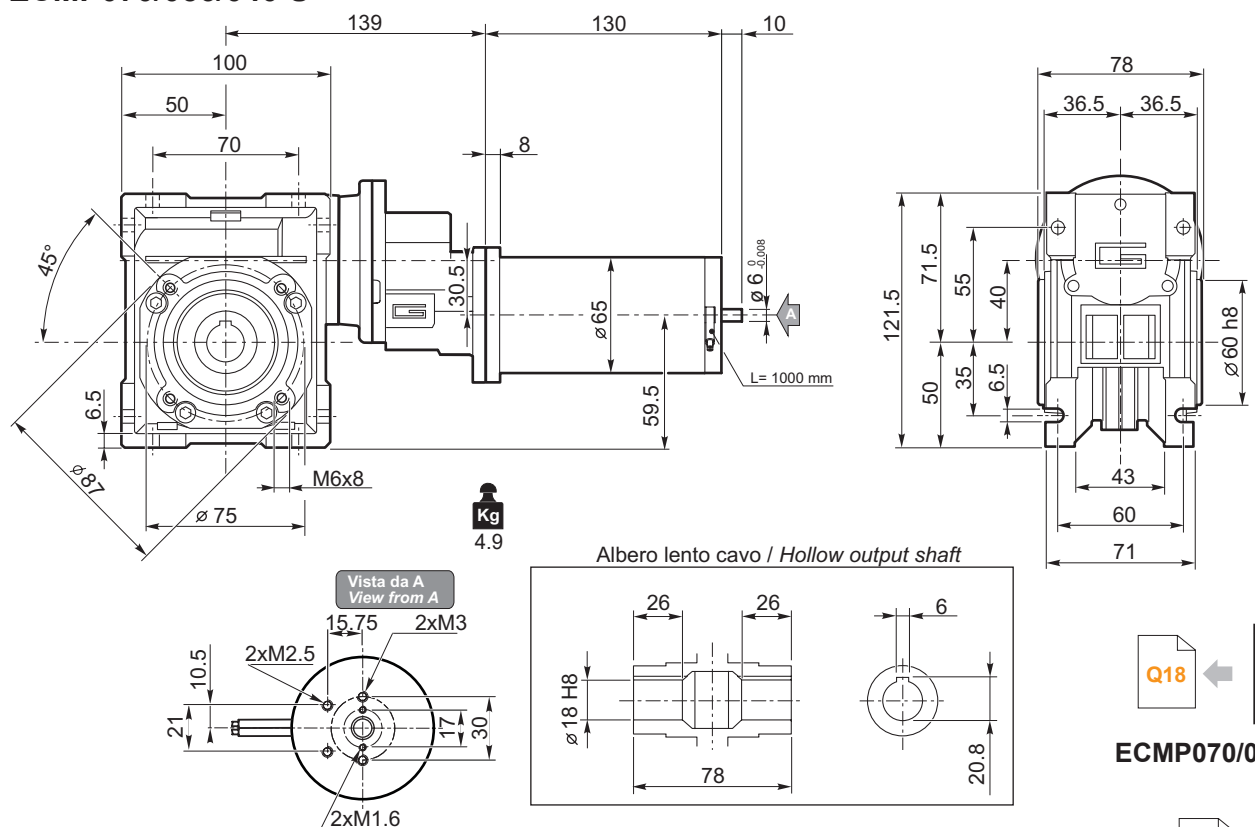

Q18 ← **ECMP070/056/040 F..**

Motori / Motors IP66 → L2

Freno / Brake → I23

Encoder → I24

U8 ← **CL040**

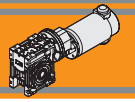

**Dimensioni**

**Dimensions**

**ECMP100/056/030 U**

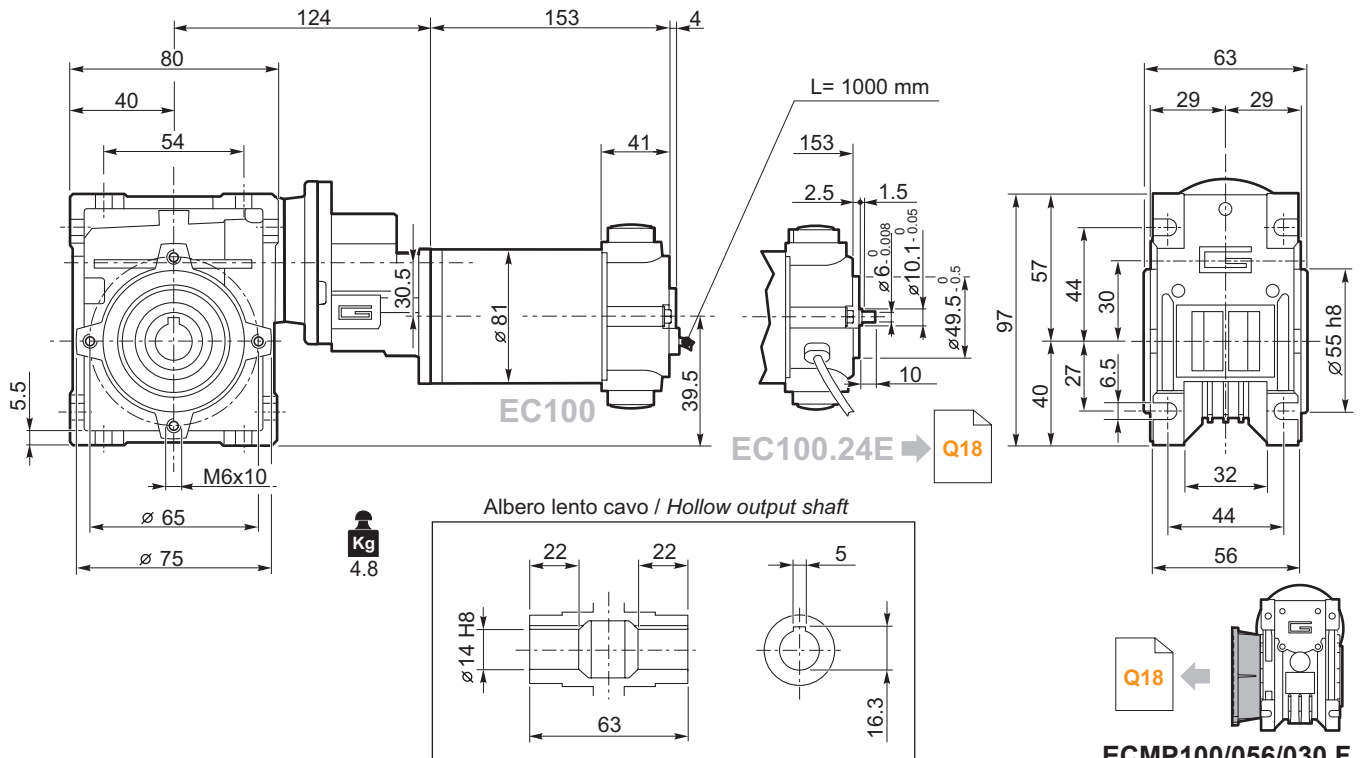

Motori / Motors IP66 → L4

Freno / Brake → I23

Encoder → I24

U7

CL030

**ECMP100/056/040 U**

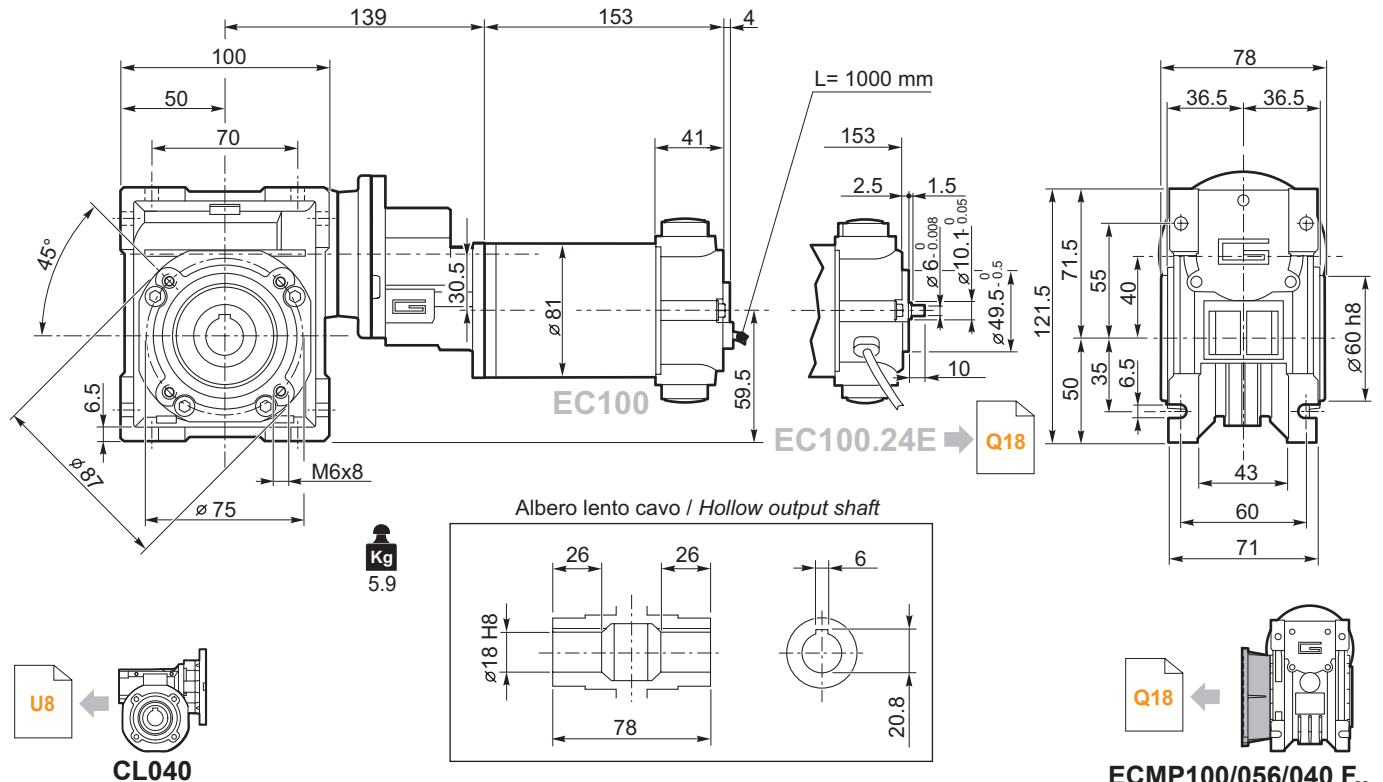

Motori / Motors IP66 → L4

Freno / Brake → I23

Encoder → I24

**ECMP**

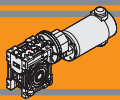

### Dimensioni

### Dimensions

#### ECMP100/063/050 U

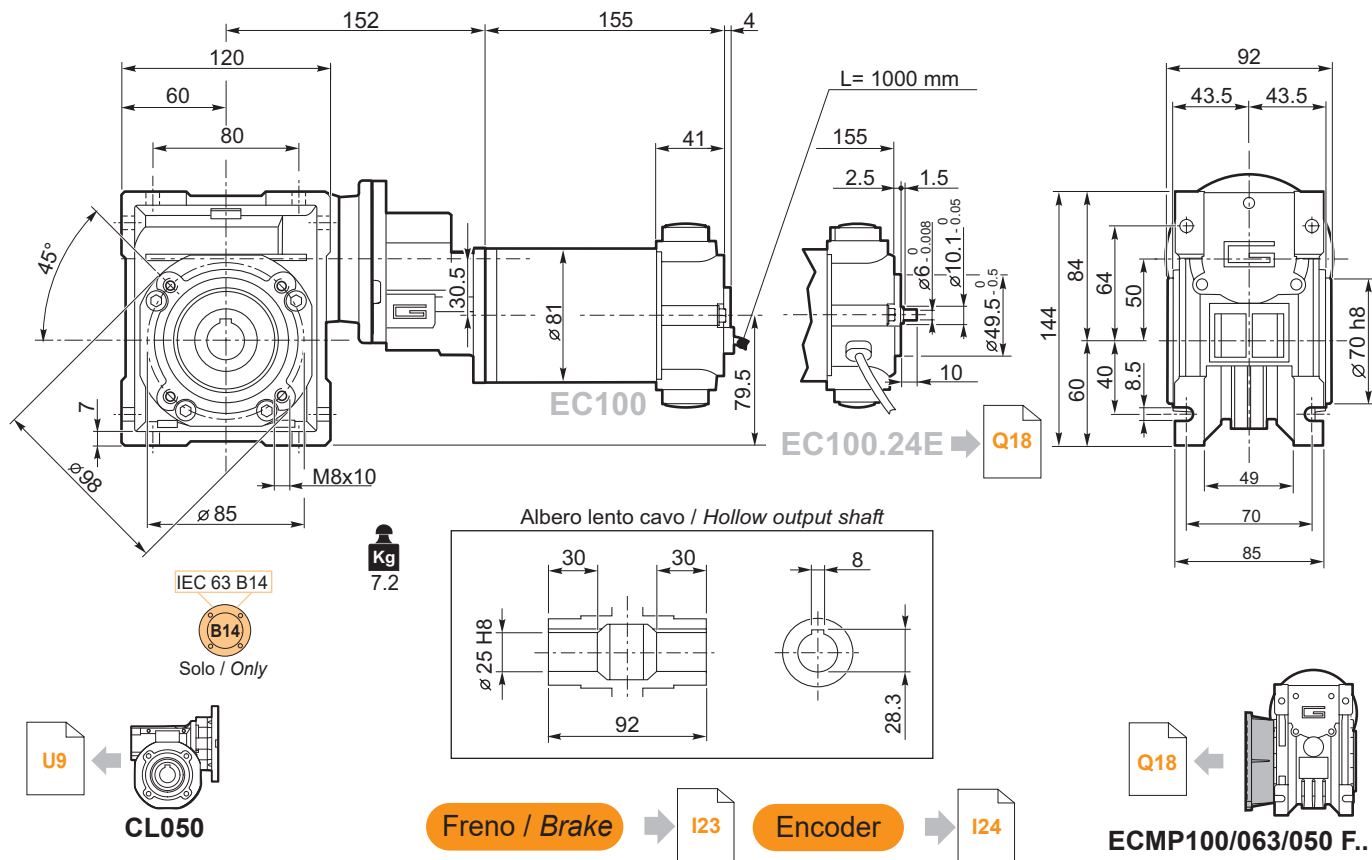

#### ECMP180/056/030 U

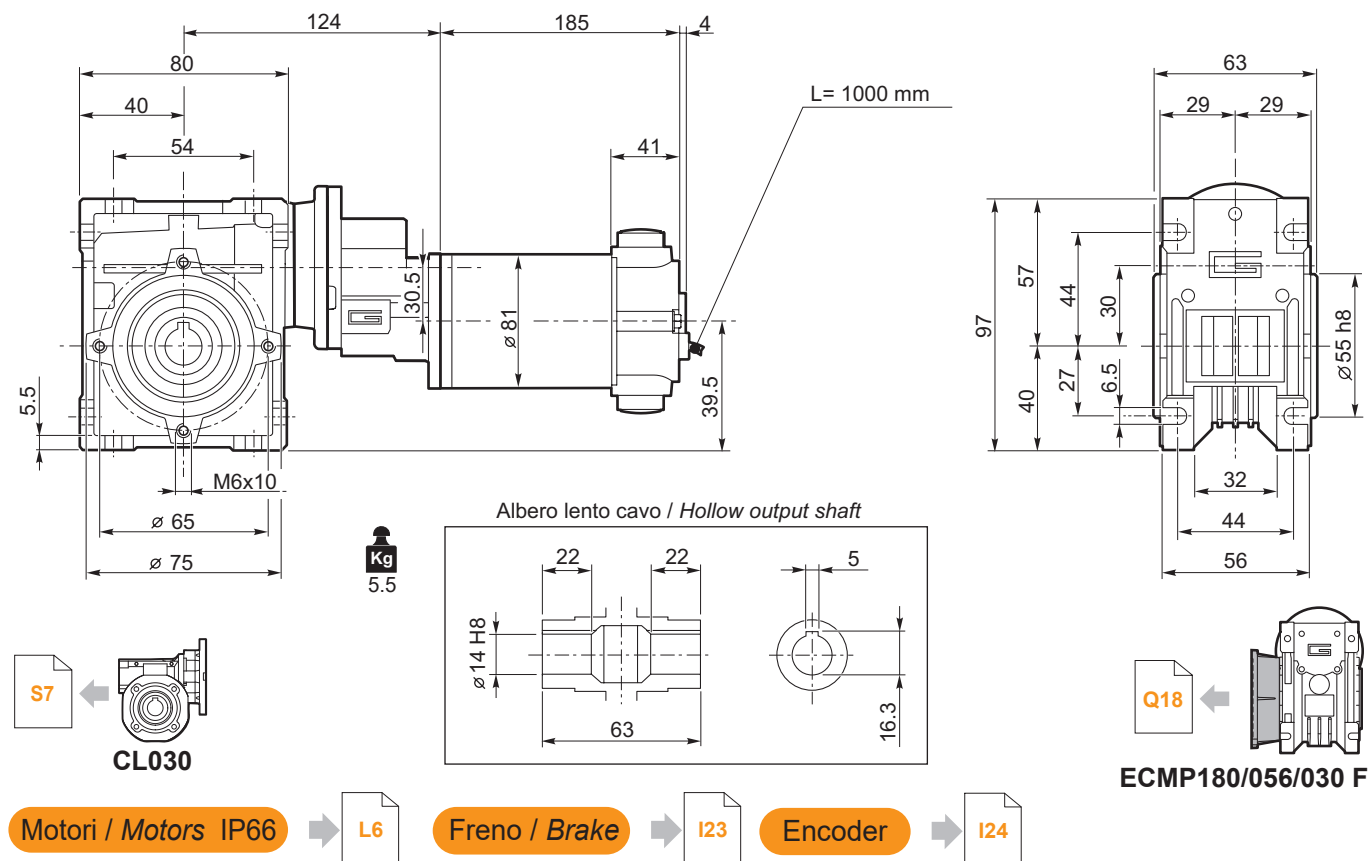

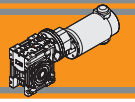

**Dimensioni**

**Dimensions**

**ECMP180/056/040 U**

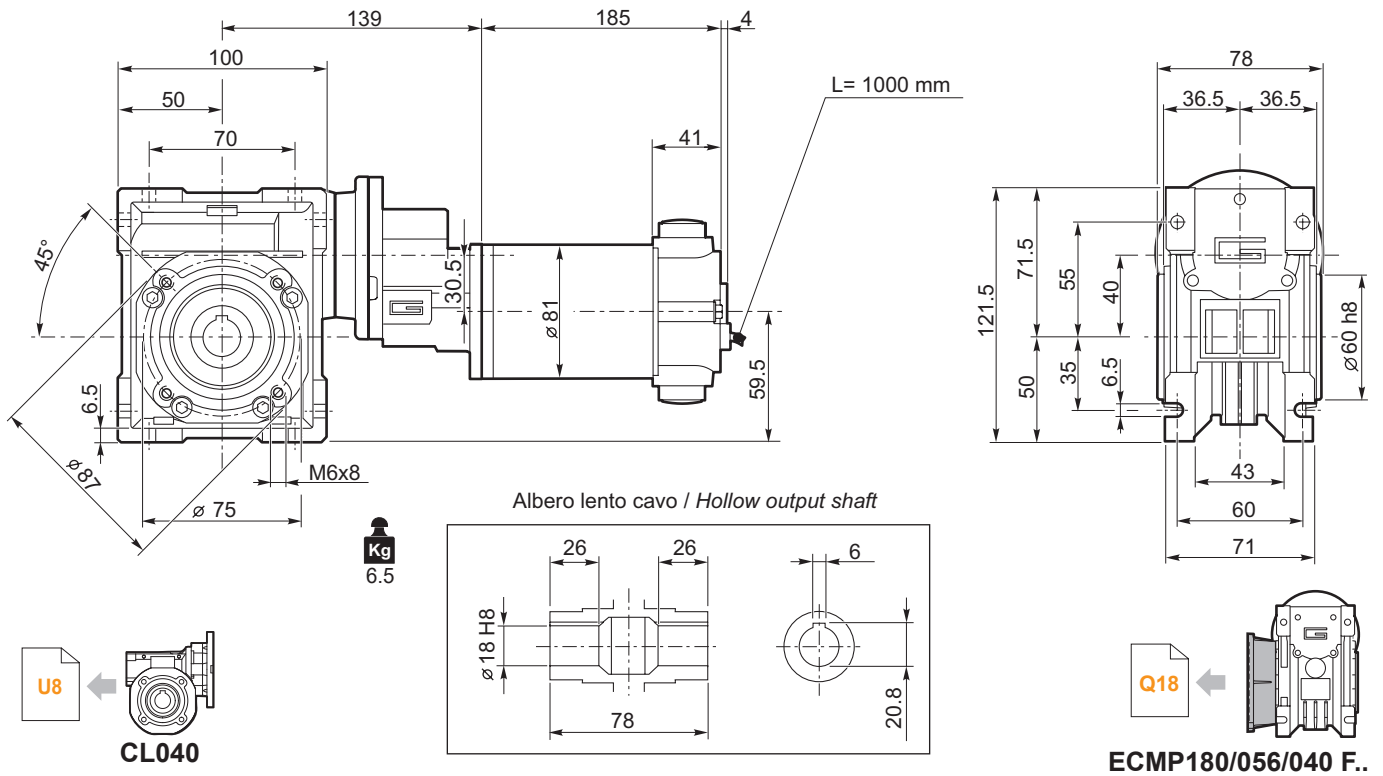

- Motori / Motors IP66** → **L6**
- Freno / Brake** → **I23**
- Encoder** → **I24**

**ECMP180/063/040 U.24E**

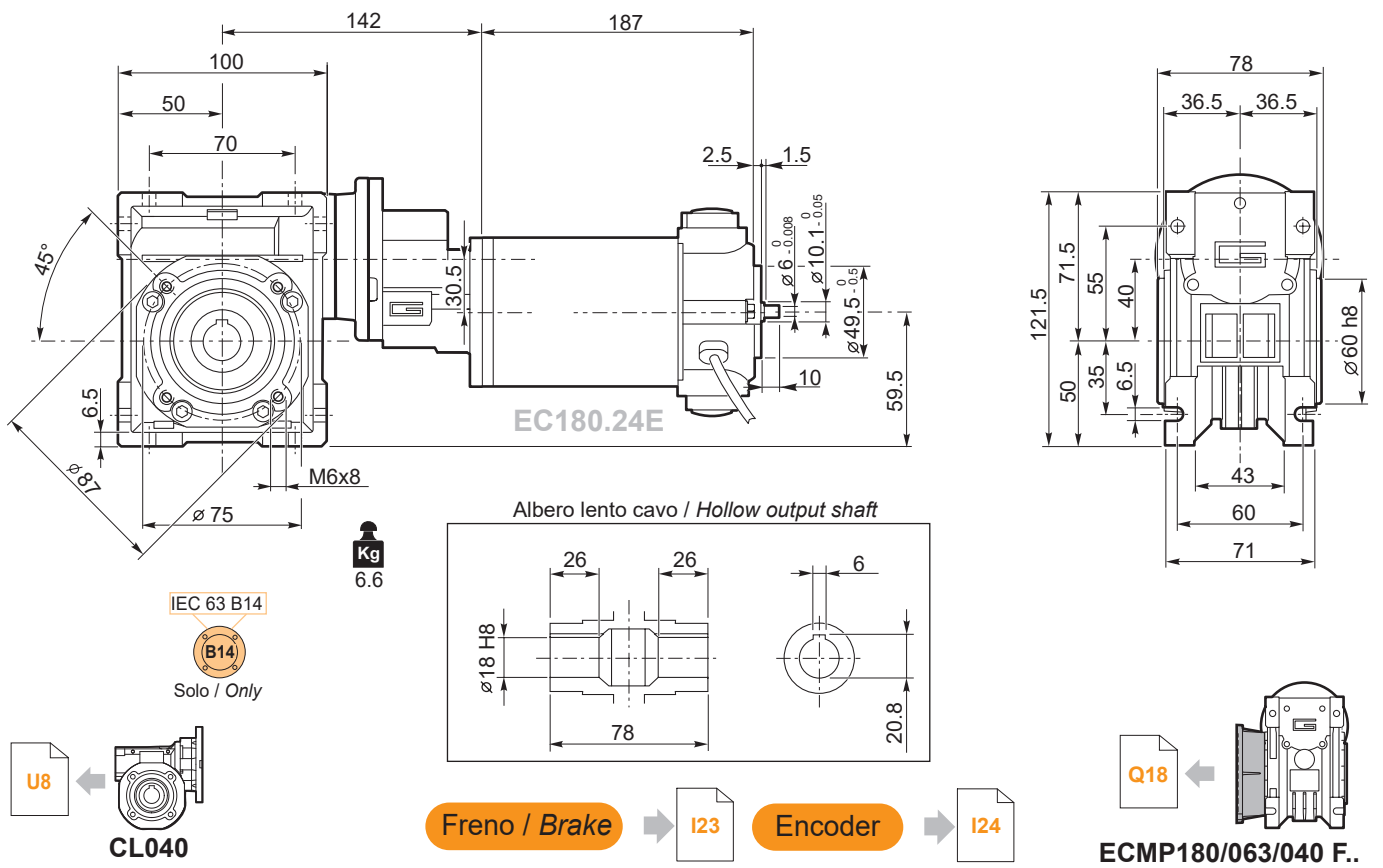

**ECMP**

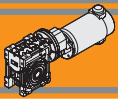

### Dimensioni

### Dimensions

#### ECMP180/063/050 U

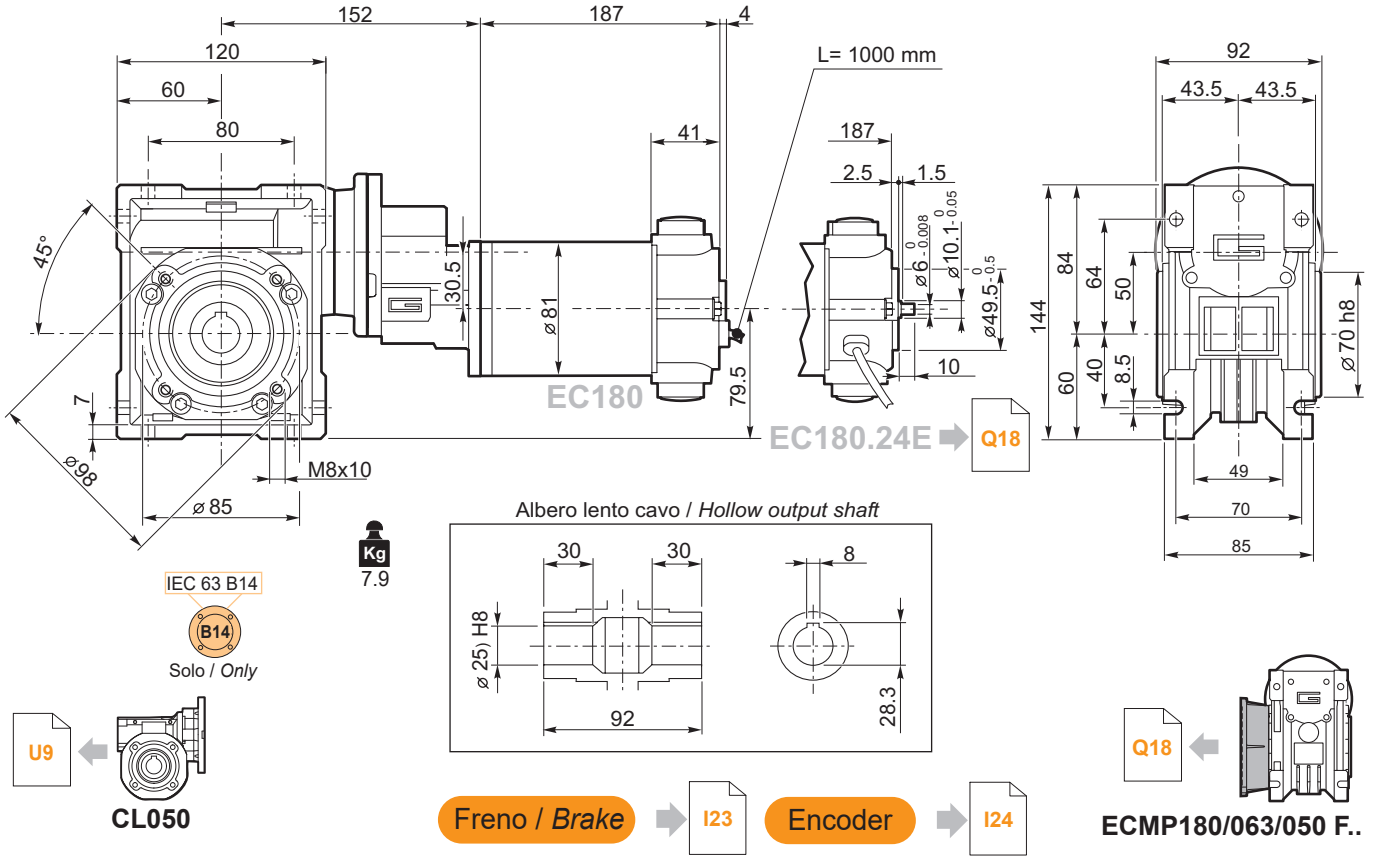

#### ECMP180/063/063 U

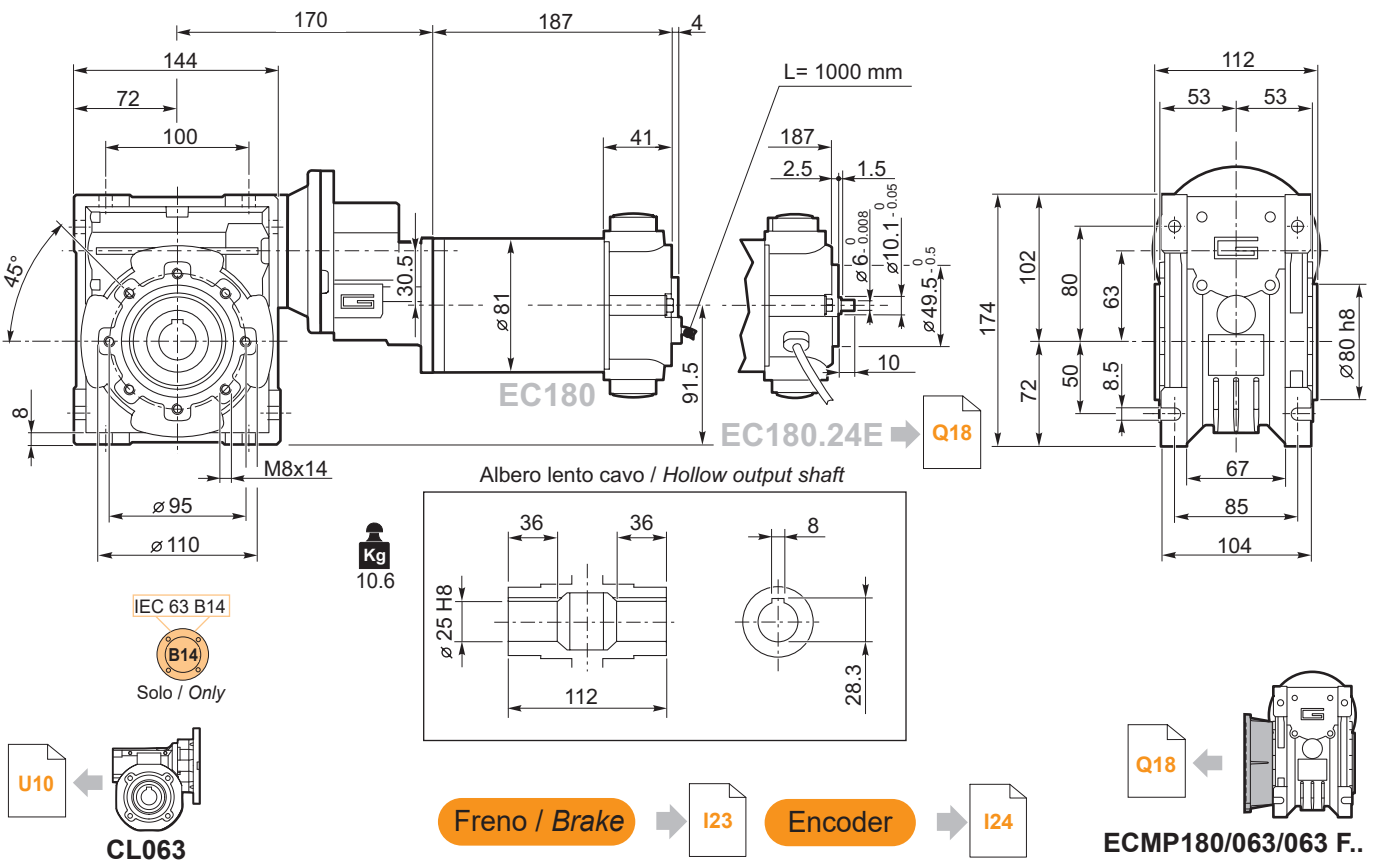

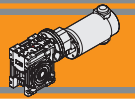

Dimensioni

Dimensions

ECMP250/063/040 U

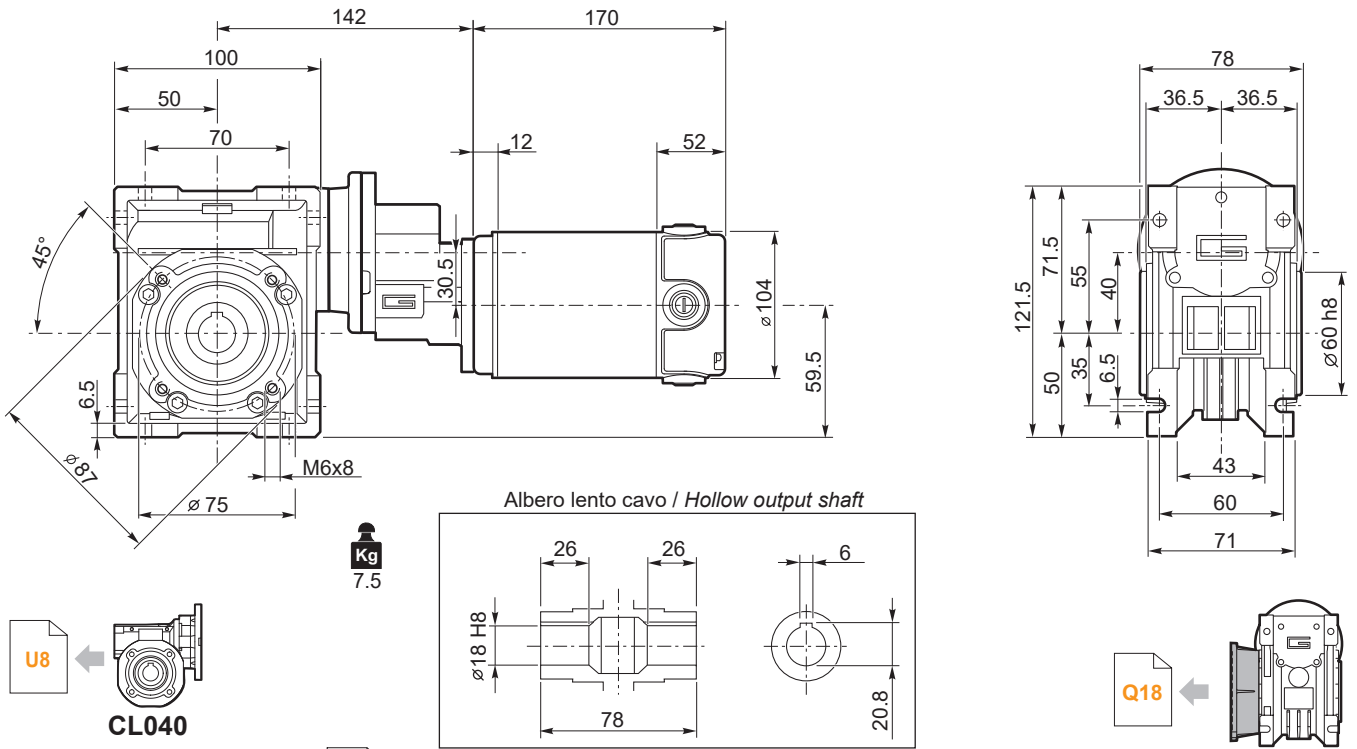

ECMP250/063/050 U

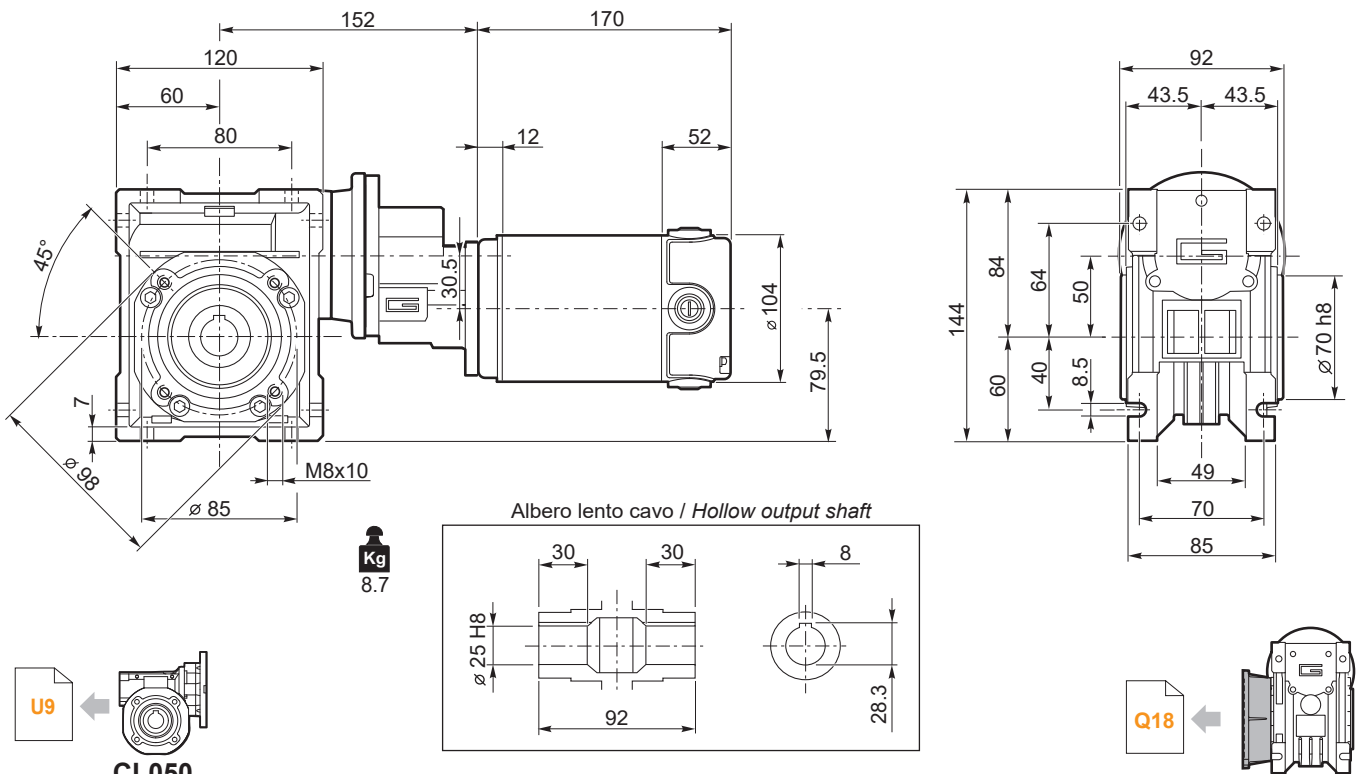

ECMP

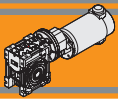

## Dimensioni

## Dimensions

### ECMP250/063/063 U

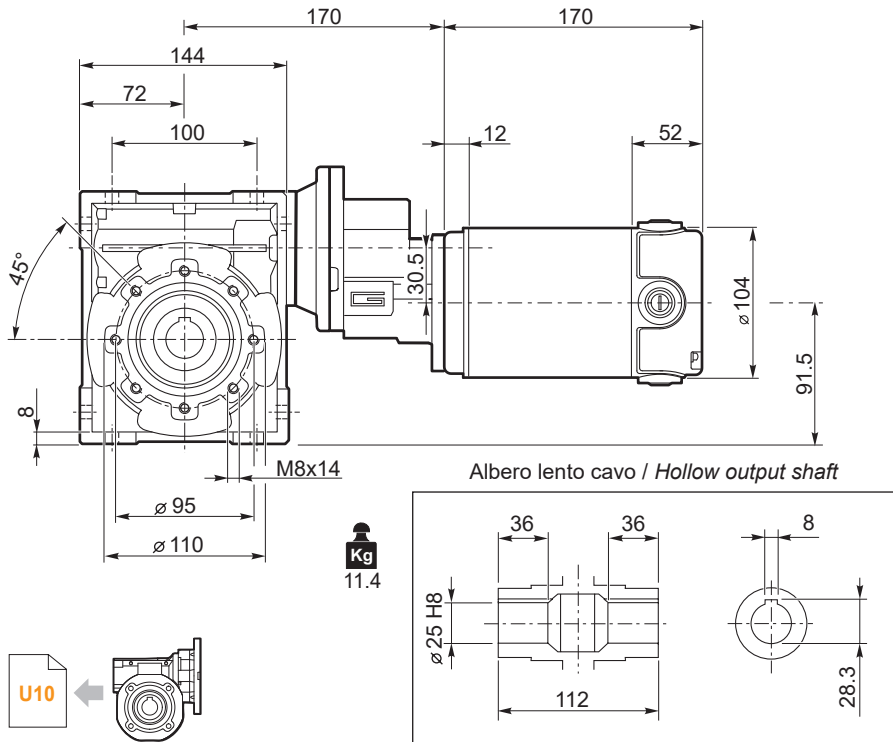

**Kg**  
11.4

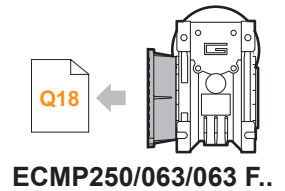
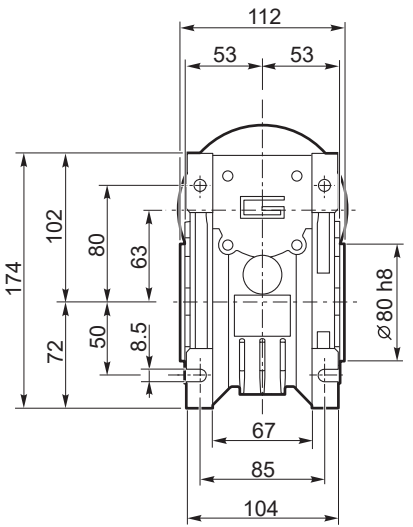
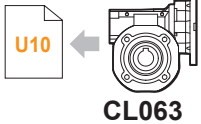

Motori / Motors IP66



### ECMP250/071/070 U

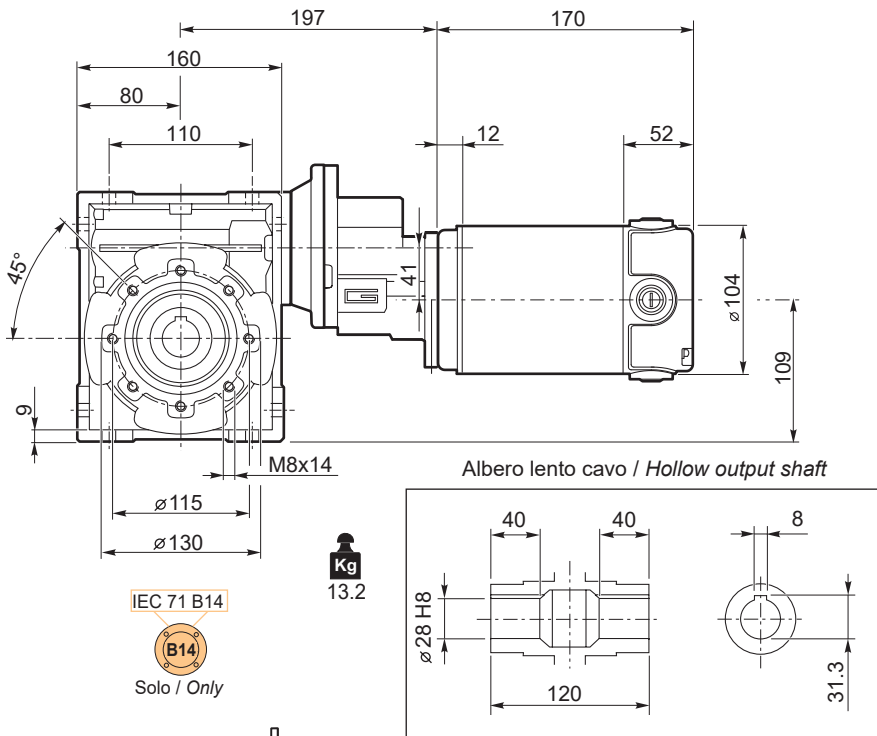

**Kg**  
13.2

IEC 71 B14  
**B14**  
Solo / Only

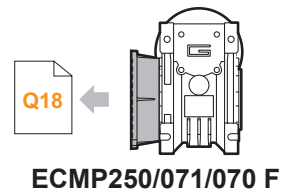
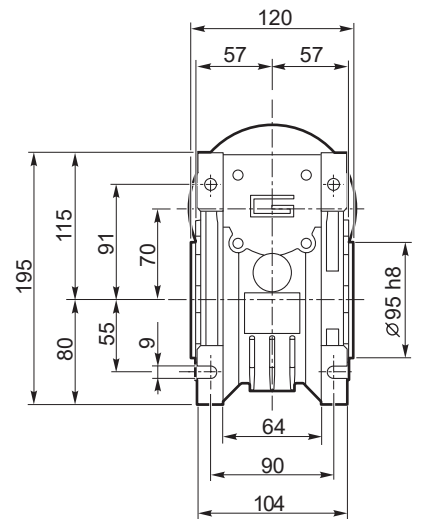
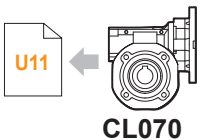



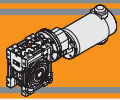

### Dimensioni

### Dimensions

#### ECMP350/063/063 U

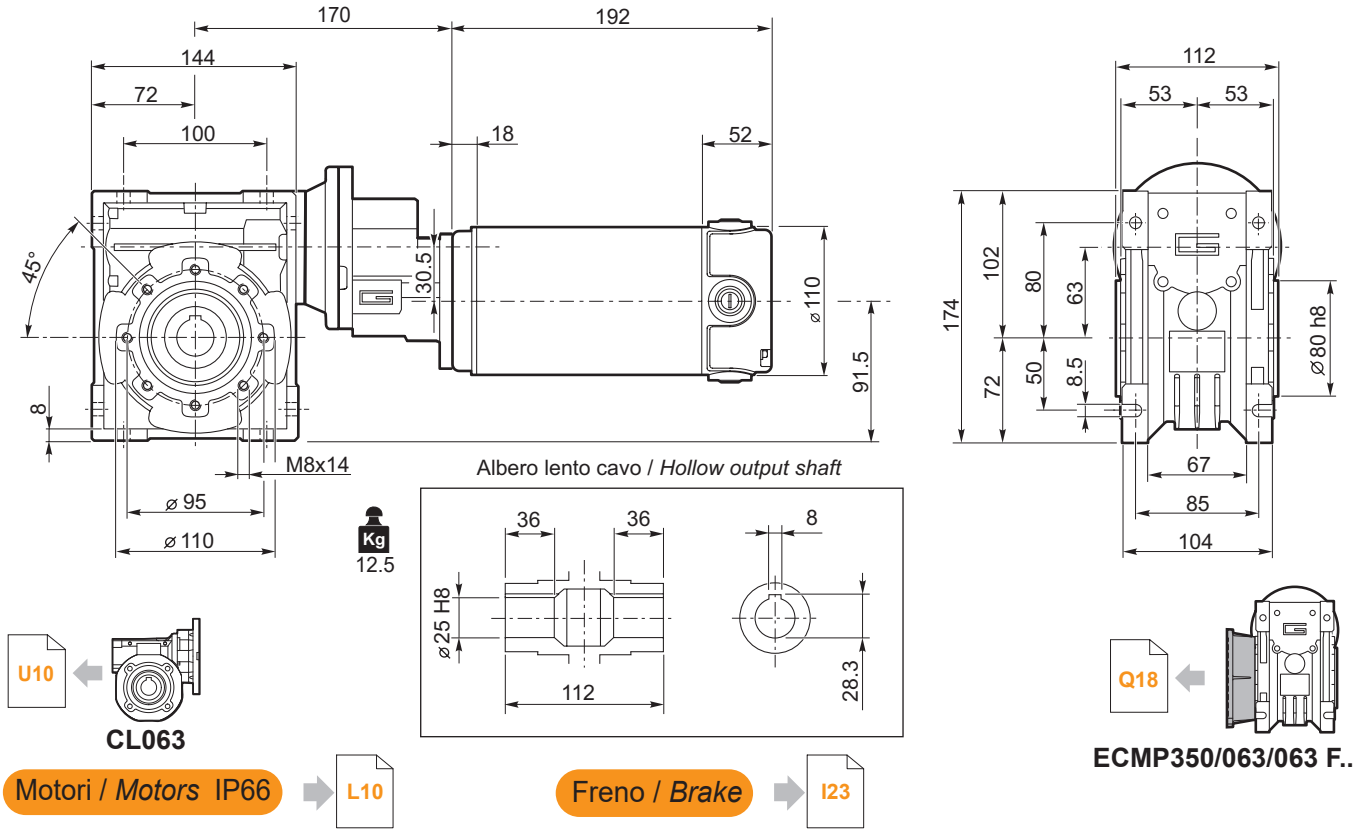

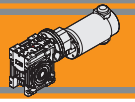

**Dimensioni**

**Dimensions**

**ECMP350/071/070 U**

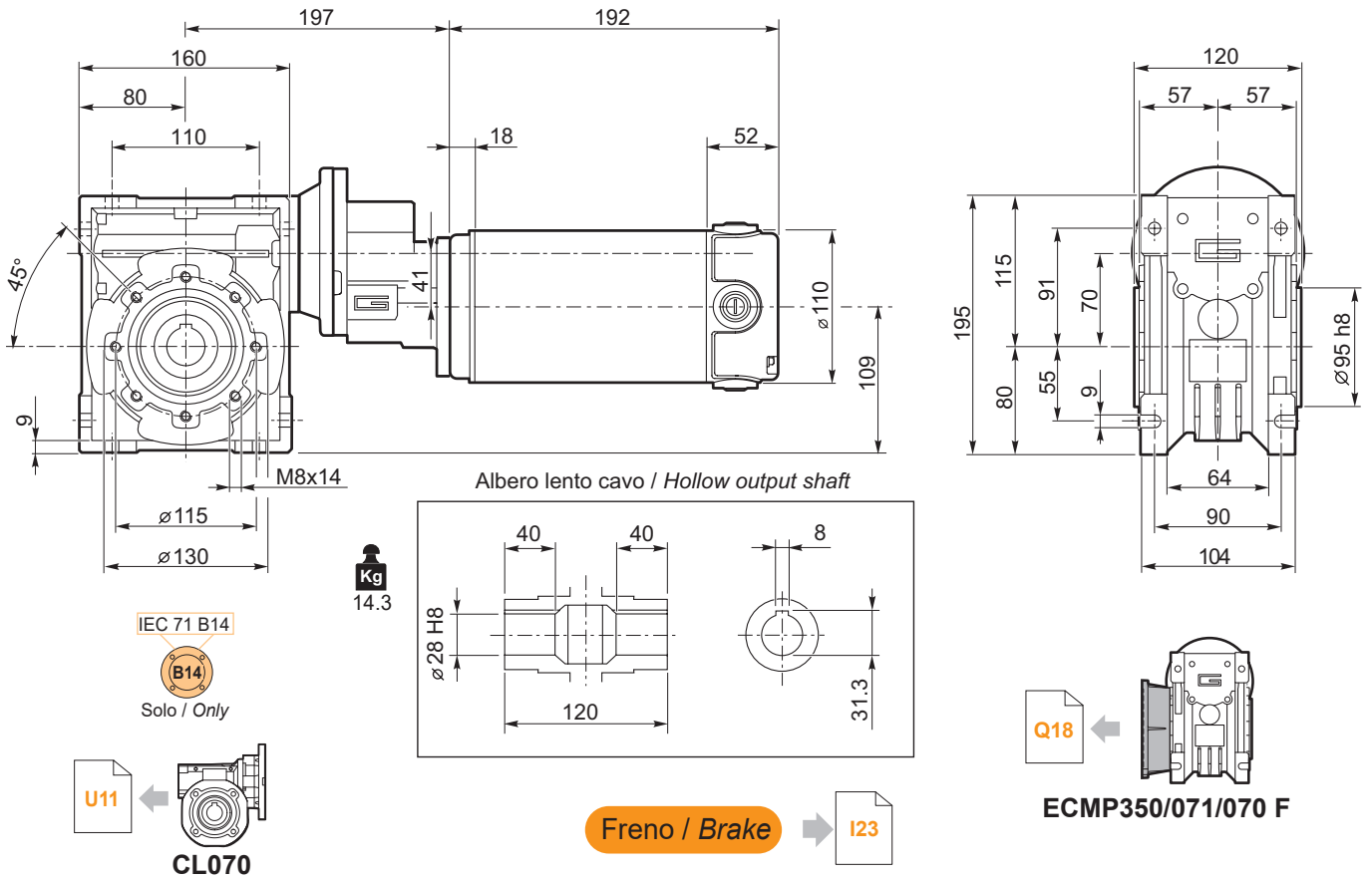

**ECMP350/071/075 U**

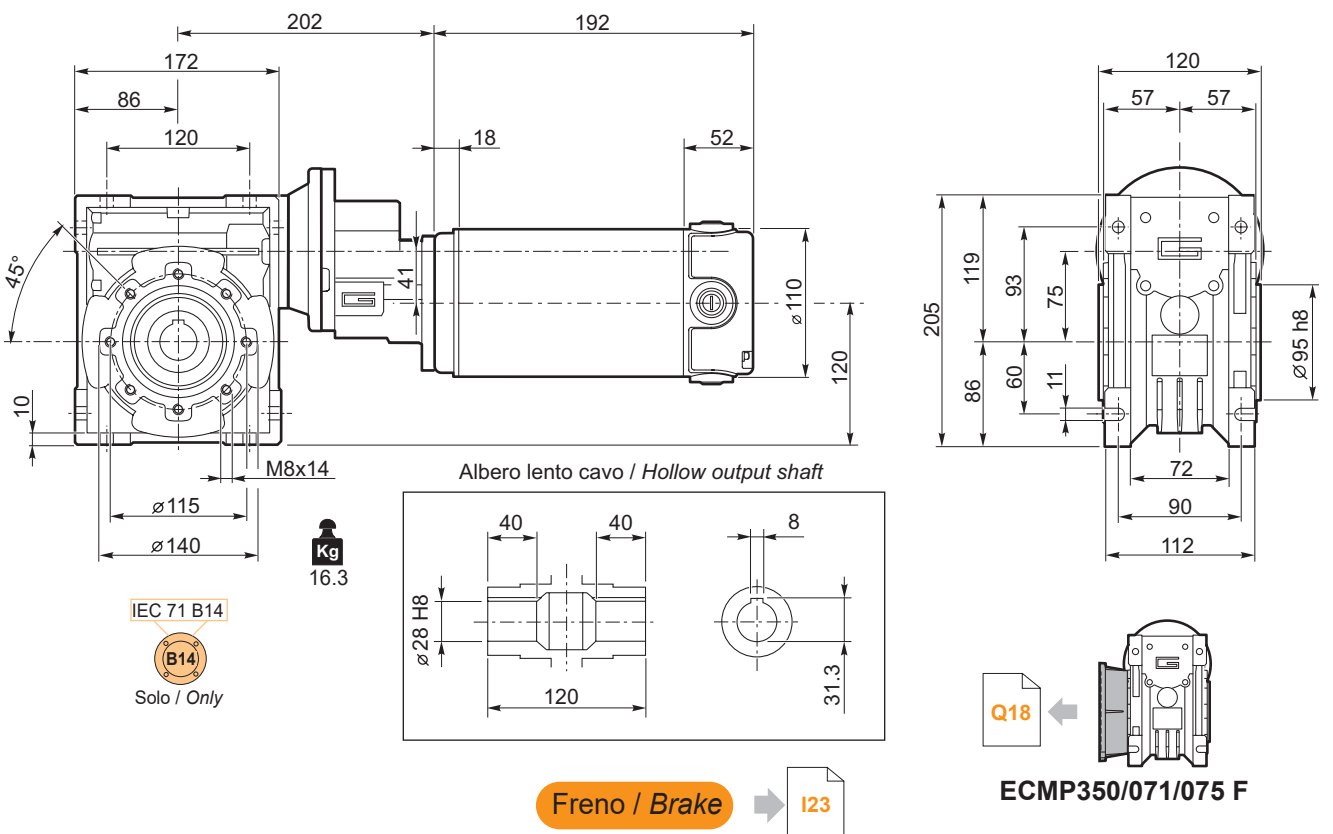

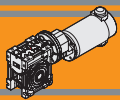

### Dimensioni

### Dimensions

#### ECMP600/071/050 U

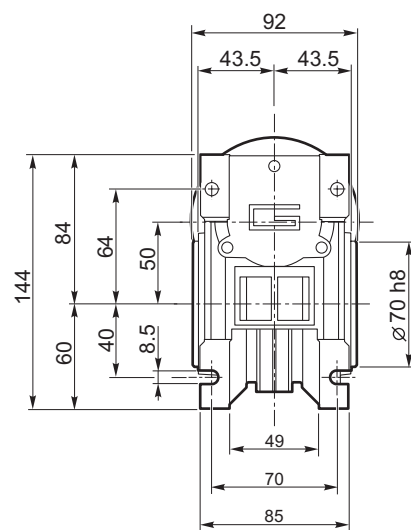
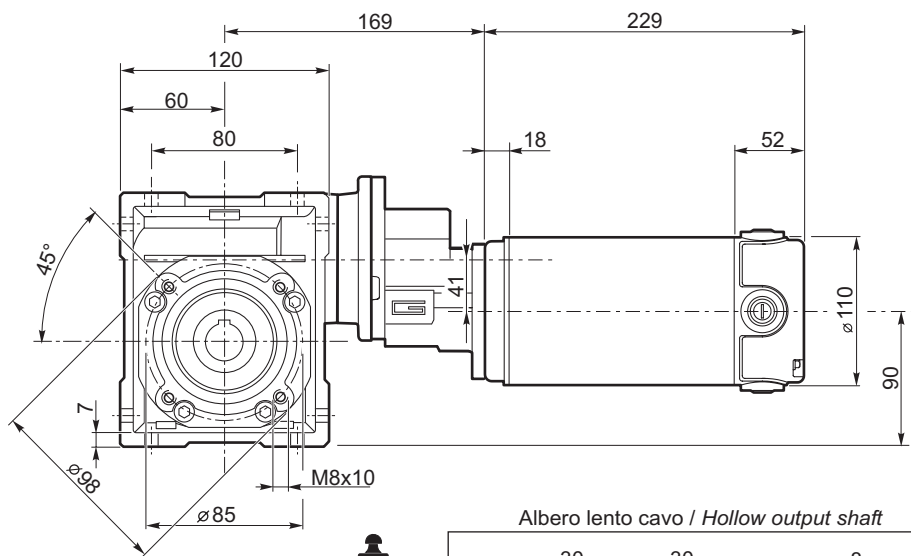

**Kg**  
12.3

Albero lento cavo / Hollow output shaft

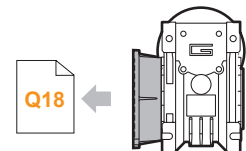
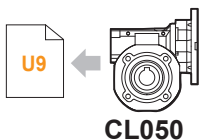
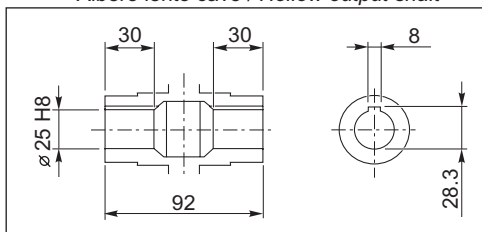

Motori / Motors IP66

**L12**

Freno / Brake

**I23**

#### ECMP600/071/063 U

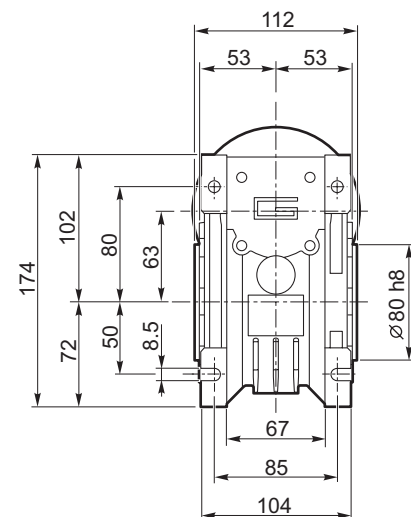
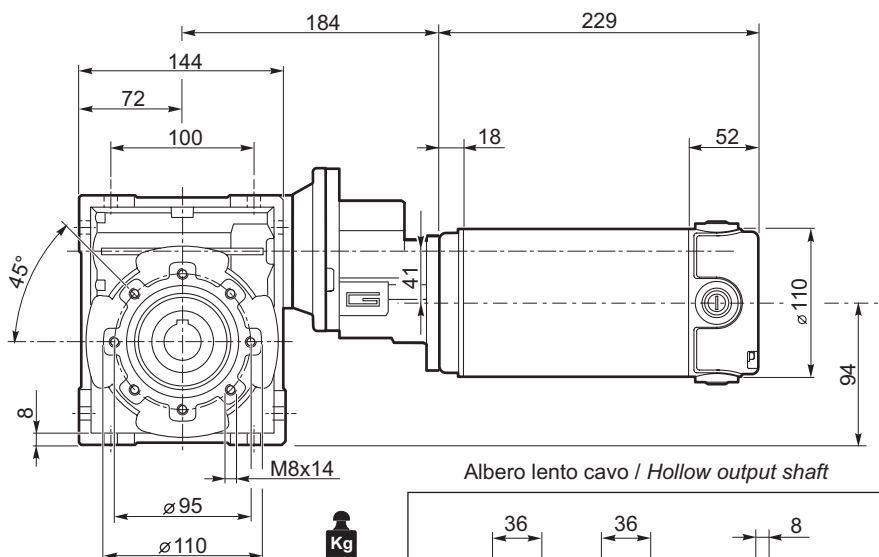

**Kg**  
15.0

Albero lento cavo / Hollow output shaft

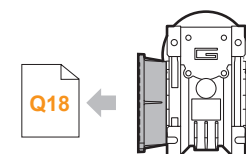
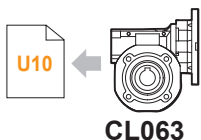
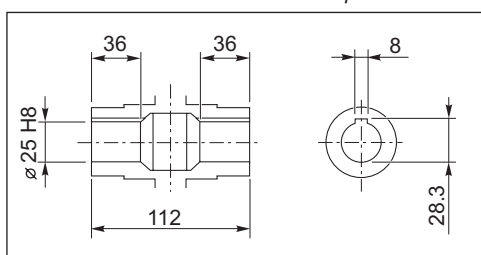

Motori / Motors IP66

**L12**

Freno / Brake

**I23**

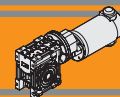

Dimensioni

Dimensions

ECMP600/071/070 U

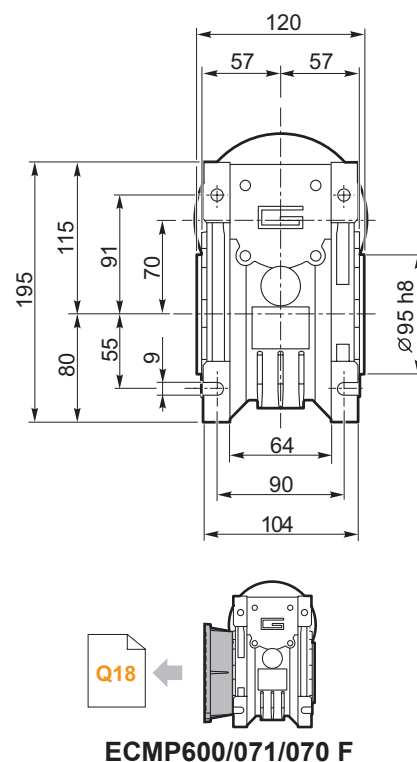
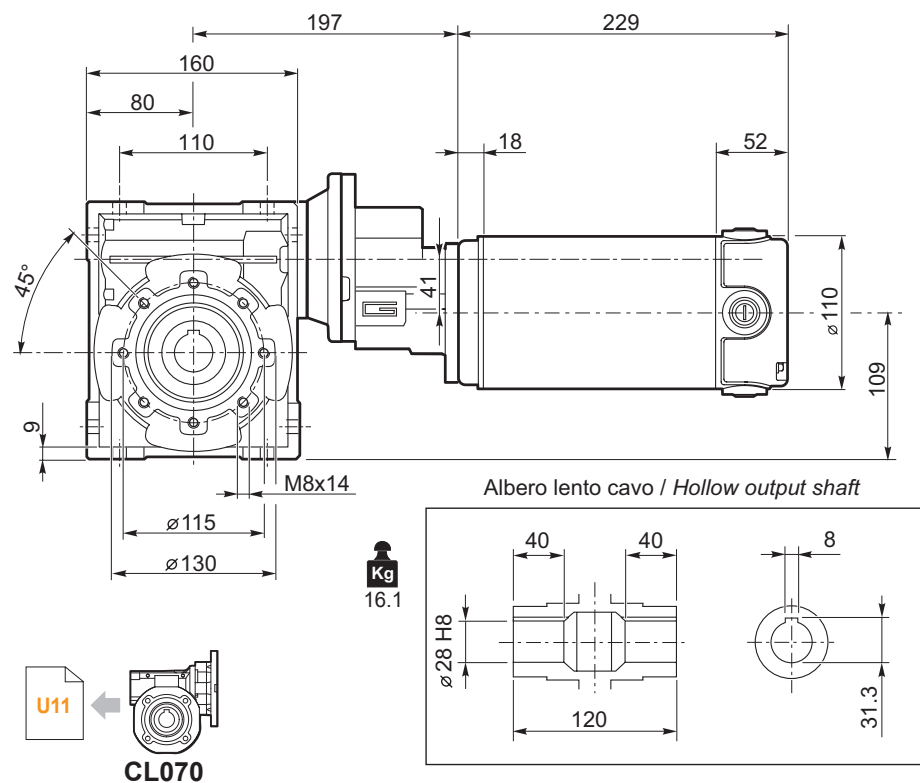

Motori / Motors IP66

L12

Freno / Brake

I23

ECMP600/071/075 U

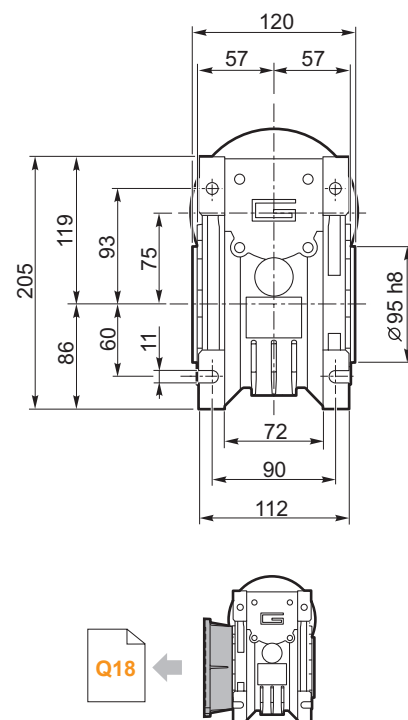
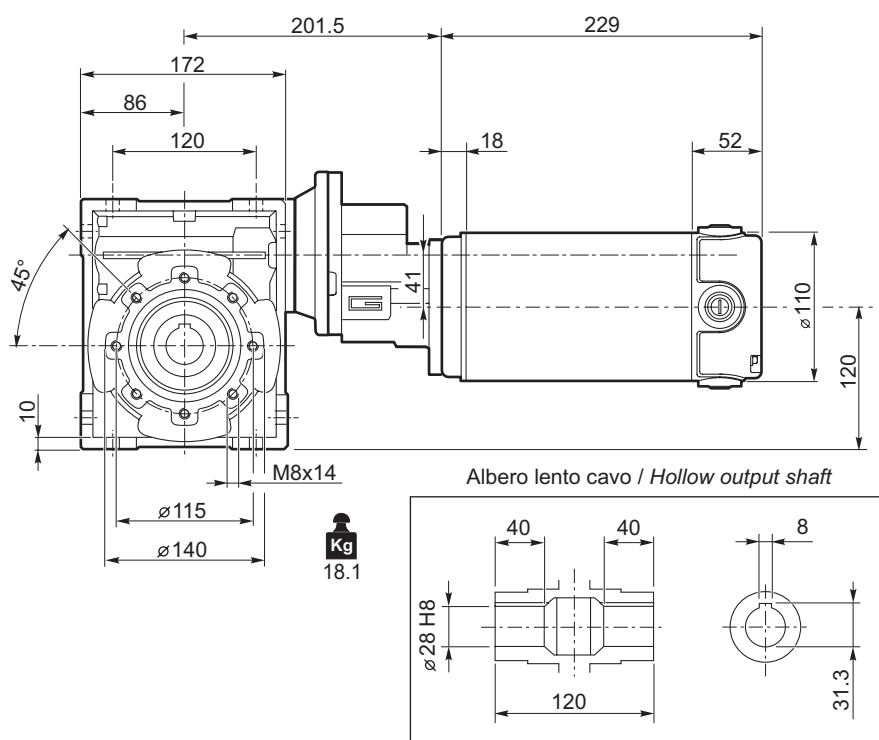

Motori / Motors IP66

L12

Freno / Brake

I23

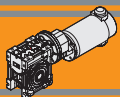

### Dimensioni

### Dimensions

#### EC100.24E EC180.24E

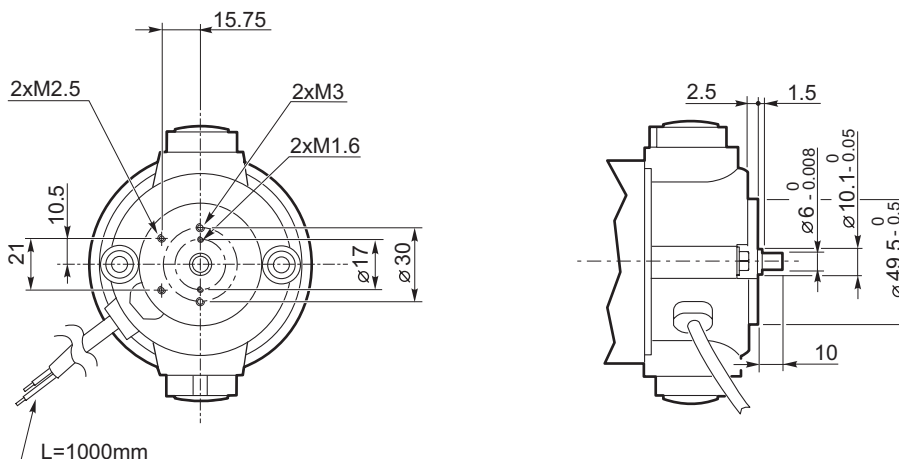

#### ECMP.../... F... Flange uscita / Output flanges

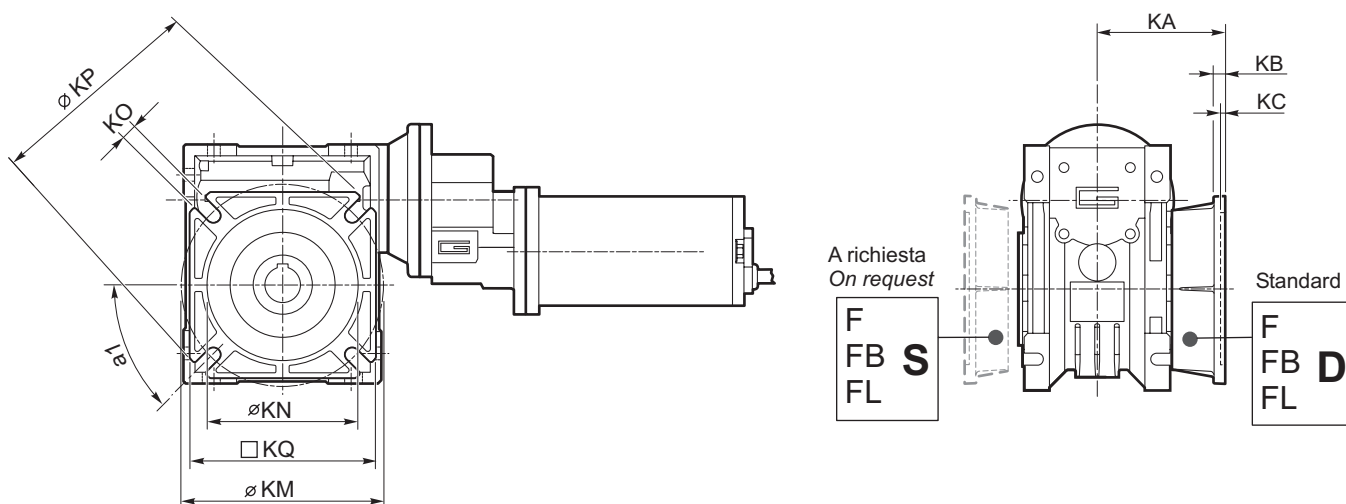

ECMP	ECMP..F								ECMP..FB								ECMP..FL								
	a1	KA	KB	KC	KM	KN <sub>H8</sub>	KO	KP	KQ	KA	KB	KC	KM	KN <sub>H8</sub>	KO	KP	KQ	KA	KB	KC	KM	KN <sub>H8</sub>	KO	KP	KQ
056/030	45°	54.5	6	4	68	50	6.5(n.4)	80	70	—	—	—	—	—	—	—	—	—	—	—	—	—	—	—	—
056/040 063/040	45°	67	7.5	4	80-95	60	9(n.4)	110	95	80	8.5	5	115-125	95	9.5(n.4)	140	112	97	7.5	4.5	80-95	60	9(n.4)	110	95
063/050 071/050	45°	90	9	5	90-110	70	11(n.4)	125	110	89	9	5	130-145	110	9.5(n.4)	160	132	120	9	5	90-110	70	11(n.4)	125	110
063/063 071/063	45°	82	10	6	150-160	115	11(n.4)	180	142	98	10	5	165-180	130	11(n.4)	200	160	112	10	6	150-160	115	11(n.4)	180	142
071/070	45°	107	13	6	165-180	130	14(n.4)	200	170	—	—	—	—	—	—	—	—	—	—	—	—	—	—	—	—
071/075	45°	111	13	6	165-180	130	14(n.4)	200	170	—	—	—	—	—	—	—	—	—	—	—	—	—	—	—	—

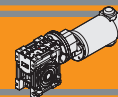

**Opzioni**

**Options**

**VS - Vite sporgente / Extended input shaft**

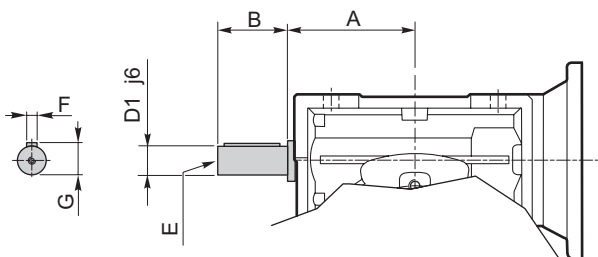

ECMP	A	B	D <sub>1</sub> j6	E	F	G
056/030	45	20	9	M4	3	10.2
056/040 063/040	53	23	11	M5	4	12.5
063/050	64	30	14	M6	5	16
063/063 071/063 080/063	75	40	19	M6	6	21.5
071/070	84	40	19	M6	6	21.5
071/075	90	50	24	M8	8	27

Costruito su richiesta  
Built on request

**Accessori**

**Accessories**

**SC - Safety cover**

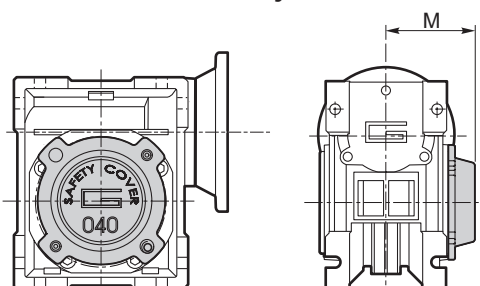

ECMP	M
... 030	47
... 040	54.5
... 050	62.5
... 063	73
... 070	75
... 075	79

**WD - Washdown cover**

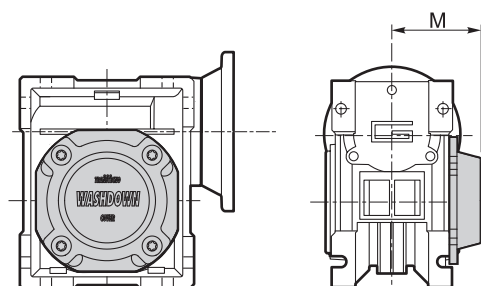

ECMP	M
... 030	48
... 040	55.5
... 050	63.5
... 063	71.5
... 070	76
... 075	80

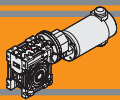

**Accessori**

**Accessories**

**Albero lento semplice e doppio**

CMP	d <sub>h7</sub>	B	B1	G1	L	L1	f	b1	t1
056/030	14	30	32.5	63	102	128	M6	5	16
056/040 063/040	18	40	43	78	128	164	M6	6	20.5
063/050	25	50	53.5	92	153	199	M10	8	28
063/063 071/063 080/063	25	50	53.5	112	173	219	M10	8	28
071/070	28	60	63.5	120	192	247	M10	8	31
071/075	28	60	63.5	120	192	247	M10	8	31

**Single and double output shaft**

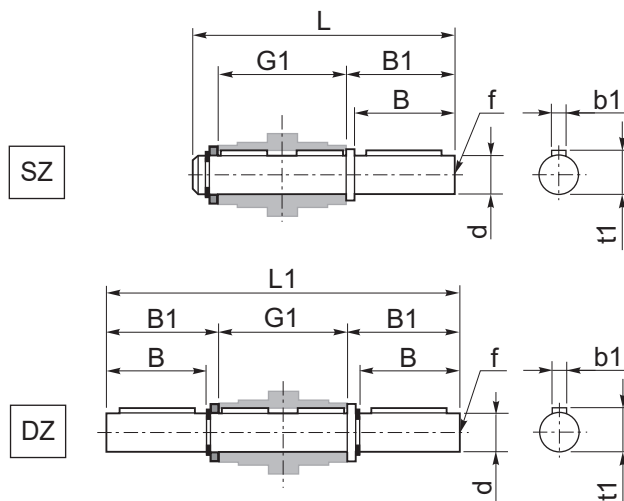

**Braccio di reazione**

CMP	K1	G	KG	KH	R
056/030	85	14	23	8	15
056/040 063/040	100	14	31	10	18
063/050	100	14	38	10	18
063/063 071/063 080/063	150	14	47.5	10	18
071/070	200	25	46.5	20	30
071/075	200	25	46.5	20	30

**Torque arm**

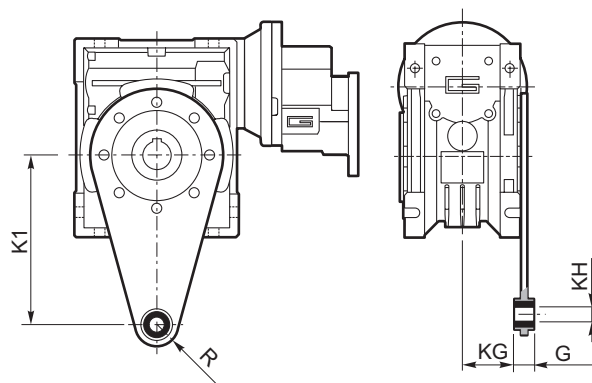



Ferrite

Motoriduttori CC a vite senza fine combinati  
**DC double reduction wormgearmotors**





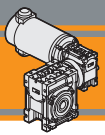

<b>Indice</b>	<b>Index</b>	Pag. Page
Caratteristiche tecniche	<i>Technical features</i>	<b>R2</b>
Designazione	<i>Classification</i>	<b>R2</b>
Simbologia	<i>Symbols</i>	<b>R3</b>
Esecuzioni di montaggio	<i>Mounting executions</i>	<b>R3</b>
Combinazioni rapporti	<i>Combination ratio</i>	<b>R3</b>
Lubrificazione	<i>Lubrication</i>	<b>R4</b>
Dati tecnici per servizio S2	<i>Technical data for S2 duty</i>	<b>R5</b>
Motori applicabili	<i>Motor adapters</i>	<b>R9</b>
Dimensioni	<i>Dimensions</i>	<b>R10</b>
Opzioni	<i>Options</i>	<b>R24</b>
Accessori	<i>Accessories</i>	<b>R24</b>

Questa sezione annulla e sostituisce ogni precedente edizione o revisione. Qualora questa sezione non Vi sia giunta in distribuzione controllata, l'aggiornamento dei dati ivi contenuto non è assicurato. **In tal caso la versione più aggiornata è disponibile sul nostro sito internet [www.transtecno.com](http://www.transtecno.com)**

*This section replaces any previous edition and revision. If you obtained this catalogue other than through controlled distribution channels, the most up to date content is not guaranteed. In this case the latest version is available on our web site [www.transtecno.com](http://www.transtecno.com)*

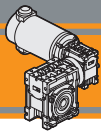

### Caratteristiche tecniche

### Technical features

Le caratteristiche principali dei motoriduttori CC a vite senza fine combinati a magneti permanenti in ferrite serie ECMM sono:

The main features of ECMM ferrite permanent magnets DC reduction wormgearmotors range are:

- Alimentazione in bassa tensione 12/24Vcc
- Possibilità di montaggio encoder
- Potenze motore disponibili da 100 a 800W S2
- Magneti in ferrite
- Carcassa in pressofusione di alluminio nelle grandezze 026, 030, 040, 050, 063, 075, 090 e 110. La grandezza 130 è costruita con carcassa in ghisa
- Lubrificazione permanente con olio sintetico

- Low voltage power supply 12/24Vdc
- Suitable for encoder assembly
- Motor power ratings available from 100 up to 800W S2
- Ferrite magnets
- Die cast aluminium housing on sizes 026, 030, 040, 050, 063, 075, 090 and 110. Cast iron housing on size 130
- Permanent synthetic oil long life lubrication

### Designazione

### Classification

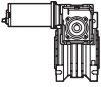
MOTORIDUTTORE / GEARMOTOR													
ECMM	100/026/026				U	150	SZDX	BRSX	90	B3	UB1	120	VS1
Tipo Type	Grandezza Size				Versione Version	Rapporto Ratio	Albero di uscita Output shaft	Braccio di reazione Torque arm	Angolo Angle	Pos. di montaggio Mounting position	Esecuzione di montaggio Mounting execution	Versione motore Motor version	Opzioni Options
	070/026/026	100/026/026	180/026/040	350/030/040	U F...	vedi tabelle  see tables	SZDX SZSX DZ	BRDX BRSX  *	0° 90° 180° 270°	B3 B8 B6 B7 V5 V6	UB1 UB2 US1 US2 UV1 UV2 UC1 UC2	120 240 24E	VS1** VS2**
	070/026/026 (D11)	100/026/026 (D11)	180/026/050	350/030/050									
	070/026/026 (D14)	100/026/026 (D14)	180/030/040	350/030/063									
	070/026/030	100/026/030	180/030/050	350/040/070									
	070/026/040	100/026/040	180/030/063	350/040/075									
	070/026/050	100/026/050	180/040/070	350/040/090									
	070/030/040	100/030/040	180/040/075	350/050/110									
	070/030/050	100/030/050	180/040/090	350/063/130									
	070/030/063	100/030/063	180/050/110										
	070/040/070	100/040/075											
	070/040/075	100/040/090	250/030/040	600/040/070									
	070/040/090		250/030/050	600/040/075									
			250/030/063	600/040/090									
			250/040/070	600/050/110									
			250/040/075	600/063/130									
		250/040/090											
		250/050/110											

\* NOTA: il braccio di reazione viene fornito smontato.  
NOTE: the torque arm will be supplied not assembled.

\*\* NOTA: Vite sporgente costruita su richiesta  
NOTE: Extended input shaft built on request

Accessori / Accessories  
SC - WD



Versione Riduttore  
Gearbox Version

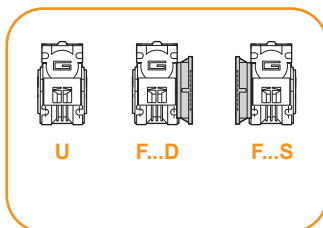

Albero di uscita  
Output shaft

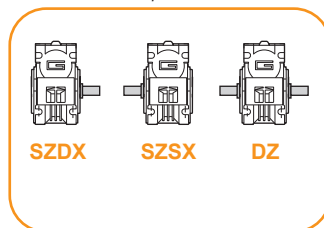

Braccio di reazione  
Torque arm \*

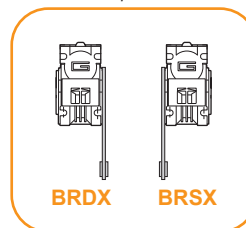

Angolo  
Angle

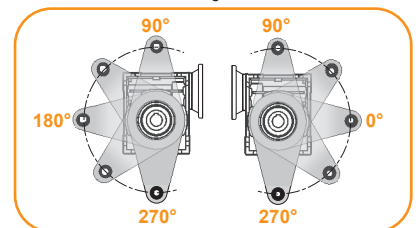

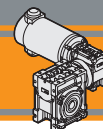

**Simbologia**

**Symbols**

$n_1$ [min <sup>-1</sup> ]	Velocità in ingresso / <i>Input speed</i>	$M_2$ [Nm]	Coppia in uscita in funzione di $P_1$ / <i>Output torque referred to <math>P_1</math></i>
$n_2$ [min <sup>-1</sup> ]	Velocità in uscita / <i>Output speed</i>	sf	Fattore di servizio / <i>Service factor</i>
i	Rapporto di riduzione / <i>Ratio</i>	$R_2$ [N]	Carico radiale ammissibile in uscita / <i>Permitted output radial load</i>
$P_1$ [kW]	Potenza in entrata / <i>Input power</i>	$A_2$ [N]	Carico assiale ammissibile in uscita / <i>Permitted output axial load</i>

**Esecuzioni di montaggio**

**Mounting executions**

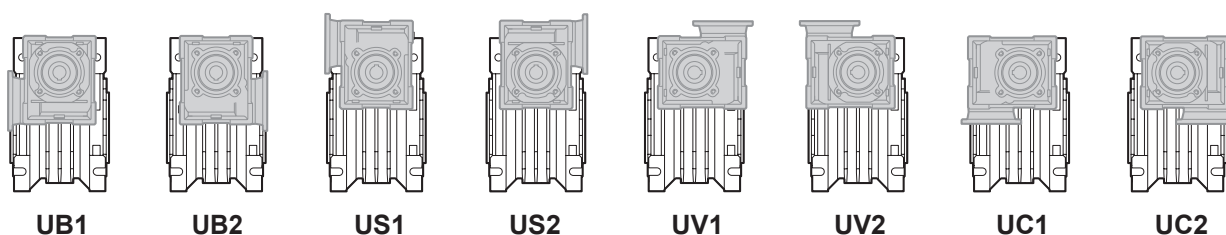

**Combinazioni rapporti**

**Combination ratio**

CMM 026/026 - CMM 026/030 - CMM 026/040 - CMM 026/050												
i (i <sub>1</sub> x i <sub>2</sub> )												
	150	225	300	450	600	900	1200	1500	1800	2400	3000	3600
i <sub>1</sub>	10	15	10	15	20	30	40	50	60	60	60	60
i <sub>2</sub>	15	15	30	30	30	30	30	30	30	40	50	60

CMM 030/040 - CMM 030/050 - CMM 030/063 - CMM 040/070 - CMM 040/075 - CMM 040/090 - CMM 050/110 - CMM 063/130																
i (i <sub>1</sub> x i <sub>2</sub> )																
	75	100	150	200	250	300	400	500	600	750	900	1200	1500	1800	2400	3000
i <sub>1</sub>	7.5	10	10	10	10	10	10	10	20	25	30	40	50	60	60	60
i <sub>2</sub>	10	10	15	20	25	30	40	50	30	30	30	30	30	30	40	50

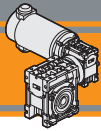

### Lubrificazione

Tutti i motoriduttori nelle taglie 26, 30, 40, 50, 63, 70, 75, 90, 110 sono forniti completi di lubrificante sintetico viscosità 320, pertanto possono essere installati in qualunque posizione di montaggio e non necessitano di manutenzione. Per la taglia 130 la lubrificazione dipende dalla posizione di montaggio

### Lubrication

Permanent synthetic oil long-life lubrication (viscosity grade 320) makes it possible to use the gearmotors size 26, 30, 40, 50, 63, 70, 75, 90, 110 in all mounting positions; for this reason they can be installed in any assembly position and do not require maintenance. Only for size 130, the lubrication depended of mounting positions

Quantità di olio (litri) / Oil quantity (litres)						
	M1 (B3)	M3 (B8)	M6 (B6)	M5 (B7)	M4 (V5)	M2 (V6)
<b>CM130</b>	4.5	3.3	3.5	3.5	4.5	3.3

Lubrificato a vita  
Life lubrication

### Posizioni di montaggio / Mounting positions

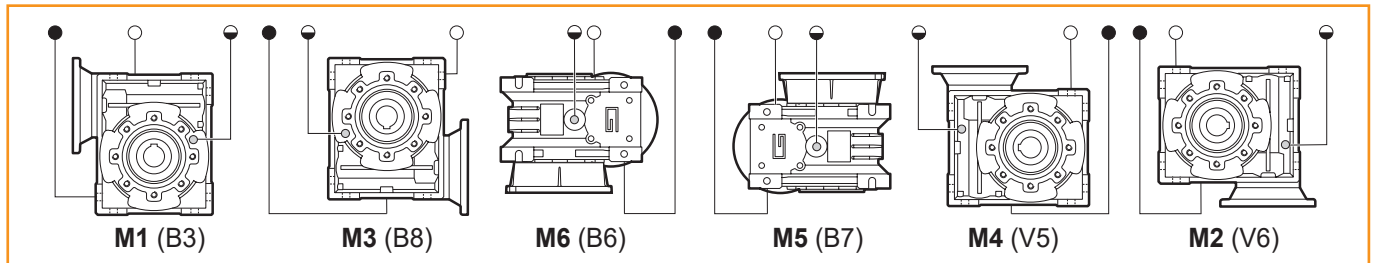





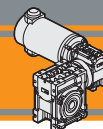







(standard)

- Sfiato e tappo di riempimento / Breather and filling plug
- ◐ Livello olio / Oil level plug
- Tappo di scarico / Oil drain plug



Dati tecnici per servizio S2

Technical data for S2 duty

$P_1$ [W]	$n_2$ [min <sup>-1</sup> ]	$M_2$ [Nm]	sf	i		Versione motore Motor version	$P_1$ [W]	$n_2$ [min <sup>-1</sup> ]	$M_2$ [Nm]	sf	i		Versione motore Motor version					
<b>100</b>							<b>100</b>											
(3000 min <sup>-1</sup> )	<b>20.0</b>	26	1.0	150		ECMM 070/026/026 12E/24E 120.66/240.66	(3000 min <sup>-1</sup> )	<b>40.0</b>	15	5.3	75		ECMM 070/030/040 12E/24E 120.66/240.66					
	<b>13.3</b>	33	0.8	225					<b>30.0</b>	20	4.1			100				
	<b>10.0</b>	34	0.8	300					<b>20.0</b>	28	3.1			150				
	<b>6.7</b>	34	0.8	450					<b>15.0</b>	36	2.0			200				
	<b>5.0</b>	34	0.8	600					<b>12.0</b>	43	1.5			250				
	<b>3.3</b>	34	0.8	900					<b>10.0</b>	46	1.9			300				
	<b>2.5</b>	34	0.8	1200					<b>7.5</b>	55	1.3			400				
	<b>2.0</b>	34	0.8	1500					<b>6.0</b>	63	1.1			500				
	<b>1.7</b>	34	0.8	1800					<b>5.0</b>	86	1.0			600				
	<b>1.3</b>	28	0.8	2400					<b>4.0</b>	103	0.8			750				
	<b>1.0</b>	25	0.8	3000					<b>3.3</b>	113	0.8			900				
	<b>0.8</b>	23	0.8	3600					<b>2.5</b>	93	0.8			1200				
	<b>20.0</b>	26	1.4	150				ECMM 070/026/030 12E/24E 120.66/240.66		<b>2.0</b>	113			0.8	1500			
	<b>13.3</b>	39	1.0	225					<b>1.7</b>	113	0.8	1800						
	<b>10.0</b>	43	0.9	300					<b>1.3</b>	93	0.8	2400						
	<b>6.7</b>	50	0.8	450					<b>1.0</b>	85	0.8	3000						
	<b>5.0</b>	50	0.8	600					<b>15.0</b>	36	3.7	200		ECMM 070/030/050 12E/24E 120.66/240.66				
	<b>3.3</b>	50	0.8	900					<b>12.0</b>	43	2.8	250						
	<b>2.5</b>	50	0.8	1200					<b>10.0</b>	46	3.4	300						
	<b>2.0</b>	50	0.8	1500					<b>7.5</b>	57	2.3	400						
	<b>1.7</b>	50	0.8	1800					<b>6.0</b>	64	1.9	500						
	<b>1.3</b>	43	0.8	2400					<b>5.0</b>	87	1.8	600						
	<b>1.0</b>	38	0.8	3000					<b>4.0</b>	105	1.5	750						
	<b>0.8</b>	34	0.8	3600					<b>3.3</b>	120	1.3	900						
	<b>20.0</b>	27	3.1	150		ECMM 070/026/040 12E/24E 120.66/240.66				<b>2.5</b>	146	0.9			1200			
	<b>13.3</b>	40	2.1	225					<b>2.0</b>	175	0.9	1500						
	<b>10.0</b>	45	1.9	300					<b>1.7</b>	201	0.8	1800						
	<b>6.7</b>	66	1.3	450					<b>1.3</b>	169	0.8	2400						
	<b>5.0</b>	85	1.0	600					<b>1.0</b>	156	0.8	3000						
	<b>3.3</b>	113	0.8	900					<b>7.5</b>	58	4.4	400		ECMM 070/030/063 12E/24E 120.66/240.66				
	<b>2.5</b>	113	0.8	1200					<b>6.0</b>	67	3.4	500						
	<b>2.0</b>	113	0.8	1500					<b>5.0</b>	90	2.7	600						
	<b>1.7</b>	113	0.8	1800					<b>4.0</b>	109	2.4	750						
	<b>1.3</b>	93	0.8	2400					<b>3.3</b>	124	2.4	900						
	<b>1.0</b>	85	0.8	3000					<b>2.5</b>	149	1.7	1200						
	<b>0.8</b>	78	0.8	3600					<b>2.0</b>	181	1.4	1500						
	<b>20.0</b>	28	4.1	150				ECMM 070/026/050 12E/24E 120.66/240.66		<b>1.7</b>	208	1.2			1800			
	<b>13.3</b>	42	2.8	225					<b>1.3</b>	249	1.0	2400						
	<b>10.0</b>	46	3.4	300					<b>1.0</b>	288	0.8	3000						
	<b>6.7</b>	67	2.3	450					<b>2.5</b>	155	2.4	1200				ECMM 070/040/070 12E/24E 120.66/240.66		
	<b>5.0</b>	86	1.8	600					<b>2.0</b>	193	2.3	1500						
	<b>3.3</b>	118	1.3	900					<b>1.7</b>	221	2.0	1800						
	<b>2.5</b>	147	1.1	1200					<b>1.3</b>	265	1.4	2400						
	<b>2.0</b>	173	0.9	1500					<b>1.0</b>	307	1.1	3000						
	<b>1.7</b>	194	0.8	1800					<b>2.5</b>	158	2.9	1200		ECMM 070/040/075 12E/24E 120.66/240.66				
	<b>1.3</b>	169	0.8	2400					<b>2.0</b>	193	2.8	1500						
	<b>1.0</b>	156	0.8	3000					<b>1.7</b>	221	2.3	1800						
	<b>0.8</b>	141	0.8	3600					<b>1.3</b>	270	1.7	2400						
									<b>1.0</b>	307	1.3	3000						
							<b>1.3</b>	285	2.3	2400		ECMM 070/040/090 12E/24E 120.66/240.66						
							<b>1.0</b>	331	2.0	3000								

N.B.  
Verificare sempre che la coppia M2 utilizzata non ecceda il valore indicato nelle caselle in grigio  
N.B.  
Please check that the output torque M2 does not exceed the value in the grey areas

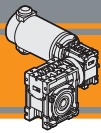

**NOTA:** per servizio continuo o altamente intermittente, contattare il servizio tecnico

**NOTE:** for continuous or highly intermittent duty, please contact our technical service



### Dati tecnici per servizio S2

### Technical data for S2 duty

$P_1$ [W]	$n_2$ [min <sup>-1</sup> ]	$M_2$ [Nm]	sf	i		Versione motore Motor version	$P_1$ [W]	$n_2$ [min <sup>-1</sup> ]	$M_2$ [Nm]	sf	i		Versione motore Motor version
<b>140</b>							<b>250</b>						
(3000 min <sup>-1</sup> )	<b>20.0</b>	37	1.0	150	<b>ECMM 100/026/030</b>	120/240/24E 120.66/240.66	(3000 min <sup>-1</sup> )	<b>20.0</b>	70	1.2	150	<b>ECMM 180/026/040</b>	120/240 120.66/240.66
	<b>20.0</b>	38	2.2	150	<b>ECMM 100/026/040</b>	120/240/24E 120.66/240.66		<b>20.0</b>	73	1.6	150	<b>ECMM 180/026/050</b>	120/240 120.66/240.66
	<b>13.3</b>	55	1.5	225				<b>13.3</b>	108	1.1	225		
	<b>10.0</b>	63	1.4	300				<b>10.0</b>	118	1.4	300		
	<b>6.7</b>	92	0.9	450				<b>6.7</b>	173	0.9	450		
	<b>20.0</b>	39	2.9	150	<b>ECMM 100/026/050</b>	120/240/24E 120.66/240.66		<b>40.0</b>	40	2.1	75	<b>ECMM 180/030/040</b>	120/240/24E 120.66/240.66
	<b>13.3</b>	58	2.0	225				<b>30.0</b>	52	1.6	100		
	<b>10.0</b>	64	2.5	300				<b>20.0</b>	71	1.2	150		
	<b>6.7</b>	93	1.7	450				<b>40.0</b>	40	2.9	75	<b>ECMM 180/030/050</b>	120/240/24E 120.66/240.66
	<b>5.0</b>	120	1.3	600				<b>30.0</b>	52	2.3	100		
	<b>3.3</b>	164	1.0	900				<b>20.0</b>	74	2.2	150		
	<b>40.0</b>	21	3.8	75	<b>ECMM 100/030/040</b>	120/240/24E 120.66/240.66		<b>15.0</b>	94	1.5	200		
	<b>30.0</b>	28	2.9	100				<b>12.0</b>	110	1.1	250		
	<b>20.0</b>	38	2.2	150				<b>10.0</b>	120	1.4	300		
	<b>15.0</b>	50	1.4	200				<b>7.5</b>	146	0.9	400		
	<b>12.0</b>	59	1.1	250				<b>15.0</b>	92	2.3	200	<b>ECMM 180/030/063</b>	120/240/24E 120.66/240.66
	<b>10.0</b>	63	1.4	300				<b>12.0</b>	108	2.1	250		
	<b>7.5</b>	77	0.9	400				<b>10.0</b>	124	2.3	300		
	<b>15.0</b>	50	2.6	200	<b>ECMM 100/030/050</b>	120/240/24E 120.66/240.66		<b>7.5</b>	149	1.8	400		
	<b>12.0</b>	59	2.0	250				<b>6.0</b>	172	1.4	500		
	<b>10.0</b>	64	2.4	300				<b>5.0</b>	233	1.1	600		
	<b>7.5</b>	78	1.7	400				<b>4.0</b>	281	1.0	750		
	<b>6.0</b>	89	1.4	500				<b>3.3</b>	320	1.0	900		
	<b>5.0</b>	121	1.3	600				<b>12.0</b>	113	3.0	250	<b>ECMM 180/040/070</b>	120/240/24E* 120.66/240.66
	<b>4.0</b>	146	1.1	750				<b>10.0</b>	125	3.6	300		
	<b>3.3</b>	166	0.9	900				<b>7.5</b>	150	2.5	400		
	<b>6.0</b>	92	2.4	500	<b>ECMM 100/030/063</b>	120/240/24E 120.66/240.66		<b>6.0</b>	174	1.9	500		
	<b>5.0</b>	125	1.9	600				<b>5.0</b>	239	1.9	600		
	<b>4.0</b>	151	1.7	750				<b>4.0</b>	288	1.6	750		
	<b>3.3</b>	172	1.7	900				<b>3.3</b>	333	1.4	900		
	<b>2.5</b>	206	1.2	1200				<b>2.5</b>	399	1.0	1200		
	<b>2.0</b>	252	1.0	1500				<b>2.0</b>	497	0.9	1500		
	<b>3.3</b>	179	2.4	900	<b>ECMM 100/040/070</b>	120/240/24E* 120.66/240.66		<b>12.0</b>	113	3.6	250	<b>ECMM 180/040/075</b>	120/240* 24E 120.66/240.66
	<b>2.5</b>	215	1.7	1200				<b>10.0</b>	125	4.4	300		
	<b>2.0</b>	267	1.6	1500				<b>7.5</b>	153	3.1	400		
	<b>1.7</b>	307	1.4	1800				<b>6.0</b>	174	2.3	500		
	<b>1.3</b>	368	1.0	2400				<b>5.0</b>	239	2.3	600		
	<b>3.3</b>	179	3.0	900	<b>ECMM 100/040/075</b>	120/240/24E* 120.66/240.66		<b>4.0</b>	288	1.8	750		
	<b>2.5</b>	219	2.1	1200				<b>3.3</b>	333	1.7	900		
	<b>2.0</b>	267	2.0	1500				<b>2.5</b>	407	1.2	1200		
	<b>1.7</b>	307	1.6	1800				<b>2.0</b>	497	1.1	1500		
	<b>1.3</b>	375	1.2	2400				<b>1.7</b>	570	0.9	1800		
	<b>1.0</b>	426	0.9	3000				<b>5.0</b>	251	2.3	600	<b>ECMM 180/040/090</b>	120/240* 24E 120.66/240.66
	<b>1.7</b>	322	1.6	1800	<b>ECMM 100/040/090</b>	120/240/24E* 120.66/240.66		<b>4.0</b>	302	1.8	750		
	<b>1.3</b>	395	1.6	2400				<b>3.3</b>	349	2.1	900		
	<b>1.0</b>	460	1.4	3000				<b>2.5</b>	429	1.9	1200		
								<b>2.0</b>	522	1.2	1500		
								<b>1.7</b>	599	0.9	1800		
								<b>1.3</b>	735	0.9	2400		
								<b>3.3</b>	359	3.6	900	<b>ECMM 180/050/110</b>	120/240/24E* IEC 63B14
								<b>2.5</b>	457	3.2	1200		
								<b>2.0</b>	545	2.0	1500		
								<b>1.7</b>	627	1.6	1800		
								<b>1.3</b>	796	1.6	2400		
								<b>1.0</b>	947	1.4	3000		



Solo / Only

**NOTA:** per servizio continuo o altamente intermittente, contattare il servizio tecnico



**NOTE:** for continuous or highly intermittent duty, please contact our technical service

\*: Motore inclinato con portaspazzole a 45°  
Motor assembly with brush holder inclined 45°



Dati tecnici per servizio S2

Technical data for S2 duty

$P_1$ [W]	$n_2$ [min <sup>-1</sup> ]	$M_2$ [Nm]	sf	i		Versione motore Motor version	$P_1$ [W]	$n_2$ [min <sup>-1</sup> ]	$M_2$ [Nm]	sf	i		Versione motore Motor version		
<b>350</b>							<b>500</b>								
(3000 min <sup>-1</sup> )	40.0	55	1.5	75		ECMM 250/030/040	120/240	(3000 min <sup>-1</sup> )	40.0	78	1.1	75		ECMM 350/030/040	120/240
	30.0	72	1.2	100			120.66/240.66		30.0	103	1.2	100			120.66/240.66
	20.0	100	0.9	150					20.0	146	1.1	150			
	40.0	56	2.0	75		ECMM 250/030/050	120/240		40.0	79	1.4	75		ECMM 350/030/050	120/240
	30.0	73	1.7	100			120.66/240.66		30.0	103	1.2	100			120.66/240.66
	20.0	104	1.6	150					20.0	146	1.1	150			
	15.0	131	1.1	200		ECMM 250/030/063			40.0	80	1.4	75		ECMM 350/030/063	120/240
	12.0	154	0.8	250					30.0	104	1.2	100			120.66/240.66
	10.0	168	1.0	300					20.0	144	1.2	150			
	30.0	74	1.7	100		ECMM 250/030/063	120/240		15.0	181	1.2	200		ECMM 350/040/070	120/240
	20.0	103	1.7	150			120.66/240.66		12.0	213	1.1	250			120.66/240.66
	15.0	129	1.7	200					10.0	243	1.2	300			
	12.0	152	1.5	250		ECMM 250/040/070			7.5	292	0.9	400		ECMM 350/040/070	120/240
	10.0	173	1.7	300					20.0	148	2.4	150			120.66/240.66
	7.5	208	1.3	400					15.0	186	2.1	200			
	6.0	241	1.0	500		ECMM 250/040/070	120/240		12.0	222	1.5	250		ECMM 350/040/075	120/240
	15.0	133	3.0	200			120.66/240.66		10.0	246	1.8	300			120.66/240.66
	12.0	158	2.2	250					7.5	295	1.3	400			
	10.0	175	2.6	300		ECMM 250/040/075			6.0	341	1.0	500		ECMM 350/040/075	120/240
	7.5	210	1.8	400					20.0	150	2.4	150			120.66/240.66
	6.0	244	1.4	500					15.0	188	2.4	200			
	5.0	335	1.4	600		ECMM 250/040/075	120/240		12.0	222	1.8	250		ECMM 350/040/090	120/240
	4.0	403	1.1	750			120.66/240.66		10.0	246	2.2	300			120.66/240.66
	3.3	466	1.0	900					7.5	300	1.5	400			
	15.0	134	3.4	200		ECMM 250/040/090	120/240		6.0	341	1.2	500		ECMM 350/050/110	120/240
	12.0	158	2.6	250			120.66/240.66		5.0	469	1.2	600			120.66/240.66
	10.0	175	3.1	300					4.0	565	0.9	750			
	7.5	214	2.2	400		ECMM 250/040/090			12.0	236	2.4	250		ECMM 350/063/130	120/240
	6.0	244	1.7	500					10.0	258	2.4	300			120.66/240.66
	5.0	335	1.6	600					7.5	317	2.4	400			
	4.0	403	1.3	750		ECMM 250/050/110			6.0	369	1.8	500		ECMM 350/063/130	120/240
	3.3	489	1.5	900					5.0	493	1.2	600			120.66/240.66
	2.5	600	1.4	1200					4.0	593	0.9	750			
	6.0	286	4.5	500		ECMM 250/050/110	120/240		3.3	685	1.0	900		ECMM 350/063/130	120/240
	5.0	361	2.9	600			120.66/240.66		2.5	841	1.0	1200			120.66/240.66
	4.0	441	2.2	750					6.0	401	3.1	500			120/240
	3.3	503	2.6	900		ECMM 250/050/110			5.0	506	2.1	600		ECMM 350/063/130	120.66/240.66
	2.5	639	2.3	1200					4.0	618	1.6	750			120.66/240.66
	2.0	763	1.4	1500					3.3	705	1.8	900			120.66/240.66
	1.7	877	1.1	1800		ECMM 250/050/110			2.5	896	1.6	1200		ECMM 350/063/130	120/240
	1.3	1115	1.1	2400					2.0	1070	1.0	1500			120.66/240.66
	1.0	1325	1.0	3000					4.0	645	2.6	750			120/240
						ECMM 250/050/110			3.3	737	2.3	900		ECMM 350/063/130	120/240
									2.5	938	1.7	1200			120.66/240.66
									2.0	1135	1.5	1500			120.66/240.66
						ECMM 250/050/110			1.7	1306	1.3	1800		ECMM 350/063/130	120/240
									1.3	1662	0.9	2400			120.66/240.66
									1.0	1875	0.8	3000			120.66/240.66

N.B.  
Verificare sempre che la coppia M2 utilizzata non ecceda il valore indicato nelle caselle in grigio  
N.B.  
Please check that the output torque M2 does not exceed the value in the grey areas

NOTA: per servizio continuo o altamente intermittente, contattare il servizio tecnico  
NOTE: for continuous or highly intermittent duty, please contact our technical service



Solo / Only

ECMM

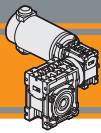

### Dati tecnici per servizio S2

### Technical data for S2 duty

$P_1$ [W]	$n_2$ [min <sup>-1</sup> ]	$M_2$ [Nm]	sf	i		Versione motore Motor version
<b>800</b>						
(3000 min <sup>-1</sup> )	<b>40.0</b>	132	1.8	75	<b>ECMM 600/040/070</b>	120/240
	<b>30.0</b>	172	1.5	100		120.66/240.66
	<b>20.0</b>	239	1.5	150		
	<b>15.0</b>	301	1.3	200		
	<b>12.0</b>	359	0.9	250		
	<b>10.0</b>	398	1.1	300		
	<b>40.0</b>	132	1.8	75	<b>ECMM 600/040/075</b>	120/240
	<b>30.0</b>	172	1.5	100		120.66/240.66
	<b>20.0</b>	242	1.5	150		
	<b>15.0</b>	305	1.5	200		
	<b>12.0</b>	359	1.1	250		
	<b>10.0</b>	398	1.4	300		
	<b>7.5</b>	486	1.0	400		
	<b>20.0</b>	249	1.5	150	<b>ECMM 600/040/090</b>	120/240
	<b>15.0</b>	318	1.5	200		120.66/240.66
	<b>12.0</b>	381	1.5	250		
	<b>10.0</b>	418	1.5	300		
	<b>7.5</b>	513	1.5	400		
	<b>6.0</b>	597	1.2	500		
	<b>5.0</b>	732	0.8	600		
	<b>12.0</b>	402	2.7	250	<b>ECMM 600/050/110</b>	120/240
	<b>10.0</b>	429	2.7	300		120.66/240.66
	<b>7.5</b>	545	2.6	400		
	<b>6.0</b>	648	2.0	500		
	<b>5.0</b>	819	1.3	600		
	<b>4.0</b>	1000	1.0	750		
	<b>3.3</b>	1141	1.1	900		
	<b>2.5</b>	1450	1.0	1200		
	<b>7.5</b>	563	2.8	400	<b>ECMM 600/063/130</b>	120/240
	<b>6.0</b>	682	2.2	500		120.66/240.66
	<b>5.0</b>	845	2.0	600		
	<b>4.0</b>	1044	1.6	750		
	<b>3.3</b>	1192	1.4	900		
	<b>2.5</b>	1517	1.1	1200		
	<b>2.0</b>	1836	0.9	1500		

N.B.  
Verificare sempre che la coppia  $M_2$  utilizzata non ecceda il valore indicato nelle caselle in grigio

N.B.  
Please check that the output torque  $M_2$  does not exceed the value in the grey areas

**NOTA:** per servizio continuo o altamente intermittente, contattare il servizio tecnico

**NOTE:** for continuous or highly intermittent duty, please contact our technical service

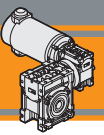

**Motori applicabili**

**Motor adapters**

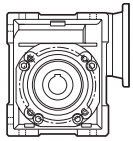
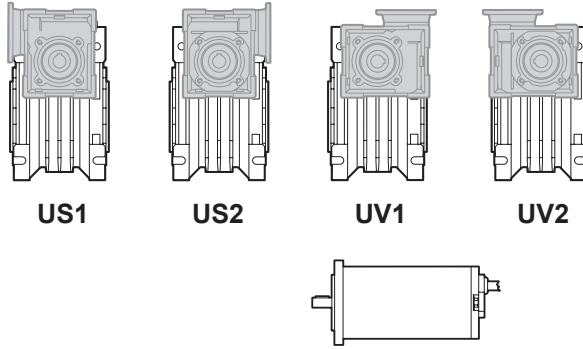

		EC			
		070.12E 070.24E	100.120 100.240	100.24E	180.120 180.240
<b>CMM</b>	<b>026/026</b>	150 - 3600	150 - 3600	150 - 3600	150 - 3600

150 - 3600      Rapporti di riduzione i  
Ratio i

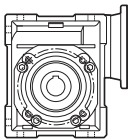
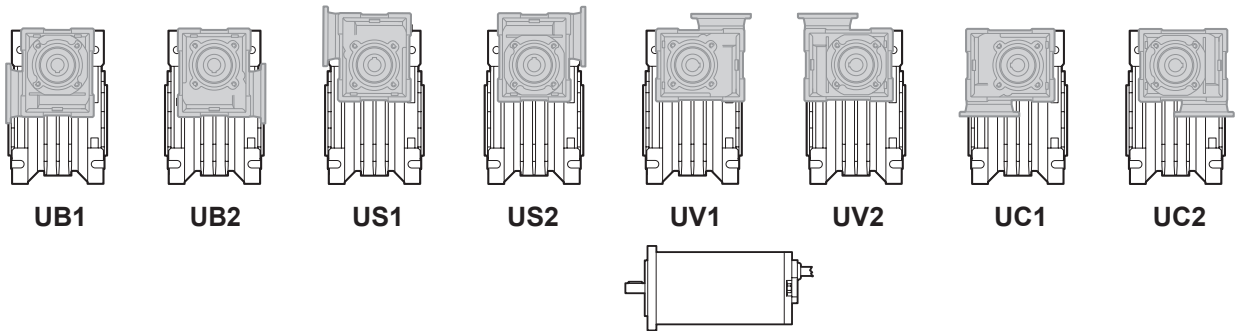

		EC							
		070.12E 070.24E	100.120 100.240	100.24E	180.120 180.240	180.24E	250.120 250.240	350.120 350.240	600.120 600.240
<b>CMM</b>	<b>026/030</b>	150 - 3600	150 - 3600	150 - 3600	150 - 3600				
	<b>026/040</b>	150 - 3600	150 - 3600	150 - 3600	150 - 3600				
	<b>026/050</b>	150 - 3600	150 - 3600	150 - 3600	150 - 3600				
	<b>030/040</b>	75 - 3000	75 - 3000	75 - 3000	75 - 3000	75 - 1500	75 - 1500	75 - 1500	
	<b>030/050</b>	75 - 3000	75 - 3000	75 - 3000	75 - 3000	75 - 1500	75 - 1500	75 - 1500	
	<b>030/063</b>	75 - 3000	75 - 3000	75 - 3000	75 - 3000	75 - 1500	75 - 1500	75 - 1500	
	<b>040/070</b>	75 - 3000	75 - 3000	75 - 3000	75 - 3000	75 - 3000	75 - 3000	75 - 3000	75 - 1200
	<b>040/075</b>	75 - 3000	75 - 3000	75 - 3000	75 - 3000	75 - 3000	75 - 3000	75 - 3000	75 - 1200
	<b>040/090</b>	75 - 3000	75 - 3000	75 - 3000	75 - 3000	75 - 3000	75 - 3000	75 - 3000	75 - 1200
	<b>050/110</b>				1200 - 3000 <sup>(1)</sup>	75 - 3000	75 - 3000	75 - 3000	75 - 3000
<b>063/130</b>							75 - 3000 <sup>(2)</sup>	75 - 3000	

150 - 3600      Rapporti di riduzione i      (1): Solo IEC 63 B14      (2): Solo IEC 71 B14  
Ratio i      63 B14 only      71 B14 only

**ECMM**

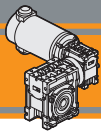

### Dimensioni

### Dimensions

CMM..U - CMM..F..																	
	A	C	D <sub>H8</sub>	E	F	G	G1	H	H1	I	I1	K	L	M	N <sub>h8</sub>	N1	N2
026/026 (D11)	45	70	11	83	22	47.5	50	35	34	26	26	34	42	55	45	22.5	21
026/026			12														
026/026 (D14)			14														
026/030	54	80	14	97	32	47.5	63	40	34	30	26	44	56	65	55	29	21
026/040	70	100	18	121.5	43	47.5	78	50	34	40	26	60	71	75	60	36.5	21
026/050	80	120	25	144	49	47.5	92	60	34	50	26	70	85	85	70	43.5	21
030/040	70	100	18	121.5	43	55	78	50	40	40	30	60	71	75	60	36.5	29
030/050	80	120	25	144	49	55	92	60	40	50	30	70	85	85	70	43.5	29
030/063	100	144	25	174	67	55	112	72	40	63	30	85	104	95	80	53	29
040/070	110	160	28	195	64	70	120	80	50	70	40	90	104	115	95	57	35.5
040/075	120	172	28	205	72	70	120	86	50	75	40	90	112	115	95	57	36.5
040/090	140	208	35	238	74	70	140	103	50	90	40	100	130	130	110	67	36.5

CMM..U - CMM..F..														
	O	P	Q	R	R1	S	T	V	Z	KE	a	b	t	Kg (!)
026/026 (D11)	6	—	37	49	49	5	15	21	76	7	—	4	12.8	3.3
026/026												4	13.8	
026/026 (D14)												5	16.2	
026/030	6.5	75	44	57	49	5.5	22	27	81	M6x10(n.4)	90°	5	16.3	4.1
026/040	6.5	87	55	71.5	49	6.5	26	35	91.5	M6x8(n.4)	45°	6	20.8	5.2
026/050	8.5	98	64	84	49	7	30	40	100.5	M8x10(n.4)	45°	8	28.3	6.7
030/040	6.5	87	55	71.5	57	6.5	26	35	122	M6x8(n.4)	45°	6	20.8	5.6
030/050	8.5	98	64	84	57	7	30	40	132	M8x10(n.4)	45°	8	28.3	6.7
030/063	8.5	110	80	102	57	8	36	50	145	M8x14(n.8)	45°	8	28.3	8.7
040/070	9	130	91	115	71.5	9	40	55	160	M8x14(n.8)	45°	8	31.3	12.7
040/075	11	140	93	119	71.5	10	40	60	165	M8x14(n.8)	45°	8	31.3	13.7
040/090	13	160	102	135	71.5	11	45	70	182	M10x18(n.8)	45°	10	38.3	17.3

(!) **Nota:** Il peso in kg si riferisce al motoriduttore ECMM 070 /...  
**Note:** The weight in kg is referred to the gearmotor ECMM 070 /...



Dimensioni

Dimensions

ECMM070/...U

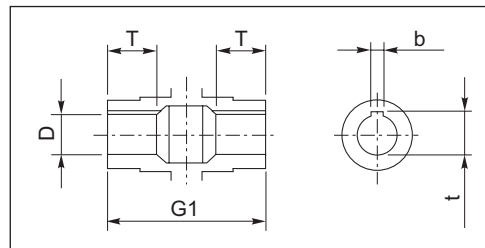
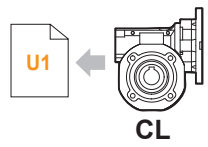
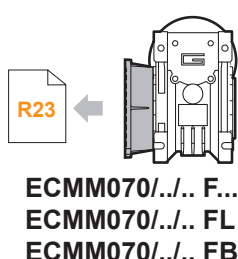
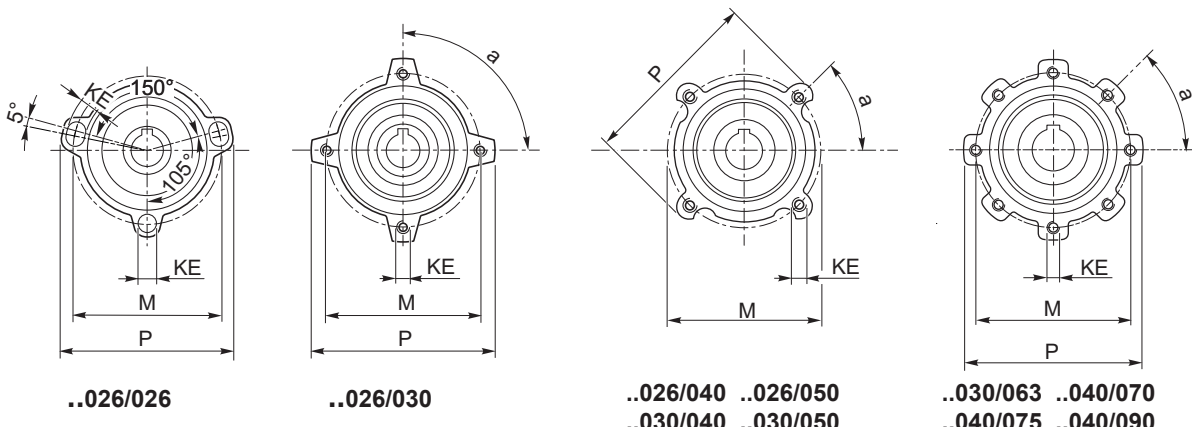
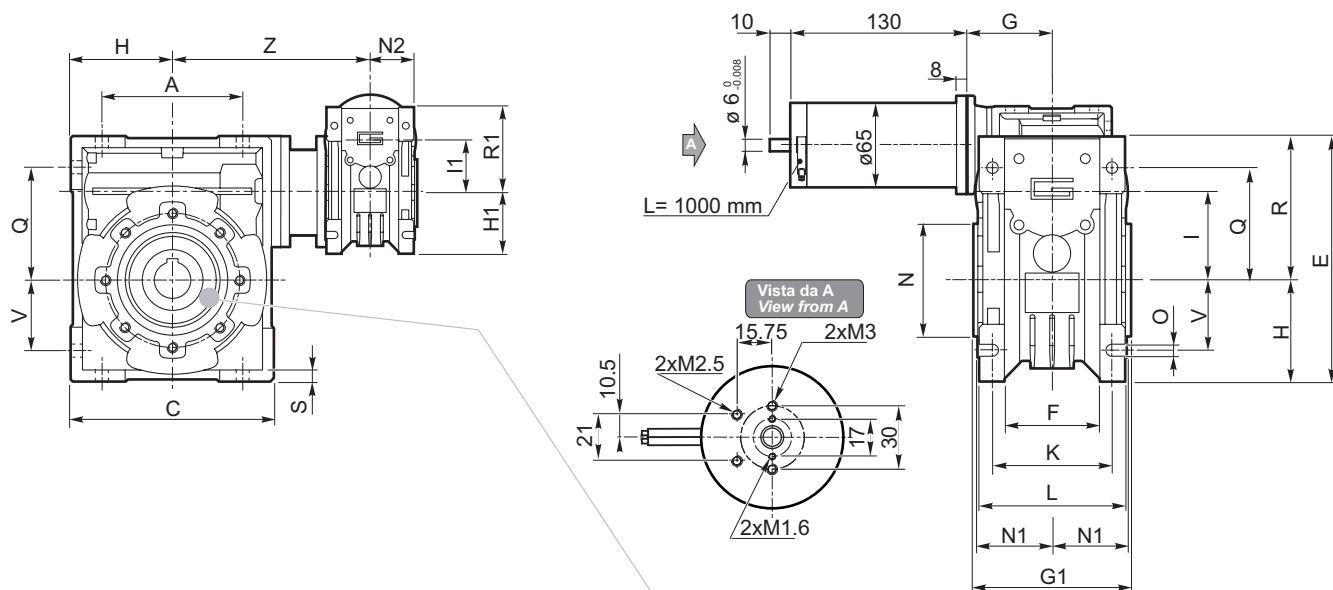

Albero lento cavo / Hollow output shaft

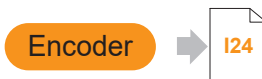

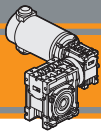

### Dimensioni

### Dimensions

CMM..U - CMM..F...																	
	A	C	D <sub>H8</sub>	E	F	G	G1	H	H1	I	I1	K	L	M	N <sub>H8</sub>	N1	N2
026/026 (D11)	45	70	11	83	22	47.5	50	35	34	26	26	34	42	55	45	22.5	21
026/026			12														
026/026 (D14)			14														
026/030	54	80	14	97	32	47.5	63	40	34	30	26	44	56	65	55	29	21
026/040	70	100	18	121.5	43	47.5	78	50	34	40	26	60	71	75	60	36.5	21
026/050	80	120	25	144	49	47.5	92	60	34	50	26	70	85	85	70	43.5	21
030/040	70	100	18	121.5	43	55	78	50	40	40	30	60	71	75	60	36.5	29
030/050	80	120	25	144	49	55	92	60	40	50	30	70	85	85	70	43.5	29
030/063	100	144	25	174	67	55	112	72	40	63	30	85	104	95	80	53	29
040/070 *	110	160	28	195	64	70	120	80	50	70	40	90	104	115	95	57	35.5
040/075 *	120	172	28	205	72	70	120	86	50	75	40	90	112	115	95	57	36.5
040/090 *	140	208	35	238	74	70	140	103	50	90	40	100	130	130	110	67	36.5

CMM..U - CMM..F...															
	O	P	Q	R	R1	S	T	V	Z	KE	a	b	t	Kg (!)	
026/026 (D11)	6	—	37	49	49	5	15	21	76	7	—	4	12.8	3.3	
026/026												4	13.8		
026/026 (D14)												5	16.2		
026/030	6.5	75	44	57	49	5.5	22	27	81	M6x10(n.4)	90°	5	16.3	5.1	
026/040	6.5	87	55	71.5	49	6.5	26	35	91.5	M6x8(n.4)	45°	6	20.8	6.2	
026/050	8.5	98	64	84	49	7	30	40	100.5	M8x10(n.4)	45°	8	28.3	7.7	
030/040	6.5	87	55	71.5	57	6.5	26	35	122	M6x8(n.4)	45°	6	20.8	6.6	
030/050	8.5	98	64	84	57	7	30	40	132	M8x10(n.4)	45°	8	28.3	7.7	
030/063	8.5	110	80	102	57	8	36	50	145	M8x14(n.8)	45°	8	28.3	9.7	
040/070 *	9	130	91	115	71.5	9	40	55	160	M8x14(n.8)	45°	8	31.3	13.7	
040/075 *	11	140	93	119	71.5	10	40	60	165	M8x14(n.8)	45°	8	31.3	14.7	
040/090 *	13	160	102	135	71.5	11	45	70	182	M10x18(n.8)	45°	10	38.3	18.3	

(!) **Nota:** Il peso in kg si riferisce al motoriduttore ECMM 100 /...

**Note:** The weight in kg is referred to the gearmotor ECMM 100 /...

\*: Motore inclinato con portaspazzole a 45°

Motor assembly with brush holder inclined 45°

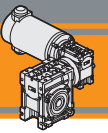

Dimensioni

Dimensions

**ECMM100/...U**

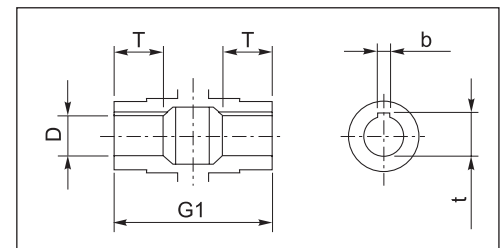
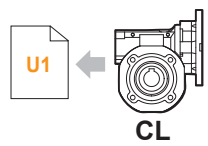
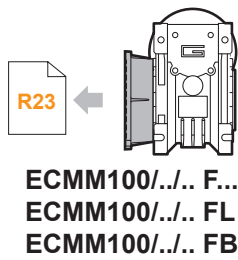
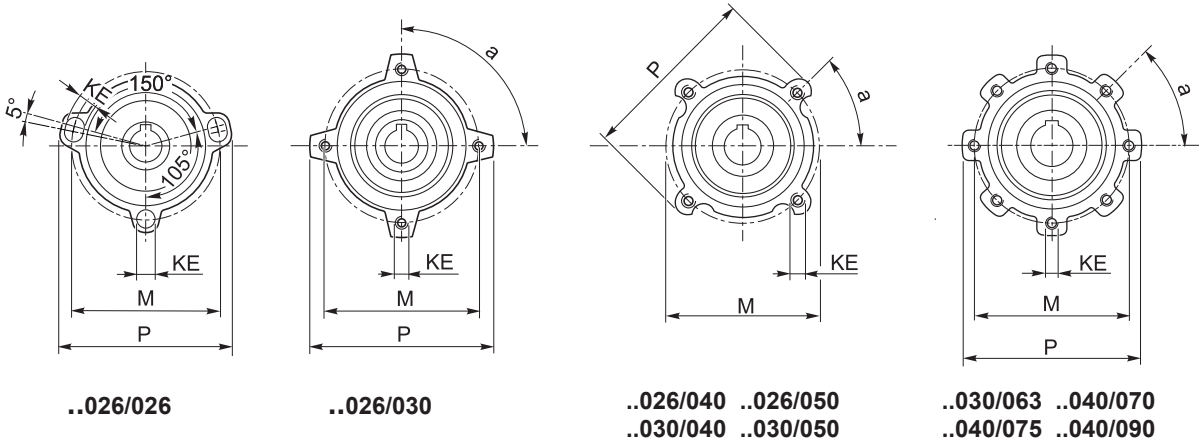
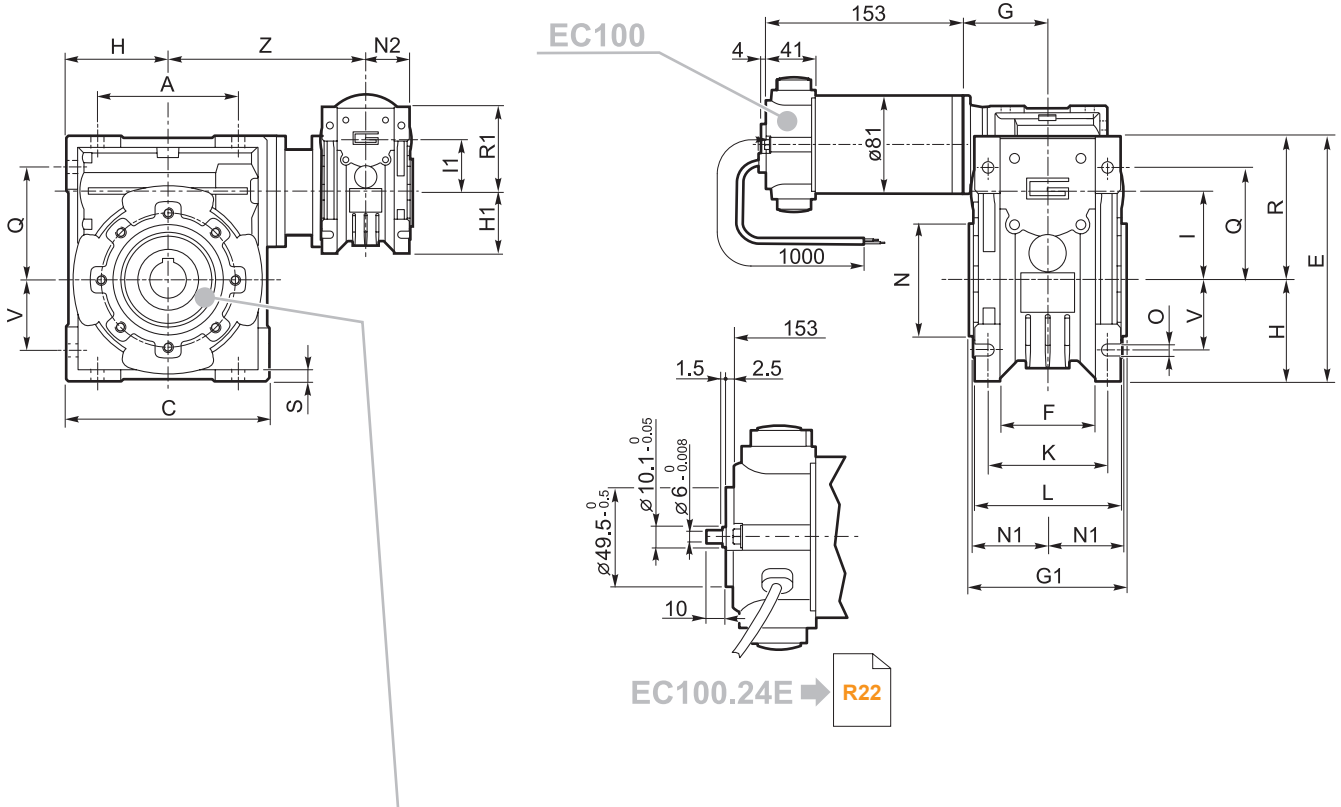

Albero lento cavo / Hollow output shaft

Motori / Motors IP66 → L4

Freno / Brake → I23

Encoder → I24

**ECMM**

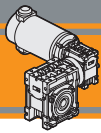

### Dimensioni

### Dimensions

CMM..U - CMM..F - CMM..FB - CMM..FL																	
	A	C	D <sub>H8</sub>	E	F	G	G1	H	H1	I	I1	K	L	M	N <sub>H8</sub>	N1	N2
026/040 <sup>(1)</sup>	70	100	18	121.5	43	47.5	78	50	34	40	26	60	71	75	60	36.5	21
026/050 <sup>(1)</sup>	80	120	25	144	49	47.5	92	60	34	50	26	70	85	85	70	43.5	21
030/040	70	100	18	121.5	43	55	78	50	40	40	30	60	71	75	60	36.5	29
030/050	80	120	25	144	49	55	92	60	40	50	30	70	85	85	70	43.5	29
030/063	100	144	25	174	67	55	112	72	40	63	30	85	104	95	80	53	29
040/070 *	110	160	28	195	64	70	120	80	50	70	40	90	104	115	95	57	35.5
040/075 *	120	172	28	205	72	70	120	86	50	75	40	90	112	115	95	57	36.5
040/090 *	140	208	35	238	74	70	140	103	50	90	40	100	130	130	110	67	36.5
050/110 <sup>(2)</sup>	170	252.5	42	295	—	80	155	127.5	60	110	50	115	144	165	130	74	43.5

CMM..U - CMM..F - CMM..FB - CMM..FL														
	O	P	Q	R	R1	S	T	V	Z	KE	a	b	t	Kg (!)
026/040 <sup>(1)</sup>	6.5	87	55	71.5	49	6.5	26	35	91.5	M6x8(n.4)	45°	6	20.8	6.9
026/050 <sup>(1)</sup>	8.5	98	64	84	49	7	30	40	100.5	M8x10(n.4)	45°	8	28.3	8.4
030/040	6.5	87	55	71.5	57	6.5	26	35	122	M6x8(n.4)	45°	6	20.8	7.3
030/050	8.5	98	64	84	57	7	30	40	132	M8x10(n.4)	45°	8	28.3	8.4
030/063	8.5	110	80	102	57	8	36	50	145	M8x14(n.8)	45°	8	28.3	10.4
040/070 *	9	130	91	115	71.5	9	40	55	160	M8x14(n.8)	45°	8	31.3	14.4
040/075 *	11	140	93	119	71.5	10	40	60	165	M8x14(n.8)	45°	8	31.3	15.4
040/090 *	13	160	102	135	71.5	11	45	70	182	M10x18(n.8)	45°	10	38.3	19
050/110 <sup>(2)</sup>	14	200	125	167.5	84	14	50	85	225	M10x18(n.8)	45°	12	45.3	33.6

(!) **Nota:** Il peso in kg si riferisce al motoriduttore ECMM 180 /...  
**Note:** The weight in kg is referred to the gearmotor ECMM 180 /...

\*: Motore inclinato con portaspazzole a 45°  
 Motor assembly with brush holder inclined 45°

(1): Versione 24E non disponibile  
 Version 24E not available

(2): Solo IEC 63 B14. Versione IP66 non disponibile  
 IEC 63 B14 only. IP66 version not available

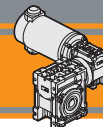

**Dimensioni**

**Dimensions**

**ECMM180/.../..U**

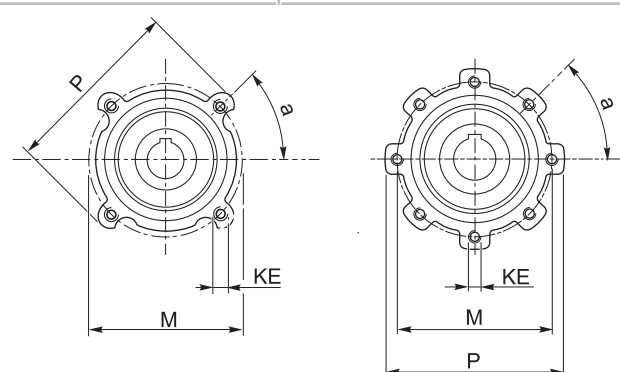
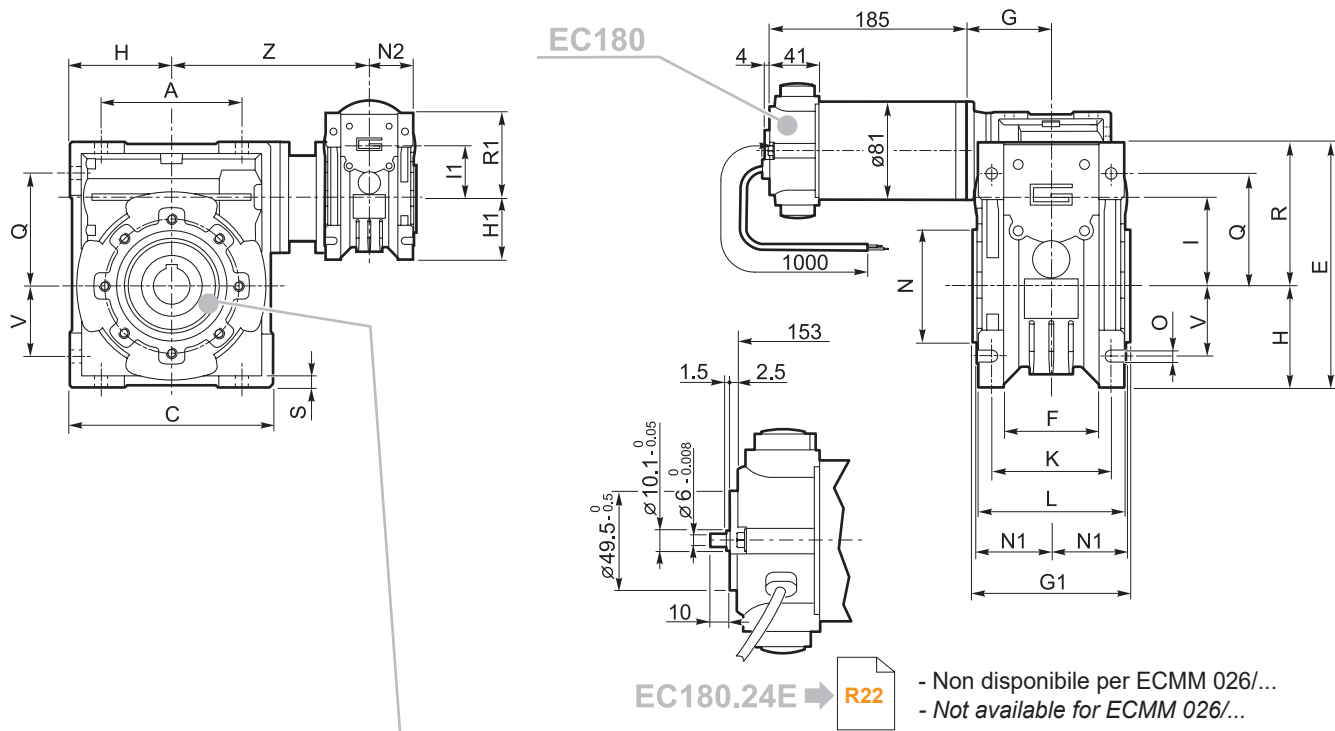

- |           |           |           |           |
|-----------|-----------|-----------|-----------|
| ..026/040 | ..026/050 | ..030/063 | ..040/070 |
| ..030/040 | ..030/050 | ..040/075 | ..040/090 |
|           |           | ..050/110 |           |

**R23** →

**ECMM180/.../.. F**  
**ECMM180/.../.. FL**  
**ECMM180/.../.. FB**

**U1** →

**CL**

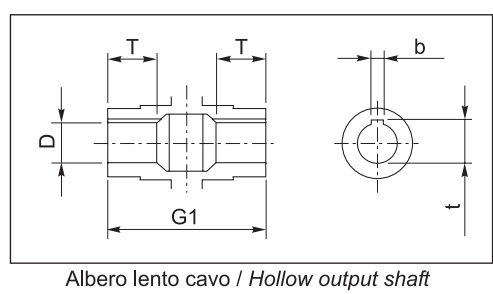

**Motori / Motors IP66** → **L6**

- Non disponibile per ECMM 180/050/110
- Not available for ECMM 180/050/110

**Freno / Brake** → **I23**

**Encoder** → **I24**

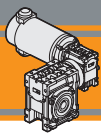

### Dimensioni

### Dimensions

CMM..U - CMM..F - CMM..FB - CMM..FL																	
	A	C	D <sub>H8</sub>	E	F	G	G1	H	H1	I	I1	K	L	M	N <sub>H8</sub>	N1	N2
030/040	70	100	18	121.5	43	55	78	50	40	40	30	60	71	75	60	36.5	29
030/050	80	120	25	144	49	55	92	60	40	50	30	70	85	85	70	43.5	29
030/063	100	144	25	174	67	55	112	72	40	63	30	85	104	95	80	53	29
040/070	110	160	28	195	64	70	120	80	50	70	40	90	104	115	95	57	35.5
040/075	120	172	28	205	72	70	120	86	50	75	40	90	112	115	95	57	36.5
040/090	140	208	35	238	74	70	140	103	50	90	40	100	130	130	110	67	36.5
050/110	170	252.5	42	295	—	80	155	127.5	60	110	50	115	144	165	130	74	43.5

CMM..U - CMM..F - CMM..FB - CMM..FL														
	O	P	Q	R	R1	S	T	V	Z	KE	a	b	t	Kg (!)
030/040	6.5	87	55	71.5	57	6.5	26	35	122	M6x8(n.4)	45°	6	20.8	8.2
030/050	8.5	98	64	84	57	7	30	40	132	M8x10(n.4)	45°	8	28.3	9.3
030/063	8.5	110	80	102	57	8	36	50	145	M8x14(n.8)	45°	8	28.3	11.3
040/070	9	130	91	115	71.5	9	40	55	160	M8x14(n.8)	45°	8	31.3	15.3
040/075	11	140	93	119	71.5	10	40	60	165	M8x14(n.8)	45°	8	31.3	16.3
040/090	13	160	102	135	71.5	11	45	70	182	M10x18(n.8)	45°	10	38.3	19.9
050/110	14	200	125	167.5	84	14	50	85	225	M10x18(n.8)	45°	12	45.3	34.5

(!) **Nota:** Il peso in kg si riferisce al motoriduttore ECMM 250 /...

**Note:** The weight in kg is referred to the gearmotor ECMM 250 /...

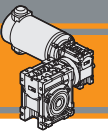

**Dimensioni**

**Dimensions**

**ECMM250/...U**

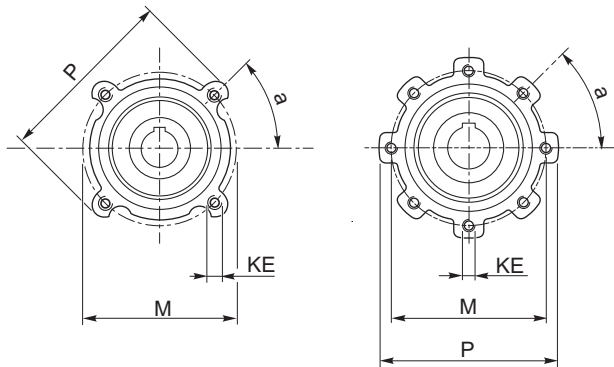
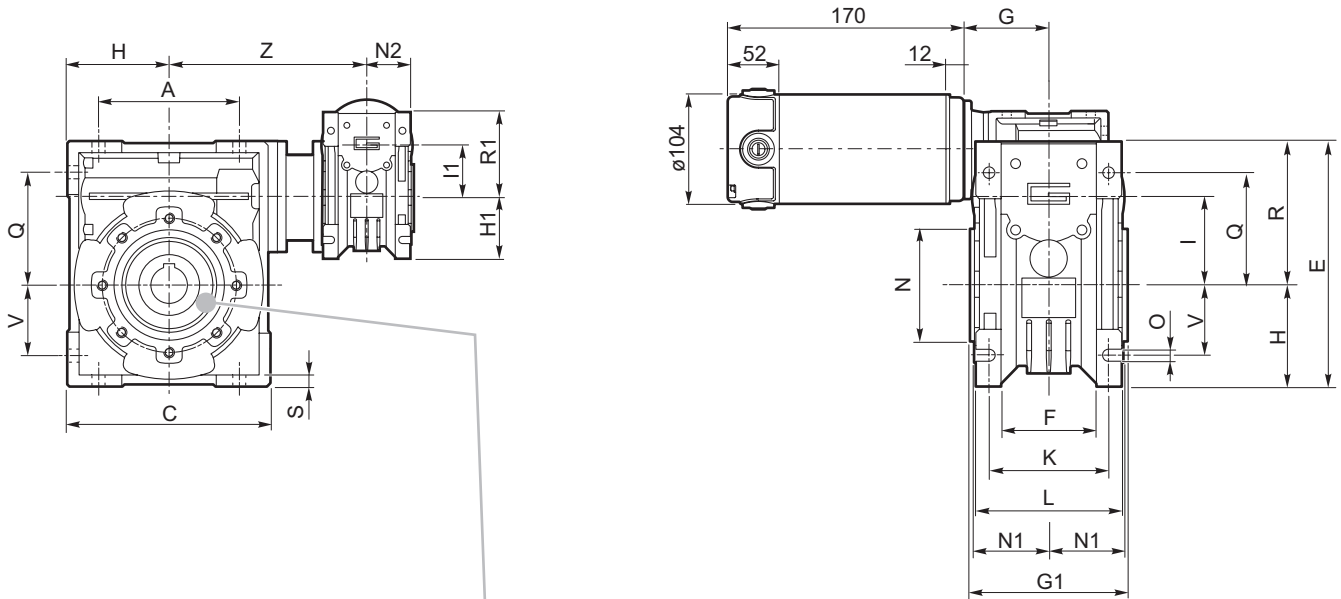

..030/040 ..030/050

..030/063 ..040/070  
..040/075 ..040/090  
..050/110

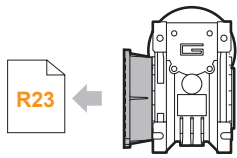

**ECMM250/... F**  
**ECMM250/... FL**  
**ECMM250/... FB**

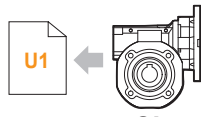

**CL**

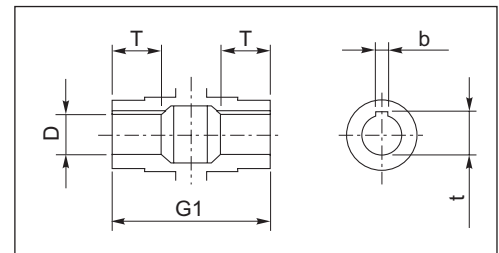

Albero lento cavo / Hollow output shaft

**Motori / Motors IP66**



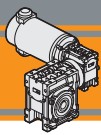

### Dimensioni

### Dimensions

CMM..U - CMM..F - CMM..FB - CMM..FL																	
	A	C	D <sub>H8</sub>	E	F	G	G1	H	H1	I	I1	K	L	M	N <sub>H8</sub>	N1	N2
030/040	70	100	18	121.5	43	55	78	50	40	40	30	60	71	75	60	36.5	29
030/050	80	120	25	144	49	55	92	60	40	50	30	70	85	85	70	43.5	29
030/063	100	144	25	174	67	55	112	72	40	63	30	85	104	95	80	53	29
040/070	110	160	28	195	64	70	120	80	50	70	40	90	104	115	95	57	35.5
040/075	120	172	28	205	72	70	120	86	50	75	40	90	112	115	95	57	36.5
040/090	140	208	35	238	74	70	140	103	50	90	40	100	130	130	110	67	36.5
050/110	170	252.5	42	295	—	80	155	127.5	60	110	50	115	144	165	130	74	43.5
063/130 <sup>(1)</sup>	200	292.5	45	335	—	95	170	147.5	72	130	63	120	155	215	180	81	53

CMM..U - CMM..F - CMM..FB - CMM..FL														
	O	P	Q	R	R1	S	T	V	Z	KE	a	b	t	Kg (!)
030/040	6.5	87	55	71.5	57	6.5	26	35	122	M6x8(n.4)	45°	6	20.8	9.2
030/050	8.5	98	64	84	57	7	30	40	132	M8x10(n.4)	45°	8	28.3	10.3
030/063	8.5	110	80	102	57	8	36	50	145	M8x10(n.8)	45°	8	28.3	12.3
040/070	9	130	91	115	71.5	9	40	55	160	M8x14(n.8)	45°	8	31.3	16.3
040/075	11	140	93	119	71.5	10	40	60	165	M8x14(n.8)	45°	8	31.3	17.3
040/090	13	160	102	135	71.5	11	45	70	182	M10x18(n.8)	45°	10	38.3	20.9
050/110	14	200	125	167.5	84	14	50	85	225	M10x18(n.8)	45°	12	45.3	35.5
063/130 <sup>(1)</sup>	16	250	140	187.5	102	15	60	100	245	M12x21(n.8)	45°	14	48.8	60.3

(!) **Nota:** Il peso in kg si riferisce al motoriduttore ECMM 350 /...

**Note:** The weight in kg is referred to the gearmotor ECMM 350 /...

(1): Solo IEC 71 B14. Versione IP66 non disponibile

IEC 71 B14 only. IP66 version not available

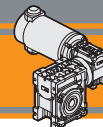

**Dimensioni**

**Dimensions**

**ECMM350/...U**

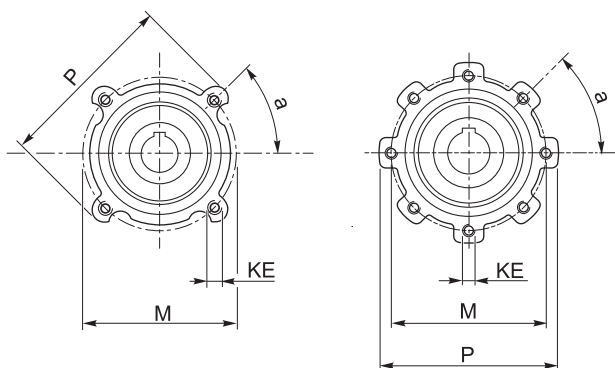
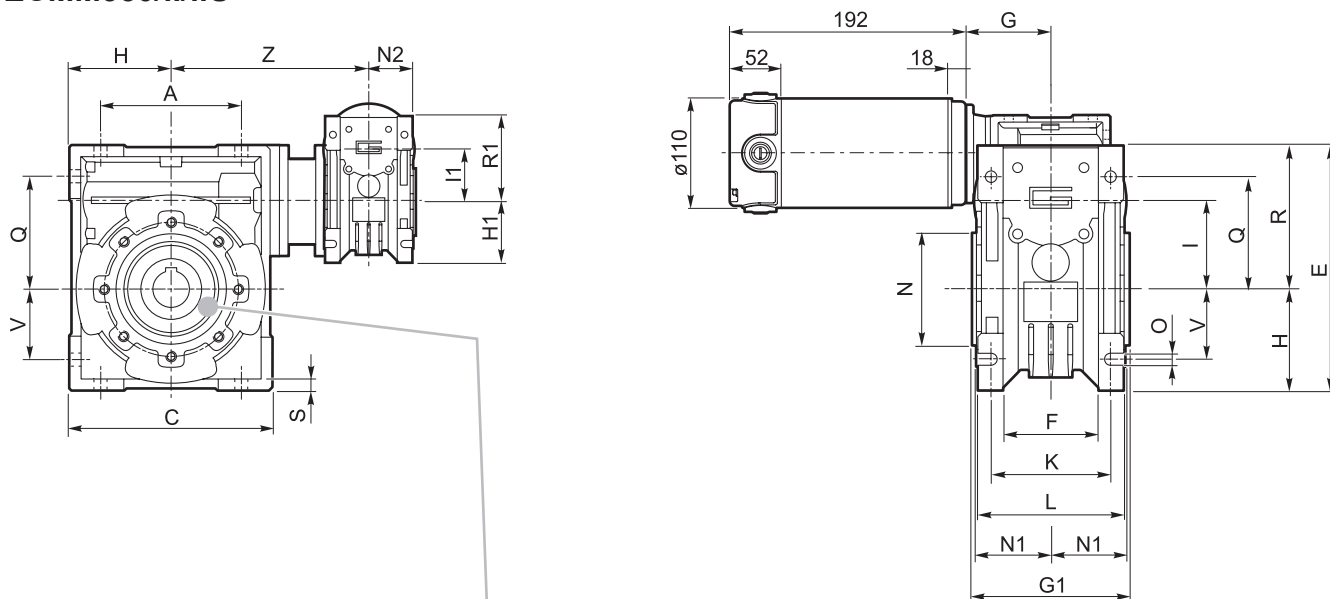

..030/040 ..030/050

..030/063 ..040/070  
..040/075 ..040/090  
..050/110 ..063/130

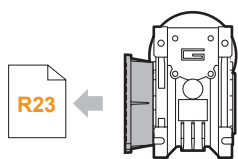

**ECMM350/... F**  
**ECMM350/... FL**  
**ECMM350/... FB**

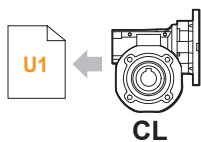

**CL**

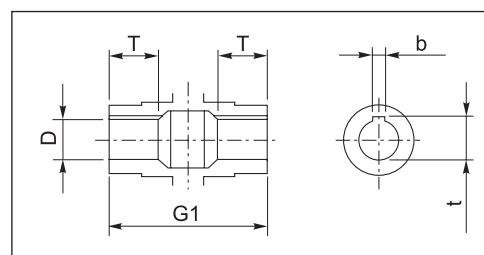

Albero lento cavo / Hollow output shaft

**Motori / Motors IP66**



- Non disponibile per  
ECMM 350/063/130  
- Not available for  
ECMM 350/063/130

**Freno / Brake**



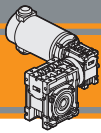

**Dimensioni**

**Dimensions**

CMM..U - CMM..F - CMM..FB - CMM..FL																	
	A	C	D <sub>H8</sub>	E	F	G	G1	H	H1	I	I1	K	L	M	N <sub>h8</sub>	N1	N2
<b>040/070</b>	110	160	28	195	64	70	120	80	50	70	40	90	104	115	95	57	35.5
<b>040/075</b>	120	172	28	205	72	70	120	86	50	75	40	90	112	115	95	57	36.5
<b>040/090</b>	140	208	35	238	74	70	140	103	50	90	40	100	130	130	110	67	36.5
<b>050/110</b>	170	252.5	42	295	—	80	155	127.5	60	110	50	115	144	165	130	74	43.5
<b>063/130</b>	200	292.5	45	335	—	95	170	147.5	72	130	63	120	155	215	180	81	53

CMM..U - CMM..F - CMM..FB - CMM..FL															
	O	P	Q	R	R1	S	T	V	Z	KE	a	b	t	Kg (!)	
<b>040/070</b>	9	130	91	115	71.5	9	40	55	160	M8x14(n.8)	45°	8	31.3	18.3	
<b>040/075</b>	11	140	93	119	71.5	10	40	60	165	M8x14(n.8)	45°	8	31.3	19.3	
<b>040/090</b>	13	160	102	135	71.5	11	45	70	182	M10x18(n.8)	45°	10	38.3	22.7	
<b>050/110</b>	14	200	125	167.5	84	14	50	85	225	M10x18(n.8)	45°	12	45.3	37.3	
<b>063/130</b>	16	250	140	187.5	102	15	60	100	245	M12x21(n.8)	45°	14	48.8	62.1	

(!) **Nota:** Il peso in kg si riferisce al motoriduttore ECMM 600 /...  
**Note:** The weight in kg is referred to the gearmotor ECMM 600 /...



**Dimensioni**

**Dimensions**

**ECMM600/...U**

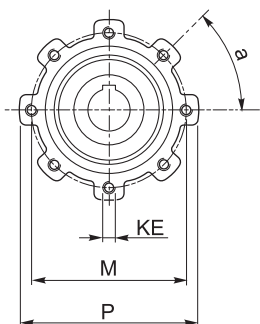
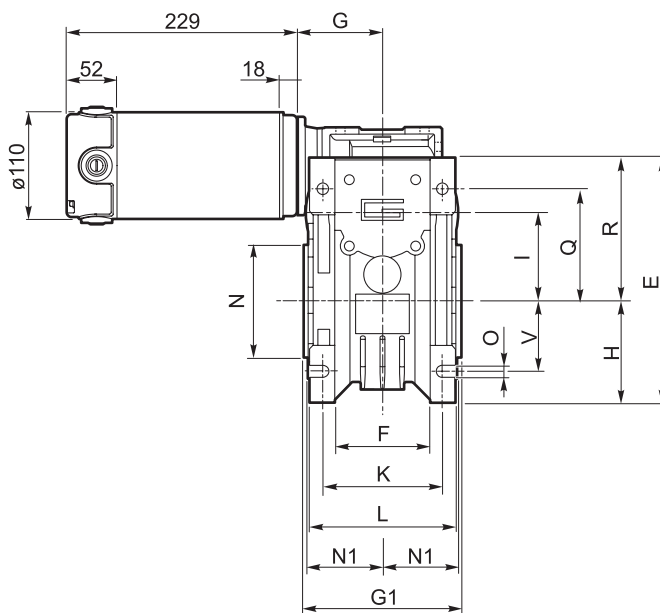
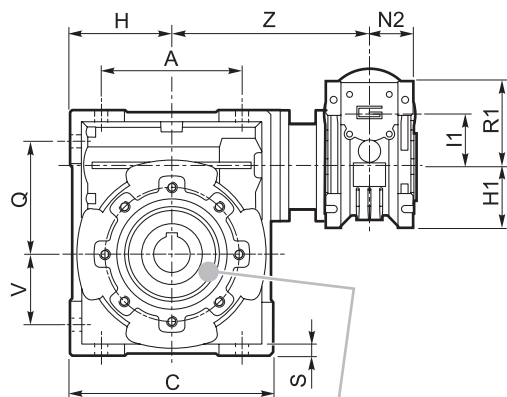

..040/070 ..040/075  
..040/090 ..050/110  
..063/130

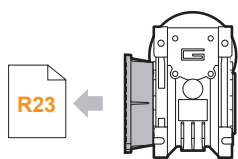

**ECMM600/... F**  
**ECMM600/... FL**  
**ECMM600/... FB**

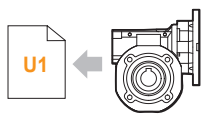

**CL**

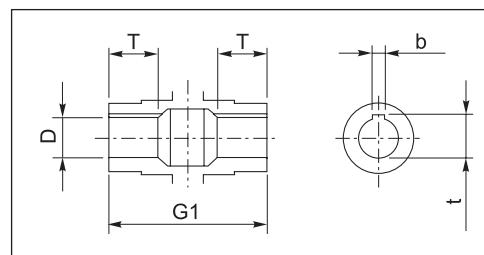

Albero lento cavo / Hollow output shaft

**Motori / Motors IP66**

**L12**

**Freno / Brake**

**I23**

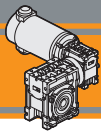
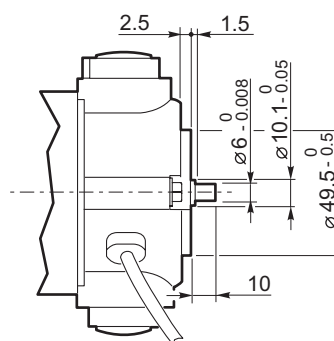
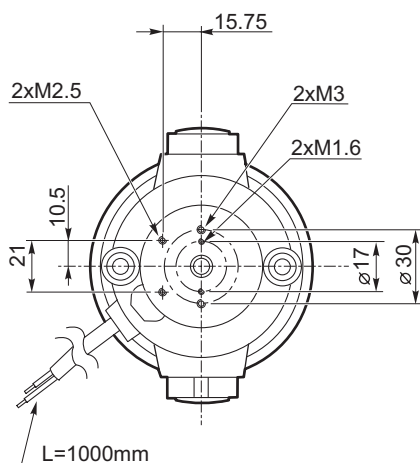
**Dimensioni****Dimensions****EC100.24E**  
**EC180.24E**

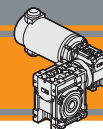

**Dimensioni**

**Dimensions**

**ECMM.../... F... Flange uscita / Output flanges**

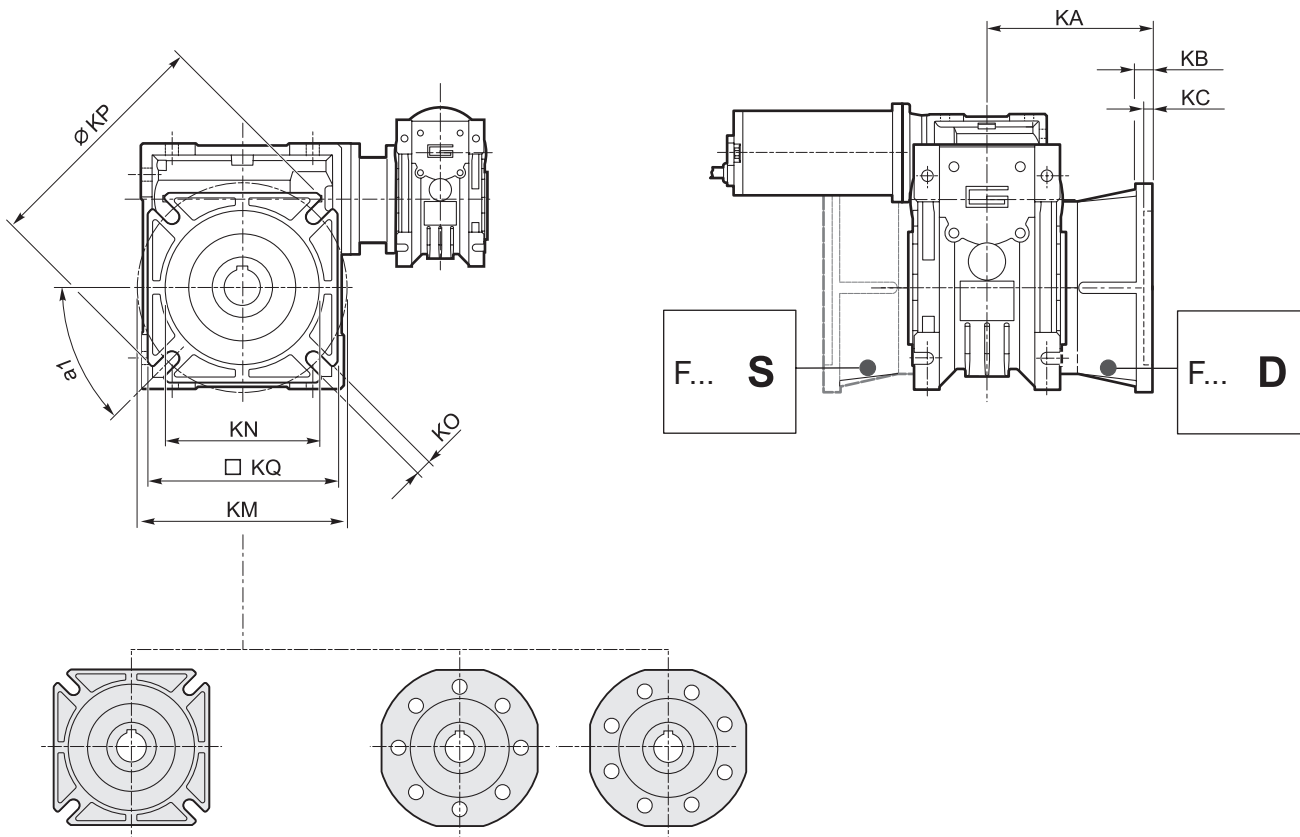

**CMM..F...**

(../026 - ../030 - ../040 - ../050  
../063 - ../070 - ../075 - ../090)

**CMM..F**

(../110) (../130)

	CMM..F								CMM..F28						CMM..F30										
	a1	KA	KB	KC	KM	KN <sub>H8</sub>	KO	KP	KQ	KA	KB	KC	KM	KN <sub>H8</sub>	KO	KP	KQ	KA	KB	KC	KM	KN <sub>H8</sub>	KO	KP	KQ
<b>026/026 (D11)</b>	45°	45	6	4.5	55-69	40	6.5(n.4)	75	70	44	6.5	5	56-64	40	6.5	70	60	48	6.5	5	68	50	6.5	80	70
<b>026/026</b>																									
<b>026/026 (D14)</b>																									

	CMM..F								CMM..FB						CMM..FL										
	a1	KA	KB	KC	KM	KN <sub>H8</sub>	KO	KP	KQ	KA	KB	KC	KM	KN <sub>H8</sub>	KO	KP	KQ	KA	KB	KC	KM	KN <sub>H8</sub>	KO	KP	KQ
<b>026/030</b>	45°	54.5	6	4	68	50	6.5(n.4)	80	70	—	—	—	—	—	—	—	—	—	—	—	—	—	—	—	—
<b>026/040</b>	45°	67	7.5	4.5	80-95	60	9(n.4)	110	95	80	8.5	5	115-125	95	9.5(n.4)	140	112	97	7.5	4.5	80-95	60	9(n.4)	110	95
<b>030/040</b>																									
<b>026/050</b>	45°	90	9	5	90-110	70	11(n.4)	125	110	89	9	5	130-145	110	9.5(n.4)	160	132	120	9	5	90-110	70	11(n.4)	125	110
<b>030/050</b>																									
<b>040/063</b>	45°	82	10	6	150-160	115	11(n.4)	180	142	98	10	5	165-180	130	11(n.4)	200	112	112	10	6	150-160	115	11(n.4)	180	142
<b>040/070</b>	45°	107	13	6	165-180	130	14(n.4)	200	170	—	—	—	—	—	—	—	—	—	—	—	—	—	—	—	—
<b>040/075</b>	45°	111	13	6	165-180	130	14(n.4)	200	170	—	—	—	—	—	—	—	—	—	—	—	—	—	—	—	—
<b>040/090</b>	45°	111	13	6	175-190	152	14(n.4)	210	200	—	—	—	—	—	—	—	—	—	—	—	—	—	—	—	—
<b>050/110</b>	45°	131	15	6	230	170	14(n.8)	280	260	—	—	—	—	—	—	—	—	—	—	—	—	—	—	—	—
<b>063/130</b>	22.5°	140	15	6	255	180	16(n.8)	320	290	—	—	—	—	—	—	—	—	—	—	—	—	—	—	—	—

**ECMM**

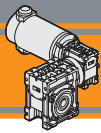

**VS1 - VS2 - Vite sporgente / Extended input shaft**

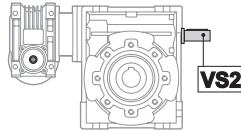
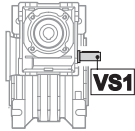
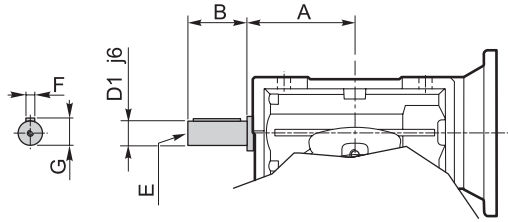

CMM	VS1						VS2					
	A	B	D <sub>1</sub> j6	E	F	G	A	B	D <sub>1</sub> j6	E	F	G
026/030	—	—	—	—	—	—	45	20	9	M4	3	10.2
026/040	—	—	—	—	—	—	53	23	11	M5	4	12.5
026/050	—	—	—	—	—	—	64	30	14	M6	5	16
030/040	45	20	9	M4	3	10.2	53	23	11	M5	4	12.5
030/050	45	20	9	M4	3	10.2	64	30	14	M6	5	16
030/063	45	20	9	M4	3	10.2	75	40	19	M6	6	21.5
040/070	53	23	11	M5	4	12.5	84	40	19	M6	6	21.5
040/075	53	23	11	M5	4	12.5	90	50	24	M8	8	27
040/090	53	23	11	M5	4	12.5	108	50	24	M8	8	27
050/110	64	30	14	M6	5	16	135	60	28	M10	8	31
063/130	75	40	19	M6	6	21.5	—	—	—	—	—	—

Costruito su richiesta  
Built on request

Accessori

Accessories

**SC - Safety cover**

**WD - Washdown cover**

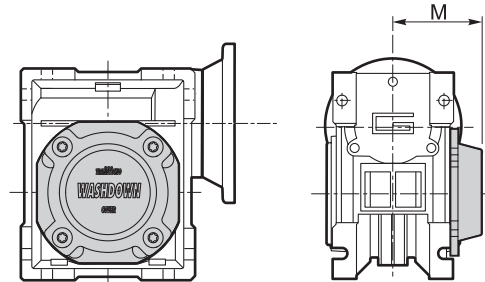
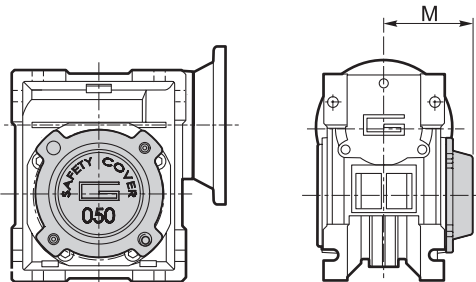

M	CM								
	30	40	50	63	70	75	90	110	130
M	47	54.5	62.5	73	79	79	94	102	117

M	CM								
	30	40	50	63	70	75	90	110	130
M	48	55.5	63.5	71.5	76	80	95	103	117

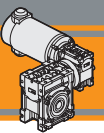

Albero lento semplice e doppio

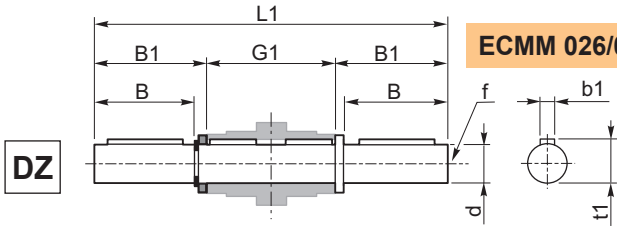

ECMM 026/030 - ECMM 063/130

Single and double output shaft

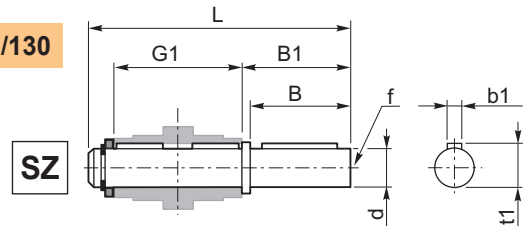

ECMM	d <sub>h7</sub>	B	B1	G1	L	L1	f	b1	t1
026/030	14	30	32.5	63	102	128	M6	5	16
026/040 030/040	18	40	43	78	128	164	M6	6	20.5
026/050 030/050	25	50	53.5	92	153	199	M10	8	28
030/063	25	50	53.5	112	173	219	M10	8	28
040/070	28	60	63.5	120	192	247	M10	8	31
040/075	28	60	63.5	120	192	247	M10	8	31
040/090	35	80	84.5	140	234	309	M12	10	38
050/110	42	80	84.5	155	249	324	M16	12	45
063/130	45	80	85	170	265	340	M16	14	48.5

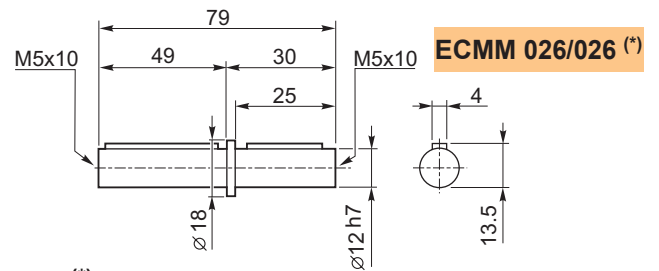

ECMM 026/026 (\*)

(\*)  
Nota: disponibile solo per cavo uscita Ø12  
Note: available for output hollow shaft Ø12 only

Braccio di reazione

ECMM	K1	G	KG	KH	R
026/030	85	14	23	8	15
026/040 030/040	100	14	31	10	18
026/050 030/050	100	14	38	10	18
030/063	150	14	47.5	10	18
040/070	200	25	46.5	20	30
040/075	200	25	46.5	20	30
040/090	200	25	56.5	20	30
050/110	250	30	62	25	35
063/130	250	30	69	25	35

Torque arm

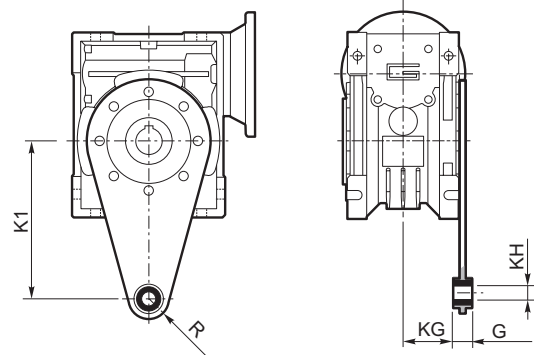





Ferrite

Motoriduttori CC  
ad ingranaggi cilindrici monostadio  
**Single stage helical gearmotors**





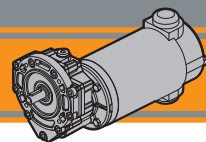

<b>Indice</b>	<b>Index</b>	Pag. Page
Caratteristiche tecniche	<i>Technical features</i>	<b>S2</b>
Designazione	<i>Classification</i>	<b>S2</b>
Sensi di rotazione	<i>Direction of rotation</i>	<b>S3</b>
Simbologia	<i>Symbols</i>	<b>S3</b>
Lubrificazione	<i>Lubrication</i>	<b>S3</b>
Carichi radiali	<i>Radial loads</i>	<b>S4</b>
Dati tecnici	<i>Technical data</i>	<b>S5</b>
Dimensioni	<i>Dimensions</i>	<b>S6</b>

Questa sezione annulla e sostituisce ogni precedente edizione o revisione. Qualora questa sezione non Vi sia giunta in distribuzione controllata, l'aggiornamento dei dati ivi contenuto non è assicurato. **In tal caso la versione più aggiornata è disponibile sul nostro sito internet [www.transtecno.com](http://www.transtecno.com)**

*This section replaces any previous edition and revision. If you obtained this catalogue other than through controlled distribution channels, the most up to date content is not guaranteed. In this case the latest version is available on our web site [www.transtecno.com](http://www.transtecno.com)*

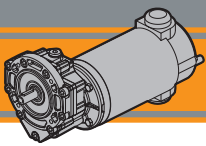

### Caratteristiche tecniche

I motoriduttori ad ingranaggi cilindrici monostadio ECPS presentano una compattezza che li rende ideali nelle applicazioni che necessitano di ingombri ridotti.

Le caratteristiche principali sono:

- Alimentazione in bassa tensione 12/24 Vcc
- Possibilità di montaggio encoder
- Potenze motore disponibili da 100 a 800W S2
- Magneti in ferrite
- Carcasse dei riduttori in pressofusione di alluminio
- Lubrificazione permanente con olio sintetico
- Ingranaggi sempre rettificati
- Disponibili con giunto elastico in entrata

### Technical features

ECPS single stage helical gearmotors introduce a unique compactness that makes them ideal for applications requiring reduced space.

The main features are:

- Low voltage power supply 12/24 Vdc
- Suitable for encoder assembly
- Motor power ratings available from 100 to 800W S2
- Ferrite magnets
- Die-cast aluminum housing
- Permanent synthetic oil long-life lubrication
- Ground helical gears
- Input flexible coupling available

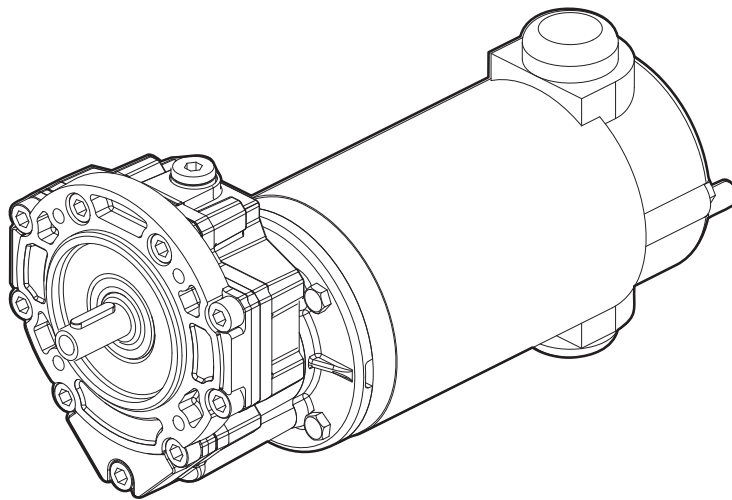

### Designazione

### Classification

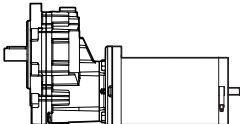
MOTORIDUTTORE / GEARMOTOR										
ECPS	070/56					F63B14	3	D11	240	
Tipo Type	Grandezza Size					Versione Riduttore Gearbox Version	Rapporto Ratio	Albero di uscita Output shaft	Versione Motore Motor Version	
 ECPS	070/56	100/56	180/56	250/63	350/63	600/71	F63B14	3	D11	120
			180/63	250/71	350/71		F71B14			
							F80B14	8	D19	240
							F90B14		D24	

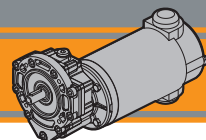

**Sensi di rotazione**

**Direction of rotation**

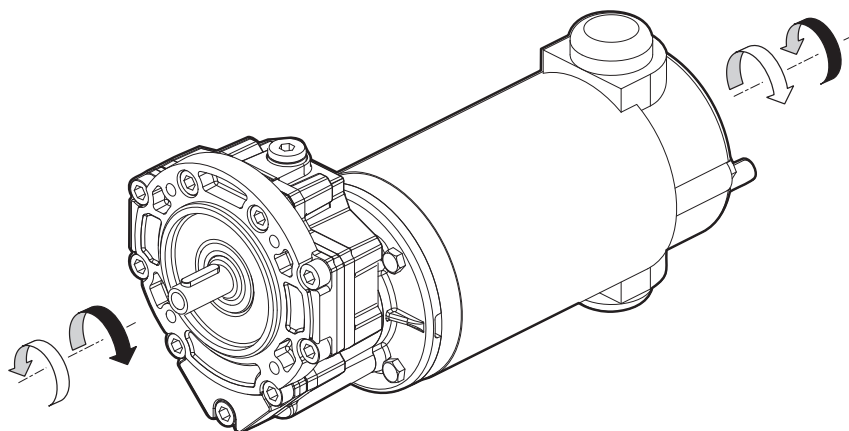

**Simbologia**

**Symbols**

$n_1$	[min <sup>-1</sup> ]	Velocità in ingresso / <i>Input speed</i>
$n_2$	[min <sup>-1</sup> ]	Velocità in uscita / <i>Output speed</i>
$i$		Rapporto di riduzione / <i>Ratio</i>
$P_1$	[kW]	Potenza in entrata / <i>Input power</i>
$M_2$	[Nm]	Coppia nominale in uscita in funzione di $P_1$ / <i>Output torque referred to <math>P_1</math></i>
$P_{n1}$	[kW]	Potenza nominale in entrata / <i>Nominal input power</i>
$M_{n2}$	[Nm]	Coppia nominale in uscita in funzione di $P_{n1}$ / <i>Nominal output torque referred to <math>P_{n1}</math></i>
$sf$		Fattore di servizio / <i>Service factor</i>
$R_2$	[N]	Carico radiale ammissibile in uscita / <i>Permitted output radial load</i>
$A_2$	[N]	Carico assiale ammissibile in uscita / <i>Permitted output axial load</i>

**Lubrificazione**

**Lubrication**

Tutti i motoriduttori sono forniti completi di lubrificante sintetico viscosità 320, pertanto possono essere installati in qualunque posizione di montaggio e non necessitano di manutenzione.

*Permanent synthetic oil long-life lubrication ( viscosity grade 320) makes it possible to use the gearmotors in all mounting positions; for this reason they can be installed in any assembly position and do not require maintenance.*

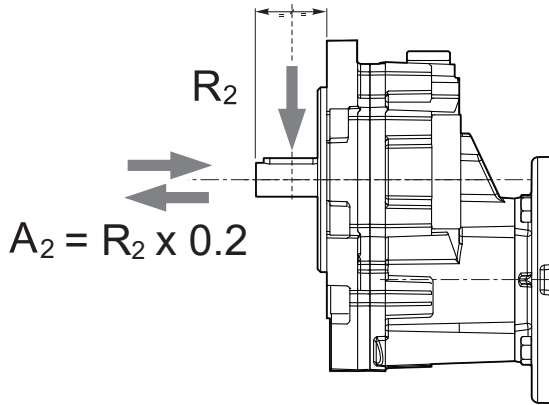
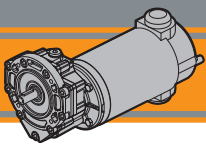

$n_2$ [min <sup>-1</sup> ]	$R_2$ [N]		
	PS56	PS63	PS71
1000	300	300	600
600	350	350	700
470	400	400	800
375	500	500	1000
280	500	500	1000
175	500	500	1000

Quando il carico radiale risultante non è applicato sulla mezza-  
ria dell'albero occorre calcolare quello effettivo con la seguente  
formula:

When the resulting radial load is not applied on the centre line  
of the shaft it is necessary to calculate the effective load with the  
following formula:

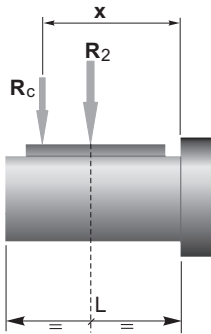

	PS56 / PS63	PS56 / PS63	PS71	PS71
	F63B14	F71B14	F80B14	F90B14
<b>a</b>	47	50.5	70	75
<b>b</b>	35.5	35.5	50	50
<b>R<sub>2MAX</sub></b>	500	500	1000	1000

$$R_c = \frac{R_2 \cdot a}{(b + x)} \leq R_{2MAX}$$

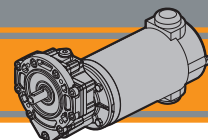

$$R \leq R_c$$

*a, b = valori riportati nella tabella*  
*a, b = values given in the table*

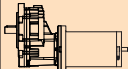
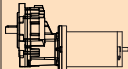

Dati tecnici

Technical data

$P_1$ [W]	$n_2$ [min <sup>-1</sup> ]	$M_2$ [Nm]	sf	i		Versione motore Motor version	$P_1$ [W]	$n_2$ [min <sup>-1</sup> ]	$M_2$ [Nm]	sf	i		Versione motore Motor version
<b>100</b>							<b>500</b>						
(3000 min <sup>-1</sup> )	<b>1000</b>	0.9	11.8	3	<b>070/56</b>	120/240	(3000 min <sup>-1</sup> )	<b>1000</b>	4.7	2.4	3	<b>350/63</b>	120/240
	<b>600</b>	1.6	7.7	5		120.66/240.66		<b>600</b>	7.8	1.5	5		120.66/240.66
	<b>375</b>	2.5	4.8	8				<b>375</b>	12.5	1.0	8		
<b>140</b>							<b>500</b>						
(3000 min <sup>-1</sup> )	<b>1000</b>	1.3	8.4	3	<b>100/56</b>	120/240/24E		<b>1000</b>	4.7	6.6	3	<b>350/71</b>	120/240
	<b>600</b>	2.2	5.5	5		120.66/240.66		<b>600</b>	7.8	4.5	5		IEC 71
	<b>375</b>	3.5	3.4	8				<b>375</b>	12.5	3.1	8		 Solo / Only
<b>250</b>							<b>800</b>						
(3000 min <sup>-1</sup> )	<b>1000</b>	2.3	4.7	3	<b>180/56</b>	120/240	(3000 min <sup>-1</sup> )	<b>1000</b>	7.5	4.1	3	<b>600/71</b>	120/240
	<b>600</b>	3.9	3.1	5		120.66/240.66		<b>600</b>	12.5	2.8	5		120.66/240.66
	<b>375</b>	6.2	1.9	8				<b>375</b>	20.0	2.0	8		
	<b>1000</b>	2.3	4.7	3	<b>180/63</b>	24E							
	<b>600</b>	3.9	3.1	5									
	<b>375</b>	6.2	1.9	8									
<b>350</b>													
(3000 min <sup>-1</sup> )	<b>1000</b>	3.3	3.4	3	<b>250/63</b>	120/240							
	<b>600</b>	5.5	2.2	5		120.66/240.66							
	<b>375</b>	8.7	1.4	8									
	<b>1000</b>	3.3	9.5	3	<b>250/71</b>	120/240							
	<b>600</b>	5.5	6.4	5		IEC 71B14							
	<b>375</b>	8.7	4.5	8		 Solo / Only							

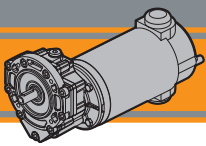

**ECPS**

Motoriduttori CC ad ingranaggi cilindrici monostadio  
DC Single stage helical gearmotors

Dimensioni

Dimensions

**ECPS 070/56**

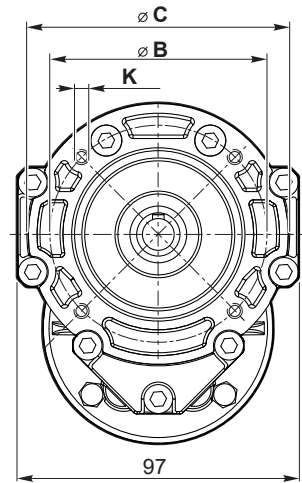
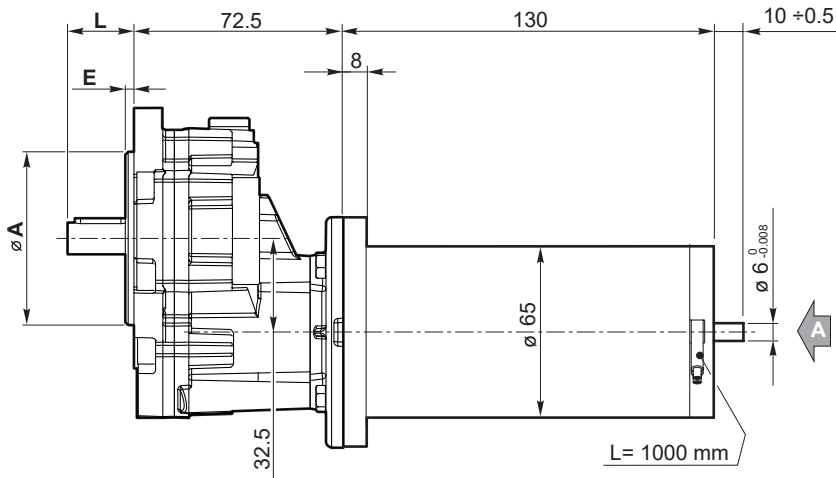

Albero uscita  
Output shaft

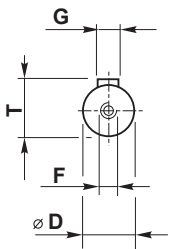

Vista da A  
View from A

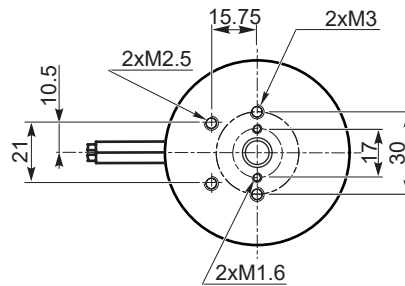

Freno / Brake



Encoder



Motori / Motors IP66



Flangia uscita Output flange	A	B	C	E	K
F63B14	60	75	90	3	M5
F71B14	70	85	105	3	M6

Albero uscita Output shaft	D	L	F	G	T
D11	11	23	M4	4	12.5
D14	14	30	M5	5	16

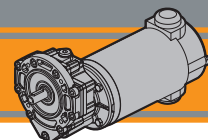

Dimensioni

Dimensions

ECPS 100/56

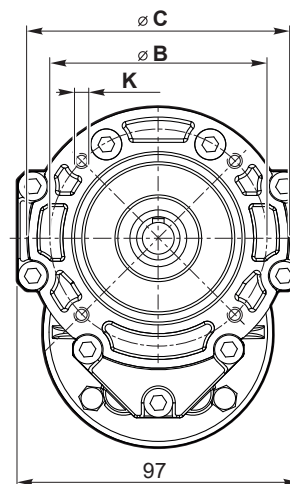
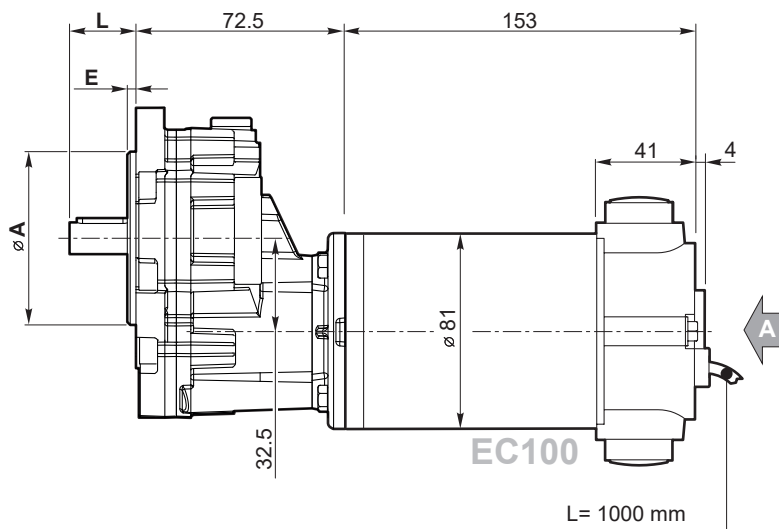

Albero uscita  
Output shaft

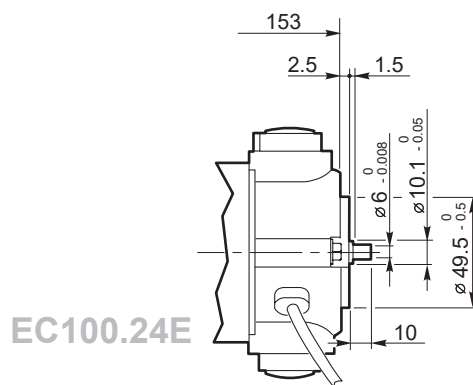
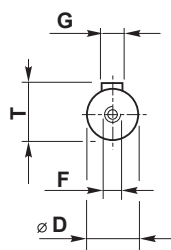

- Freno / Brake → I23
- Encoder → I24
- Motori / Motors IP66 → L4

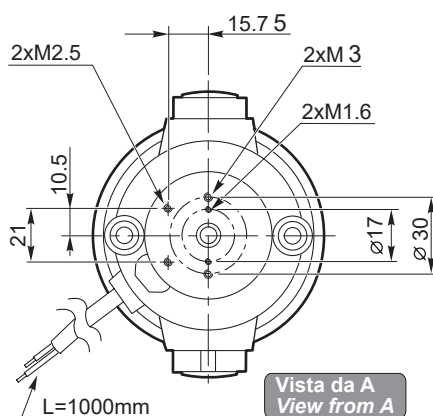

Flangia uscita Output flange	A	B	C	E	K
F63B14	60	75	90	3	M5
F71B14	70	85	105	3	M6

Albero uscita Output shaft	D	L	F	G	T
D11	11	23	M4	4	12.5
D14	14	30	M5	5	16

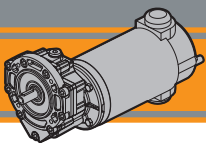

**Dimensioni**

**Dimensions**

**ECPS 180/56**

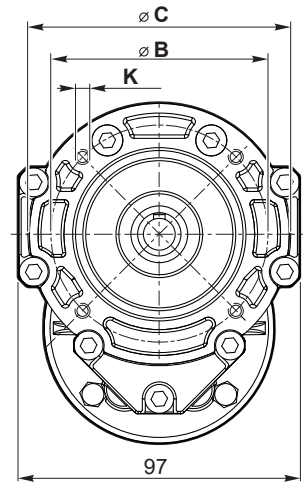
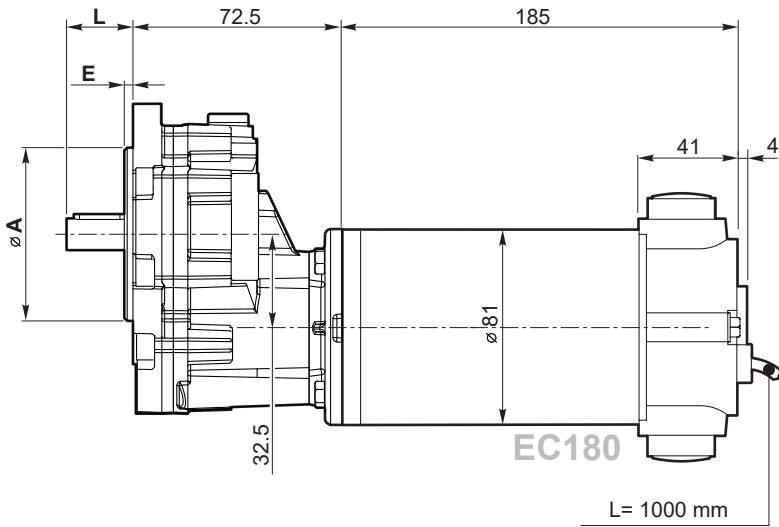

Albero uscita  
 Output shaft

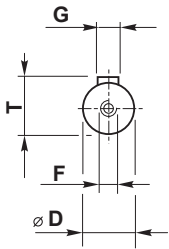

Motors / Motors IP66



Flangia uscita Output flange	A	B	C	E	K
F63B14	60	75	90	3	M5
F71B14	70	85	105	3	M6

Albero uscita Output shaft	D	L	F	G	T
D11	11	23	M4	4	12.5
D14	14	30	M5	5	16

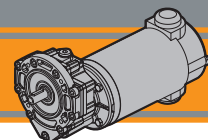

Dimensioni

Dimensions

ECPS 180/63

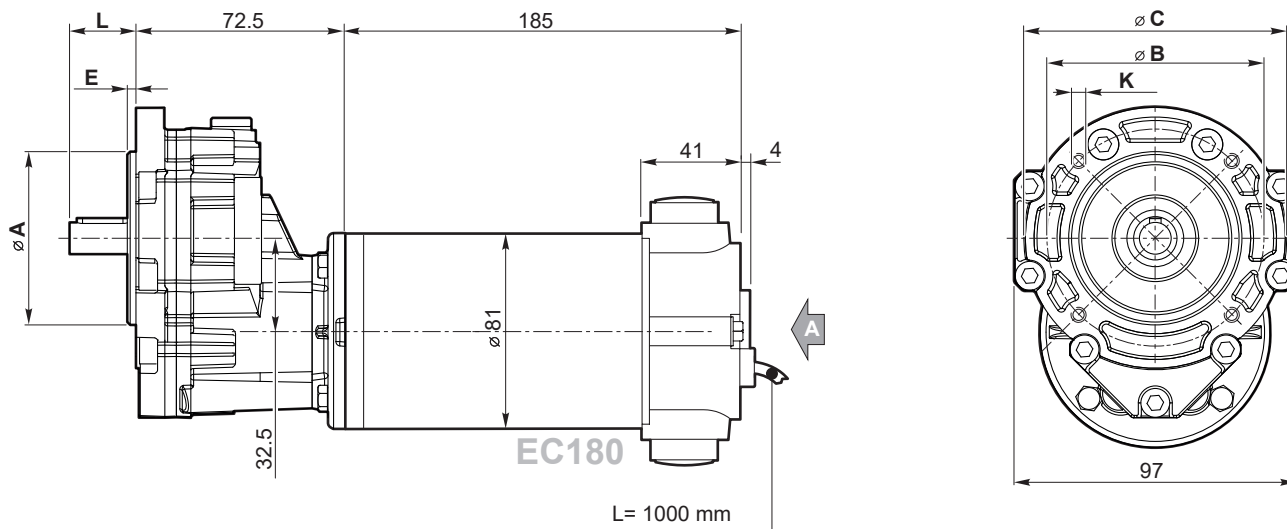

Albero uscita  
Output shaft

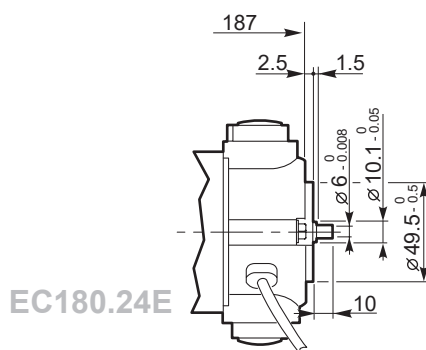
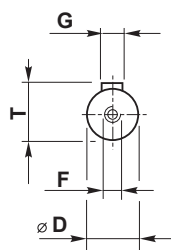

- Freno / Brake → I23
- Encoder → I24

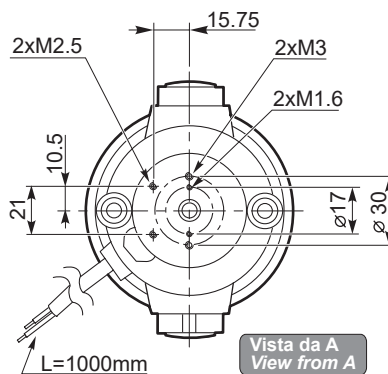

Flangia uscita Output flange	A	B	C	E	K
F63B14	60	75	90	3	M5
F71B14	70	85	105	3	M6

Albero uscita Output shaft	D	L	F	G	T
D11	11	23	M4	4	12.5
D14	14	30	M5	5	16

ECPS

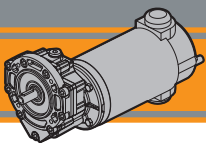

**Dimensioni**

**Dimensions**

**ECPS 250/63**

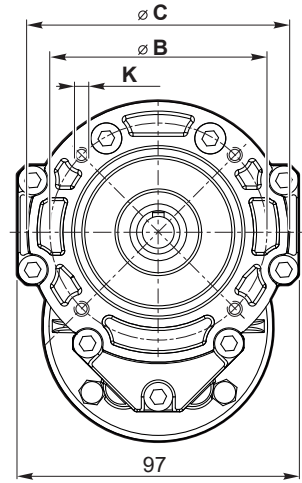
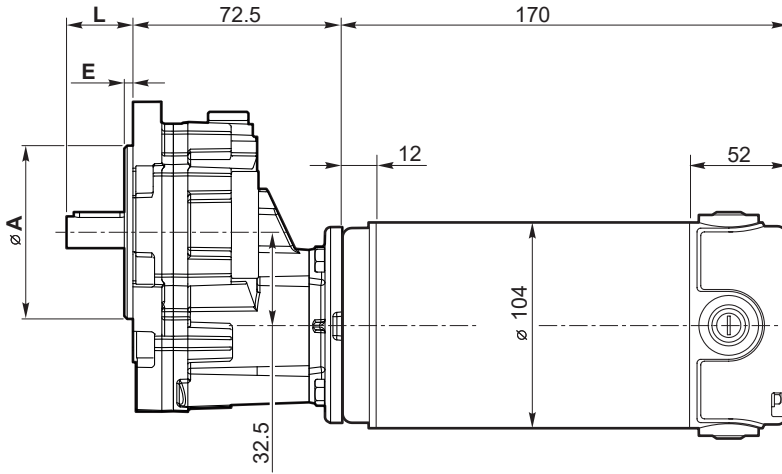

Albero uscita  
Output shaft

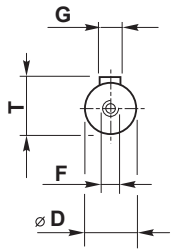

Motori / Motors IP66



Flangia uscita Output flange	A	B	C	E	K
F63B14	60	75	90	3	M5
F71B14	70	85	105	3	M6

Albero uscita Output shaft	D	L	F	G	T
D11	11	23	M4	4	12.5
D14	14	30	M5	5	16

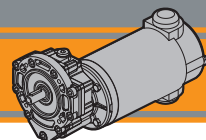

Dimensioni

Dimensions

ECPS 250/71

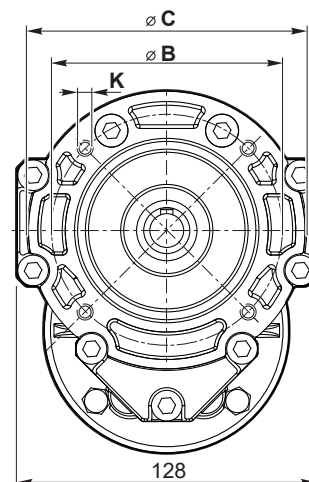
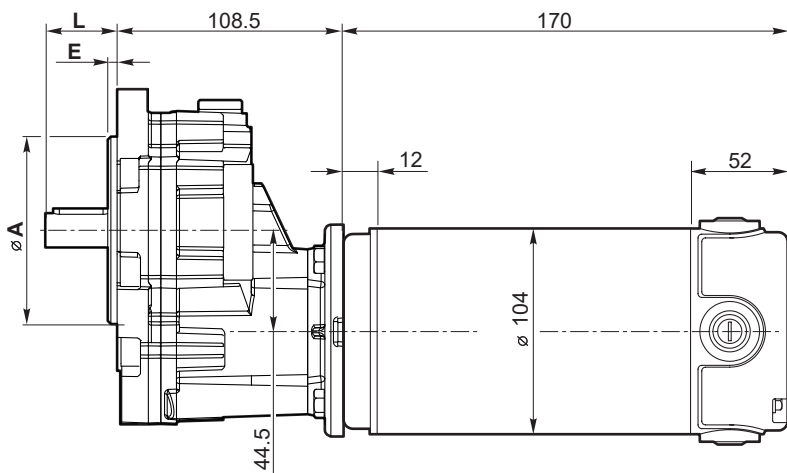

Albero uscita  
Output shaft

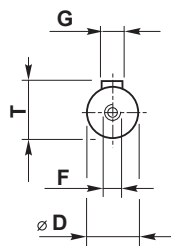

Flangia uscita Output flange	A	B	C	E	K
F80B14	80	100	120	3	M6
F90B14	95	115	140	3	M8

Albero uscita Output shaft	D	L	F	G	T
D19	19	40	M6	6	21.5
D24	24	50	M8	8	27

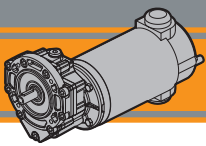

**Dimensioni**

**Dimensions**

**ECPS 350/63**

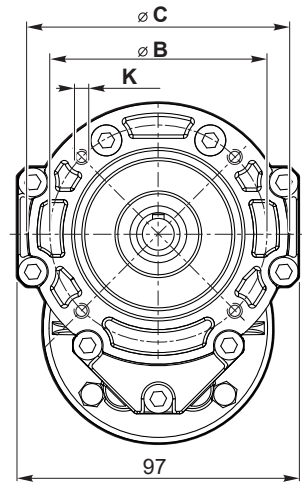
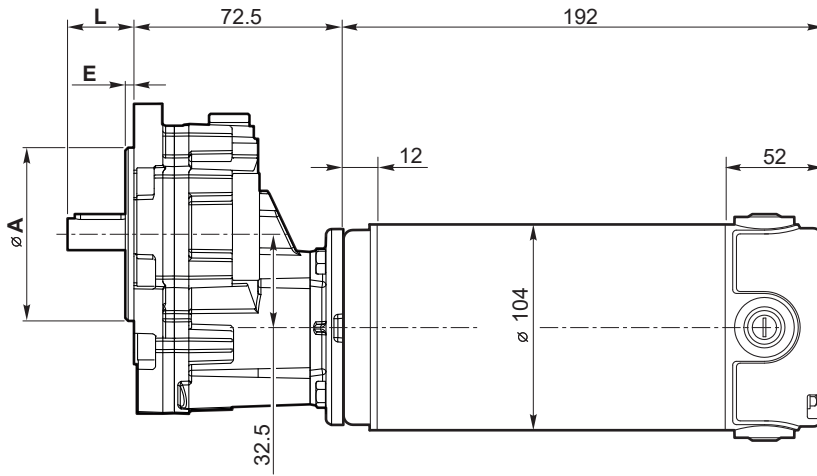

Albero uscita  
Output shaft

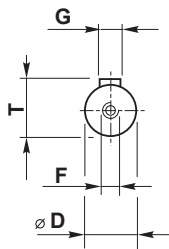

Freno / Brake



Motori / Motors IP66



Flangia uscita Output flange	A	B	C	E	K
F63B14	60	75	90	3	M5
F71B14	70	85	105	3	M6

Albero uscita Output shaft	D	L	F	G	T
D11	11	23	M4	4	12.5
D14	14	30	M5	5	16

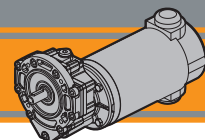

Dimensioni

Dimensions

ECPS 350/71

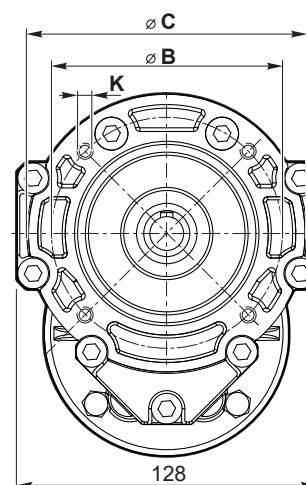
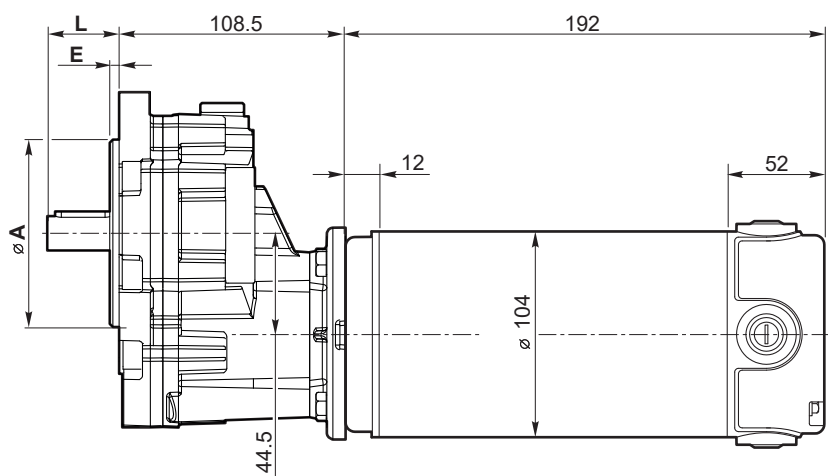

Albero uscita  
Output shaft

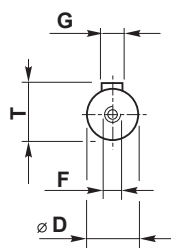

Flangia uscita Output flange	A	B	C	E	K
F80B14	80	100	120	3	M6
F90B14	95	115	140	3	M8

Albero uscita Output shaft	D	L	F	G	T
D19	19	40	M6	6	21.5
D24	24	50	M8	8	27

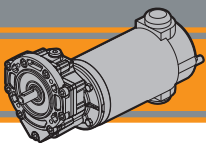

**Dimensioni**

**Dimensions**

**ECPS 600/71**

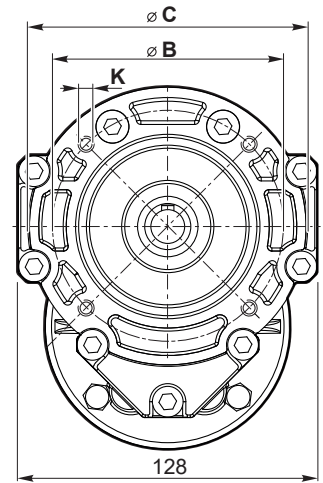
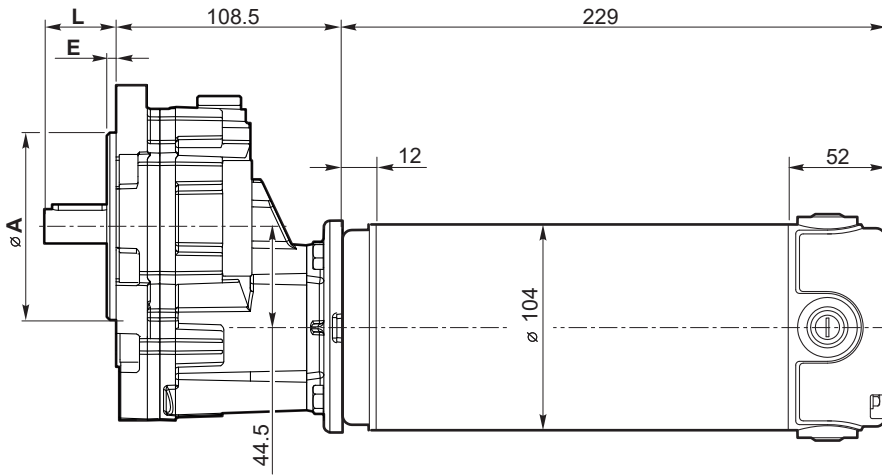

Albero uscita  
Output shaft

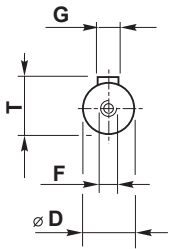

Freno / Brake → I23

Motori / Motors IP66 → L10

Flangia uscita Output flange	A	B	C	E	K
F80B14	80	100	120	3	M6
F90B14	95	115	140	3	M8

Albero uscita Output shaft	D	L	F	G	T
D19	19	40	M6	6	21.5
D24	24	50	M8	8	27



## Azionamenti per motori CC DC motor controls





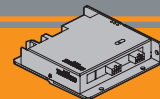

	Indice	Index	Pag. Page
<b>PLN19-8</b>	Schema dei collegamenti	<i>Main connection diagram</i>	<b>T2</b>
	Caratteristiche tecniche	<i>Technical features</i>	<b>T2</b>
	Dimensioni	<i>Dimensions</i>	<b>T3</b>
	Opzioni	<i>Options</i>	<b>T3</b>
<b>PLN20 PLN40</b>	Schema dei collegamenti	<i>Main connection diagram</i>	<b>T4</b>
	Caratteristiche tecniche	<i>Technical features</i>	<b>T5</b>
	Dotazioni	<i>Equipment</i>	<b>T5</b>
	Manuale	<i>User manual</i>	<b>T5</b>
	Dimensioni	<i>Dimensions</i>	<b>T6</b>
	GUIDA alla selezione dell'azionamento	<i>Drive selection GUIDE</i>	<b>T7</b>
	Note	<i>Note</i>	<b>T8</b>

Questa sezione annulla e sostituisce ogni precedente edizione o revisione. Qualora questa sezione non Vi sia giunta in distribuzione controllata, l'aggiornamento dei dati ivi contenuto non è assicurato. **In tal caso la versione più aggiornata è disponibile sul nostro sito internet [www.transtecno.com](http://www.transtecno.com)**

*This section replaces any previous edition and revision. If you obtained this catalogue other than through controlled distribution channels, the most up to date content is not guaranteed. In this case the latest version is available on our web site [www.transtecno.com](http://www.transtecno.com)*

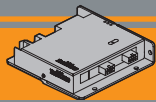

**AZIONAMENTO UNIDIREZIONALE PWM PER LA  
REGOLAZIONE DI VELOCITA' DEI MOTORI A  
CORRENTE CONTINUA A BASSA TENSIONE**

**LOW VOLTAGE SINGLE DIRECTION  
PWM DC MOTORS CONTROL**

### SCHEMA DEI COLLEGAMENTI - MAIN CONNECTION DIAGRAM

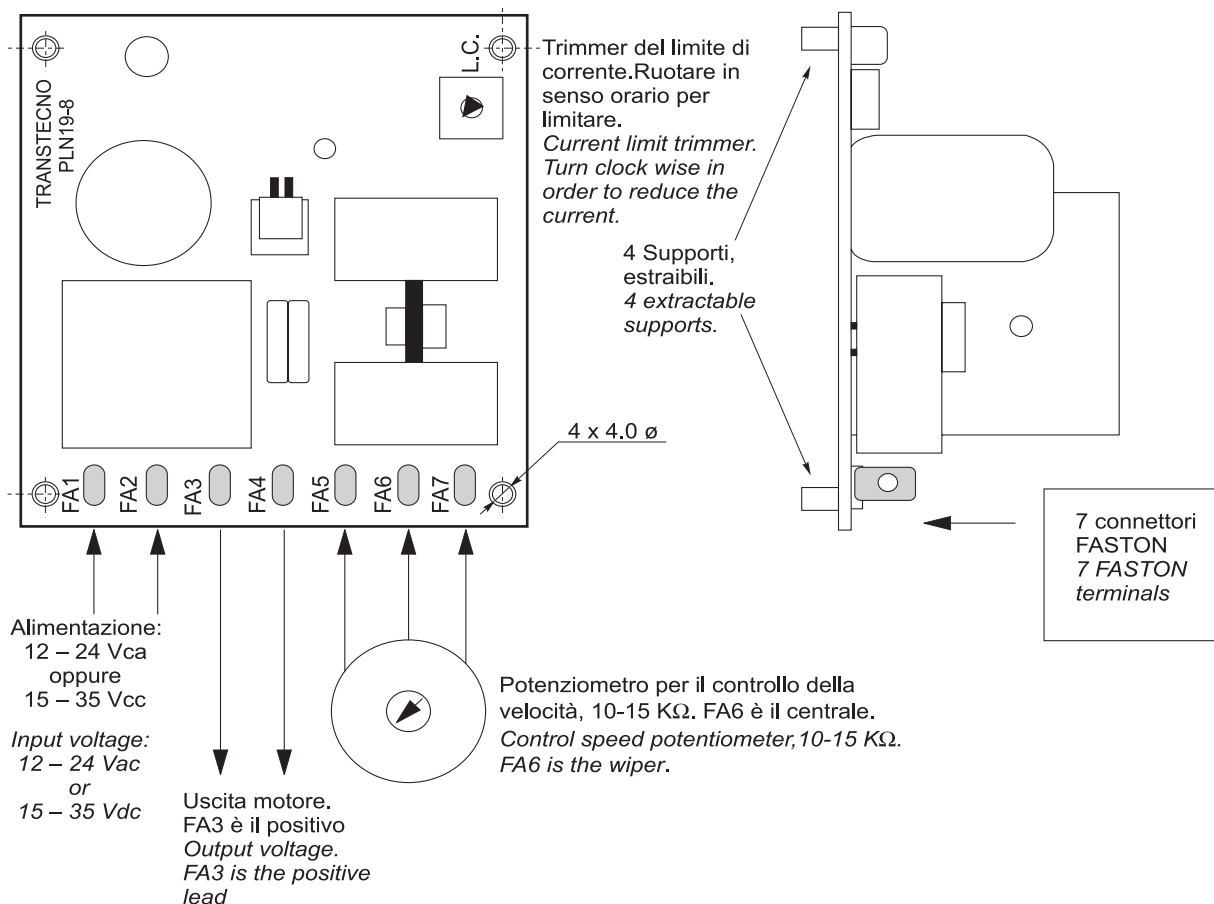

**Attenzione:** se si scollega il potenziometro con la scheda alimentata, il motore ruota alla velocità nominale.

**Warning:** if speed pot is disconnected when the board is powered, the motor runs at its maximum speed.

### Caratteristiche tecniche

### Technical features

- Alimentazione ai terminali FA1 e FA2:  
12 - 24 Vca oppure 15 - 35 Vcc.
- Regolazione della velocità mediante potenziometro 10-15 KΩ.
- Trimmer di Limitazione della corrente, per adattare la scheda anche a motori di piccole potenze. Per limitare l'erogazione di corrente, ruotare in senso orario il trimmer.
- Uscita motore ai terminali FA3 e FA4, regolabile da 0 a Vcc MAX che è proporzionale alla tensione di ingresso. Con 35 Vcc di alimentazione, l'uscita MAX è circa 30 Vcc.
- Corrente di uscita (\*): Massima corrente ammessa: 8 A in ambiente ventilato, servizio continuo.
- Peso: 0.120 Kg.
- Line voltage at terminals FA1 and FA2:  
12 - 24 Vac or 15 - 35 Vdc.
- The speed of the drive is to be controlled by potentiometer, 10-15 KΩ.
- Current Limit trimmer, in order to suit the board for small motors. In order to limit the current, turn clock wise the trimmer.
- Output voltage from terminals FA3 and FA4, from 0 up to Vdc MAX which is proportional to the input voltage. With 35 Vdc input voltage, the max output voltage is about 30 Vdc.
- Output current (\*): Maximum output current allowed: 8 A in a ventilated environment, continuous duty.
- Weight: 0.120 Kg.

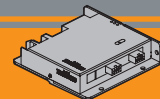

Dimensioni

Dimensions

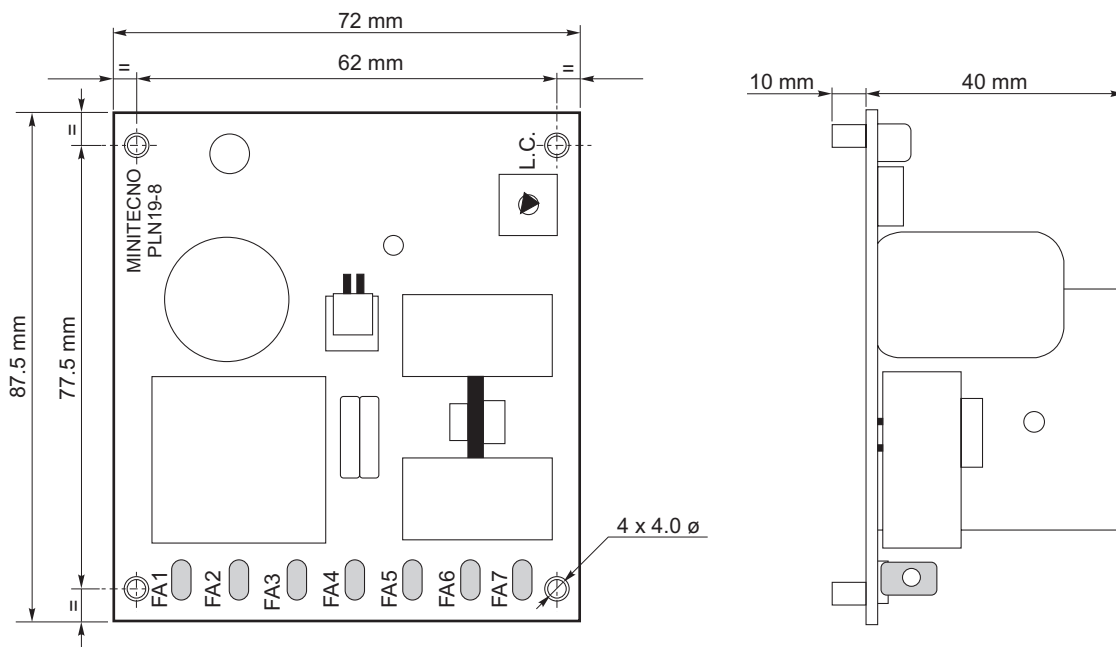

Opzioni

Options

1. Potenzimetro 10 kΩ
2. Supporto per montaggio su guida DIN

1. Speed potentiometer 10 kΩ
2. DIN mounting support

(\*) il valore massimo di corrente motore deve essere utilizzato in **ambiente ventilato**. In ambienti non ventilati e per temperatura ambiente di 45 °C, ridurre la corrente motore massima a 4 A; servizio continuo.

(\*) *the maximum output current value must be used in a ventilated environment. Derate the maximum output current down to 4 A if the environment is not ventilated and the temperature is about 45 °C; continuous duty.*

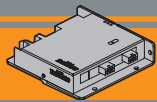

**AZIONAMENTO BIDIREZIONALE PWM PER LA  
REGOLAZIONE DI VELOCITA' DEI MOTORI A  
CORRENTE CONTINUA A BASSA TENSIONE**

**LOW VOLTAGE BIDIRECTIONAL  
PWM DC MOTORS CONTROL**

### SCHEMA DEI COLLEGAMENTI - MAIN CONNECTION DIAGRAM

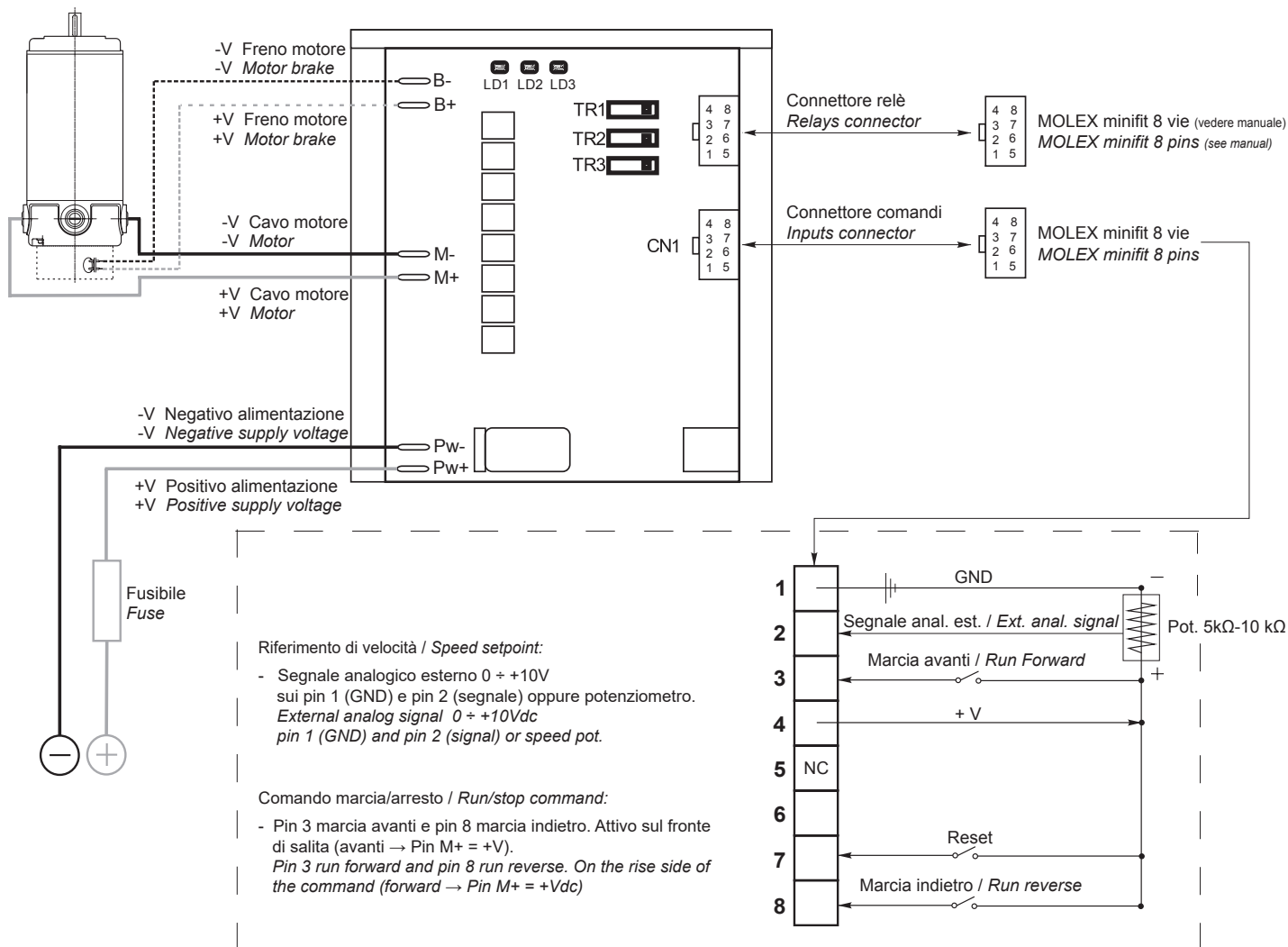

#### Fusibile:

150-200% della corrente motore. Max 3 volte la corrente nominale della scheda, con intervento entro pochi secondi.

#### Fuse:

150-200 % rated motor current. Max 3 times rated current of the drive (trip time in few seconds).

#### Trimmer multigiro:

TR1: Accelerazione: selezione da 0.5 a 10 sec.

TR2: Limite di corrente: riduce il limite di corrente nominale da 100% a circa 30% (corrente di picco 3 volte la corrente selezionata).

TR3: Decelerazione: selezione da 0.5 a 10 sec.

#### Multiturn trimmers:

TR1: Acceleration time: from 0.5 to 10 sec.

TR2: Current limitation: rated current limited from 100% to about 30% (peak current 3 times the selected limited current).

TR3: Deceleration time: from 0.5 to 10 sec.

#### LED:

LD1: Visualizza lo stato di funzionamento con limite di corrente attivo (il motore assorbe più della corrente selezionata e l'azionamento opera in limitazione).

LD2: Stato dell'azionamento: lampeggio veloce e continuo = funzionamento normale, lampeggio lento e codificato = presenza di un allarme

LD3: Segnalazione presenza alimentazione.

#### LED:

LD1: ON when the drive runs under current limitation (motor requires more than the rated current and drive supplies only limited current).

LD2: Status: quick continuous flash = drive ok, slow coded flash = fault).

LD3: Power ON

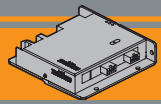

## Caratteristiche tecniche

## Technical features

- Scheda bidirezionale a transistor a ricircolo di corrente.
  - Selezionabili i seguenti parametri (mediante trimmer):
    - rampa di accelerazione: 0.5 - 10 sec
    - rampa di decelerazione: 0.5 - 10 sec
    - limite corrente 100%-30% circa
  - Temperatura di lavoro: 0°C / +40°C (allarme sotto zero)
  - Diagnostica tramite LED
  - Frequenza di commutazione: 16kHz
  - Dotata di coperchio
  - Velocità regolabile con potenziometro 5-10 kΩ o con segnale 0-10 Vcc
  - Limitazione della corrente regolabile
  - Sensore termico di protezione
- *Transistor bidirectional drive with regenerative current system.*
  - *Following settings can be adjusted (by built in trimmers):*
    - *acceleration ramp: 0.5 - 10 sec*
    - *deceleration ramp: 0.5 - 10 sec*
    - *current limit 100% - about 30%*
  - *Room temperature: 0°C / +40°C (alarm below zero)*
  - *LED for system diagnosis*
  - *Switching frequency: 16kHz*
  - *Covered*
  - *5-10 kΩ Speed pot. or 0-10 Vdc external signal for speed re-  
gulation*
  - *Variable current limit*
  - *Thermal sensor for protection*

Modello Model number	Tensione di alimentazione DC input voltage [Vdc]	Tensione di uscita Motor voltage [Vdc]*	Corrente di uscita nominale DC load current [A]	Corrente di picco motore Maximum load current [A]**	Campo di alimentazione Power supply range [Vdc]
<b>PLN20</b>	12 ÷ 24	0 ÷ Vin	20	60 (4 sec)	10 ÷ 30
<b>PLN40</b>	12 ÷ 24	0 ÷ Vin	40	120 (1 sec)	10 ÷ 30

\* L'azionamento riduce la tensione nominale di 1-2 Vcc. Il fenomeno è normale e fisiologico. Se serve ottenere 24 ÷ 12 Vcc in uscita sotto ogni condizione di carico, si suggerisce di sovralimentare di un paio di volt.

\*\* Un timer impone il limite con un andamento temporale iperbolico, cioè quanta più corrente eroga e tanto meno è il tempo per il quale ciò è ammesso, prima che appunto la scheda vada in limitazione. Alla corrente di picco (x 3 volte quella nominale) la scheda funziona per pochi secondi.

\* *The drive reduces the rated voltage of 1-2 Vdc. This is normal and physiological. If 24 ÷ 12 VDC output is required under all load conditions, it is advisable to supercharge a couple of volts.*

\*\* *A timer imposes a limit with a temporary hyperbolic performance, which means the more current is requested, the less time is permitted with this current before the drive is limited. When the current reaches its peak (3 times the rated value) the drive will work for a few seconds.*

## Dotazioni

## Equipment

	PLN20 PLN40
Trimmer di selezione ACCEL, DECEL e LIMITE di CORRENTE / <i>Selection Trimmer ACCEL, DECEL, CURRENT LIMIT</i>	■
2 contatti: marcia avanti e marcia indietro / <i>2 contacts : forward and reverse</i>	■
Riferimento di velocità / <i>Speed setpoint reference</i>	■
3 LEDs di segnalazione / <i>3 LEDs signals</i>	■
Segnale di comando di eventuale freno negativo di stazionamento / <i>Command signal for possible negative electromagnetic brake</i>	■
Predisposizione per montaggio a libro e a zoccolo / <i>Arranged for 2 different ways of mounting</i>	■
Memorizzazione e segnalazione degli allarmi / <i>Memory storage and report of alarm</i>	■
2 ingressi digitali ausiliari / <i>2 auxiliary digital inputs</i>	■#
1 relè segnalazione allarmi / <i>Alarm output relays</i>	■

# uno impegnato dal reset / *one comitted by reset*



**Manuale**



**User manual**

Per approfondimenti si raccomanda di scaricare il manuale d'uso dal nostro sito [www.transtecno.com](http://www.transtecno.com) alla pagina dei prodotti.

Please, download the user manual for more information from our web site [www.transtecno.com](http://www.transtecno.com) from the product page.



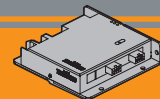

### GUIDA alla selezione dell'azionamento

### Drive selection GUIDE

Corrente di uso del motore  $\leq$  Corrente nominale dell'azionamento

Real motor current  $\leq$  Rated current of the drive

Attenzione: la reale corrente assorbita dal motore può essere diversa da quella indicata in targhetta.

PLN19-8 = max 6 A

PLN20 = max 22 A

PLN40 = max 44 A

Vedere sotto la tabella per esemplificazioni

Warning: the real absorbed current by the motor can be different from the one written on the nameplate.

PLN19-8 = max 6 A

PLN20 = max 22 A

PLN40 = max 44 A

See the table below for quick reference

Codice motore Motor code	Corrente motore Motor current <b>S1</b>	Scheda-Drive (servizio motore-motor duty) <b>S1</b>	Corrente motore Motor current <b>S2</b>	Scheda-Drive (servizio motore-motor duty) <b>S2</b>
<b>EC020.120</b>	3.2	PLN19-8 – PLN20	4	PLN19-8 – PLN20
<b>EC020.240</b>	1.5	PLN19-8 – PLN20	2	PLN19-8 - PLN20
<b>EC035.120</b>	5.2	PLN19-8 – PLN20	8	PLN20
<b>EC035.240</b>	2.6	PLN19-8 - PLN20	4	PLN19-8 - PLN20
<b>EC050.120</b>	6.8	PLN20	9.4	PLN20
<b>EC050.240</b>	3.4	PLN19-8 - PLN20	4.7	PLN19-8 - PLN20
<b>EC070.120</b>	8.4	PLN20	11.8	PLN20
<b>EC070.240</b>	4.2	PLN19-8 - PLN20	5.9	PLN19-8 - PLN20
<b>EC100.120</b>	12	PLN20	16.8	PLN20
<b>EC100.240</b>	6	PLN19-8 - PLN20	8.4	PLN20
<b>EC100.24E</b>	6	PLN19-8 - PLN20	8.4	PLN20
<b>ND100.120</b>	13.9	PLN20	19	PLN20
<b>ND100.240</b>	6.9	PLN20	9.0	PLN20
<b>EC180.120</b>	21.5	PLN20	30	PLN40
<b>EC180.240</b>	10.8	PLN20	15	PLN20
<b>EC180.24E</b>	10.8	PLN20	15	PLN20
<b>ND180.120</b>	20	PLN20	30	PLN40
<b>ND180.240</b>	10	PLN20	14	PLN20
<b>EC250.120</b>	30	PLN40	39	PLN40
<b>EC250.240</b>	15	PLN20	19.5	PLN20
<b>EC350.240</b>	21	PLN20	29.4	PLN40
<b>EC350.240BR</b>				
<b>EC600.240</b>	35.5	PLN40	47	PLN40
<b>EC600.240BR</b>				

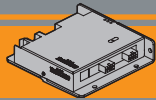

# Note/Notes



Neodymium

Ferrite

## Motoriduttori CC a vite senza fine DC wormgearmotors

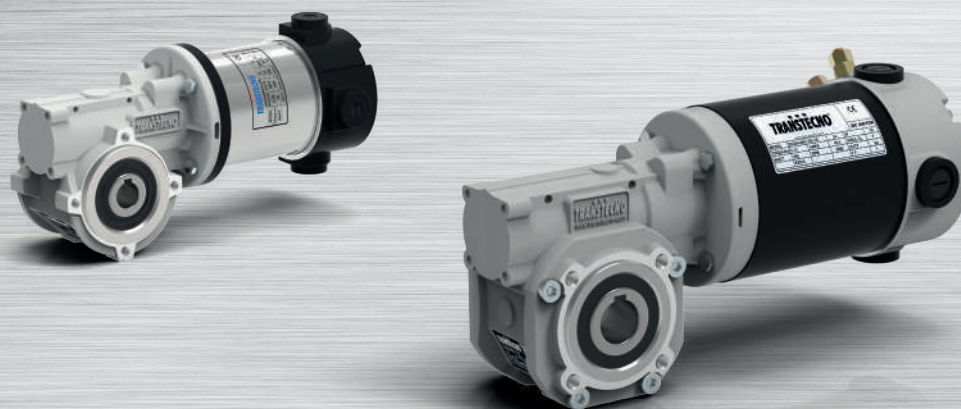



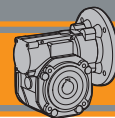

<b>Indice</b>	<b>Index</b>	Pag. Page
Caratteristiche tecniche	<i>Technical features</i>	<b>S2</b>
Designazione	<i>Classification</i>	<b>S2</b>
Sensi di rotazione	<i>Direction of rotation</i>	<b>S2</b>
Simbologia	<i>Symbols</i>	<b>S3</b>
Lubrificazione	<i>Lubrication</i>	<b>S3</b>
Carichi radiali	<i>Radial loads</i>	<b>S3</b>
Dati di dentatura	<i>Toothing data</i>	<b>S4</b>
Rendimento	<i>Efficiency</i>	<b>S4</b>
Motori applicabili	<i>IEC Motor adapters</i>	<b>S5</b>
Dimensioni	<i>Dimensions</i>	<b>S6</b>
Accessori	<i>Accessories</i>	<b>S12</b>
Opzioni	<i>Options</i>	<b>S13</b>

Questa sezione annulla e sostituisce ogni precedente edizione o revisione. Qualora questa sezione non Vi sia giunta in distribuzione controllata, l'aggiornamento dei dati ivi contenuto non è assicurato. **In tal caso la versione più aggiornata è disponibile sul nostro sito internet [www.transtecno.com](http://www.transtecno.com)**

*This section replaces any previous edition and revision. If you obtained this catalogue other than through controlled distribution channels, the most up to date content is not guaranteed. **In this case the latest version is available on our web site [www.transtecno.com](http://www.transtecno.com)***

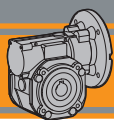

## Caratteristiche tecniche

## Technical features

L'elevata modularità contraddistingue i motoriduttori a vite senza fine della serie CL: i diversi kit entrata ed uscita li rendono estremamente versatili.

The high degree of modularity is a design feature of CL wormgearmotors range thanks to a wide selection of input and output kits. Main features of CL range are:

Le caratteristiche principali della serie CL sono:

- Carcassa in alluminio
- Lubrificazione permanente con olio sintetico
- Die-cast aluminium housing
- Permanent synthetic oil long life lubrication

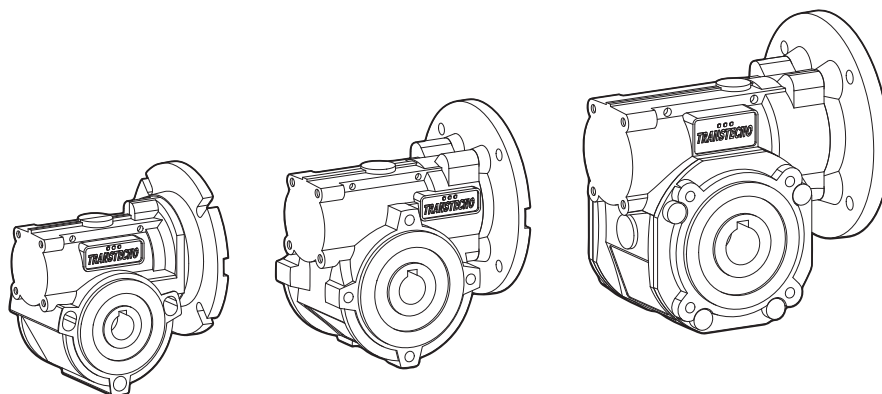

## Designazione

## Classification

### RIDUTTORI A VITE SENZA FINE / WORMGEARBOXES

RIDUTTORE / GEARBOX										
CL	030	U	10	63	B14	SZDX	BRSX	90	VS	SC
Tipo Type	Grandezza Size	Versione riduttore Gearbox Version	Rapporto Ratio	IEC	Forma costruttiva Version	Albero di uscita Output shaft	Braccio di reazione Torque arm	Angolo Angle	Opzioni Options	Accessori Accessories
	026 030 040 050 063 070	U F...	Vedere tabella See tables	56.. — 100/112	IEC B5 B14	SZDX SZSX DZ	BRDX BRSX *	0° 90° 180° 270°	VS**	SC Safety cover WD Washdown cover

Versione Riduttore Gearbox Version

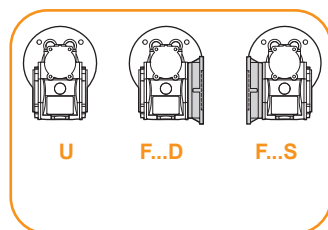

Albero di uscita Output shaft

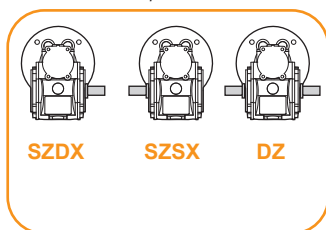

Braccio di reazione Torque arm \*

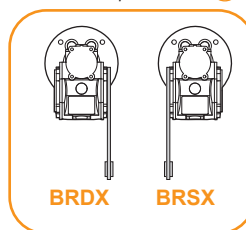

Angolo Angle

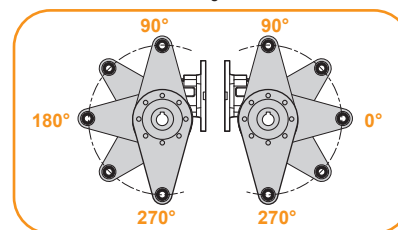

\* NOTA: il braccio di reazione viene fornito smontato.  
NOTE: the torque arm will be supplied not assembled.

\*\* NOTA: Vite sporgente costruita su richiesta  
NOTE: Extended input shaft built on request

## Sensi di rotazione

## Direction of rotation

CL

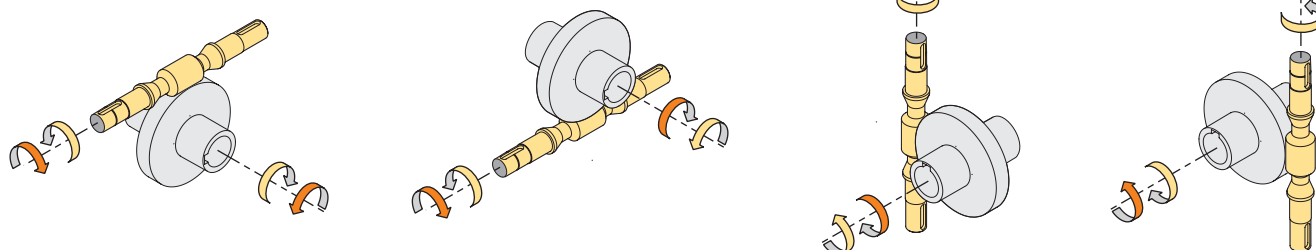

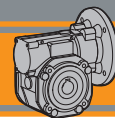

**Simbologia**

**Symbols**

$n_1$ [min <sup>-1</sup> ]	Velocità in ingresso / <i>Input speed</i>	sf	Fattore di servizio / <i>Service factor</i>
$n_2$ [min <sup>-1</sup> ]	Velocità in uscita / <i>Output speed</i>	Rd %	Rendimento dinamico / <i>Dynamic efficiency</i>
i	Rapporto di riduzione / <i>Ratio</i>	Rs %	Rendimento statico / <i>Static efficiency</i>
$P_1$ [kW]	Potenza in entrata / <i>Nominal input power</i>	$R_2$ [N]	Carico radiale ammissibile in uscita / <i>Permitted output radial load</i>
$M_2$ [Nm]	Coppia in uscita in funzione di $P_1$ / <i>Output torque referred to <math>P_1</math></i>	$A_2$ [N]	Carico assiale ammissibile in uscita / <i>Permitted output axial load</i>
$Pn_1$ [kW]	Potenza nominale in entrata / <i>Nominal input power</i>	Z	Numero di principi della vite / <i>Worm starts</i>
$Mn_2$ [Nm]	Coppia nominale in uscita in funzione di $Pn_1$ / <i>Nominal output torque referred to <math>Pn_1</math></i>	$\beta$	Angolo d'elica / <i>Helix angle</i>

**Lubrificazione**

**Lubrication**

Tutti i motoriduttori sono forniti completi di lubrificante sintetico viscosità 320, pertanto possono essere installati in qualunque posizione di montaggio e non necessitano di manutenzione.

*Permanent synthetic oil long-life lubrication (viscosity grade 320) makes it possible to use the gearmotors in all mounting positions; for this reason they can be installed in any assembly position and do not require maintenance.*

**Carichi radiali**

**Radial loads**

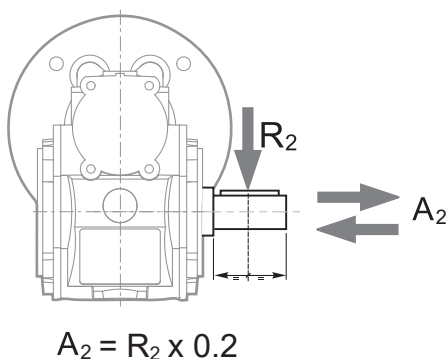

$n_2$ [min <sup>-1</sup> ]	$R_2$ [N]					
	CL026	CL030	CL040	CL050	CL063	CL070
187	400	674	1264	1770	2445	2613
140	490	743	1392	1949	2692	2878
93	580	851	1596	2234	3085	3298
70	610	936	1754	2456	3392	3626
56	610	1008	1890	2646	3654	3906
47	610	1069	2004	2805	3874	4141
35	610	1179	2210	3095	4273	4568
28	610	1270	2381	3334	4603	4921
23	610	1356	2542	3559	4915	5254
18	610	1471	2759	3862	5334	5702
14	610	1600	3000	4200	5800	6200

Quando il carico radiale risultante non è applicato sulla mezzzeria dell'albero occorre calcolare quello effettivo con la seguente formula:

*When the resulting radial load is not applied on the centre line of the shaft it is necessary to calculate the effective load with the following formula:*

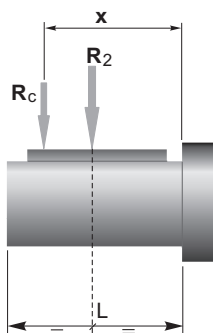

	CL	CL / CLP				
	026	030	040	050	063	070
a	56	65	84	101	120	122
b	43	50	64	76	95	92
$R_{2MAX}$	610	1600	3000	4200	5800	6200

$$R_c = \frac{R_2 \cdot a}{(b+x)} \leq R_{2MAX}$$

*a, b = valori riportati nella tabella  
a, b = values given in the table*

$$R \leq R_c$$

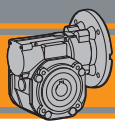

**CL**

**Motoriduttori a vite senza fine**  
**Wormgearmotors**

**Dati di dentatura**

**Toothing data**

	Dati della coppia vite-corona Worm wheel data	Rapporto / Ratio											
		5	7.5	10	15	20	25	30	40	50	60	80	100
CL026	Z	6	4	3	2	2		1	1	1	1		
	$\beta$	34° 35'	24° 41'	19° 1'	12° 57'	10° 30'		6° 33'	5° 17'	4° 26'	3° 49'		
CL030	Z	6	4	3	2	2	2	1	1	1	1	1	1
	$\beta$	27° 4'	24° 28'	18° 50'	12° 49'	10° 23'	8° 43'	6° 29'	5° 14'	4° 23'	3° 46'	2° 57'	2° 25'
CL040	Z	6	4	3	2	2	2	1	1	1	1	1	1
	$\beta$	34° 19'	24° 28'	18° 50'	12° 49'	10° 23'	8° 43'	6° 29'	5° 14'	4° 23'	3° 46'	2° 57'	2° 25'
CL050	Z	6	4	3	2	2	2	1	1	1	1	1	1
	$\beta$	33° 37'	23° 54'	18° 23'	12° 29'	10° 6'	8° 28'	6° 19'	5° 5'	4° 15'	3° 39'	2° 51'	2° 20'
CL063	Z	6	4	3	2	2	2	1	1	1	1	1	1
	$\beta$	34° 23'	24° 31'	18° 53'	12° 50'	10° 24'	8° 44'	6° 30'	5° 14'	4° 23'	3° 47'	2° 57'	2° 25'
CL070	Z		4	3	2	2	2	1	1	1	1	1	1
	$\beta$		26° 12'	20° 15'	13° 49'	11° 15'	9° 29'	7° 0'	5° 41'	4° 46'	4° 7'	3° 13'	2° 39'

**Rendimento**

**Efficiency**

	$n_1$ [min <sup>-1</sup> ]	Rendimento Efficiency	Rapporto / Ratio											
			5	7.5	10	15	20	25	30	40	50	60	80	100
CL026	2800	Rd	89	87	85	83	80		73	68	64	60		
	1400		87	84	83	78	74		66	61	57	53		
	900		84	83	80	75	71		61	57	52	48		
			Rs	72	71	68	61	56	46	41	36	34		
CL030	2800	Rd	89	88	86	84	81	78	74	70	65	62	57	52
	1400		86	85	84	79	75	72	67	62	58	55	48	43
	900		84	83	81	75	71	68	62	58	53	49	43	39
			Rs	72	67	63	55	50	43	39	35	31	27	23
CL040	2800	Rd	90	89	87	84	83	80	77	73	69	66	60	56
	1400		88	86	84	81	78	74	70	65	60	58	52	46
	900		86	84	82	77	74	70	66	60	57	53	46	41
			Rs	74	71	67	60	55	51	45	40	36	32	28
CL050	2800	Rd	91	90	88	86	84	82	78	74	71	68	62	58
	1400		89	87	85	82	79	76	72	67	63	60	54	49
	900		87	85	84	79	75	72	68	62	59	55	48	43
			Rs	73	70	66	59	55	51	44	39	35	32	27
CL063	2800	Rd	91	90	88	86	84	83	79	76	73	70	65	60
	1400		90	88	86	84	81	78	75	70	66	63	57	52
	900		89	86	84	81	78	75	70	65	61	58	52	47
			Rs	73	71	67	60	55	51	45	40	36	33	28
CL070	2800	Rd		90	89	87	85	84	80	77	74	72	67	62
	1400			89	87	84	82	80	76	72	68	65	60	53
	900			87	85	82	79	77	72	67	63	60	54	49
			Rs		72	69	62	60	55	48	43	38	36	31



**Rendimento teorico del riduttore dopo il rodaggio**  
**Theoretical efficiency of the gearbox after the first running period**

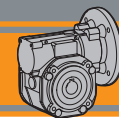

Motori applicabili

IEC Motor adapters

	IEC	N	M	P	D	i																	
						5	7.5	10	15	20	25	30	40	50	60	80	100						
CL026	56B14	50	65	80	9																		
CL030	63B5	95	115	140	11																		
	63B14	60	75	90																			
	56B5	80	100	120	9	B	B	B	B	B	B	B	B	B									
	56B14	50	65	80																			
CL040	71B5	110	130	160	14																		
	71B14	70	85	105																			
	63B5	95	115	140	11	B	B	B	B	B	B	B	B										
	63B14	60	75	90																			
	56B5	80	100	120	9	BS	BS	BS	BS	BS	BS	BS	BS	B	B	B	B						
	56B14	50	65	80																			
CL050	80B5	130	165	200	19																		
	80B14	80	100	120																			
	71B5	110	130	160	14	B	B	B	B	B	B	B											
	71B14	70	85	105																			
	63B5	95	115	140	11	BS	BS	BS	BS	BS	BS	BS	B	B	B	B							
	63B14	60	75	90																			
CL063	90B5	130	165	200	24																		
	90B14	95	115	140																			
	80B5	130	165	200	19	B	B	B	B	B	B	B											
	80B14	80	100	120																			
	71B5	110	130	160	14	BS	BS	BS	BS	BS	BS	BS	B	B	B								
	71B14	70	85	105																			
	63B5	95	115	140	11								BS	BS	BS	B	B						
CL070	100/112B5	180	215	250	28																		
	100/112B14	110	130	160																			
	90B5	130	165	200	24		B	B	B	B													
	90B14	95	115	140																			
	80B5	130	165	200	19		BS	BS	BS	BS	B	B	B										
	80B14	80	100	120																			
	71B5	110	130	160	14						BS	BS	BS	B	B	B	B						

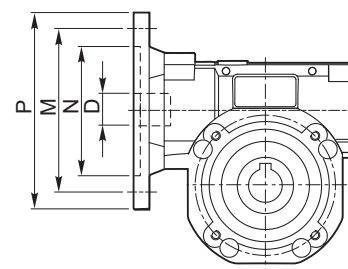

N.B.

Le aree evidenziate in grigio indicano l'applicabilità della corrispondente grandezza motore.

N.B. Grey areas indicate motor inputs available on each size of unit.

**B/BS = Boccola di riduzione in acciaio**

**B/BS = Metal shaft sleeve**

**Nota:** flange Nema disponibili a richiesta  
**Note:** Nema flange available on demand

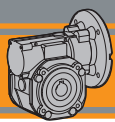

**CL**

Motoriduttori a vite senza fine  
Wormgearmotors

**Dimensioni**

**Dimensions**

**CL 026 U**

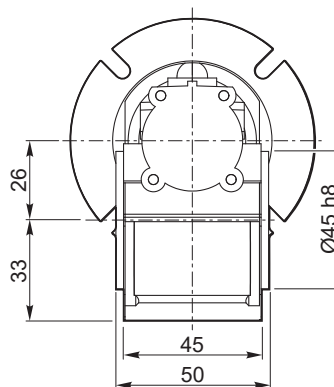
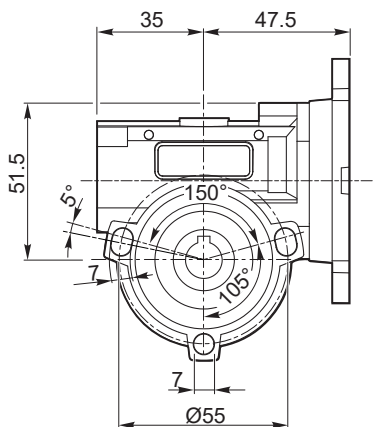

**Kg**  
0.7

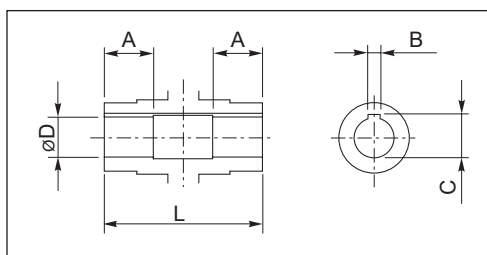

Albero lento cavo / Hollow output shaft

Grandezza Size	Ø D H8	L	A	B	C
CL 026	12	50	15	4	13.8

**CL 026 F**

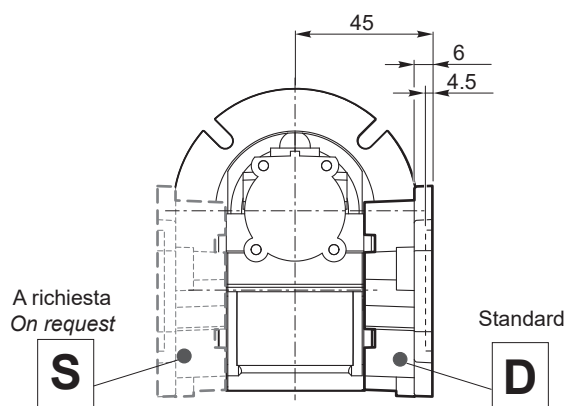
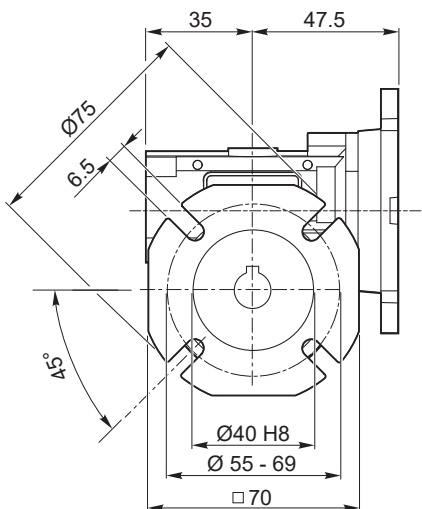

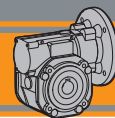

Dimensioni

Dimensions

CL 030 U

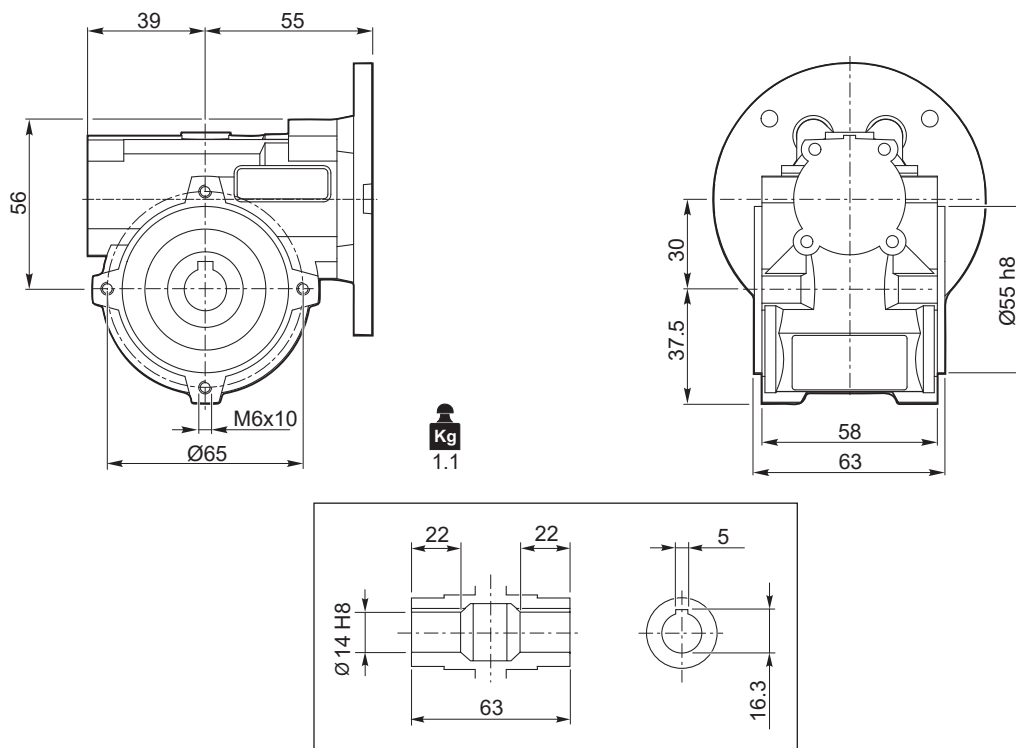

Albero lento cavo / Hollow output shaft

CL 030 F

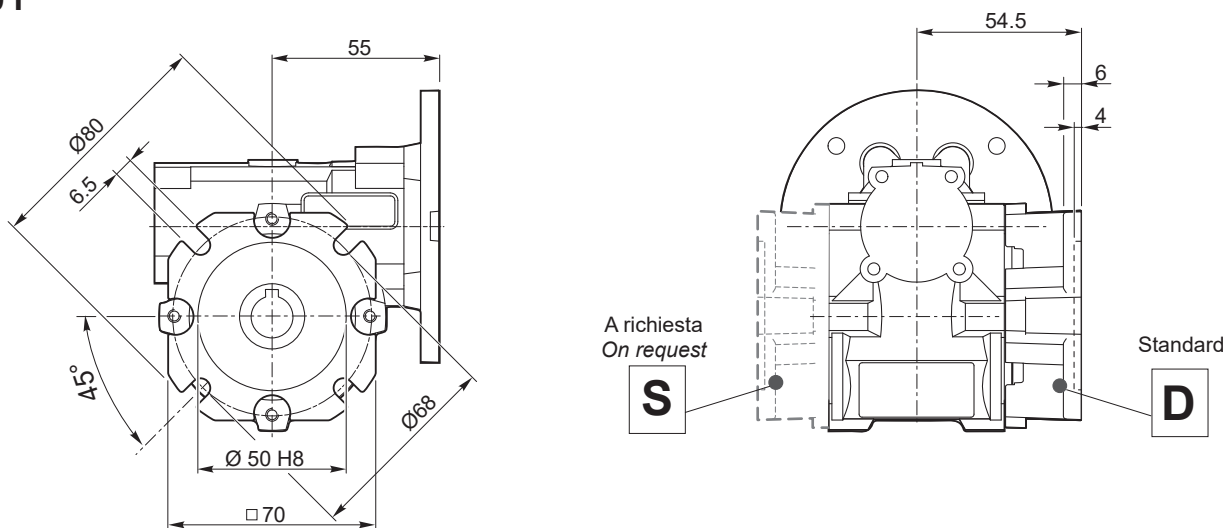

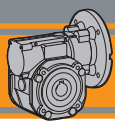
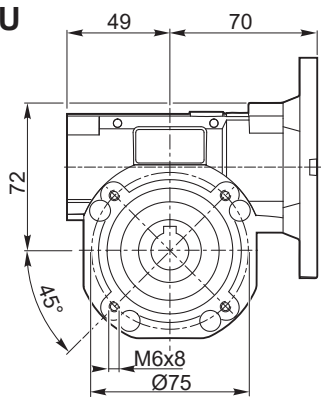
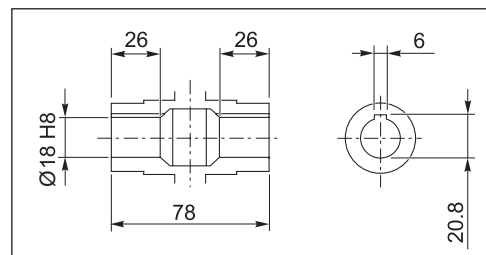
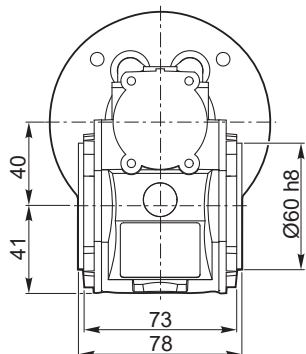
**CL****Motoriduttori a vite senza fine**  
**Wormgearmotors****Dimensioni****Dimensions****CL 040 U****Kg**  
2.1

Albero lento cavo / Hollow output shaft

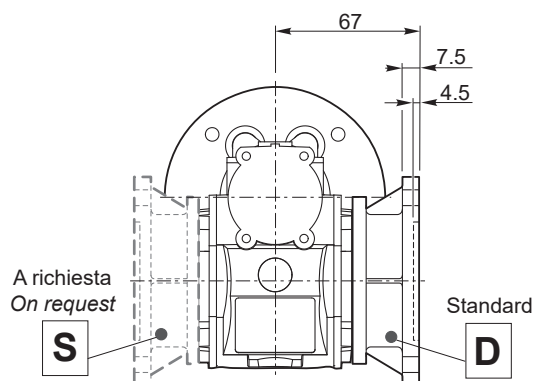
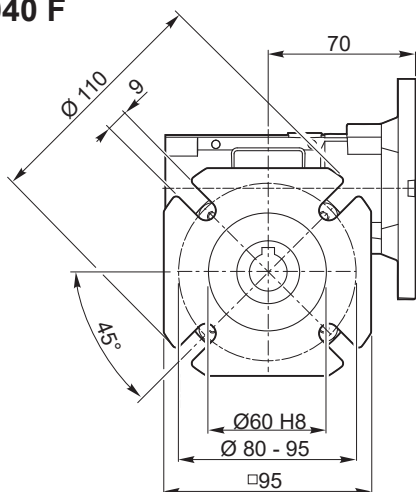
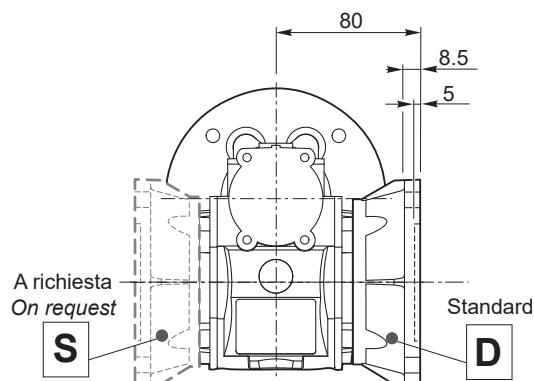
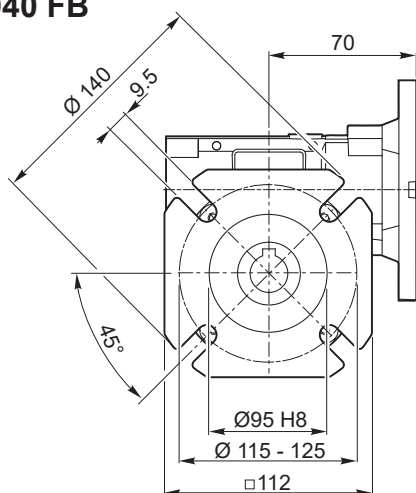
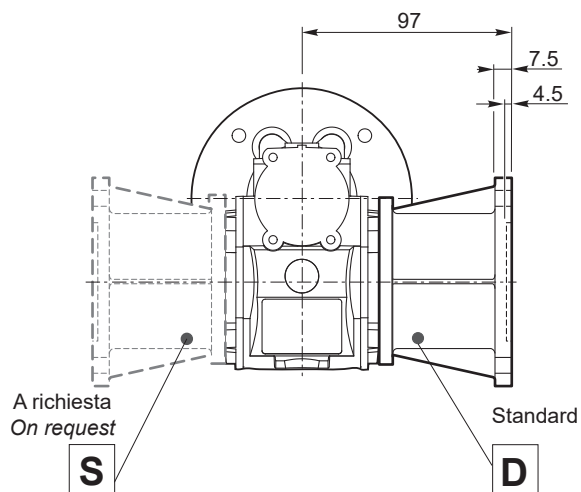
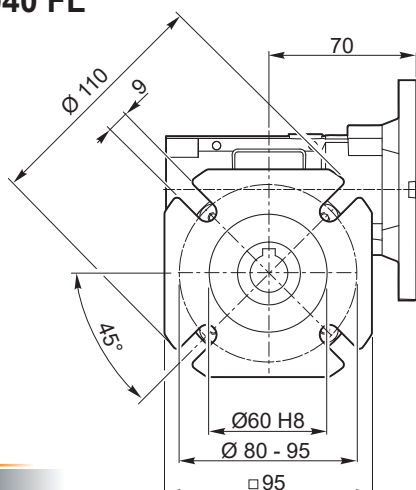
**CL 040 F****CL 040 FB****CL 040 FL**

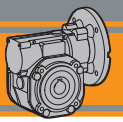

Dimensioni

Dimensions

CL 050 U

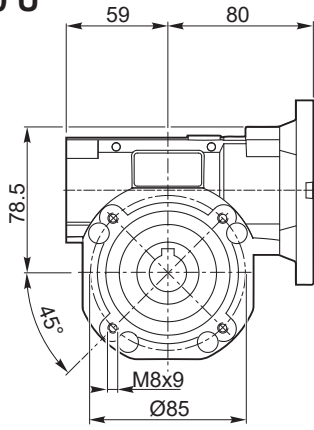

**Kg**  
3.3

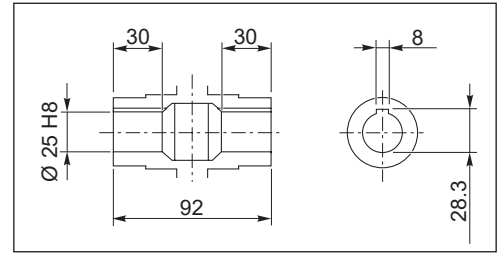
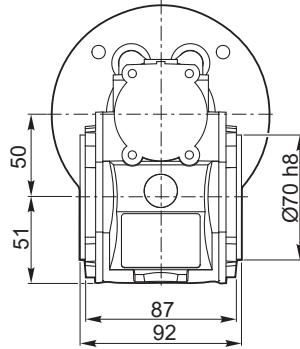

Albero lento cavo / Hollow output shaft

CL 050 F

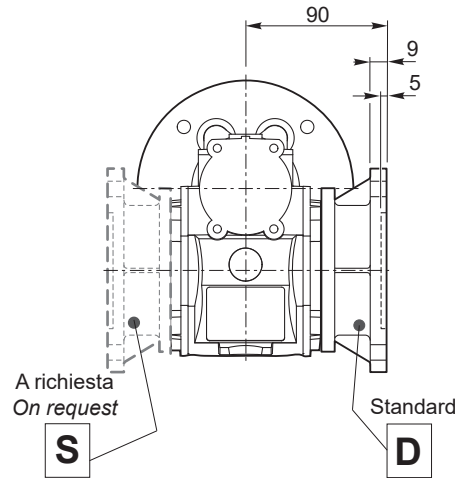
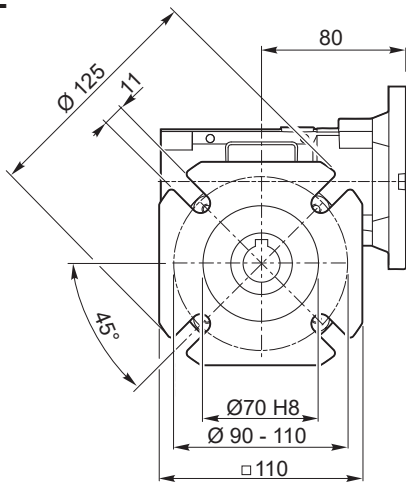

CL 050 FB

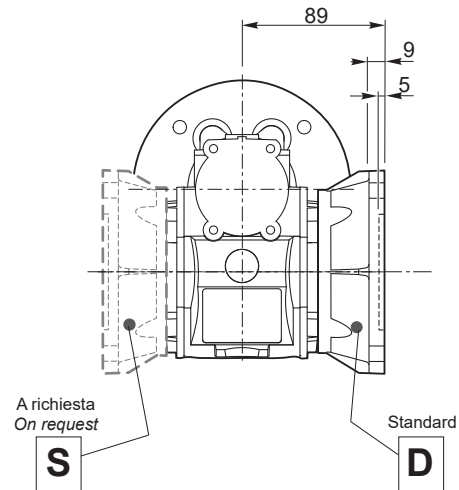
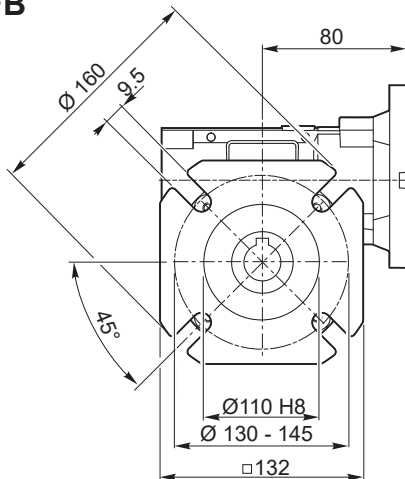

CL 050 FL

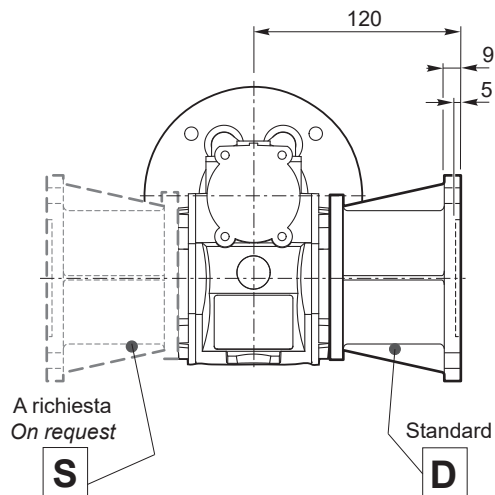
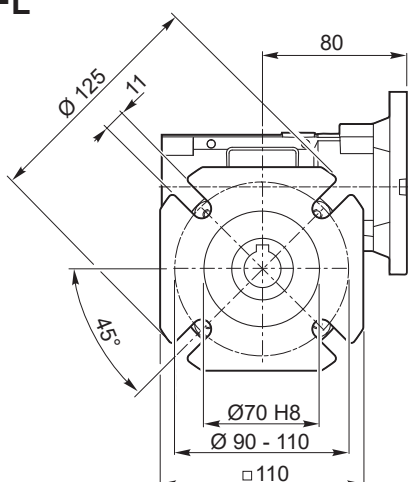

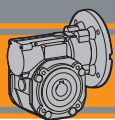
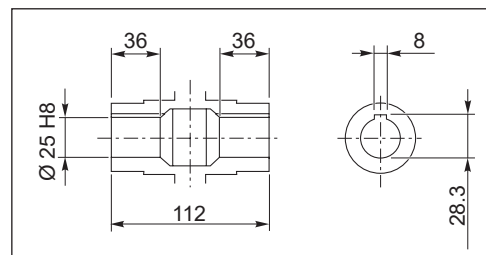
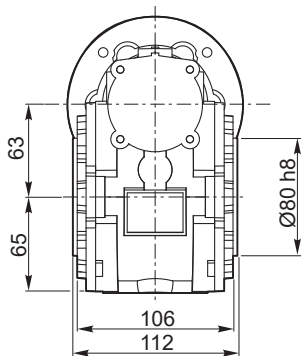
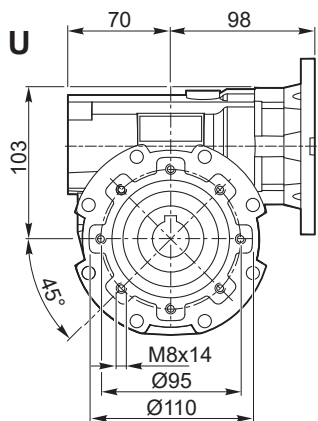
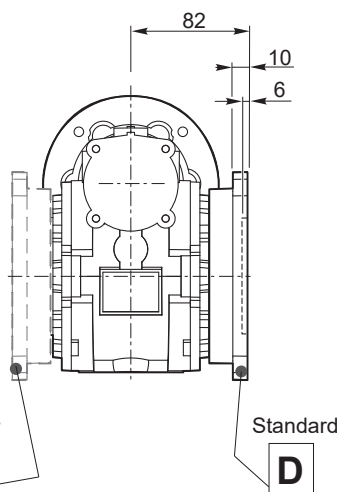
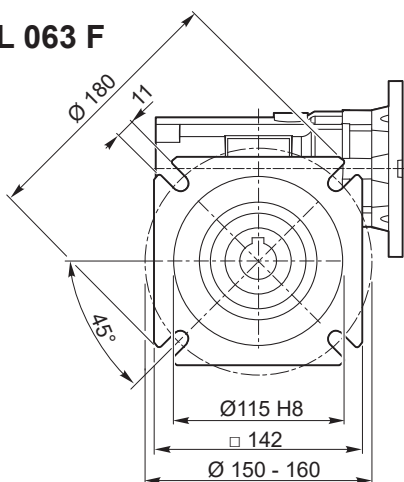
**CL****Motoriduttori a vite senza fine**  
**Wormgearmotors****Dimensioni****Dimensions****CL 063 U**Albero lento cavo / *Hollow output shaft***Kg**  
6.0**CL 063 F**A richiesta  
*On request*

Standard

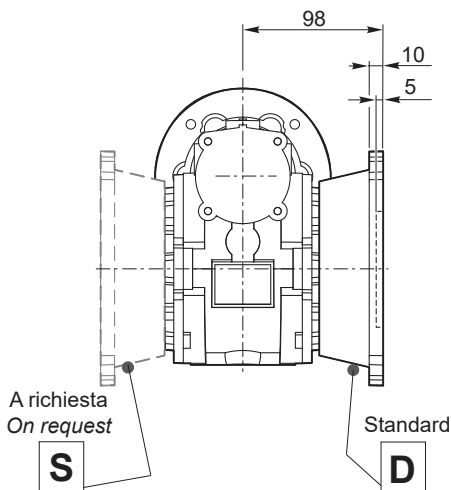
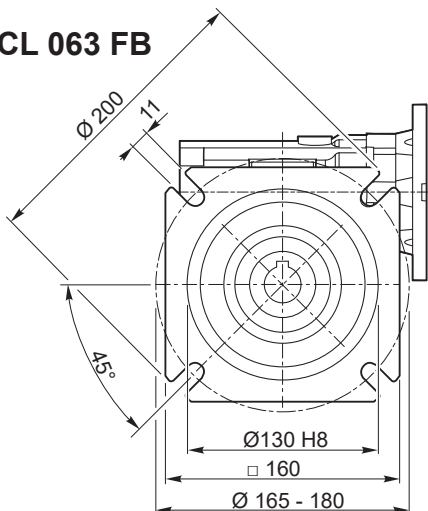
**CL 063 FB**A richiesta  
*On request*

Standard

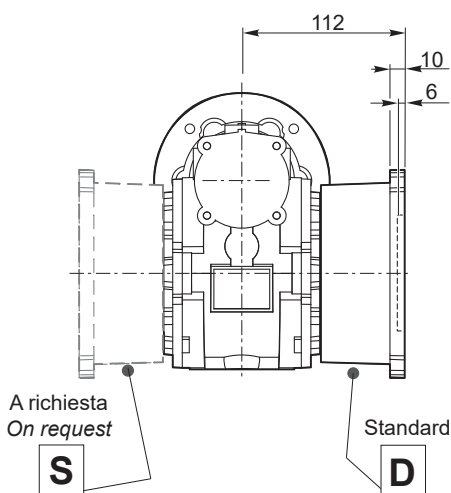
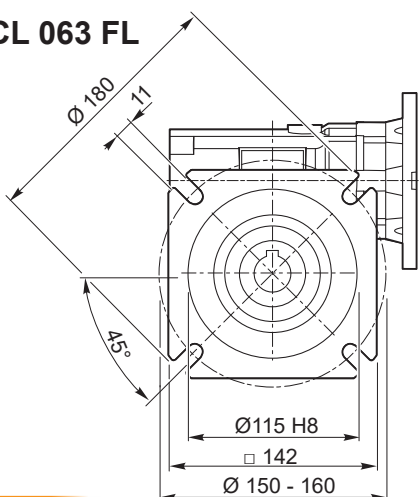
**CL 063 FL**A richiesta  
*On request*

Standard

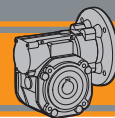

Dimensioni

Dimensions

CL 070 U

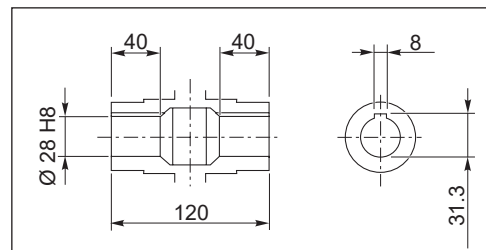
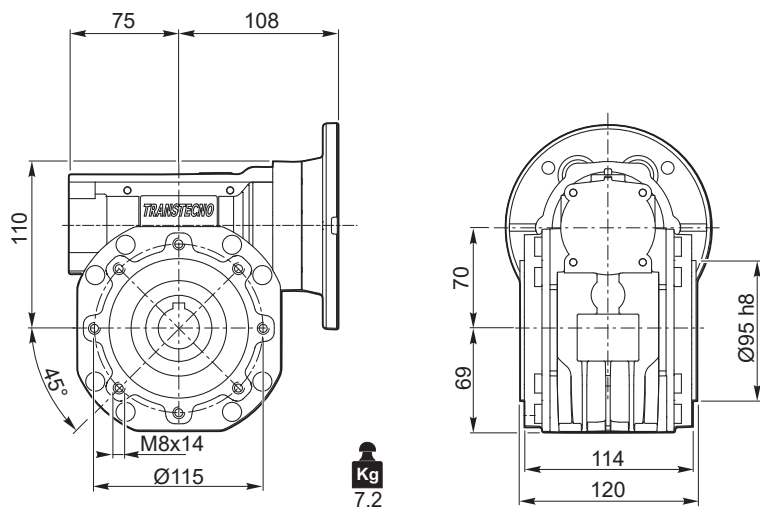

Albero lento cavo / Hollow output shaft

CL 070 F

CLP../070 F

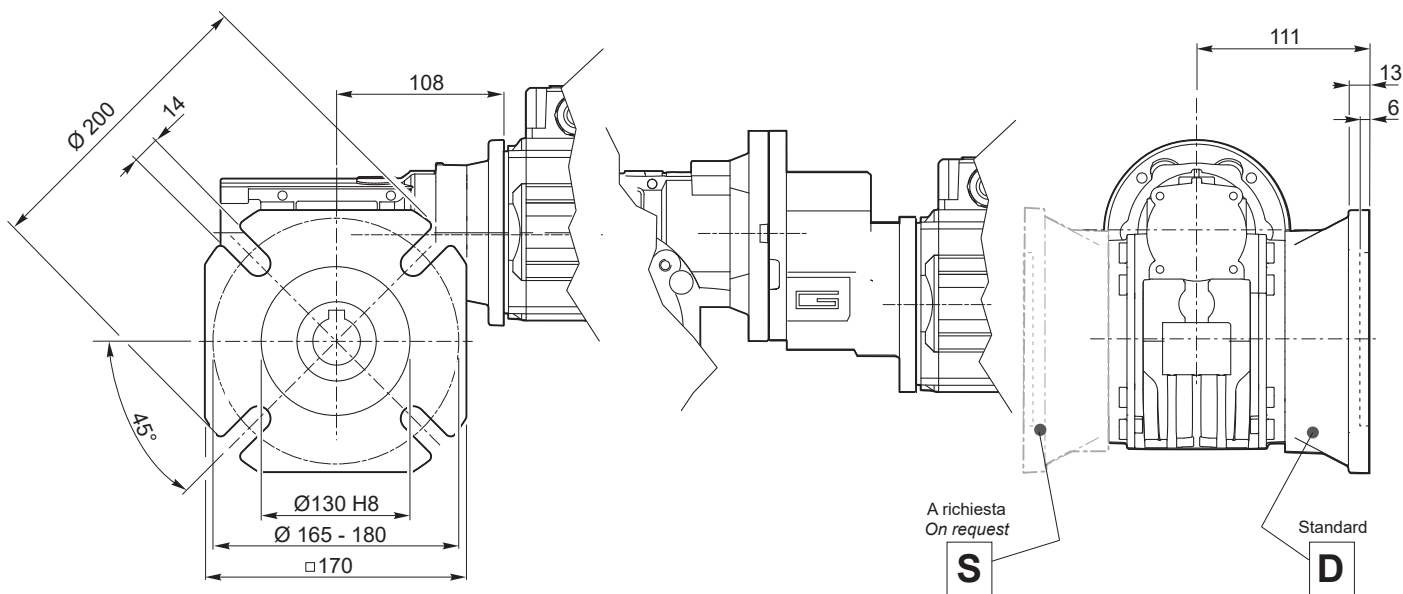

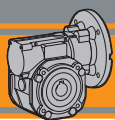

**Accessori**

**Accessories**

**Albero lento semplice e doppio**

**Single and double output shaft**

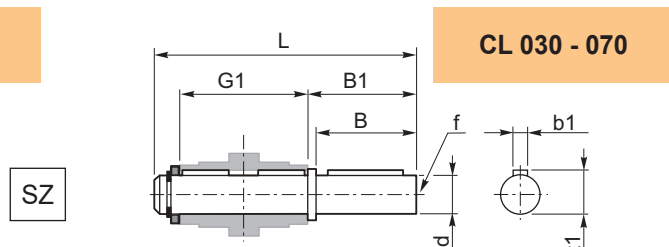
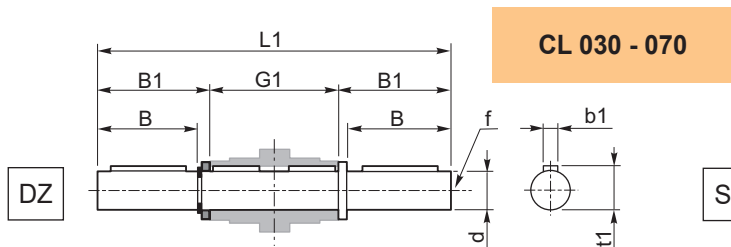

CL	d h7	B	B1	G1	L	L1	f	b1	t1
030	14	30	32.5	63	102	128	M6	5	16
040	18	40	43	78	128	164	M6	6	20.5
050	25	50	53.5	92	153	199	M10	8	28
063	25	50	53.5	112	173	219	M10	8	28
070	28	60	63.5	120	192	247	M10	8	31

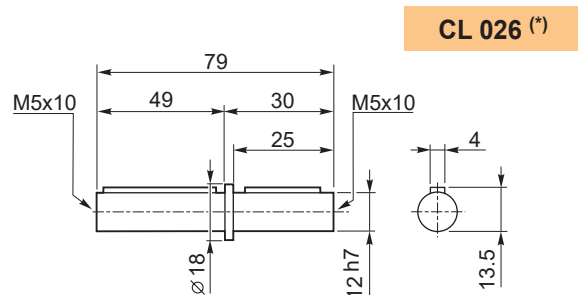

(\*)  
Nota: disponibile solo per cavo uscita Ø12  
Note: available for output hollow shaft Ø12 only

**Braccio di reazione**

**Torque arm**

CL	K1	G	KG	KH	R
030	85	14	23	8	15
040	100	14	31	10	18
050	100	14	38	10	18
063	150	14	47.5	10	18
070	200	25	46.5	20	30

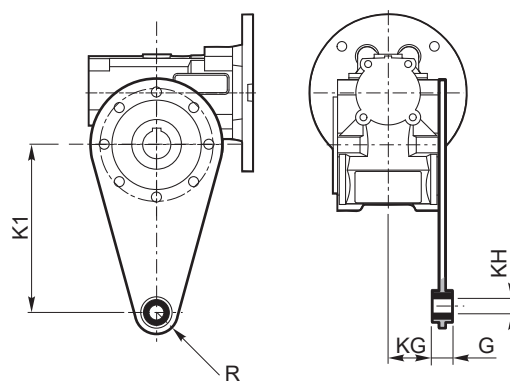

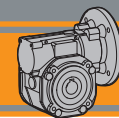

Accessori

Accessories

**SC** - Safety Cover

CL	M
030	47
040	54.5
050	62.5
063	73
070	75

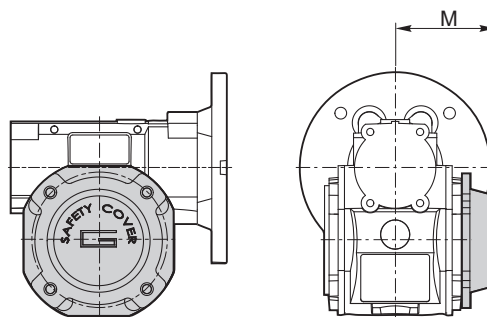

**WD** - Kit washdown cover

CL	M
026*	37.5
030	48
040	55.5
050	63.5
063	71.5
070	76

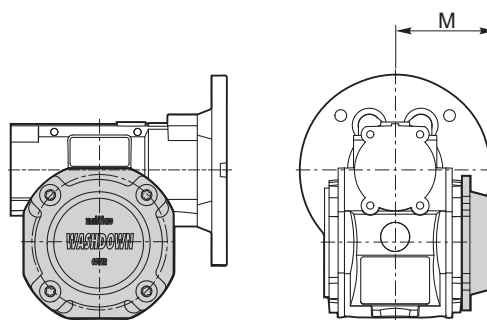

(\*)  
**Nota:** Viti escluse dalla fornitura  
**Note:** Screws not provided

Opzioni

Options

**VS** - Vite sporgente / Extended input shaft

CL	A	B	D <sub>1</sub> j6	E	F	G
030	45	20	9	M4	3	10.2
040	53	23	11	M5	4	12.5
050	64	30	14	M6	5	16
063	75	40	19	M6	6	21.5
070	84	40	19	M6	6	21.5

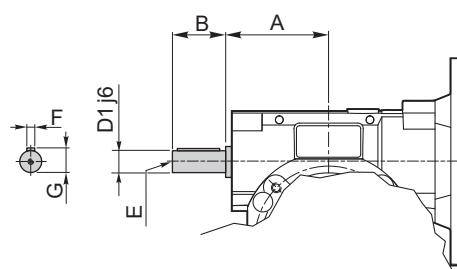

 Costruito su richiesta  
Built on request



 **TRANSTECNO SRL**  
**HEADQUARTERS**

Company subject to the management  
and coordination of INTERPUMP GROUP SPA  
Via Caduti di Sabbiano, 11  
40011 Anzola dell'Emilia (BO)  
ITALY  
T+39 051 64 25 811  
F +39 051 73 49 43  
sales@transtecno.com  
[www.transtecno.com](http://www.transtecno.com)

  
the modular gearmotor  
**MEMBER OF INTERPUMP GROUP**

CATALUDCFEB26A



 **HANGZHOU INTERPUMP  
POWER TRANSMISSIONS CO LTD**  
No.4 Xiuyan Road Fengdu Industry Zone  
Pingyao Town Yuhang District  
Hangzhou City, Zhejiang Province  
311115 – CHINA  
T +86 571 86 92 02 60  
info-china@transtecno.cn  
[www.transtecno.cn](http://www.transtecno.cn)

 **TRANSTECNO IBÉRICA  
THE MODULAR GEARMOTOR, S.A.**  
Carrer de la Ciència, 45  
08840 Viladecans (Barcelona) - SPAIN  
T +34 931 598 950  
info@transtecno.es  
[www.transtecno.es](http://www.transtecno.es)

 **TRANSTECNO B.V.**  
Siliciumweg 32  
3812 SX Amersfoort - NETHERLANDS  
T +31(0) 33 45 19 505  
info@transtecno.nl  
[www.transtecno.nl](http://www.transtecno.nl)

 **TRANSTECNO AANDRIJFTECHNIEK B.V.**  
Siliciumweg 32  
3812 SX Amersfoort - NETHERLANDS  
T +31 (0) 33 20 47 006  
info@transtecnoaandrijftechnik.nl  
[www.transtecnoaandrijftechnik.nl](http://www.transtecnoaandrijftechnik.nl)

 **MA TRANSTECNO S.A.P.I. DE C.V.**  
Julián Sepúlveda Dávila #107,  
Parque Industrial SG  
Apodaca, Nuevo León, CP. 66640  
MÉXICO  
T +52 8113340920  
info@transtecno.com.mx  
[www.transtecno.com.mx](http://www.transtecno.com.mx)

 **TRANSTECNO USA**  
8 Creek Parkway,  
Boothwyn PA 19061-8136 - UNITED STATES  
T + 1 (610) 4970154

**TRANSTECNO USA – WEST COAST BRANCH**  
14561 Frylandts Blvd SE  
Monroe, WA 98272 - UNITED STATES  
T +1 360-863-1300  
usaoffice@transtecno.com  
[www.transtecno.com](http://www.transtecno.com)

 **TRANSTECNO CANADA**  
51 B Caldari Road Unit 10  
Vaughan, ON L4K 4G3 - CANADA  
T +1 905 761 0762  
canadaoffice@transtecno.com  
[www.transtecno.com](http://www.transtecno.com)

 **TRANSTECNO INDIA**  
#6A, Sipcot Industrial complex, Phase-1,Elasagiri Road  
Hosur – 635126 Tamilnadu - INDIA  
T +91 4344 274434  
M +91 81443 88800  
indiaoffice@transtecno.com  
[www.transtecno.com](http://www.transtecno.com)

 **INTERPUMP ANTRIEBSTECHNIK GMBH**  
Büro Stuttgart - Dieselstraße 6  
70738 Fellbach - GERMANY  
T +49 (0)171 4781909  
germanoffice@transtecno.com  
[www.transtecno.com](http://www.transtecno.com)

 **TRANSTECNO BRAZIL**  
Rua Gilberto de Zorzi, 525 Forqueta - CEP. 95115-730  
CX Postal 3544 Caxias do Sul RS – BRAZIL

**TRANSTECNO BRAZIL – SÃO PAULO BRANCH**  
Rua Fortunato Jose Deltreggia, 745 – CEP: 13347-441  
Indaiatuba, São Paulo – BRAZIL  
T +55 19 98927 3906

**TRANSTECNO BRAZIL – PORTO ALEGRE BRANCH**  
Rua Dr. Freire Alemão 155 / 402 - CEP. 90450-060  
Auxiliadora Porto Alegre RS - BRAZIL  
T +55 51 4042 0916  
M +55 51 811 45 962  
braziloffice@transtecno.com  
[www.transtecno.com.br](http://www.transtecno.com.br)

 **TRANSTECNO AUSTRALIA**  
1/2 Access Way, Carrum Downs, Victoria, 3201  
AUSTRALIA  
T +61 (03) 9775 1077  
australiaoffice@transtecno.com  
[www.transtecno.com](http://www.transtecno.com)

 **SALES OFFICE OCEANIA**  
Unit 5, 12 Nyholt Drive, Yatala 4207  
Queensland - AUSTRALIA  
T +61 07 3800 0103  
M +61 04 38060997  
UNIT 9 , 94 Boundary Rd, Sunshine West 3020  
Victoria - AUSTRALIA  
T + 61 03 9312 4722  
oceaniaoffice@transtecno.com  
[www.transtecno.com.au](http://www.transtecno.com.au)