

Technische Daten				
Nennspannung	U_N	[Volt]	24	
Leerlaufdrehzahl	n_0	[min ⁻¹]	38	
Nenn Drehmoment	M_N	[Nm]	3,00	
Einschaltdauer		%		
Ein		[min]		
Anlaufmoment	M_A	[Nm]	16,00	
Getriebeübersetzung			55:1	
Ankerwiderstand	2Lamellen	R	mOhm	3400
	4Lamellen	R	mOhm	300
Zahnradwerkstoff			Kunststoff	
Hall IC				
Impulse/Umdrehung Antriebswelle				
Ausgangskanäle				
Bemerkung				
Schutzart				
Gewicht		[kg]	1,2	

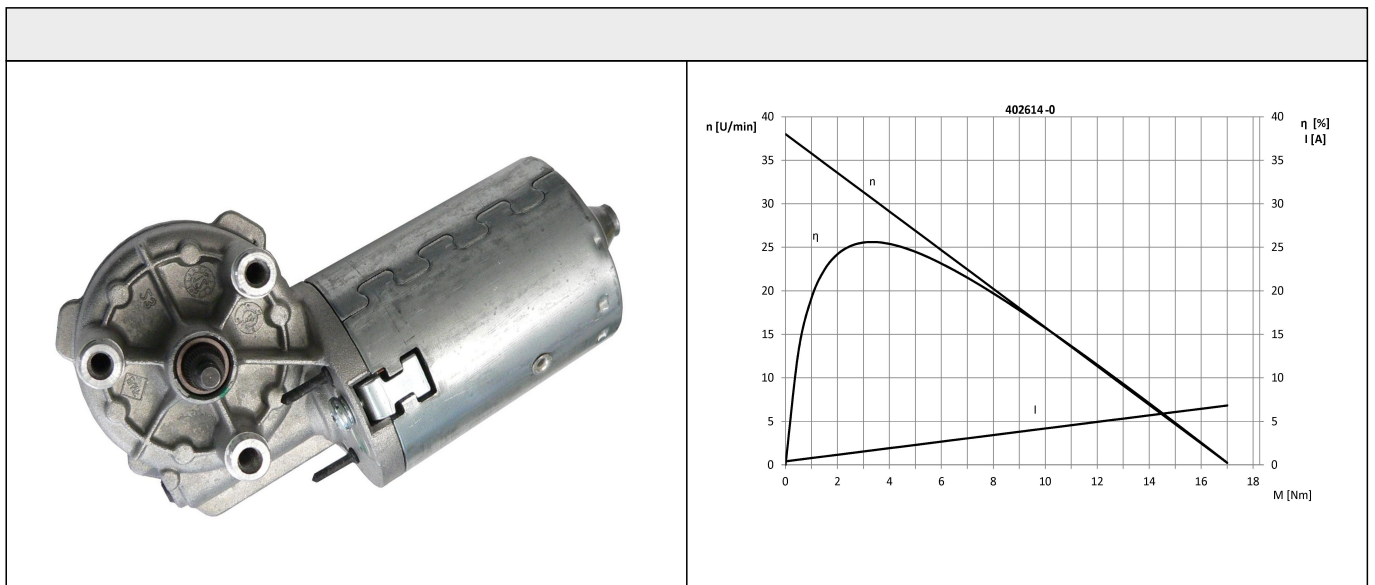

Abtriebswelle W41

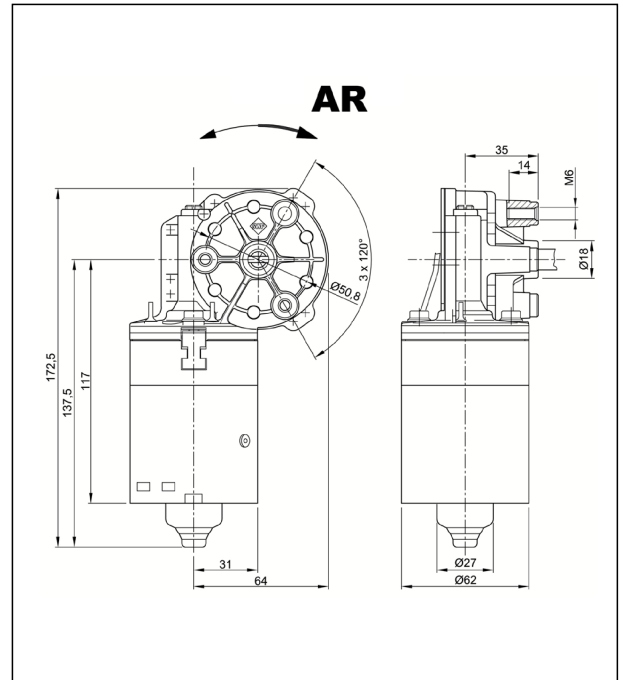
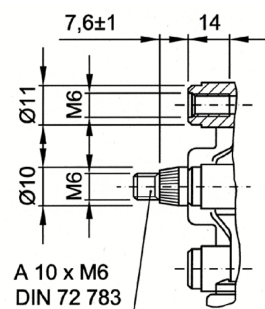

Schaltbild S27

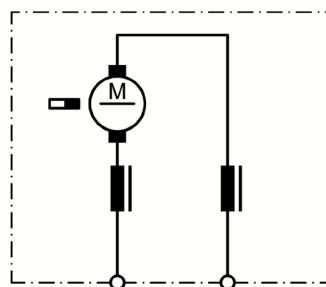

Anschluss K191

