

Technische Daten			
Nennspannung	U_N	[Volt]	12
Leerlaufdrehzahl	n_0	[min ⁻¹]	21
Nenn Drehmoment	M_N	[Nm]	4,00
Einschaltdauer		%	
Ein		[min]	
Anlaufmoment	M_A	[Nm]	23,00
Getriebeübersetzung			69:1
Ankerwiderstand	2Lamellen	R	mOhm
	4Lamellen	R	mOhm
Zahnradwerkstoff			Kunststoff
Hall IC			
Impulse/Umdrehung Antriebswelle			
Ausgangskanäle			
Bemerkung			
Schutzart			IP30
Gewicht		[kg]	1,2

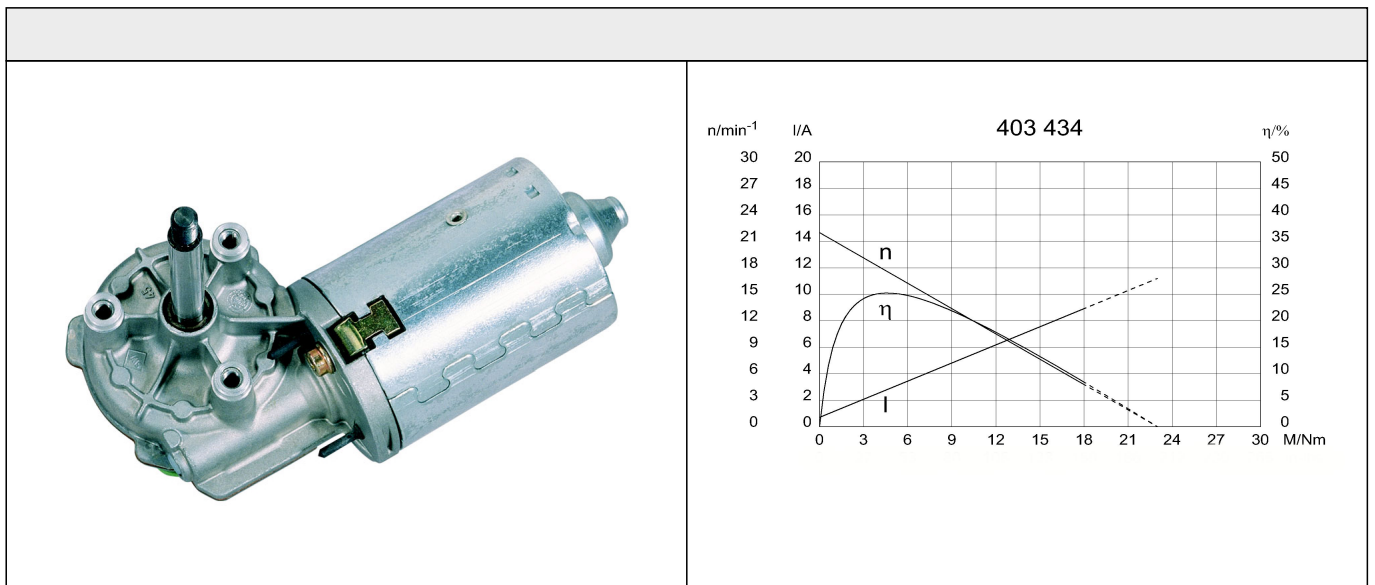

Abtriebswelle W120

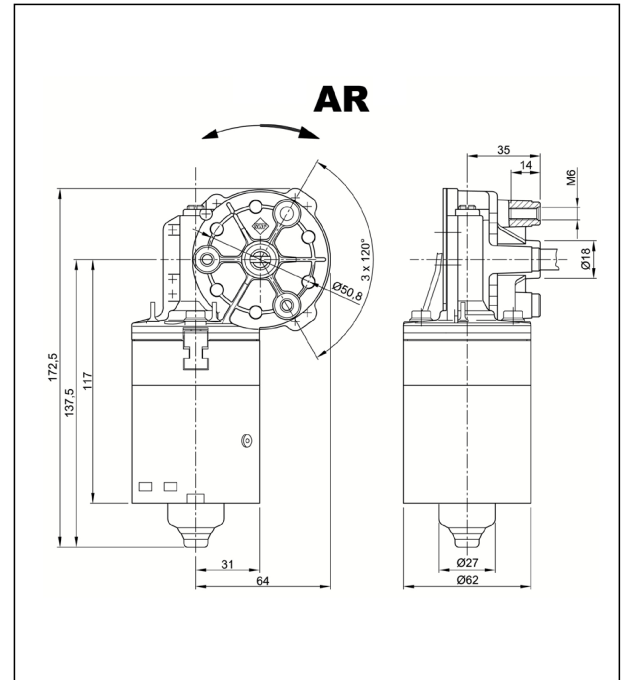
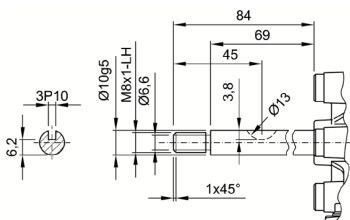

Schaltbild S75

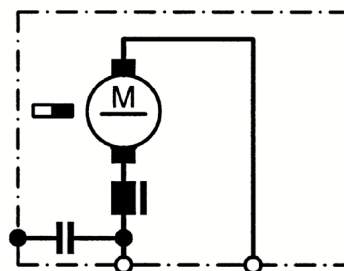

Anschluss K42

