

Baureihe 0270 (SWMK)

Motortyp 404 516

Technische Daten

Nennspannung	U_N	[Volt]	24	
Leerlaufdrehzahl	n_0	[min ⁻¹]	62	
Nenn Drehmoment	M_N	[Nm]	3,0	
Einschaltdauer		%		
EIN		[min]		
Anlaufmoment	M_A	[Nm]	57,0	
Getriebeübersetzung	i		69/1	
Anschlusswiderstand	2 Lamellen	R	[mΩ]	530,0
	4 Lamellen	R	[mΩ]	360,0
Anschlussinduktivität	2 Lamellen	L	[mH]	1,00
	4 Lamellen	L	[mH]	1,00
Läuferträgheitsmoment	J_R	[kgm ²] × 10 ⁻⁶	50,0	
Zahnradwerkstoff			Kunststoff	
Hall IC			X	
Impuls/Umdrehung Abtriebswelle			69	
	Ausgangskanäle		1	
Bemerkungen			ohne Kappe ; Kugellager	
Schutzart			IP 30	
Gewicht		[kg]	1,20	

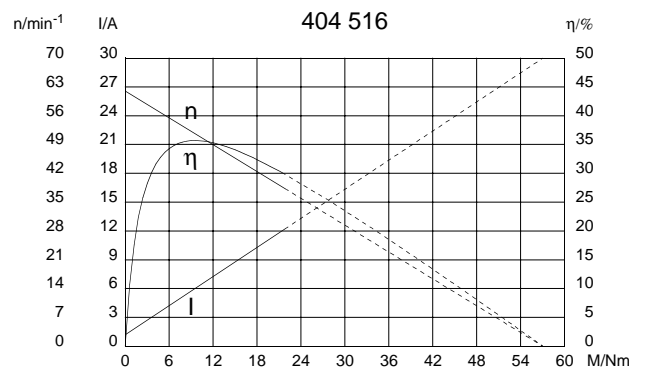
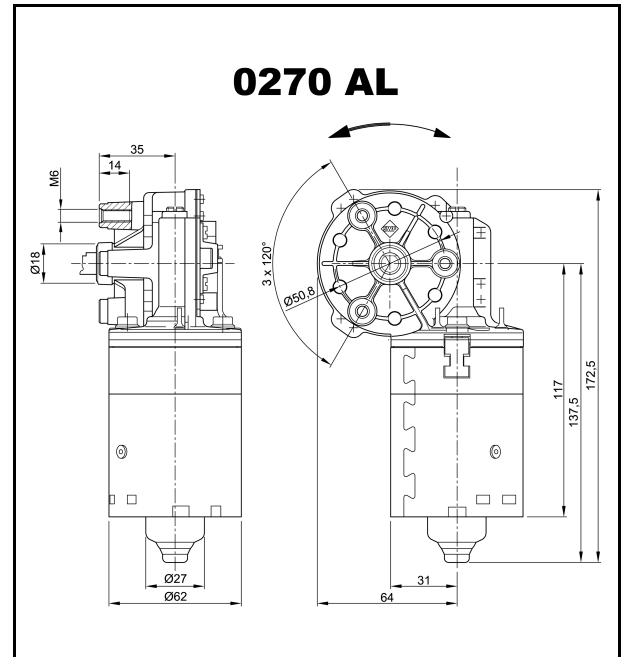

W 216

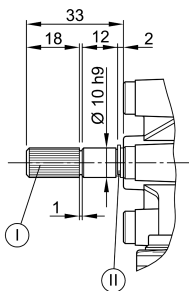

I Kerbverzahnung 8 x 10 DIN 5481

II Sicherungsring DIN 471

S 30

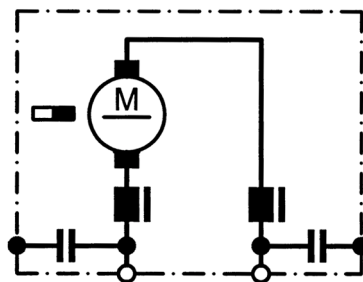

S 79

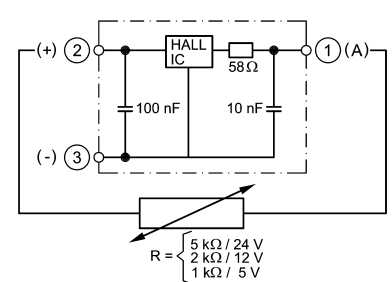

K 204

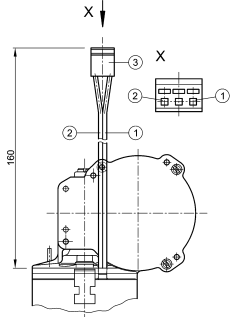

- I schwarz
- II rot
- III Steckergehäuse Molex-Nr.: 09-50-1031

K 54

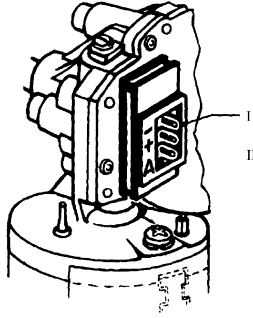

- I Panduit MLSS 100-03
- II Gegenstecker: Panduit CE 100 F22-03

Notizfeld: