

Technische Daten

Nennspannung	U_N	[Volt]	24
Leerlaufdrehzahl	n_0	[min ⁻¹]	14
Nenn Drehmoment	M_N	[Nm]	3,00
Einschaltdauer		%	
Ein		[min]	
Anlaufmoment	M_A	[Nm]	16,50
Getriebeübersetzung			78:1
Ankerwiderstand	2Lamellen	R	mOhm
	4Lamellen	R	mOhm
Zahnradwerkstoff			Bronze
Hall IC			X
Impulse/Umdrehung Antriebswelle			234
Ausgangskanäle			1
Bemerkung		d=für gewindeformende Schraube M6 DIN 7500	
Schutzart			IP30
Gewicht		[kg]	1,210

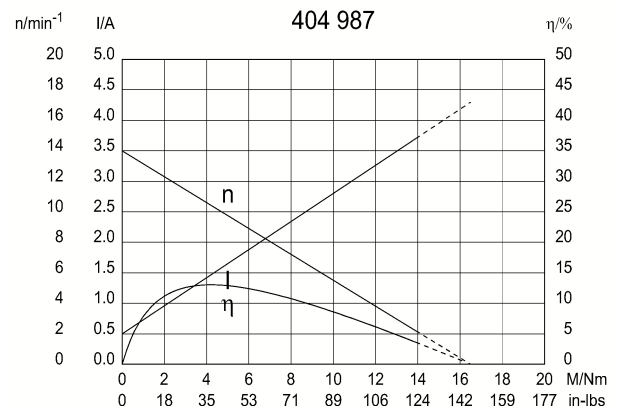

Abtriebswelle W327

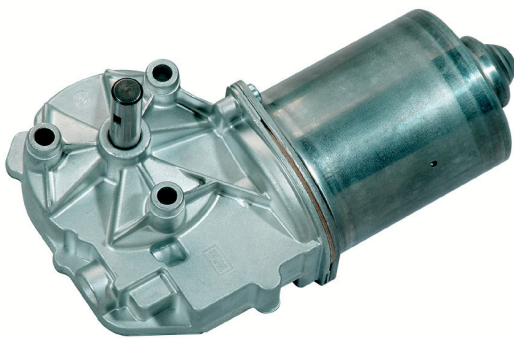
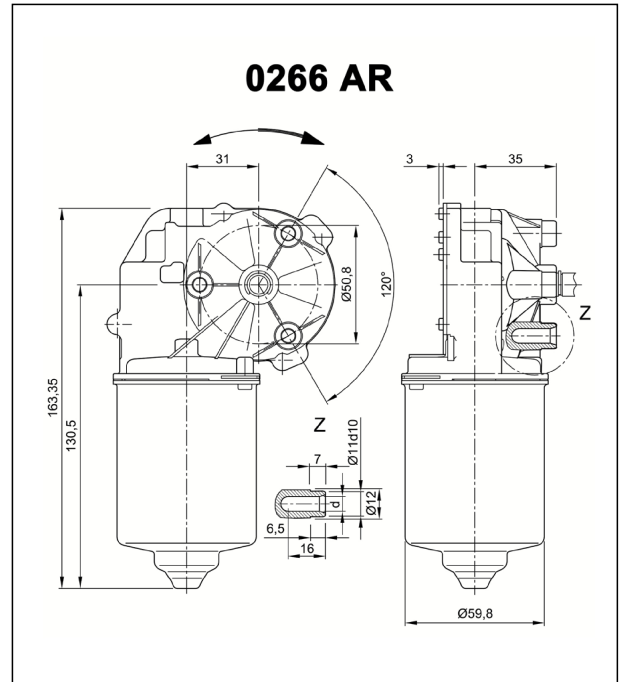
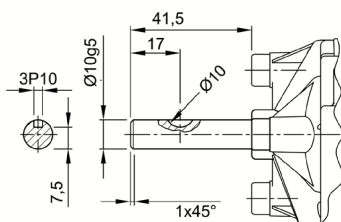

Schaltbild S27

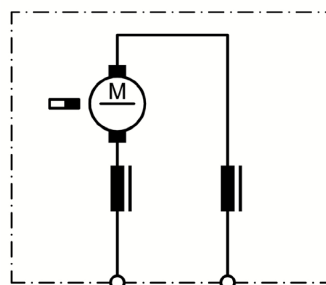

Anschluss K320

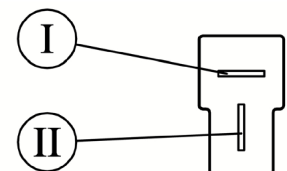

- I Flachstecker 6,3 x 0,8
DIN 46 244
- II Gegenstecker: Tyco 180907
mit Hülse AMP 925603

Hallgeber S124

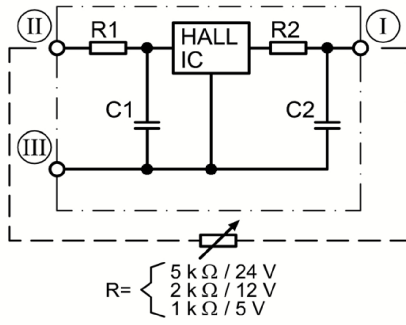

- I Stecker 3, A
- II Stecker 4, +
- III Stecker 5, -

Anschluß K326

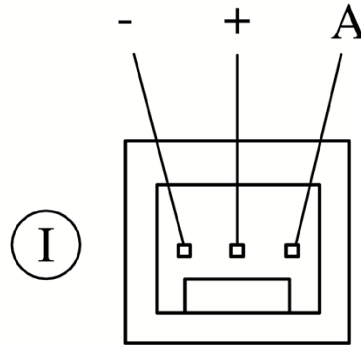

- I Gegenstecker: Panduit CE100 F22 - 03

Anschluß K321

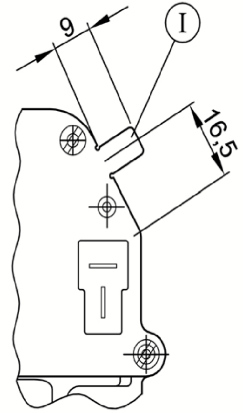

- I Masseanschluß
Flachstecker 6,3 x 0,8 DIN 46 244