

Technische Daten			
Nennspannung	U_N	[Volt]	24
Leerlaufdrehzahl	n_0	[min ⁻¹]	90
Nenn Drehmoment	M_N	[Nm]	4,00
Einschaltdauer		%	
Ein		[min]	
Anlaufmoment	M_A	[Nm]	20,00
Getriebeübersetzung			69:1
Ankerwiderstand	2Lamellen	R	mOhm
	4Lamellen	R	mOhm
Zahnradwerkstoff			Kunststoff
Hall IC			X
Impulse/Umdrehung Antriebswelle			69
Ausgangskanäle			2
Bemerkung			d=M6x10
Schutzart			IP30
Gewicht		[kg]	1,21

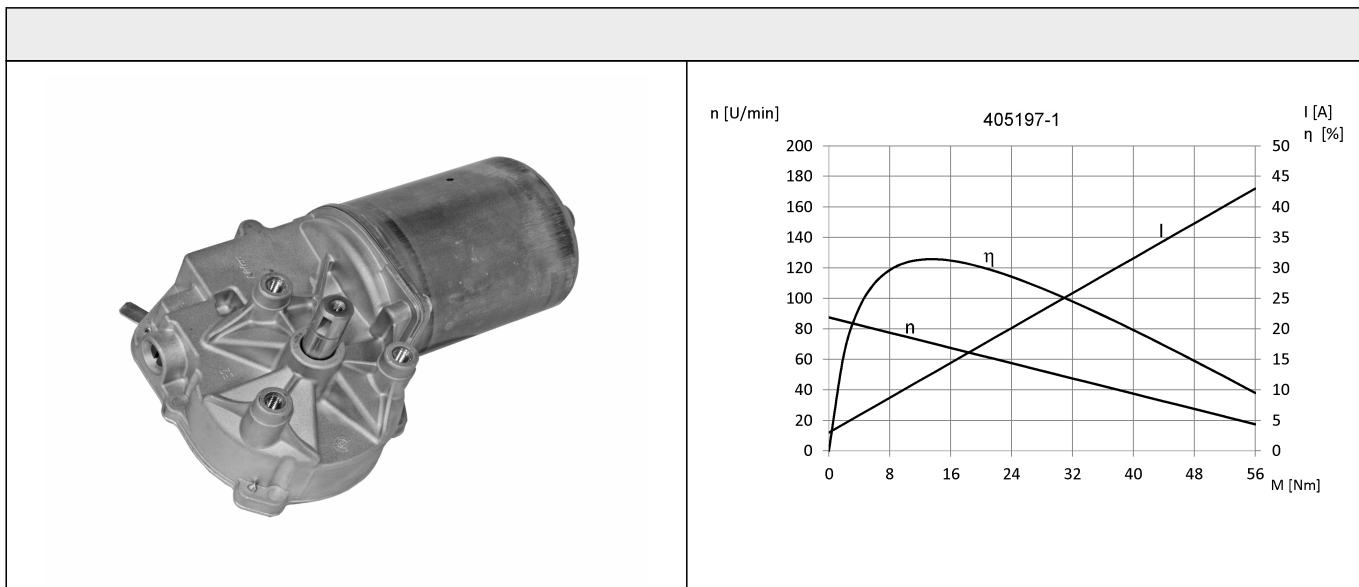

Abtriebswelle W304

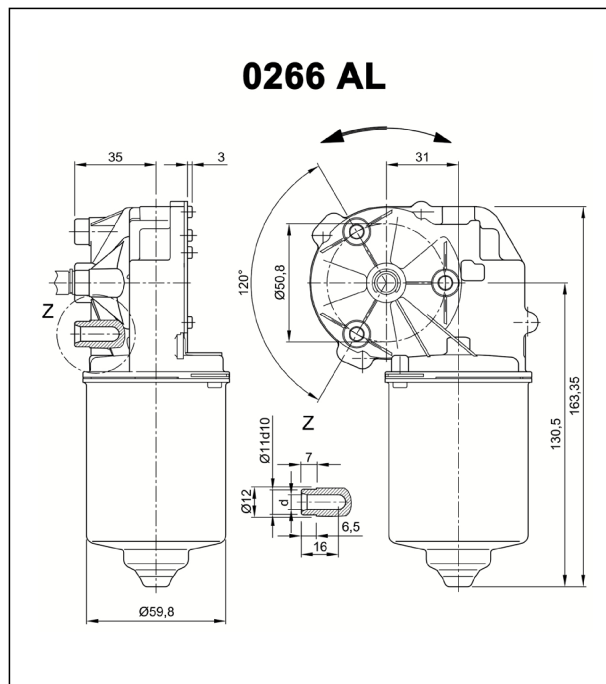
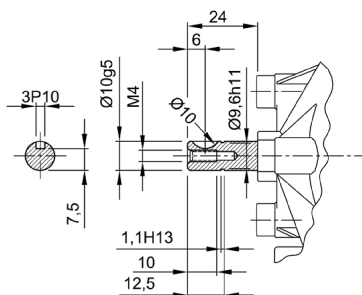

Schaltbild S30

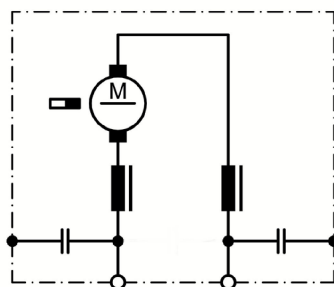

Anschluss K320

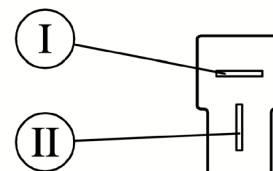

- I Flachstecker 6,3 x 0,8
DIN 46 244
- II Gegenstecker: Tyco 180907
mit Hülse AMP 925603

Hallgeber S-ESD

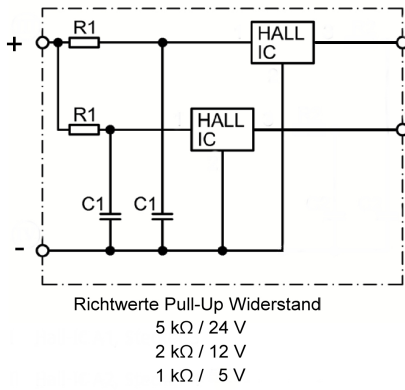

Anschluß K324

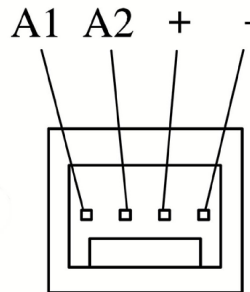

Gegenstecker: Panduit CF100 F22-04

Anschluß K312

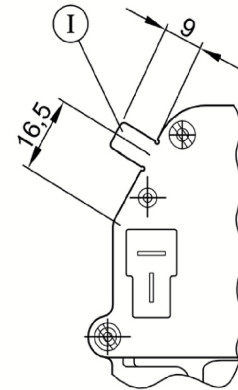

Masseanschluß
Flachstecker 6,3 x 0,8 DIN 46 244