

Technische Daten

Nennspannung	U_N	[Volt]	24
Leerlaufdrehzahl	n_0	[min ⁻¹]	72
Nenn Drehmoment	M_N	[Nm]	10,00
Einschaltdauer		%	
Ein		[min]	
Anlaufmoment	M_A	[Nm]	56,00
Getriebeübersetzung			59:1
Ankerwiderstand	2Lamellen	R	mOhm
	4Lamellen	R	mOhm
Zahnradwerkstoff			Hartgewebe
Hall IC			
Impulse/Umdrehung Antriebswelle			
Ausgangskanäle			
Bemerkung			
Schutzart			IP20
Gewicht		[kg]	2,9

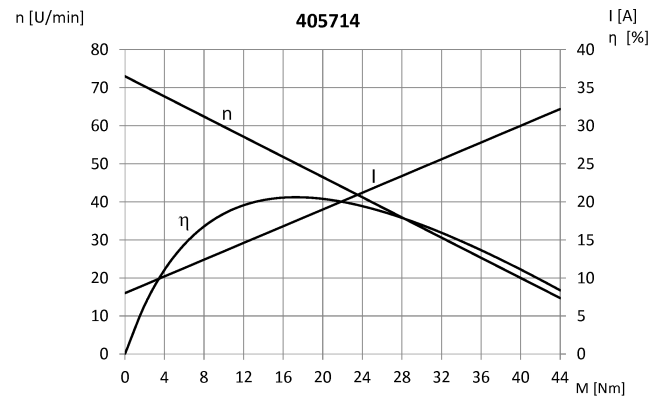

Abtriebswelle W61

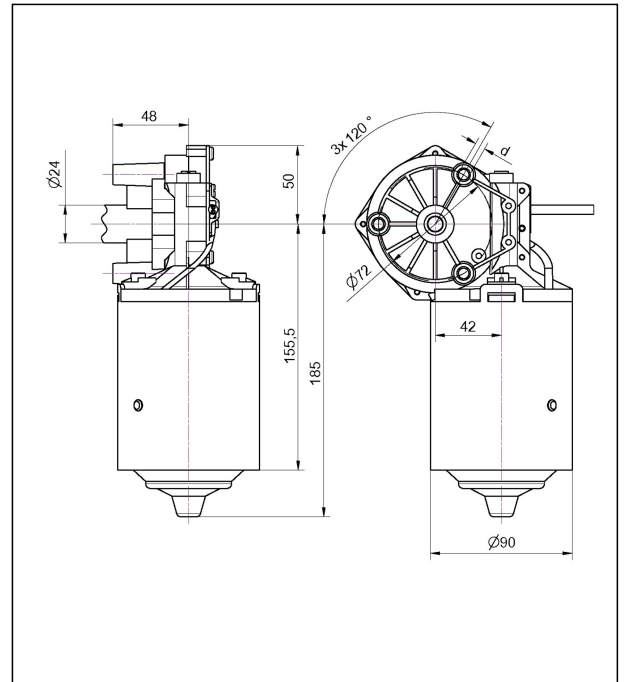
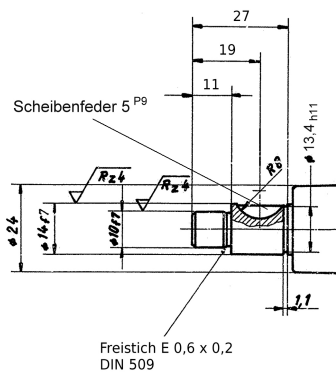

Schaltbild S27

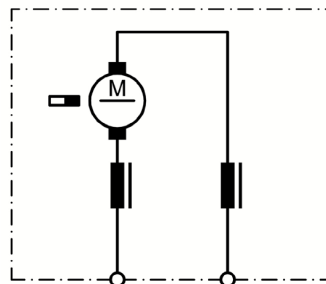

Anschluss K132

