



# Reversible Motor



Reversible Motor

## Index

<b>Outline of Reversible Motor</b>	<b>B-75</b>
<b>Reversible Motor 6W (□ 60mm)</b>	<b>B-77</b>
<b>Reversible Motor 6W (□ 70mm)</b>	<b>B-79</b>
<b>Reversible Motor 10W (□ 70mm)</b>	<b>B-81</b>
<b>Reversible Motor 15W (□ 70mm)</b>	<b>B-83</b>
<b>Reversible Motor 15W (□ 80mm)</b>	<b>B-85</b>
<b>Reversible Motor 25W (□ 80mm)</b>	<b>B-88</b>
<b>Reversible Motor 40W (□ 90mm)</b>	<b>B-91</b>
<b>Reversible Motor 60W (□ 90mm)</b>	<b>B-94</b>
<b>Reversible Motor 90W (□ 90mm)</b>	<b>B-98</b>
<b>Reversible Motor 120W (□ 90mm)</b>	<b>B-102</b>

DKM AC/DC Geared Motor and Gearbox **B-74**

Änderungen und Irrtümer auch technischer Art vorbehalten!

# B AC Motors

## Outline of Reversible Motor

### ☉ Suitable for Bi-directional Continuous Operation

- Reversible motors are designed for application where frequent switch of direction is required. It is capacitor run type and single phase induction motor. So its basic features including speed, torque and voltage are same with that of induction motors. For the function of frequent bi-directional operation within short time, the temporary brake is employed.

### ☉ The Rating Time: 30 Minutes

- Reversible motors are designed for bi-directional operation within short time so it can't avoid very high loss of input. So generally its temperature rising could be more severe than induction motor. As a result, the rated operating time could be limited to 30 minutes. But please be informed that depending on operating condition, they can be operated for more 30 minutes if it is operated intermittently.

### ☉ Brake Mechanism of the Reversible Motor

- A reversible motor employed a simple and built-in brake mechanism for the following purposes:
  - (1) To improve the frequent and instant reversing function by applying a friction load
  - (2) To reduce overrun
- The coil spring applies constant pressure so that the ceramic (brake block) slides toward the brake plate. This mechanism provides some degree of holding brake force, but there is limit in the force due to the mechanism's structure. The brake force is approximately 10% of the motor's output.

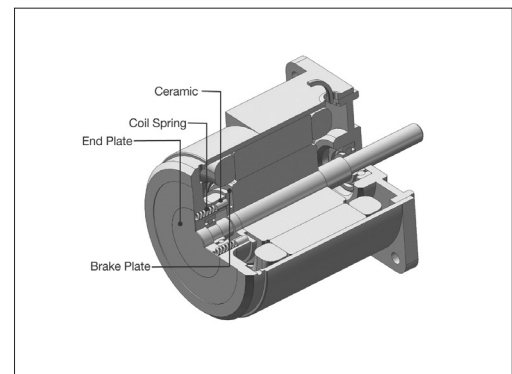

### ☉ Speed-Torque Characteristics

- The reversible motor is a single phase induction motor of capacitor run type which has the same characteristics as an induction motor. The reversible motor has a higher starting torque than an induction motor in order to improve the instant reversing characteristics.

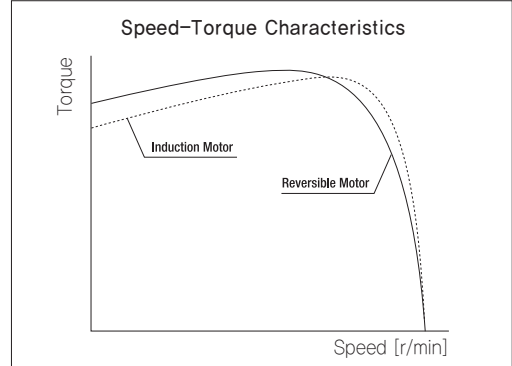

### ☉ Operation Time and Temperature Rise

- The rating time of reversible motor is 30 minutes. But when the motor is operated intermittently for a short period of time, the operation time may vary depending on the operating conditions. The intermittent operation for a short period of time will cause a considerable flow of electric current in starting or reversing causing greater heat generation. But the motor's temperature rise can be controlled by keeping the motor at rest without using for a longer time by enhancing its natural cooling capability. Generally if the temperature of motor case remains below 90°C constantly, the continuous operation is possible under unchanged condition considering insulation class of coil winding. But the life time of bearing grease will be much longer, the lower temperature.

### ☉ Operating Cycle and Temperature Rise

(Figure 1) Operating Cycle

	Run	Stop							
A	1 sec.	1 sec.	1 sec.						1 sec. run, 1 sec. stop
B									2 sec. run, 2 sec. stop
C									2 sec. run, 1 sec. stop
D									1 sec. CW run, 1 sec. CCW run, 1 sec. stop
E									2 sec. CW run, 1 sec. CCW run, 1 sec. stop
F									Continuous run

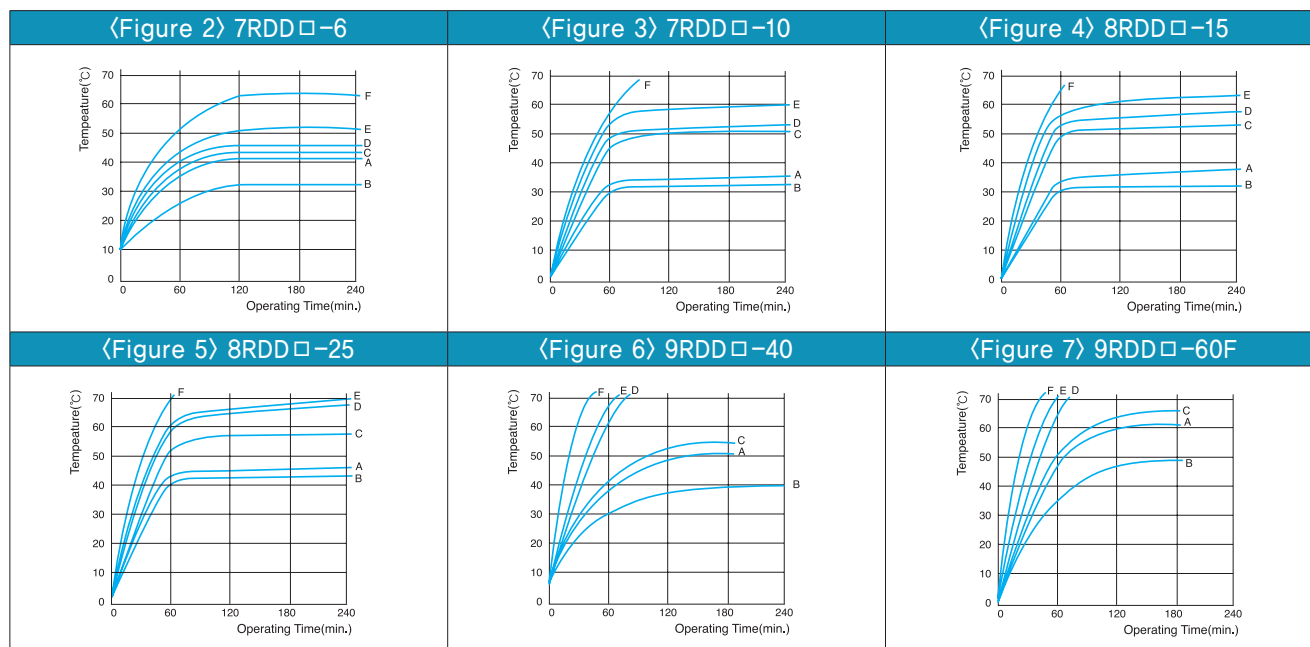

### General Specifications

Item	Specification
Insulation Resistance	100M $\Omega$ or more when DC500V MEGA is applied between the windings and the frame after rated motor operation under normal ambient temperature and humidity.
Dielectric Strength	Sufficient to withstand 1.5KV at 50Hz and 60Hz applied between the windings and the frame for 1 minute after rated motor operation under normal ambient temperature and humidity.
Temperature Rise	Temperature rise of windings are 80°C or less measured by the resistance change method after rated motor operation with connecting a Gearbox or equivalent heat radiation plate.
Insulation Class	Class B [130°C]
Overheat Protection	Operating temperature (Built-in thermal protector type motor): Open 120°C $\pm$ 5°C, Close 90°C $\pm$ 5°C
Ambient Temperature	-10°C~+40°C (Three phase 220VAC: -10°C~+50°C)
Ambient Humidity	85% maximum

### Connection Diagrams

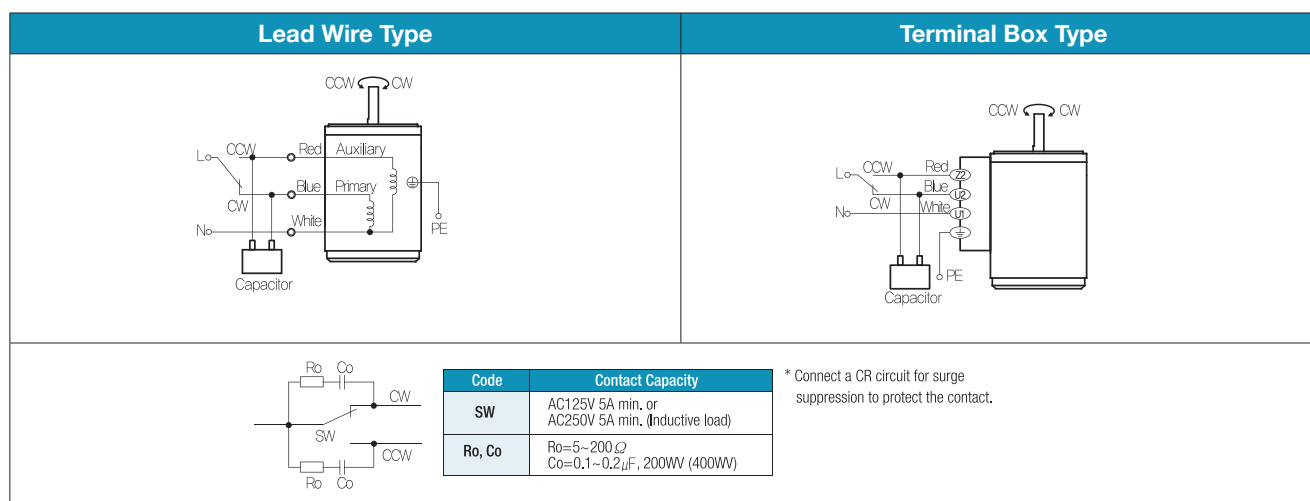

# A Information

## Product Coding System

### AC Motors

#### Motor

- I** : Induction Motor
- R** : Reversible Motor
- B** : Electromagnetic Brake Motor
- Cl** : Clutch & Brake Motor
- T** : Torque Motor
- S** : Speed Control Induction Motor
- SR** : Speed Control Reversible Motor
- SB** : Speed Control . Brake Motor
- CS** : Speed Control Clutch & Brake Motor

**9 I D G A**

#### Motor Frame Size

- 6** : □60mm sq. (2.36 inch sq.)
- 7** : □70mm sq. (2.76 inch sq.)
- 8** : □80mm sq. (3.15 inch sq.)
- 9** : □90mm sq. (3.54 inch sq.)
- 10** : □104mm sq. (4.09 inch sq.)

**Brand**  
**D** : DKM

#### Output Shaft Type

- G** : Gear Type Shaft  
(Pinion Shaft for Attaching Gearbox)
- S** : Round Type Shaft ○
- D** : D-Cut Type Shaft □
- K** : Key Type Shaft ⊕

#### Phase & Voltage

- 1** : 1Ø AC 110V 60Hz
- 2** : 1Ø AC 220V 60Hz
- 3** : 3Ø AC 220~230V 50/60Hz
- 4** : 3Ø AC 380V~400V 50/60Hz
- 5** : 3Ø AC 415V~440V 50/60Hz
- 6** : 3Ø AC 220/380V 60Hz
- 7** : 3Ø AC 230/400V 50Hz
- 8** : 3Ø AC 440V 50/60Hz

#### Phase & Voltage

[Built-in Thermal Protector Type]

- A** : 1Ø AC 110V 60Hz
- D** : 1Ø AC 220V 60Hz
- E** : 1Ø AC 220~240V 50Hz
- G** : 3Ø AC 220V 50/60Hz
- K** : 3Ø AC 380V~400V 50/60Hz
- L** : 3Ø AC 415V~440V 50/60Hz

#### Fan Type

- F** : General Fan (Self Cooling)
- F2** : Powerful Fan (Separate Fan Motor)  
Powerful fan makes powerful cooling performance rotating in high speed regardless of motor shaft speed.
- No Mark** : Without Fan

#### Connection Type

- T** : Terminal Box Type
- No Mark** : Lead Wire Type

#### Pole

- A** : 2 Pole
- No Mark** : 4 Pole

**90 F P - A T**

#### Output

- 6** : 6W
- 10** : 10W
- 15** : 15W
- 25** : 25W
- 40** : 40W
- 60** : 60W
- 90** : 90W
- 120** : 120W
- 150** : 150W
- 180** : 180W
- 200** : 200W
- 250** : 250W (E)
- 300** : 300W (D, 7, 8)
- 400** : 400W (6)

#### Attaching Gearbox

- G** : General Box Type
- P** : Powerful Box/Flange Type
- H** : High Powerful Box/Flange Type
- W** : Worm Solid Type
- WH** : Worm Hollow Type
- No Mark** : Without Gearbox

### DC Motors

**DC**  
DC MOTOR

#### Output Shaft Type

- D** : D-Cut Type Shaft
- K** : Key Type Shaft
- G** : Shaft for General Type Gearbox
- P** : Shaft for Powerful Type Gearbox
- W** : Shaft for Worm Solid Type Gearbox

**9 DC G 12 - 25 - 30**

#### Motor Frame Size

- 6** : □60mm sq. (2.36 in.sq.)
- 8** : □80mm sq. (3.15 in.sq.)
- 9** : □90mm sq. (3.54 in.sq.)

#### DC Voltage

- 12** : DC 12V
- 24** : DC 24V
- 90** : DC 90V

#### Output

- 15** : 15W
- 25** : 25W
- 40** : 40W
- 60** : 60W
- 90** : 90W
- 120** : 120W

#### r/min

- 30** : 3000r/min



## Parallel Gearbox

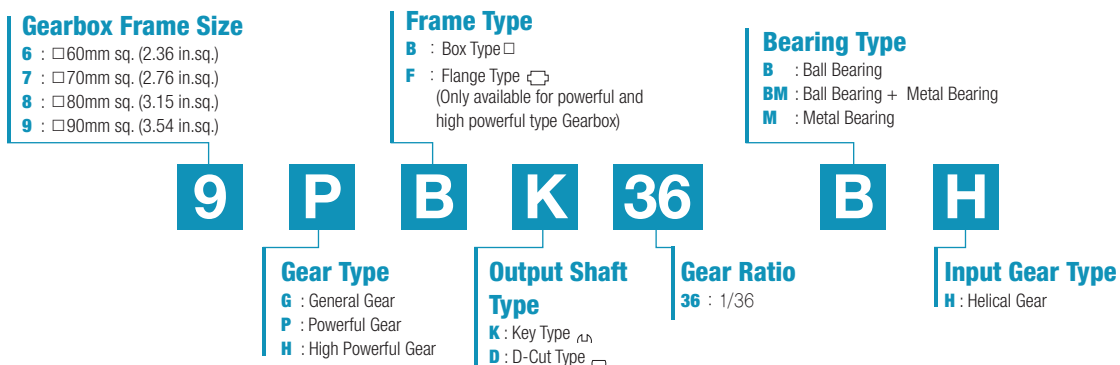

## Worm Solid Gearbox

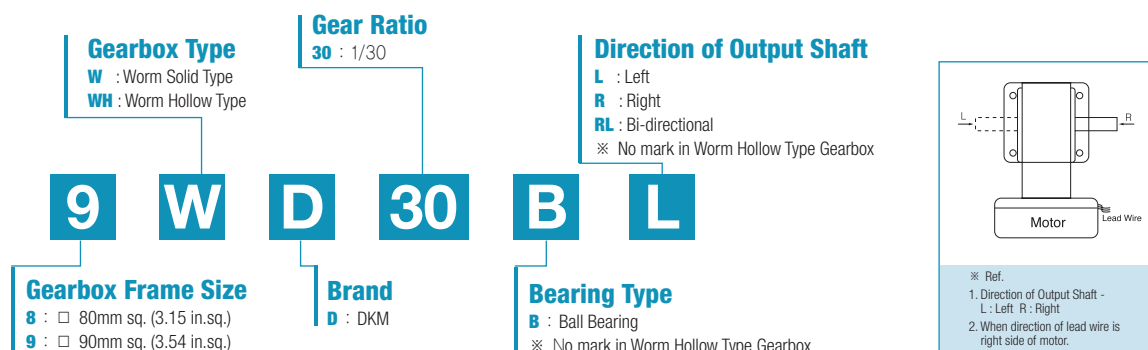

## Worm Hollow Gearbox

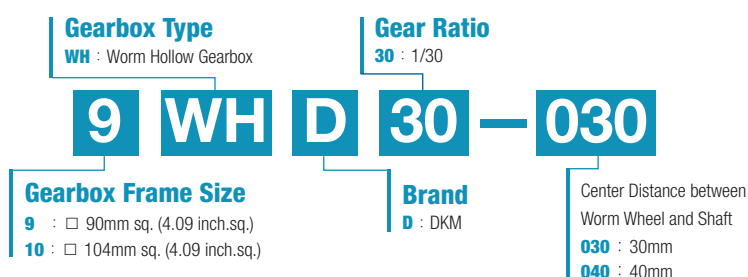

## Inter-decimal Gearbox



In case of requiring high gear reduction ratio that cannot be generated by single Gearbox, please use Inter-decimal Gearbox with general Gearbox. And please be advised that in this case only revolution speed of output shaft will reduce by 10:1 without increasing of maximum permissible torque.

# A Information

## Product Coding System

### Assembly of Motor and Gearbox

#### Motor + Gearbox

- As shown in the following scheme, motor and Gearbox which have same frame size and gear type could be assembled.

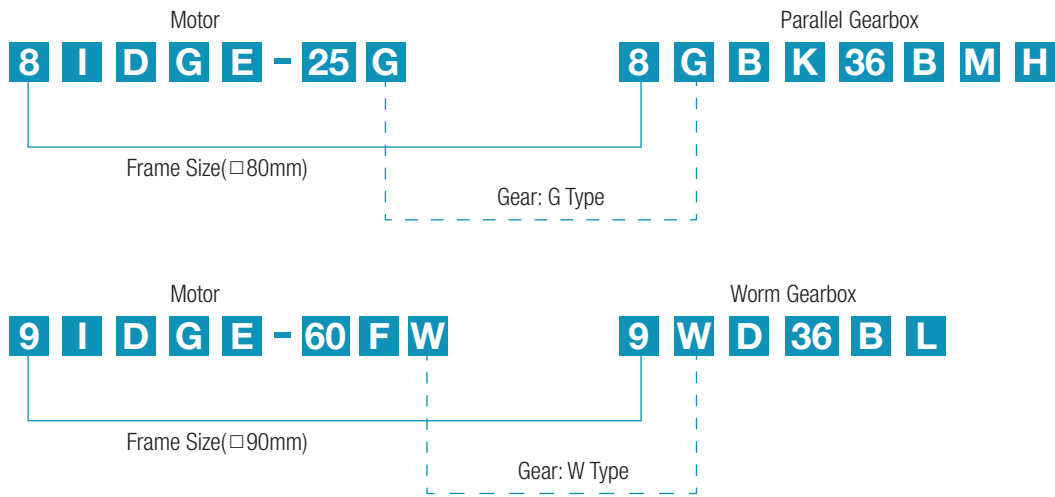

#### Motor + Inter-decimal Gearbox + Gearbox

- When using an inter-decimal Gearbox together, give attention to the gear types of motor, Gearbox and inter-decimal Gearbox.

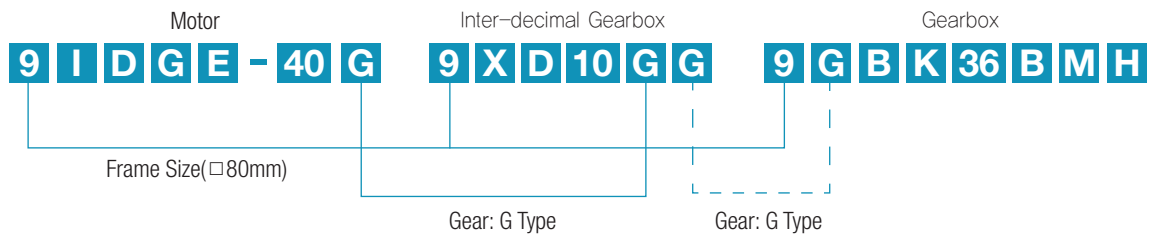

- When attaching inter-decimal Gearbox, the output shaft type of the motor is always G type. For example, when using P/H/W/WH type Gearbox, only the gear type of inter-decimal Gearbox is identical with attached Gearbox and the output shaft type of the motor is G type. (Refer to the scheme below.)

# B AC Motors

## Reversible Motor 6W(□ 60mm)

# 6W

Reversible Motor  
6W(□ 60mm)

### Motor Specification

Model		Output	Voltage	Frequency	Poles	Duty	Starting Torque		Rated Load				Capacitor
Lead Wire Type	Terminal Box Type						kgfcm	N.m	Speed	Current	Torque		
6RDG□-6G(-T): Gear Type Shaft 6RDD□-6(-T): D-Cut Type Shaft		W	V	Hz					r/min	A	kgfcm	N.m	
6RDGA-6G	6RDGA-6G-T	6	1∅110	60	4	30min.	0.60	0.060	1550	0.25	0.38	0.038	3.0 / 250
6RDGD-6G	6RDGD-6G-T	6	1∅220	60	4	30min.	0.62	0.062	1550	0.15	0.42	0.042	1.0 / 450
6RDGE-6G	6RDGE-6G-T	6	1∅220	50	4	30min.	0.50	0.050	1200	0.10	0.47	0.047	0.7 / 450
			1∅240				0.55	0.055					

- 1) Enter the phase & voltage code in the box (□) within the motor model name.
- 2) This model is impedance protected type.
- 3) Gear Type Shaft is for attaching Gearbox and D-Cut Type Shaft is for using motor only.

### Max. Permissible Torque at Output Shaft of Gearbox

#### 60Hz

Motor Model	Gearbox Model	Gear Ratio	3	3.6	5	6	7.5	9	10	12.5	15	18	20	25	30	36	40	50	60	75	90	100	120	150	180
			r/min	600	500	360	300	240	200	180	144	120	100	90	72	60	50	45	36	30	24	20	18	15	12
6RDG□-6G	6GBD□MH	kgfcm	1.0	1.3	1.7	2.1	2.6	3.1	3.5	4.4	5.2	6.3	6.3	7.9	9.5	11.3	12.6	14.3	17.1	21.4	25.7	28.6	30.0	30.0	30.0
		N.m	0.10	0.12	0.17	0.20	0.26	0.31	0.34	0.43	0.51	0.61	0.62	0.77	0.93	1.11	1.23	1.40	1.68	2.10	2.52	2.80	2.94	2.94	2.94

Motor Model	Gearbox Model	Gear Ratio	200	250
			r/min	9
6RDG□-6G	6GBD□MH	kgfcm	30.0	30.0
		N.m	2.94	2.94

#### 50Hz

Motor Model	Gearbox Model	Gear Ratio	3	3.6	5	6	7.5	9	10	12.5	15	18	20	25	30	36	40	50	60	75	90	100	120	150	180
			r/min	500	417	300	250	200	166	150	120	100	83	75	60	50	41	37	30	25	20	16	15	12	10
6RDG□-6G	6GBD□MH	kgfcm	1.2	1.5	2.1	2.5	3.1	3.7	4.2	5.2	6.2	7.5	7.5	9.4	11.3	13.5	15.0	17.0	20.4	25.5	30.0	30.0	30.0	30.0	30.0
		N.m	0.12	0.15	0.20	0.24	0.31	0.37	0.41	0.51	0.61	0.73	0.74	0.92	1.10	1.32	1.47	1.67	2.00	2.50	2.94	2.94	2.94	2.94	2.94

Motor Model	Gearbox Model	Gear Ratio	200	250
			r/min	7.5
6RDG□-6G	6GBD□MH	kgfcm	30.0	30.0
		N.m	2.94	2.94

- 1) Enter the phase & voltage code in the box (□) within the motor model name.
- 2) Enter the gear ratio in the box (□) within the Gearbox model name.
- 3) A colored background indicates gear shaft rotation in the same direction as the motor shaft; a white background indicates rotation in the opposite direction.
- 4) The rotating speed is calculated by dividing the motor's synchronous speed (50Hz: 1,500r/min, 60Hz: 1,800r/min) by the gear ratio. The actual speed is 2~20% less than the displayed value, depending on the size of the load.

### Motor Images



## Dimensions

### MOTOR ONLY

- MOTOR MODEL: 6RDD□-6(-T) (NO FAN)

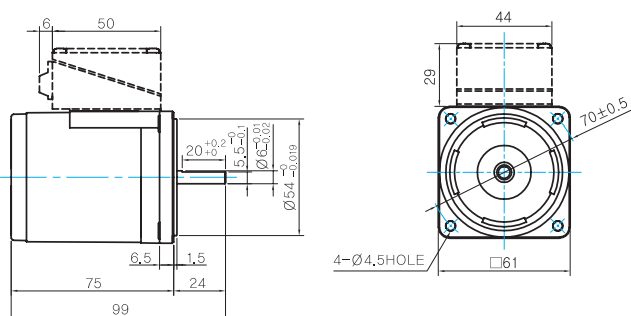

### MOTOR OUTPUT SHAFT

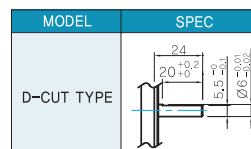

### GEARED MOTOR

### G TYPE GEARBOX

- MOTOR MODEL: 6RDG□-6G (NO FAN)
- GEARBOX MODEL: 6GBD□MH

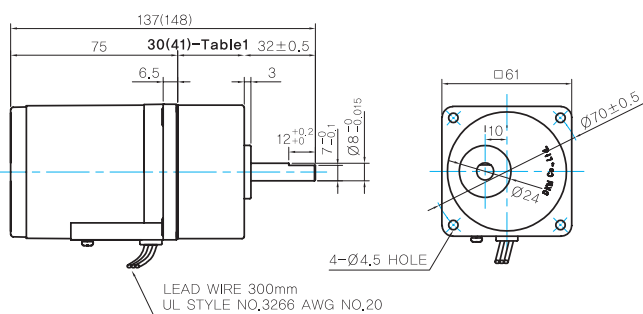

### GEARBOX OUTPUT SHAFT

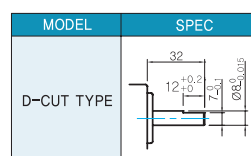

### WEIGHT

PART	WEIGHT(Kg)	
MOTOR	0,7	
GEAR BOX	6GBD3MH ~ 6GBD18MH	0,3
	6GBD20MH ~ 6GBD40MH	0,32
	6GBD50MH ~ 6GBD250MH	0,34

### 30(41)-Table1

SIZE(mm)	GEAR RATIO
30	6GBD3MH - 6GBD18MH
41	6GBD20MH - 6GBD250MH

## Connection Diagrams

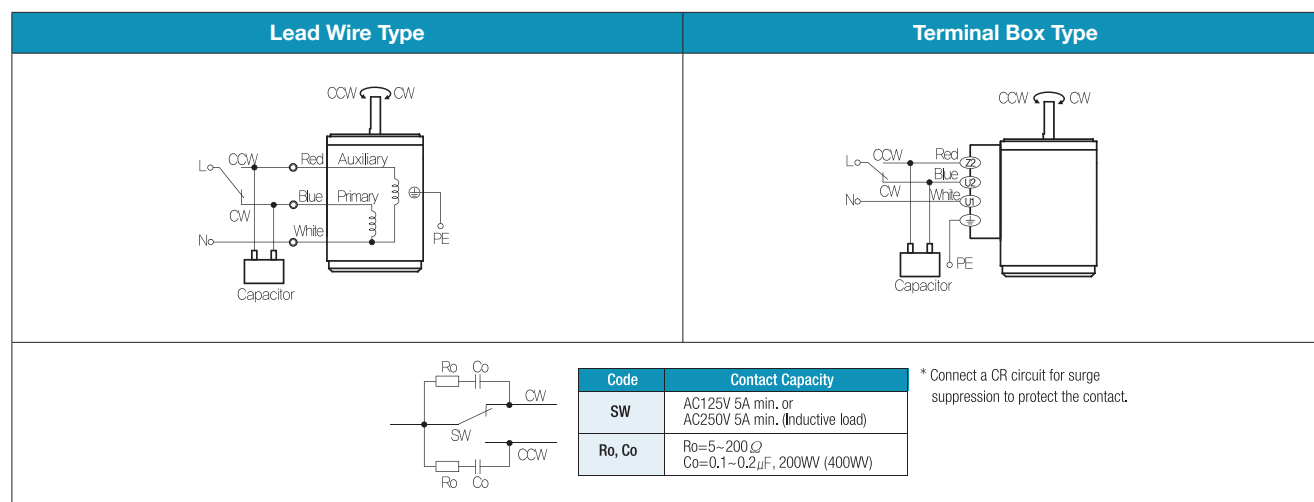

- The direction of motor rotation is as viewed from the shaft end of the motor.
- CW represents the clockwise direction, while CCW represents the counterclockwise direction.
- During operation it is available to change the rotating direction by turning the switch to CW or CCW.

# B AC Motors

## Reversible Motor 6W(□ 70mm)

# 6W Reversible Motor 6W(□ 70mm)

### Motor Specification

Model		Output	Voltage	Frequency	Poles	Duty	Starting Torque		Rated Load				Capacitor
Lead Wire Type	Terminal Box Type						kgfcm	N.m	Speed	Current	Torque		
7RDG□-6G(-T): Gear Type Shaft 7RDD□-6(-T): D-Cut Type Shaft		W	V	Hz					r/min	A	kgfcm	N.m	
7RDGA-6G	7RDGA-6G-T	6	1∅110	60	4	30min.	0.64	0.064	1600	0.29	0.50	0.050	3.0 / 250
7RDGD-6G	7RDGD-6G-T	6	1∅220	60	4	30min.	0.85	0.085	1600	0.16	0.60	0.060	1.0 / 450
7RDGE-6G	7RDGE-6G-T	6	1∅220	50	4	30min.	0.61	0.061	1250	0.13	0.68	0.068	0.8 / 450
			1∅240				0.75	0.075					

- 1) Enter the phase & voltage code in the box (□) within the motor model name.
- 2) All models contain a built-in thermal protector.
- 3) Gear Type Shaft is for attaching Gearbox and D-Cut Type Shaft is for using motor only.

### Max. Permissible Torque at Output Shaft of Gearbox

#### 60Hz

Motor Model	Gearbox Model	Gear Ratio	3	3.6	6	7.5	9	12.5	15	18	25	30	36	50	60	75	90	100	120	150	180
			r/min	600	500	300	240	200	144	120	100	72	60	50	36	30	24	20	18	15	12
7RDG□-6G	7GBK□BMH	kgfcm	1.5	1.8	3.0	3.7	4.5	6.2	7.5	9.0	11.3	13.5	14.7	20.4	24.5	30.6	36.7	40.8	49.0	50.0	50.0
		N.m	0.15	0.18	0.29	0.37	0.44	0.61	0.73	0.88	1.10	1.32	1.44	2.00	2.40	3.00	3.60	4.00	4.80	4.90	4.90

#### 50Hz

Motor Model	Gearbox Model	Gear Ratio	3	3.6	6	7.5	9	12.5	15	18	25	30	36	50	60	75	90	100	120	150	180
			r/min	500	416	250	200	166	120	100	83	60	50	41	30	25	20	16	15	12.5	10
7RDG□-6G	7GBK□BMH	kgfcm	1.7	2.0	3.4	4.2	5.1	7.1	8.5	10.2	12.8	15.3	16.6	23.1	27.7	34.7	41.6	46.2	50.0	50.0	50.0
		N.m	0.17	0.20	0.33	0.41	0.50	0.69	0.83	1.00	1.25	1.50	1.63	2.27	2.72	3.40	4.08	4.53	4.90	4.90	4.90

- 1) Enter the phase & voltage code in the box (□) within the motor model name.
- 2) Enter the gear ratio in the box (□) within the Gearbox model name.
- 3) A colored background indicates gear shaft rotation in the same direction as the motor shaft; a white background indicates rotation in the opposite direction.
- 4) The rotating speed is calculated by dividing the motor's synchronous speed (50Hz: 1,500r/min, 60Hz: 1,800r/min) by the gear ratio. The actual speed is 2~20% less than the displayed value, depending on the size of the load.

### Motor Images



## Dimensions

### MOTOR ONLY

MOTOR MODEL: 7RDD□-6(-T) (NO FAN)

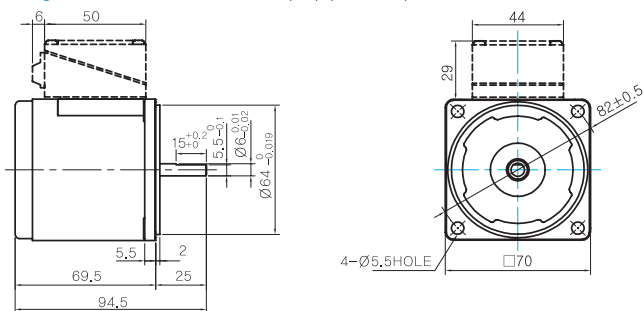

### MOTOR OUTPUT SHAFT

MODEL	SPEC
D-CUT TYPE	

### GEARED MOTOR

#### G TYPE GEARBOX

MOTOR MODEL: 7RDG□-6G (NO FAN)

GEARBOX MODEL: 7GBK□BMH

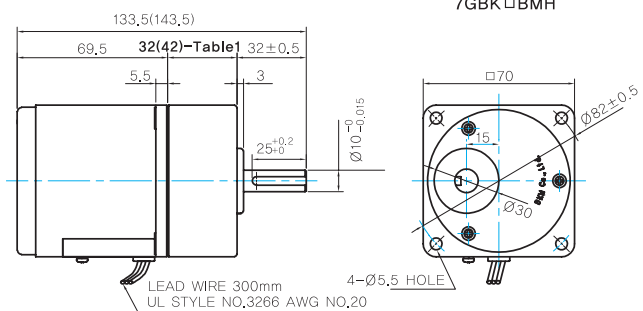

#### GEARBOX OUTPUT SHAFT

MODEL	SPEC
KEY TYPE	

#### KEY SPEC

GEARBOX	

#### WEIGHT

PART	WEIGHT(Kg)
MOTOR	0,84
7GBK3BMH ~ 7GBK18BMH	0,36
7GBK25BMH ~ 7GBK30BMH	0,44
7GBK36MH ~ 7GBK180MH	0,5

#### 32(42)-Table1

SIZE(mm)	GEAR RATIO
32	7GBK3BMH - 7GBK18BMH
42	7GBK25BMH - 7GBK180BMH

## Connection Diagrams

Lead Wire Type	Terminal Box Type						
	<table border="1"> <thead> <tr> <th>Code</th> <th>Contact Capacity</th> </tr> </thead> <tbody> <tr> <td>SW</td> <td>AC125V 5A min. or AC250V 5A min. (Inductive load)</td> </tr> <tr> <td>R0, Co</td> <td>R0=5-200Ω Co=0.1-0.2μF, 200WV (400WV)</td> </tr> </tbody> </table> <p>* Connect a CR circuit for surge suppression to protect the contact.</p>	Code	Contact Capacity	SW	AC125V 5A min. or AC250V 5A min. (Inductive load)	R0, Co	R0=5-200Ω Co=0.1-0.2μF, 200WV (400WV)
Code	Contact Capacity						
SW	AC125V 5A min. or AC250V 5A min. (Inductive load)						
R0, Co	R0=5-200Ω Co=0.1-0.2μF, 200WV (400WV)						

- 1) The direction of motor rotation is as viewed from the shaft end of the motor.
- 2) CW represents the clockwise direction, while CCW represents the counterclockwise direction.
- 3) During operation it is available to change the rotating direction by turning the switch to CW or CCW.

# B AC Motors

## Reversible Motor 10W(□70mm)

# 10W

Reversible Motor  
10W(□70mm)

### Motor Specification

Model		Output	Voltage	Frequency	Poles	Duty	Starting Torque		Rated Load				Capacitor
Lead Wire Type	Terminal Box Type						kgfcm	N.m	Speed	Current	Torque		
7RDG□-10G(-T): Gear Type Shaft 7RDD□-10(-T): D-Cut Type Shaft		W	V	Hz					r/min	A	kgfcm	N.m	
7RDGA-10G	7RDGA-10G-T	10	1∅110	60	4	30min.	0.83	0.083	1550	0.31	0.70	0.070	3.5 / 250
7RDGD-10G	7RDGD-10G-T	10	1∅220	60	4	30min.	1.00	0.100	1550	0.20	0.79	0.079	1.2 / 450
7RDGE-10G	7RDGE-10G-T	10	1∅220	50	4	30min.	0.86	0.086	1250	0.16	0.82	0.082	1.0 / 450
			1∅240				0.99	0.099		0.18	0.90	0.090	

- 1) Enter the phase & voltage code in the box (□) within the motor model name.
- 2) All models contain a built-in thermal protector.
- 3) Gear Type Shaft is for attaching Gearbox and D-Cut Type Shaft is for using motor only.

### Max. Permissible Torque at Output Shaft of Gearbox

#### 60Hz

Motor Model	Gearbox Model	Gear Ratio	3	3.6	6	7.5	9	12.5	15	18	25	30	36	50	60	75	90	100	120	150	180
			r/min	600	500	300	240	200	144	120	100	72	60	50	36	30	24	20	18	15	12
7RDG□-10G	7GBK□BMH	kgfcm	2.0	2.4	3.9	4.9	5.9	8.2	9.8	11.8	14.8	17.8	19.3	26.9	32.2	40.3	48.3	50.0	50.0	50.0	50.0
		N.m	0.19	0.23	0.39	0.48	0.58	0.80	0.96	1.16	1.45	1.74	1.90	2.63	3.16	3.95	4.74	4.90	4.90	4.90	4.90

#### 50Hz

Motor Model	Gearbox Model	Gear Ratio	3	3.6	6	7.5	9	12.5	15	18	25	30	36	50	60	75	90	100	120	150	180
			r/min	500	416	250	200	166	120	100	83	60	50	41	30	25	20	16	15	12.5	10
7RDG□-10G	7GBK□BMH	kgfcm	2.2	2.7	4.5	5.6	6.7	9.3	11.2	13.4	16.9	20.3	22.0	30.6	36.7	45.9	50.0	50.0	50.0	50.0	50.0
		N.m	0.22	0.26	0.44	0.55	0.66	0.92	1.10	1.32	1.65	1.98	2.16	3.00	3.60	4.50	4.90	4.90	4.90	4.90	4.90

- 1) Enter the phase & voltage code in the box (□) within the motor model name.
- 2) Enter the gear ratio in the box (□) within the Gearbox model name.
- 3) A colored background indicates gear shaft rotation in the same direction as the motor shaft; a white background indicates rotation in the opposite direction.
- 4) The rotating speed is calculated by dividing the motor's synchronous speed (50Hz: 1,500r/min, 60Hz: 1,800r/min) by the gear ratio. The actual speed is 2~20% less than the displayed value, depending on the size of the load.

### Motor Images



## Dimensions

### MOTOR ONLY

- MOTOR MODEL: 7RDD□-10(-T) (NO FAN)

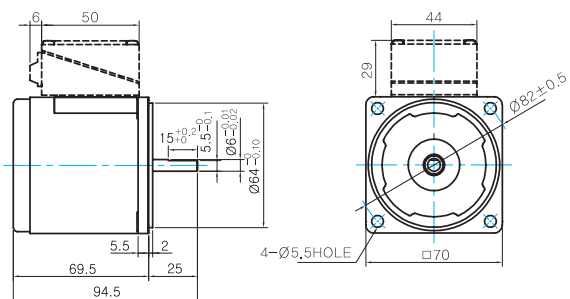

### MOTOR OUTPUT SHAFT

MODEL	SPEC
D-CUT TYPE	

### GEARED MOTOR

#### G TYPE GEARBOX

- MOTOR MODEL: 7RDG□-10G (NO FAN)
- GEARBOX MODEL: 7GBK□BMH

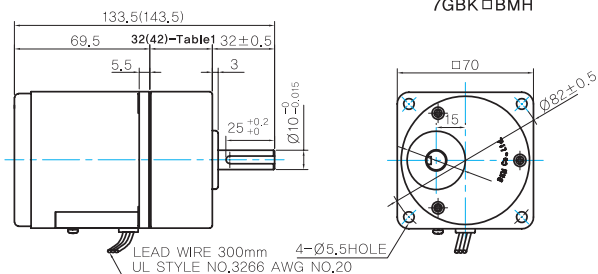

### GEARBOX OUTPUT SHAFT

MODEL	SPEC
KEY TYPE	

### KEY SPEC

GEARBOX	

### WEIGHT

PART	WEIGHT(Kg)	
MOTOR	0.84	
GEAR BOX	7GBK3BMH ~ 7GBK18BMH	0.36
	7GBK25BMH ~ 7GBK30BMH	0.44
	7GBK36MH ~ 7GBK180MH	0.5

### 32(42)-Table1

SIZE(mm)	GEAR RATIO
32	7GBK3BMH - 7GBK18BMH
42	7GBK25BMH - 7GBK180BMH

## Connection Diagrams

Lead Wire Type	Terminal Box Type						
	<table border="1"> <thead> <tr> <th>Code</th> <th>Contact Capacity</th> </tr> </thead> <tbody> <tr> <td>SW</td> <td>AC125V 5A min. or AC250V 5A min. (Inductive load)</td> </tr> <tr> <td>R<sub>0</sub>, Co</td> <td>R<sub>0</sub>=5-200Ω Co=0.1-0.2μF, 200WV (400WV)</td> </tr> </tbody> </table> <p>* Connect a CR circuit for surge suppression to protect the contact.</p>	Code	Contact Capacity	SW	AC125V 5A min. or AC250V 5A min. (Inductive load)	R <sub>0</sub> , Co	R <sub>0</sub> =5-200Ω Co=0.1-0.2μF, 200WV (400WV)
Code	Contact Capacity						
SW	AC125V 5A min. or AC250V 5A min. (Inductive load)						
R <sub>0</sub> , Co	R <sub>0</sub> =5-200Ω Co=0.1-0.2μF, 200WV (400WV)						

- The direction of motor rotation is as viewed from the shaft end of the motor.
- CW represents the clockwise direction, while CCW represents the counterclockwise direction.
- During operation it is available to change the rotating direction by turning the switch to CW or CCW.



# B AC Motors

Reversible Motor 15W(□70mm)

## 15W Reversible Motor 15W(□70mm)

### Motor Specification

Model		Output	Voltage	Frequency	Poles	Duty	Starting Torque		Rated Load			Capacitor	
Lead Wire Type	Terminal Box Type						kgfcm	N.m	Speed	Current	Torque		
7RDG□-15G(-T): Gear Type Shaft 7RDD□-15(-T): D-Cut Type Shaft		W	V	Hz				r/min	A	kgfcm	N.m	μF / VAC	
7RDGA-15G	7RDGA-15G-T	15	1∅110	60	4	30min.	1.30	0.130	1600	0.46	1.05	0.105	6.0 / 250
7RDGD-15G	7RDGD-15G-T	15	1∅220	60	4	30min.	1.25	0.125	1600	0.23	1.10	0.110	1.5 / 450
7RDGE-15G	7RDGE-15G-T	15	1∅220	50	4	30min.	1.10	0.110	1250	0.17	1.25	0.125	1.2 / 450
			1∅240				1.30	0.130		0.18	1.45	0.145	

- 1) Enter the phase & voltage code in the box (□) within the motor model name.
- 2) All models contain a built-in thermal protector.
- 3) Gear Type Shaft is for attaching Gearbox and D-Cut Type Shaft is for using motor only.

### Max. Permissible Torque at Output Shaft of Gearbox

#### 60Hz

Motor Model	Gearbox Model	Gear Ratio	3	3.6	6	7.5	9	12.5	15	18	25	30	36	50	60	75	90	100	120	150	180
			r/min	600	500	300	240	200	144	120	100	72	60	50	36	30	24	20	18	15	12
7RDG□-15G	7GBK□BMH	kgfcm	2.7	3.3	5.5	6.8	8.2	11.4	13.7	16.4	20.6	24.8	26.9	37.4	44.9	50.0	50.0	50.0	50.0	50.0	50.0
		N.m	0.27	0.32	0.54	0.67	0.81	1.12	1.34	1.61	2.02	2.43	2.64	3.67	4.40	4.90	4.90	4.90	4.90	4.90	4.90

#### 50Hz

Motor Model	Gearbox Model	Gear Ratio	3	3.6	6	7.5	9	12.5	15	18	25	30	36	50	60	75	90	100	120	150	180
			r/min	500	416	250	200	166	120	100	83	60	50	41	30	25	20	16	15	12.5	10
7RDG□-15G	7GBK□BMH	kgfcm	3.1	3.7	6.2	7.8	9.3	13.0	15.6	18.7	23.4	28.1	30.6	42.5	50.0	50.0	50.0	50.0	50.0	50.0	50.0
		N.m	0.31	0.37	0.61	0.76	0.92	1.27	1.53	1.83	2.30	2.76	3.00	4.17	4.90	4.90	4.90	4.90	4.90	4.90	4.90

- 1) Enter the phase & voltage code in the box (□) within the motor model name.
- 2) Enter the gear ratio in the box (□) within the Gearbox model name.
- 3) A colored background indicates gear shaft rotation in the same direction as the motor shaft; a white background indicates rotation in the opposite direction.
- 4) The rotating speed is calculated by dividing the motor's synchronous speed (50Hz: 1,500r/min, 60Hz: 1,800r/min) by the gear ratio. The actual speed is 2~20% less than the displayed value, depending on the size of the load.

### Motor Images



## Dimensions

### MOTOR ONLY

- MOTOR MODEL: 7RDD□-15(-T) (NO FAN)

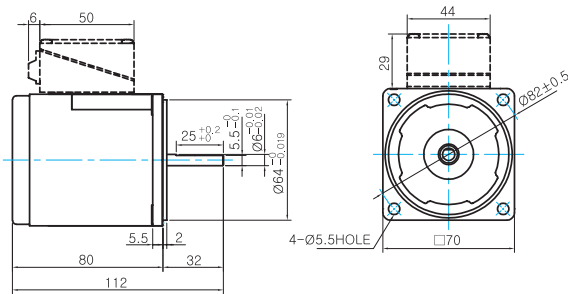

### MOTOR OUTPUT SHAFT

MODEL	SPEC
D-CUT TYPE	

### GEARED MOTOR

### G TYPE GEARBOX

- MOTOR MODEL: 7RDG□-15G (NO FAN)
- GEARBOX MODEL: 7GBK□BMH

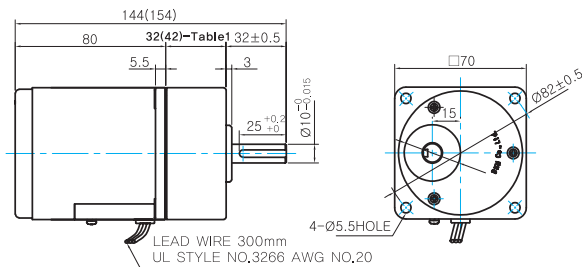

### GEARBOX OUTPUT SHAFT

MODEL	SPEC
KEY TYPE	

### KEY SPEC

GEARBOX	

### WEIGHT

PART	WEIGHT(Kg)
MOTOR	1.04
GEAR BOX	
7GBK3BMH ~ 7GBK18BMH	0.36
7GBK25BMH ~ 7GBK30BMH	0.44
7GBK36MH ~ 7GBK180MH	0.5

### 32(42)-Table1

SIZE(mm)	GEAR RATIO
32	7GBK3BMH - 7GBK18BMH
42	7GBK25BMH - 7GBK180BMH

## Connection Diagrams

Lead Wire Type	Terminal Box Type						
	<table border="1" style="width: 100%;"> <thead> <tr> <th>Code</th> <th>Contact Capacity</th> </tr> </thead> <tbody> <tr> <td>SW</td> <td>AC125V 5A min. or AC250V 5A min. (Inductive load)</td> </tr> <tr> <td>Ro, Co</td> <td>Ro=5~200Ω Co=0.1~0.2μF, 200WV (400WV)</td> </tr> </tbody> </table> <p>* Connect a CR circuit for surge suppression to protect the contact.</p>	Code	Contact Capacity	SW	AC125V 5A min. or AC250V 5A min. (Inductive load)	Ro, Co	Ro=5~200Ω Co=0.1~0.2μF, 200WV (400WV)
Code	Contact Capacity						
SW	AC125V 5A min. or AC250V 5A min. (Inductive load)						
Ro, Co	Ro=5~200Ω Co=0.1~0.2μF, 200WV (400WV)						

- The direction of motor rotation is as viewed from the shaft end of the motor.
- CW represents the clockwise direction, while CCW represents the counterclockwise direction.
- During operation it is available to change the rotating direction by turning the switch to CW or CCW.

# B AC Motors

## Reversible Motor 15W(□80mm)

# 15W

Reversible Motor  
15W(□80mm)

### Motor Specification

Model		Output	Voltage	Frequency	Poles	Duty	Starting Torque		Rated Load				Capacitor
Lead Wire Type	Terminal Box Type						kgfcm	N.m	Speed	Current	Torque		
8RDG*-15□(-T): Gear Type Shaft 8RDD*-15(-T): D-Cut Type Shaft		W	V	Hz					r/min	A	kgfcm	N.m	
8RDGA-15□	8RDGA-15□-T	15	1∅110	60	4	30min.	1.55	0.155	1600	0.44	1.20	0.120	6.0 / 250
8RDGD-15□	8RDGD-15□-T	15	1∅220	60	4	30min.	1.50	0.150	1600	0.25	1.00	0.100	1.5 / 450
8RDGE-15□	8RDGE-15□-T	15	1∅220	50	4	30min.	1.25	0.125	1200	0.16	1.30	0.130	1.5 / 450
			1∅240				1.45	0.145					

1) Enter the phase & voltage code in the place \* and enter the model type of attaching Gearbox in the box (□) within the motor model name.

2) All models contain a built-in thermal protector.

3) Gear Type Shaft is for attaching Gearbox and D-Cut Type Shaft is for using motor only.

### Max. Permissible Torque at Output Shaft of Gearbox

#### 60Hz

Motor Model	Gearbox Model	Gear Ratio	3	3.6	5	6	7.5	9	12.5	15	18	25	30	36	40	50	60	75	90	100	120	150	180	
			r/min	600	500	360	300	240	200	144	120	100	72	60	50	45	36	30	24	20	18	15	12	10
8RDG□-15G	8GBK□BMH	kgfcm	3.0	3.6	5.0	6.0	7.5	9.0	12.5	14.9	17.9	22.5	27.0	29.4	32.6	40.8	49.0	61.2	73.4	80.0	80.0	80.0	80.0	80.0
		N.m	0.29	0.35	0.49	0.59	0.73	0.88	1.22	1.46	1.76	2.21	2.65	2.88	3.20	4.00	4.80	6.00	7.20	7.84	7.84	7.84	7.84	7.84

Motor Model	Gearbox Model	Gear Ratio	200	250	300	360
			r/min	9	7	6
8RDG□-15G	8GBK□BMH	kgfcm	80.0	80.0	80.0	80.0
		N.m	7.84	7.84	7.84	7.84

Motor Model	Gearbox Model	Gear Ratio	10	12	15	18	25	30	36	50	60
			r/min	180	150	120	100	72	60	50	36
8RDG□-15W	8WD□BL/□BR/□BRL	kgfcm	9.8	11.5	13.9	16.0	21.0	23.8	27.6	36.0	39.6
		N.m	0.96	1.13	1.36	1.57	2.06	2.33	2.71	3.53	3.88

#### 50Hz

Motor Model	Gearbox Model	Gear Ratio	3	3.6	5	6	7.5	9	12.5	15	18	25	30	36	40	50	60	75	90	100	120	150	180
			r/min	500	417	300	250	200	167	120	100	83	60	50	42	38	30	25	20	17	15	13	10
8RDG□-15G	8GBK□BMH	kgfcm	3.5	4.2	5.8	7.0	8.7	10.5	14.5	17.4	20.9	26.3	31.5	34.3	38.1	47.6	57.1	71.4	80.0	80.0	80.0	80.0	80.0
		N.m	0.34	0.41	0.57	0.68	0.85	1.02	1.42	1.71	2.05	2.57	3.09	3.36	3.73	4.66	5.60	7.00	7.84	7.84	7.84	7.84	7.84

Motor Model	Gearbox Model	Gear Ratio	200	250	300	360
			r/min	7	6	5
8RDG□-15G	8GBK□BMH	kgfcm	80.0	80.0	80.0	80.0
		N.m	7.84	7.84	7.84	7.84

Motor Model	Gearbox Model	Gear Ratio	10	12	15	18	25	30	36	50	60
			r/min	150	125	100	83	60	50	42	30
8RDG□-15W	8WD□BL/□BR/□BRL	kgfcm	11.5	13.4	16.2	18.6	24.5	27.7	32.3	42.0	46.2
		N.m	1.13	1.32	1.58	1.83	2.40	2.72	3.16	4.12	4.53

1) Enter the phase & voltage code in the box (□) within the motor model name.

2) Enter the gear ratio in the box (□) within the Gearbox model name.

3) A colored background indicates gear shaft rotation in the same direction as the motor shaft; a white background indicates rotation in the opposite direction.

4) The rotating speed is calculated by dividing the motor's synchronous speed (50Hz: 1,500r/min, 60Hz: 1,800r/min) by the gear ratio. The actual speed is 2~20% less than the displayed value, depending on the size of the load.

## Dimensions

### MOTOR ONLY

- MOTOR MODEL: 8RDD□-15(-T) (NO FAN)

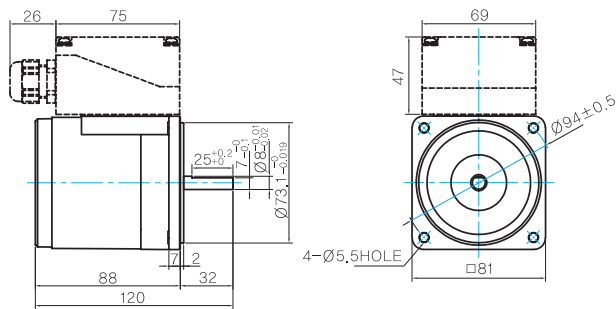

### MOTOR OUTPUT SHAFT

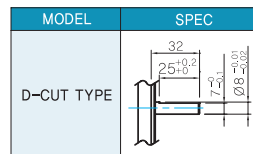

### INTER-DECIMAL GEARBOX

- MODEL: 8XD10□□

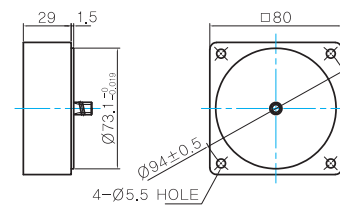

## GEARED MOTOR

### G TYPE GEARBOX

- MOTOR MODEL: 8RDD□-15G (NO FAN)
- GEARBOX MODEL: 8GBK□BMH

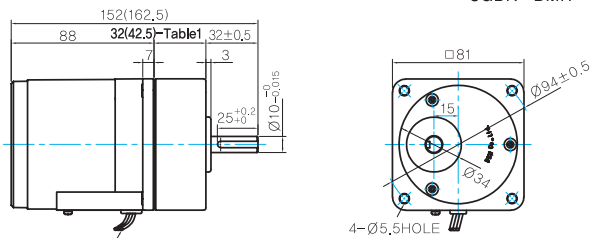

LEAD WIRE 300mm  
UL STYLE NO,3271 AWG NO,22

### GEARBOX OUTPUT SHAFT

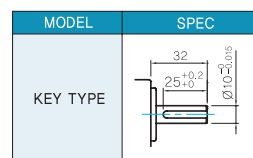

### KEY SPEC

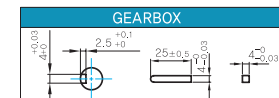

### 32(42.5)-Table1

SIZE(mm)	GEAR RATIO
32	8GBK3BMH - 8GBK18BMH
42,5	8GBK25BMH - 8GBK360BMH

### W TYPE GEARBOX

- MOTOR MODEL: 8RDG□-15W (NO FAN)
- GEARBOX MODEL: 8WD□BL/BR/BRL

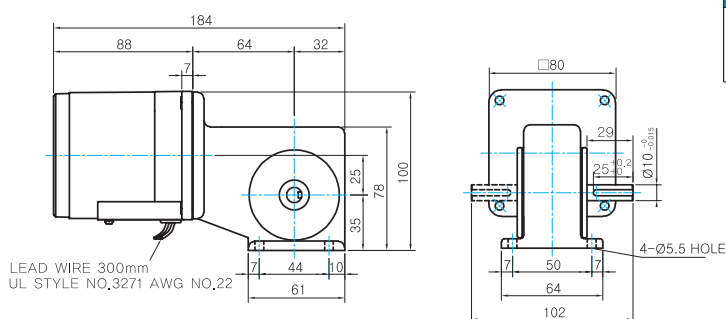

LEAD WIRE 300mm  
UL STYLE NO,3271 AWG NO,22

### KEY SPEC

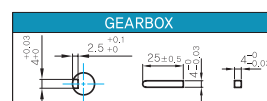

### WEIGHT

PART	WEIGHT(Kg)	
MOTOR	1,6	
GEAR BOX	8GBK3BMH ~ 8GBK18BMH	0,48
	8GBK25BMH ~ 8GBK30BMH	0,61
	8GBK36BMH ~ 8GBK180BMH	0,67
	8GBK200BMH ~ 8GBK360BMH	0,63
	8WD□BL/BR/BRL	0,67
8XD10□□	0,44	

## Motor Images

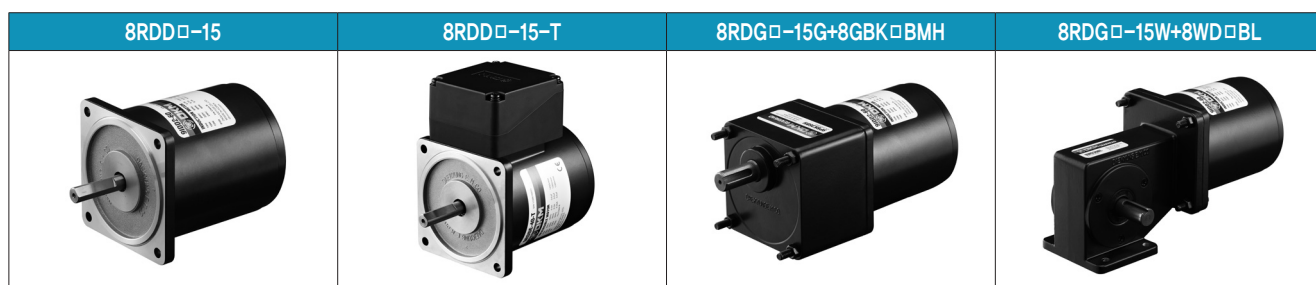

# B AC Motors

## Reversible Motor 15W(□80mm)

### Connection Diagrams

Lead Wire Type	Terminal Box Type						
	<table border="1" style="margin-left: auto; margin-right: auto;"> <thead> <tr> <th style="background-color: #0070C0; color: white;">Code</th> <th style="background-color: #0070C0; color: white;">Contact Capacity</th> </tr> </thead> <tbody> <tr> <td style="text-align: center;"><b>SW</b></td> <td>AC125V 5A min. or AC250V 5A min. (Inductive load)</td> </tr> <tr> <td style="text-align: center;"><b>Ro, Co</b></td> <td>Ro=5~200Ω Co=0.1~0.2μF, 200W (400W)</td> </tr> </tbody> </table> <p style="font-size: small; margin-top: 5px;">* Connect a CR circuit for surge suppression to protect the contact.</p>	Code	Contact Capacity	<b>SW</b>	AC125V 5A min. or AC250V 5A min. (Inductive load)	<b>Ro, Co</b>	Ro=5~200Ω Co=0.1~0.2μF, 200W (400W)
Code	Contact Capacity						
<b>SW</b>	AC125V 5A min. or AC250V 5A min. (Inductive load)						
<b>Ro, Co</b>	Ro=5~200Ω Co=0.1~0.2μF, 200W (400W)						

- 1) The direction of motor rotation is as viewed from the shaft end of the motor.
- 2) CW represents the clockwise direction, while CCW represents the counterclockwise direction.
- 3) During operation it is available to change the rotating direction by turning the switch to CW or CCW.

**Reversible Motor 25W(□80mm)**

**25W** Reversible Motor 25W(□80mm)

Reversible Motor 25W(□80mm)

**Motor Specification**

Model		Output W	Voltage V	Frequency Hz	Poles	Duty	Starting Torque		Rated Load			Capacitor μF / VAC	
Lead Wire Type	Terminal Box Type						kgfcm	N.m	Speed r/min	Current A	Torque kgfcm N.m		
8RDGA*–25□(-T): Gear Type Shaft	8RDGA–25□–T	25	1∅110	60	4	30min.	2.40	0.240	1550	0.73	1.62	0.162	10.0 / 250
8RDGD*–25(-T): D-Cut Type Shaft	8RDGD–25□–T	25	1∅220	60	4	30min.	2.40	0.240	1550	0.36	1.62	0.162	2.5 / 450
		25	1∅220	50	4	30min.	2.10	0.210	1250	0.28	2.00	0.200	2.0 / 450
			1∅240				2.50	0.250		0.30	2.10	0.210	

- 1) Enter the phase & voltage code in the place \* and enter the model type of attaching Gearbox in the box (□) within the motor model name.
- 2) All models contain a built-in thermal protector.
- 3) Gear Type Shaft is for attaching Gearbox and D-Cut Type Shaft is for using motor only.

**Max. Permissible Torque at Output Shaft of Gearbox**

**60Hz**

Motor Model	Gearbox Model	Gear Ratio	Gear Ratios																				
			3	3.6	5	6	7.5	9	12.5	15	18	25	30	36	40	50	60	75	90	100	120	150	180
8RDG□–25G	8GBK□ BMH	r/min	600	500	360	300	240	200	144	120	100	72	60	50	45	36	30	24	20	18	15	12	10
		kgfcm N.m	4.0 0.40	4.8 0.47	6.7 0.66	8.1 0.79	10.1 1.01	12.1 1.19	16.8 1.65	20.2 1.98	24.2 2.37	30.38 2.98	36.45 3.57	39.66 3.89	44.06 4.32	55.08 5.40	66.10 6.48	80.00 7.84	80.00 7.84	80.00 7.84	80.00 7.84	80.00 7.84	80.00 7.84

Motor Model	Gearbox Model	Gear Ratio	Gear Ratios				Motor Model	Gearbox Model	Gear Ratio	Gear Ratios								
			200	250	300	360				10	12	15	18	25	30	36	50	60
8RDG□–25G	8GBK□BMH	r/min	9	7	6	5	8RDG□–25W	8WD□BL/□BR/ □BRL	kgfcm N.m	13.3	15.6	18.7	21.6	28.4	32.1	37.3	48.6	53.5
		7.84	7.84	7.84	7.84	1.30				1.52	1.83	2.11	2.78	3.14	3.66	4.76	5.24	

**50Hz**

Motor Model	Gearbox Model	Gear Ratio	Gear Ratios																				
			3	3.6	5	6	7.5	9	12.5	15	18	25	30	36	40	50	60	75	90	100	120	150	180
8RDG□–25G	8GBK□ BMH	r/min	500	417	300	250	200	167	120	100	83	60	50	42	38	30	25	20	17	15	13	10	8
		kgfcm N.m	5.2 0.51	6.3 0.61	8.7 0.85	10.5 1.02	13.1 1.28	15.7 1.54	21.8 2.14	26.1 2.56	31.4 3.07	39.4 3.86	47.3 4.63	51.4 5.04	57.1 5.60	71.4 7.00	80.0 7.84	80.0 7.84	80.0 7.84	80.0 7.84	80.0 7.84	80.0 7.84	80.0 7.84

Motor Model	Gearbox Model	Gear Ratio	Gear Ratios				Motor Model	Gearbox Model	Gear Ratio	Gear Ratios								
			200	250	300	360				10	12	15	18	25	30	36	50	60
8RDG□–25G	8GBK□BMH	r/min	7	6	5	5	8RDG□–25W	8WD□BL/□BR/ □BRL	kgfcm N.m	17.2	20.2	24.3	28.0	36.8	41.6	48.4	63.0	69.3
		7.84	7.84	7.84	7.84	1.69				1.98	2.38	2.74	3.60	4.07	4.74	6.17	6.79	

- 1) Enter the phase & voltage code in the box (□) within the motor model name.
- 2) Enter the gear ratio in the box (□) within the Gearbox model name.
- 3) A colored background indicates gear shaft rotation in the same direction as the motor shaft; a white background indicates rotation in the opposite direction.
- 4) The rotating speed is calculated by dividing the motor's synchronous speed (50Hz: 1,500r/min, 60Hz: 1,800r/min) by the gear ratio.  
The actual speed is 2~20% less than the displayed value, depending on the size of the load.

# B AC Motors

## Reversible Motor 25W(□80mm)

### Dimensions

#### MOTOR ONLY

- MOTOR MODEL: 8RDD□-25(-T) (NO FAN)

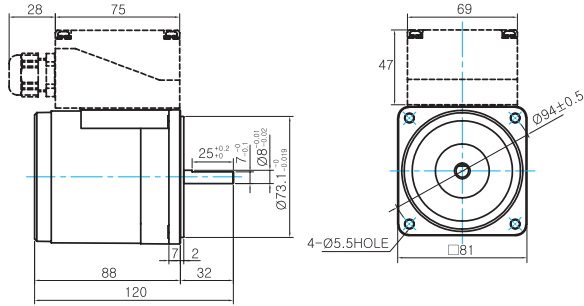

#### INTER-DECIMAL GEARBOX

- MODEL: 8XD10□□

#### MOTOR OUTPUT SHAFT

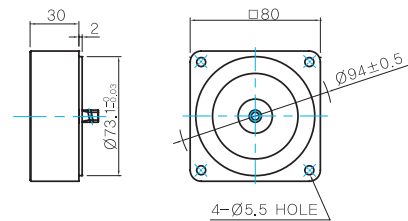
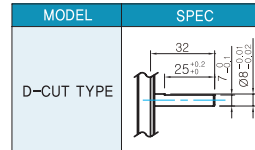

### GEARED MOTOR

#### G TYPE GEARBOX

- MOTOR MODEL: 8RDG□-25G (NO FAN)
- GEARBOX MODEL: 8GBK□BMH

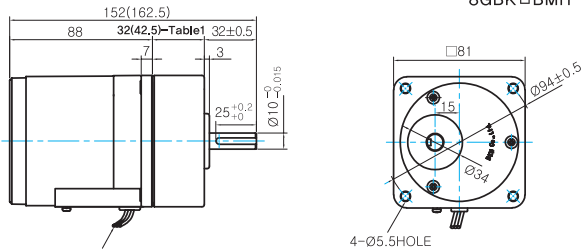

LEAD WIRE 300mm  
UL STYLE NO,3271 AWG NO,22

#### GEARBOX OUTPUT SHAFT

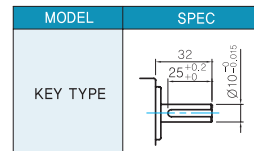

#### KEY SPEC

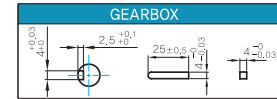

#### 30(40)-Table1

SIZE(mm)	GEAR RATIO
32	8GBK3BMH - 8GBK18BMH
42.5	8GBK25BMH - 8GBK360BMH

#### W TYPE GEARBOX

- MOTOR MODEL: 8RDG□-25W (NO FAN)
- GEARBOX MODEL: 8WD□BL/BR/BRL

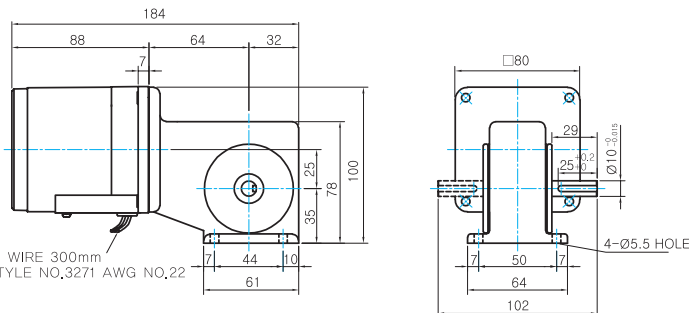

LEAD WIRE 300mm  
UL STYLE NO,3271 AWG NO,22

#### KEY SPEC

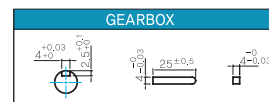

#### WEIGHT

PART	WEIGHT(Kg)	
MOTOR	1,6	
GEAR BOX	8GBK3BMH ~ 8GBK18BMH	0,48
	8GBK25BMH ~ 8GBK30BMH	0,61
	8GBK36BMH ~ 8GBK180BMH	0,67
	8GBK200BMH ~ 8GBK360BMH	0,63
	8WD□BL/BR/BRL	0,67
	8XD10M□□	0,44

## Motor Images

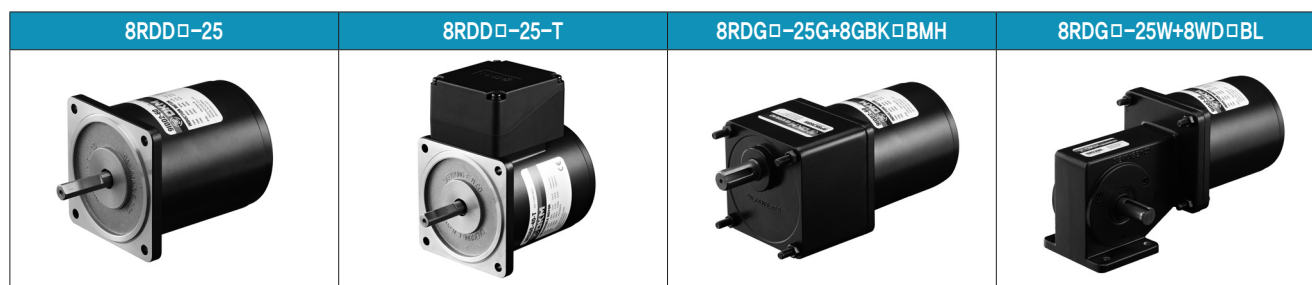

## Connection Diagrams

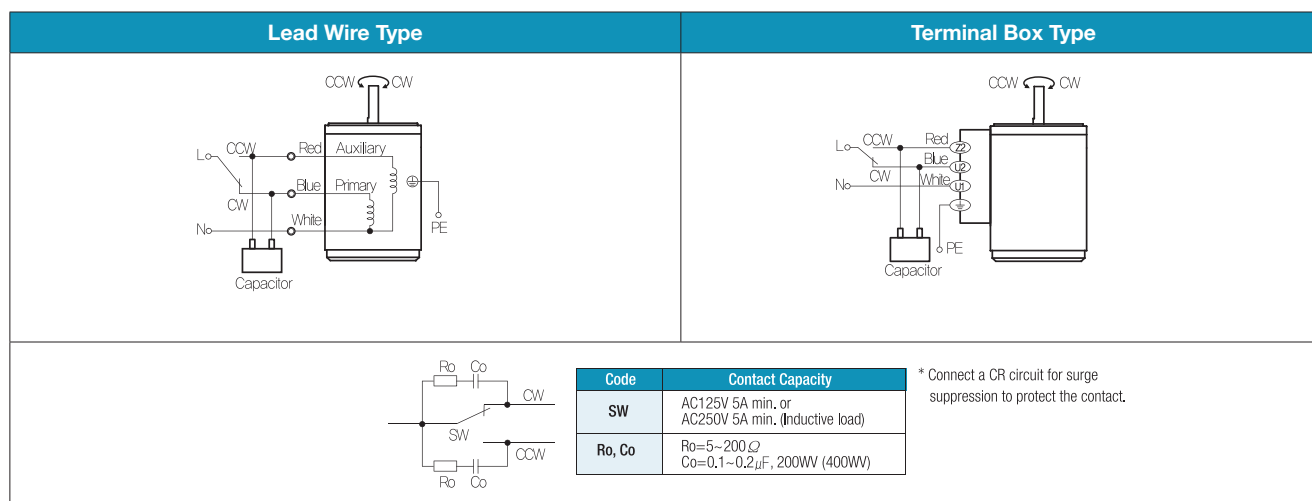

- 1) The direction of motor rotation is as viewed from the shaft end of the motor.
- 2) CW represents the clockwise direction, while CCW represents the counterclockwise direction.
- 3) During operation it is available to change the rotating direction by turning the switch to CW or CCW.



# B AC Motors

Reversible Motor 40W(□90mm)

## 40W Reversible Motor 40W(□90mm)

### Motor Specification

Model		Output W	Voltage V	Frequency Hz	Poles	Duty	Starting Torque		Rated Load				Capacitor μF / VAC	
Lead Wire Type	Terminal Box Type						kgfcm	N.m	Speed r/min	Current A	Torque kgfcm N.m			
9RDG*-40□(-T): Gear Type Shaft 9RDD*-40(-T): D-Cut Type Shaft 9RDK*-40(-T): Key Type Shaft														
9RDGA-40□	9RDGA-40□-T	40	1∅110	60	4	30min.	4.20	0.420	1600	1.25	2.60	0.260	16.0 / 250	
9RDGD-40□	9RDGD-40□-T	40	1∅220	60	4	30min.	4.20	0.420	1600	0.61	2.60	0.260	4.0 / 450	
9RDGE-40□	9RDGE-40□-T	40	1∅220	50	4	30min.	3.00	0.300	1350	0.36	3.00	0.300	3.0 / 450	
			1∅240				3.60	0.360						0.39

1) Enter the phase & voltage code in the place \* and enter the model type of attaching Gearbox in the box (□) within the motor model name.

2) All models contain a built-in thermal protector.

3) Gear Type Shaft is for attaching Gearbox and D-Cut & Key Type Shafts are for using motor only.

### Max. Permissible Torque at Output Shaft of Gearbox

#### 60Hz

Motor Model	Gearbox Model	Gear Ratio r/min	2	3	3.6	5	6	7.5	9	10	12.5	15	18	25	30	36	40	50	60	75	90	100	120	150	180	200
			kgfcm	600	500	360	300	240	200	180	144	120	100	72	60	50	45	36	30	24	20	18	15	12	10	9
9RDG□ -40G	9GBK□ BMH	kgfcm N.m	4.3 0.42	6.5 0.63	7.8 0.76	10.8 1.06	12.9 1.27	16.2 1.59	19.4 1.90	21.6 2.11	27.0 2.64	32.4 3.17	35.1 3.44	48.8 4.78	58.5 5.73	63.6 6.24	70.7 6.93	88.4 8.66	100.0 9.80	100.0 9.80	100.0 9.80	100.0 9.80	100.0 9.80	100.0 9.80	100.0 9.80	100.0 9.80

Motor Model	Gearbox Model	Gear Ratio r/min	10	12	15	18	25	30	36	50	60
			kgfcm	120	100	72	60	50	36	30	
9RDG□-40W	9WD□BL/□BR/ □BRL	kgfcm N.m	21.3 2.09	25.0 2.45	30.0 2.94	34.6 3.39	45.5 4.46	51.5 5.05	59.9 5.87	78.0 7.64	85.8 8.41

#### 50Hz

Motor Model	Gearbox Model	Gear Ratio r/min	2	3	3.6	5	6	7.5	9	10	12.5	15	18	25	30	36	40	50	60	75	90	100	120	150	180	200
			kgfcm	500	417	300	250	200	167	150	120	100	83	60	50	42	38	30	25	20	17	15	13	10	8	7.5
9RDG□ -40G	9GBK□ BMH	kgfcm N.m	5.6 0.55	8.5 0.83	10.2 1.00	14.1 1.38	16.9 1.66	21.2 2.07	25.4 2.49	28.2 2.77	35.3 3.46	42.3 4.15	45.9 4.50	63.8 6.25	76.5 7.50	83.2 8.16	92.5 9.06	100.0 9.80	100.0 9.80	100.0 9.80	100.0 9.80	100.0 9.80	100.0 9.80	100.0 9.80	100.0 9.80	

Motor Model	Gearbox Model	Gear Ratio r/min	10	12	15	18	25	30	36	50	60
			kgfcm	125	100	83	60	50	42	30	25
9RDG□-40W	9WD□BL/□BR/ □BRL	kgfcm N.m	27.9 2.73	32.6 3.20	39.3 3.85	45.3 4.44	59.5 5.83	67.3 6.60	78.3 7.68	102.0 10.00	112.2 11.00

1) Enter the phase & voltage code in the box (□) within the motor model name.

2) Enter the gear ratio in the box (□) within the Gearbox model name.

3) A colored background indicates gear shaft rotation in the same direction as the motor shaft; a white background indicates rotation in the opposite direction.

4) The rotating speed is calculated by dividing the motor's synchronous speed (50Hz: 1,500r/min, 60Hz: 1,800r/min) by the gear ratio. The actual speed is 2~20% less than the displayed value, depending on the size of the load.

## Dimensions

### MOTOR ONLY

- MOTOR MODEL: 9RDD□-40(-T) (NO FAN)

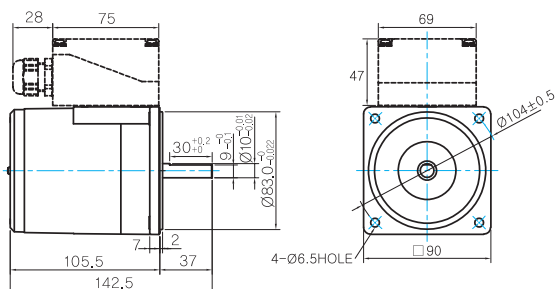

### MOTOR OUTPUT SHAFT

MODEL	SPEC
D-CUT TYPE	
9RDD□-40	
KEY TYPE	
9RDK□-40	

### INTER-DECIMAL GEARBOX

- MODEL: 9XD10□□

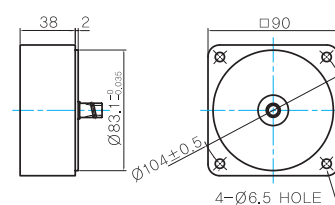

## GEARED MOTOR

### G TYPE GEARBOX

- MOTOR MODEL: 9RDG□-40G (NO FAN)
- GEARBOX MODEL: 9GBK□BMH

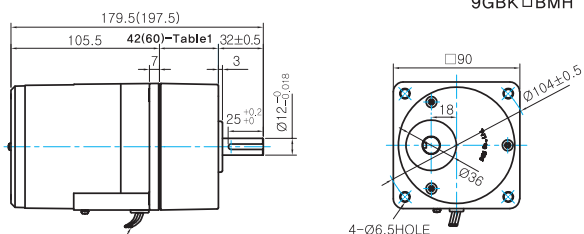

LEAD WIRE 300mm  
UL STYLE NO.3271 AWG NO.22

### GEARBOX OUTPUT SHAFT

MODEL	SPEC
KEY TYPE	

### KEY SPEC

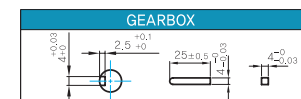

- 42(60)-Table1

SIZE(mm)	GEAR RATIO
42	9GBK2BMH - 9GBK18BMH
60	9GBK25BMH - 9GBK200BMH

### W TYPE GEARBOX

- MOTOR MODEL: 9RDG□-40W (NO FAN)
- GEARBOX MODEL: 9WD□BL/BR/BRL

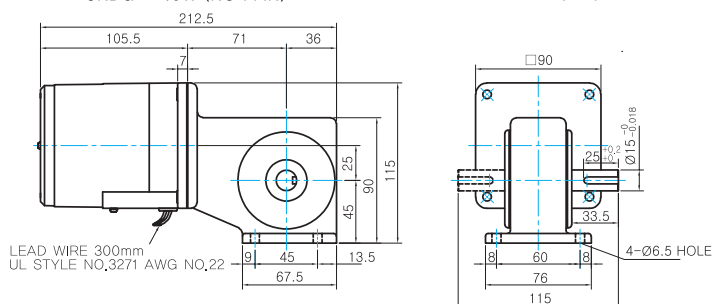

LEAD WIRE 300mm  
UL STYLE NO.3271 AWG NO.22

### KEY SPEC

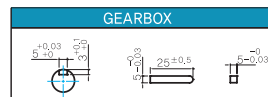

### WEIGHT

PART	WEIGHT(kg)	
MOTOR	2.4	
GEAR BOX	9GBK2BMH ~ 9GBK15BMH	0.67
	9GBK18BMH ~ 9GBK30BMH	0.96
	9GBK36BMH ~ 9GBK200BMH	1.07
	9WD□BL/BR/BRL	1.0
	9XD10□□	0.5

# B AC Motors

Reversible Motor 40W(□90mm)

## Motor Images

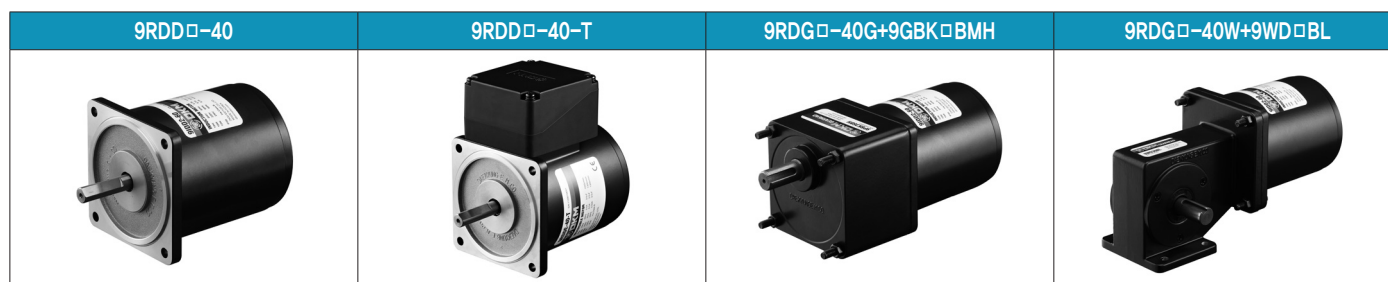

## Connection Diagrams

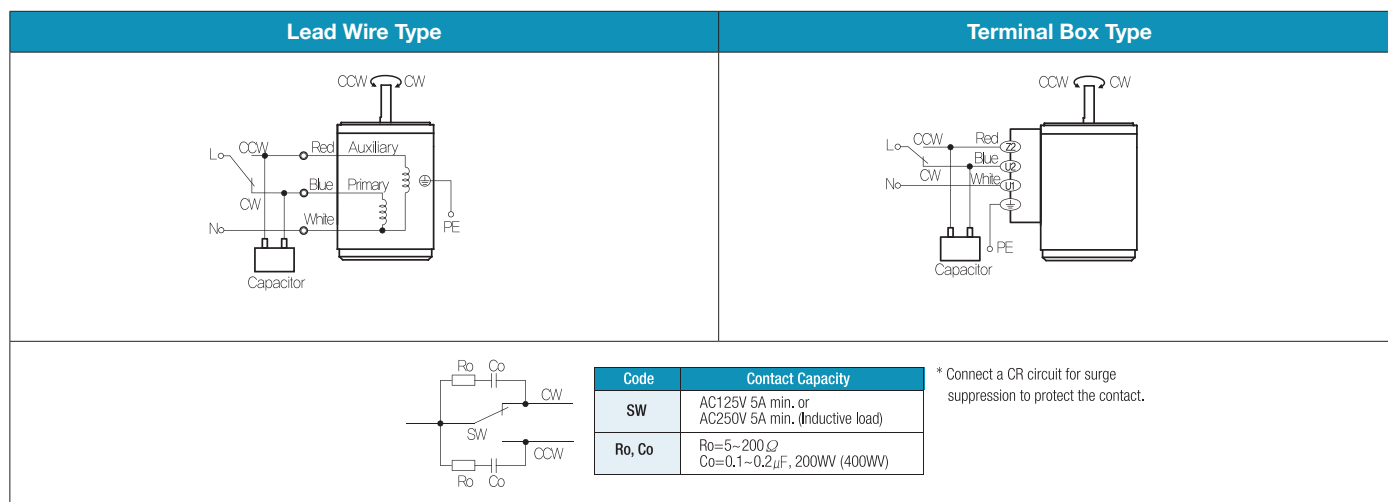

- 1) The direction of motor rotation is as viewed from the shaft end of the motor.
- 2) CW represents the clockwise direction, while CCW represents the counterclockwise direction.
- 3) During operation it is available to change the rotating direction by turning the switch to CW or CCW.

Reversible Motor 60W(□90mm)

**60W** Reversible Motor 60W(□90mm)

Reversible Motor 60W(□90mm)

**Motor Specification**

Model		Output W	Voltage V	Frequency Hz	Poles	Duty	Starting Torque		Rated Load				Capacitor µF / VAC
Lead Wire Type	Terminal Box Type						kgfcm	N.m	Speed r/min	Current A	Torque kgfcm N.m		
9RDG <sup>+</sup> -60F□(-T): Gear Type Shaft 9RDD <sup>+</sup> -60F(-T): D-Cut Type Shaft 9RDK <sup>+</sup> -60F(-T): Key Type Shaft													
9RDGA-60F□	9RDGA-60F□-T	60	1∅110	60	4	30min.	5.20	0.520	1600	1.60	5.00	0.500	20.0 / 250
9RDGD-60F□	9RDGD-60F□-T	60	1∅220	60	4	30min.	5.00	0.500	1600	0.75	4.60	0.460	5.0 / 450
9RDGE-60F□	9RDGE-60F□-T	60	1∅220	50	4	30min.	5.40	0.540	1300	0.59	5.00	0.500	5.0 / 450
			1∅240				6.60	0.660		0.64	5.60	0.560	

- 1) Enter the phase & voltage code in the place \* and enter the model type of attaching Gearbox in the box (□) within the motor model name.
- 2) All models contain a built-in thermal protector.
- 3) Gear Type Shaft is for attaching Gearbox and D-Cut & Key Type Shafts are for using motor only.

**Max. Permissible Torque at Output Shaft of Gearbox**

**60Hz**

Motor Model	Gearbox Model	Gear Ratio	2	3	3.6	5	6	7.5	9	12.5	15	18	20	25	30	36	40	50	60	75	90	100	120	150	180	200
9RDG□ -60FP	9PBK□BH 9PFK□BH	kgfcm	7.6	11.5	13.7	19.1	22.9	28.6	34.4	43.1	51.8	62.1	62.6	78.2	93.8	112.6	125.1	156.4	200.0	200.0	200.0	200.0	200.0	200.0	200.0	200.0
		N.m	0.75	1.12	1.35	1.87	2.24	2.81	3.37	4.23	5.07	6.09	6.13	7.66	9.20	11.04	12.26	15.33	19.60	19.60	19.60	19.60	19.60	19.60	19.60	19.60
9RDG□ -60FH	9HBK□BH 9HFK□BH	kgfcm	-	11.5	13.7	-	22.9	-	34.4	43.1	51.8	62.1	62.6	88.2	93.8	112.6	-	156.4	187.7	210.5	252.5	300.0	300.0	300.0	300.0	300.0
		N.m	-	1.12	1.35	-	2.24	-	3.37	4.23	5.07	6.09	6.13	7.66	9.20	11.04	-	15.33	18.39	20.62	24.75	29.40	29.40	29.40	29.40	29.40

Motor Model	Gearbox Model	Gear Ratio	10	12	15	18	25	30	36	50	60
9RDG□ -60FW	9WD□BL/ □BR/□BRL	kgfcm	37.7	44.2	53.1	61.3	80.5	91.1	106.0	142.9	122.4
		N.m	3.70	4.33	5.21	6.00	7.89	8.93	10.39	14.00	12.00

Motor Model	Gearbox Model	Gear Ratio	7.5	10	15	20	25	30	40	50	60	80
9RDG□ -60FWH	9WHD□ -030	kgfcm	29.0	37.3	52.4	66.2	75.9	88.3	108.6	124.2	138.0	132.7
		N.m	2.84	3.65	5.14	6.49	7.44	8.66	10.64	12.17	13.52	13.00

**50Hz**

Motor Model	Gearbox Model	Gear Ratio	2	3	3.6	5	6	7.5	9	12.5	15	18	20	25	30	36	40	50	60	75	90	100	120	150	180	200
9RDG□ -60FP	9PBK□BH 9PFK□BH	kgfcm	9.3	13.9	16.7	23.2	27.9	34.9	41.8	52.5	63.0	75.6	76.2	95.2	114.2	137.1	152.3	190.4	200.0	200.0	200.0	200.0	200.0	200.0	200.0	200.0
		N.m	0.91	1.37	1.64	2.28	2.73	3.42	4.10	5.15	6.17	7.41	7.46	9.33	11.20	13.43	14.93	18.66	19.60	19.60	19.60	19.60	19.60	19.60	19.60	19.60
9RDG□ -60FH	9HBK□BH 9HFK□BH	kgfcm	-	13.9	16.7	-	27.9	-	41.8	52.5	63.0	75.6	76.2	95.2	114.2	137.1	-	190.4	228.5	256.2	300.0	300.0	300.0	300.0	300.0	300.0
		N.m	-	1.37	1.64	-	2.73	-	4.10	5.15	6.17	7.41	7.46	9.33	11.20	13.43	-	18.66	22.39	25.11	29.40	29.40	29.40	29.40	29.40	29.40

Motor Model	Gearbox Model	Gear Ratio	10	12	15	18	25	30	36	50	60
9RDG□ -60FW	9WD□BL/ □BR/□BRL	kgfcm	45.9	53.8	64.7	74.6	98.0	110.9	129.0	142.9	122.4
		N.m	4.50	5.27	6.34	7.31	9.60	10.87	12.64	14.00	12.00

Motor Model	Gearbox Model	Gear Ratio	7.5	10	15	20	25	30	40	50	60	80
9RDG□ -60FWH	9WHD□ -030	kgfcm	35.3	45.4	63.8	80.6	92.4	107.5	132.2	151.2	163.3	132.7
		N.m	3.46	4.45	6.26	7.90	9.06	10.54	12.95	14.82	16.00	13.00

- 1) Enter the phase & voltage code in the box (□) within the motor model name.
- 2) Enter the gear ratio in the box (□) within the Gearbox model name.
- 3) A colored background indicates gear shaft rotation in the same direction as the motor shaft; a white background indicates rotation in the opposite direction.
- 4) The rotating speed is calculated by dividing the motor's synchronous speed (50Hz: 1,500r/min, 60Hz: 1,800r/min) by the gear ratio. The actual speed is 2~20% less than the displayed value, depending on the size of the load.

# B AC Motors

## Reversible Motor 60W(□90mm)

### Dimensions

#### MOTOR ONLY

- MOTOR MODEL: 9RDD□-60F(-T) (GENERAL FAN)

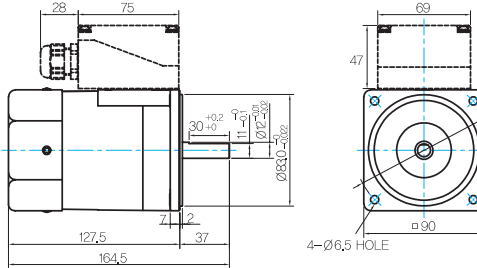

#### MOTOR OUTPUT SHAFT

MODEL	SPEC
D-CUT TYPE	37
9RDD□-60F	30 <sup>+0.2</sup> / <sub>0</sub> , 11 <sup>+0.03</sup> / <sub>0</sub> , Ø12 <sup>+0.03</sup> / <sub>0</sub>
KEY TYPE	37
9RDK□-60F	25 <sup>+0.2</sup> / <sub>0</sub> , 11 <sup>+0.03</sup> / <sub>0</sub> , Ø12 <sup>+0.03</sup> / <sub>0</sub>

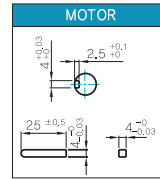

#### INTER-DECIMAL GEARBOX

- MODEL: 9XD10□□

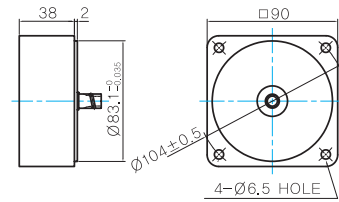

### GEARED MOTOR

#### P TYPE GEARBOX

- MOTOR MODEL: 9RDG□-60FP (GENERAL FAN)

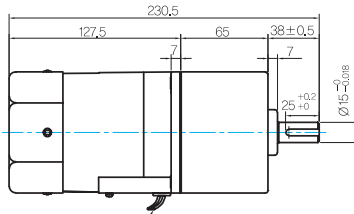

LEAD WIRE 300mm  
UL STYLE NO.3271 AWG NO.22

- GEARBOX MODEL: 9PBK□BH

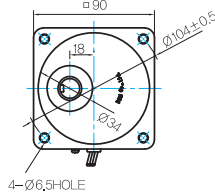

- GEARBOX MODEL: 9PFB□BH

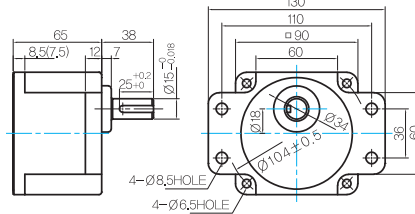

#### GEARBOX OUTPUT SHAFT

MODEL	SPEC
KEY TYPE	38
9PBK□BH	25 <sup>+0.2</sup> / <sub>0</sub> , 11 <sup>+0.03</sup> / <sub>0</sub> , Ø12 <sup>+0.03</sup> / <sub>0</sub>
9PFB□BH	

#### KEY SPEC

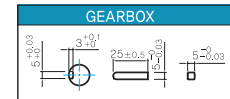

#### H TYPE GEARBOX

- MOTOR MODEL: 9RDG□-60FH (GENERAL FAN)

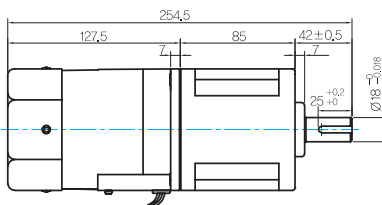

LEAD WIRE 300mm  
UL STYLE NO.3271 AWG NO.22

- GEARBOX MODEL: 9HBK□BH

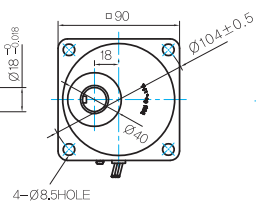

- GEARBOX MODEL: 9HFK□BH

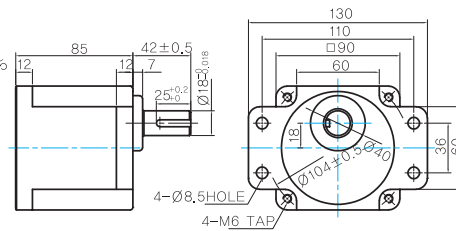

#### GEARBOX OUTPUT SHAFT

MODEL	SPEC
KEY TYPE	42
9HBK□BH	25 <sup>+0.2</sup> / <sub>0</sub> , 11 <sup>+0.03</sup> / <sub>0</sub> , Ø12 <sup>+0.03</sup> / <sub>0</sub>
9HFK□BH	

#### KEY SPEC

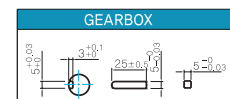

#### W TYPE GEARBOX

- MOTOR MODEL: 9RDG□-60FW (GENERAL FAN)

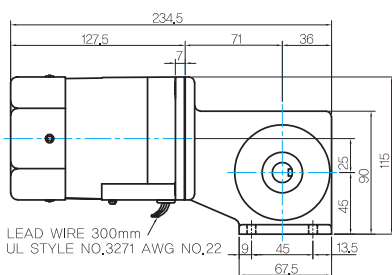

LEAD WIRE 300mm  
UL STYLE NO.3271 AWG NO.22

- GEARBOX MODEL: 9WD□BL/BR/BRL

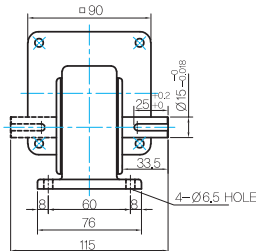

#### KEY SPEC

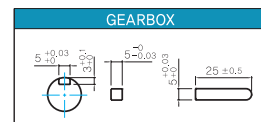

● MOTOR MODEL:  
9RDG□-90FWH (GENERAL FAN)

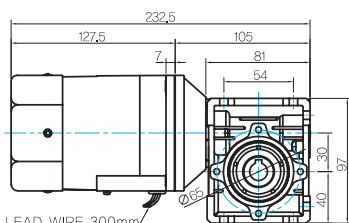

● GEARBOX MODEL:  
9WHD□-030

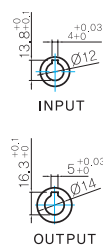
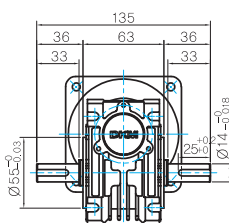

● SHAFT(Unidirectional, Bi-directional)

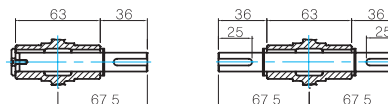

● WEIGHT

PART	WEIGHT(Kg)	
MOTOR	3,0	
GEAR BOX	9PB(F)K2BH ~ 9PB(F)K18BH	1,3
	9PB(F)K20BH ~ 9PB(F)K200BH	1,4
	9HB(F)K3BH ~ 9HB(F)K9BH	1,45
	9HB(F)K12.5BH ~ 9HB(F)K18BH	1,5
	9HB(F)K20BH ~ 9HB(F)K60BH	1,7
	9HB(F)K75BH ~ 9HB(F)K200BH	1,8
	9WD□BL/BR/BRL	1,0
	9WHD□-030	1,13
	9XD10□□	0,5

● FLANGE

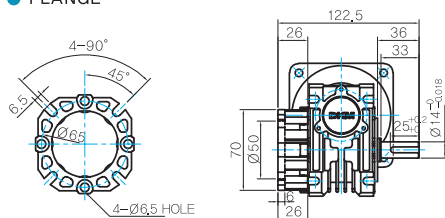

● KEY SPEC

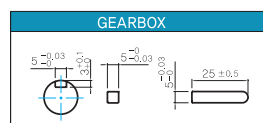

\* The output flange and shafts are sold separately.

● Motor Images

9RDD□-60F	9RDD□-60F-T	9RDG□-60FP+9PBK□BH	9RDG□-60FP+9PFK□BH
9RDG□-60FH+9HBK□BH	9RDG□-60FH+9HFK□BH	9RDG□-60FW+9WD□BL	9RDG□-60FWH+9WHD□

# B AC Motors

Reversible Motor 60W(□90mm)

## Connection Diagrams

Lead Wire Type	Terminal Box Type						
	<table border="1" style="margin-left: auto; margin-right: auto;"> <thead> <tr style="background-color: #0070C0; color: white;"> <th>Code</th> <th>Contact Capacity</th> </tr> </thead> <tbody> <tr> <td style="text-align: center;"><b>SW</b></td> <td>AC125V 5A min. or AC250V 5A min. (Inductive load)</td> </tr> <tr> <td style="text-align: center;"><b>Ro, Co</b></td> <td>Ro=5~200Ω Co=0.1~0.2μF, 200W (400W)</td> </tr> </tbody> </table> <p style="font-size: small; margin-top: 5px;">* Connect a CR circuit for surge suppression to protect the contact.</p>	Code	Contact Capacity	<b>SW</b>	AC125V 5A min. or AC250V 5A min. (Inductive load)	<b>Ro, Co</b>	Ro=5~200Ω Co=0.1~0.2μF, 200W (400W)
Code	Contact Capacity						
<b>SW</b>	AC125V 5A min. or AC250V 5A min. (Inductive load)						
<b>Ro, Co</b>	Ro=5~200Ω Co=0.1~0.2μF, 200W (400W)						

- 1) The direction of motor rotation is as viewed from the shaft end of the motor.
- 2) CW represents the clockwise direction, while CCW represents the counterclockwise direction.
- 3) During operation it is available to change the rotating direction by turning the switch to CW or CCW.



Reversible Motor 90W(□90mm)

# 90W Reversible Motor 90W(□90mm)

Reversible Motor 90W(□90mm)

## Motor Specification

Model		Output W	Voltage V	Frequency Hz	Poles	Duty	Starting Torque		Rated Load			Capacitor μF / VAC	
Lead Wire Type	Terminal Box Type						kgfcm	N.m	Speed r/min	Current A	Torque kgfcm N.m		
9RDG*~90F□(-T): Gear Type Shaft 9RDD*~90F(-T): D-Cut Type Shaft 9RDK*~90F(-T): Key Type Shaft													
9RDGA-90F□	9RDGA-90F□-T	90	1∅110	60	4	30min.	6.60	0.660	1600	2.00	6.40	0.640	25.0 / 250
9RDGD-90F□	9RDGD-90F□-T	90	1∅220	60	4	30min.	6.00	0.600	1600	0.97	6.60	0.660	6.0 / 450
9RDGE-90F□	9RDGE-90F□-T	90	1∅220 1∅240	50	4	30min.	6.40 7.80	0.640 0.780	1250	0.90 1.00	7.80 8.90	0.780 0.890	6.0 / 450

- 1) Enter the phase & voltage code in the place \* and enter the model type of attaching Gearbox in the box (□) within the motor model name.
- 2) All models contain a built-in thermal protector.
- 3) Gear Type Shaft is for attaching Gearbox and D-Cut & Key Type Shafts are for using motor only.

## Max. Permissible Torque at Output Shaft of Gearbox

### 60Hz

Motor Model	Gearbox Model	Gear Ratio r/min	2	3	3.6	5	6	7.5	9	12.5	15	18	20	25	30	36	40	50	60	75	90	100	120	150	180	200
			900	600	500	360	300	240	200	144	120	100	90	72	60	50	45	36	30	24	20	18	15	12	10	9
9RDG□ -90FP	9PBK□BH 9PFK□BH	kgfcm N.m	11.0 1.07	16.4 1.61	19.7 1.93	27.4 2.68	32.9 3.22	41.1 4.03	49.3 4.83	61.9 6.06	74.3 7.28	89.1 8.73	89.76 8.80	112.2 11.00	134.6 13.19	161.1 15.83	179.5 17.59	200.0 19.60	200.0 19.60	200.0 19.60	200.0 19.60	200.0 19.60	200.0 19.60	200.0 19.60	200.0 19.60	200.0 19.60
9RDG□ -90FH	9HBK□BH 9HFK□BH	kgfcm N.m	- 1.61	16.4 1.93	19.7 1.93	- 3.22	32.9 3.22	- 4.83	49.3 6.06	61.9 7.28	74.3 8.73	89.1 8.73	89.8 8.80	112.2 11.00	134.6 13.19	161.6 15.83	- -	224.4 21.99	269.3 26.39	300.0 29.40	300.0 29.40	300.0 29.40	300.0 29.40	300.0 29.40	300.0 29.40	300.0 29.40

Motor Model	Gearbox Model	Gear Ratio r/min	10	12	15	18	25	30	36	50	60
			180	150	120	100	72	60	50	36	30
9RDG□ -90FW	9WD□BL/ □BR/□BRL	kgfcm N.m	54.1 5.30	63.4 6.21	76.2 7.47	87.9 8.62	115.5 11.32	130.7 12.81	153.1 15.00	142.9 14.00	122.4 12.00

Motor Model	Gearbox Model	Gear Ratio r/min	7.5	10	15	20	25	30	40	50	60	80
			240	180	120	90	72	60	45	36	30	22
9RDG□ -90FWH	9WHD□ -030	kgfcm N.m	41.6 4.07	53.5 5.24	75.2 7.37	95.0 9.31	108.9 10.67	126.7 12.42	155.8 15.26	173.5 17.00	163.3 16.00	132.7 13.00

### 50Hz

Motor Model	Gearbox Model	Gear Ratio r/min	2	3	3.6	5	6	7.5	9	12.5	15	18	20	25	30	36	40	50	60	75	90	100	120	150	180	200
			750	500	417	300	250	200	167	120	100	83	75	60	50	42	38	30	25	20	17	15	13	10	8	7.5
9RDG□ -90FP	9PBK□BH 9PFK□BH	kgfcm N.m	12.9 1.27	19.4 1.90	23.3 2.28	32.4 3.17	38.8 3.81	48.6 4.76	58.3 5.71	73.1 7.17	87.8 8.60	105.3 10.32	106.1 10.40	132.6 12.99	159.1 15.59	190.9 18.71	200.0 19.60	200.0 19.60	200.0 19.60	200.0 19.60	200.0 19.60	200.0 19.60	200.0 19.60	200.0 19.60	200.0 19.60	200.0 19.60
9RDG□ -90FH	9HBK□BH 9HFK□BH	kgfcm N.m	- 1.90	19.4 2.28	23.3 2.28	- 3.81	38.8 3.81	- 4.76	58.3 5.71	73.1 7.17	87.8 8.60	105.3 10.32	106.1 10.40	132.6 12.99	159.1 15.59	190.9 18.71	- -	265.2 25.99	300.0 29.40	300.0 29.40	300.0 29.40	300.0 29.40	300.0 29.40	300.0 29.40	300.0 29.40	300.0 29.40

Motor Model	Gearbox Model	Gear Ratio r/min	10	12	15	18	25	30	36	50	60
			150	125	100	83	60	50	42	30	25
9RDG□ -90FW	9WD□BL/ □BR/□BRL	kgfcm N.m	64.0 6.27	74.9 7.34	90.1 8.83	103.9 10.18	136.5 13.38	154.4 15.14	153.1 15.00	142.9 14.00	122.4 12.00

Motor Model	Gearbox Model	Gear Ratio r/min	7.5	10	15	20	25	30	40	50	60	80
			200	150	100	75	60	50	38	30	25	18
9RDG□ -90FWH	9WHD□ -030	kgfcm N.m	49.1 4.82	63.2 6.19	88.9 8.71	112.3 11.01	128.7 12.61	149.8 14.68	183.7 18.00	173.5 17.00	163.3 16.00	132.7 13.00

- 1) Enter the phase & voltage code in the box (□) within the motor model name.
- 2) Enter the gear ratio in the box (□) within the Gearbox model name.
- 3) A colored background indicates gear shaft rotation in the same direction as the motor shaft; a white background indicates rotation in the opposite direction.
- 4) The rotating speed is calculated by dividing the motor's synchronous speed (50Hz: 1,500r/min, 60Hz: 1,800r/min) by the gear ratio.  
The actual speed is 2-20% less than the displayed value, depending on the size of the load.



# B AC Motors

## Reversible Motor 90W(□90mm)

### Dimensions

#### MOTOR ONLY

- MOTOR MODEL: 9RDD□-90F(-T) (GENERAL FAN)

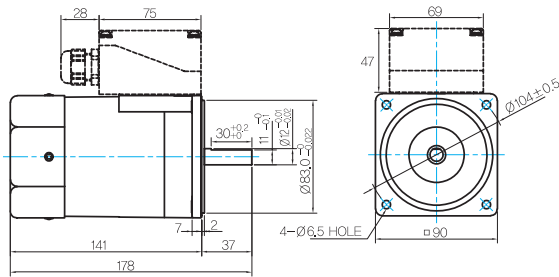

#### MOTOR OUTPUT SHAFT

MODEL	SPEC
D-CUT TYPE	
9RDD□-90F	
KEY TYPE	
9RDK□-90F	

#### KEY SPEC

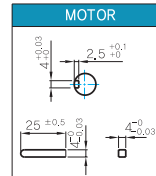

#### INTER-DECIMAL GEARBOX

- MODEL: 9XD10□□

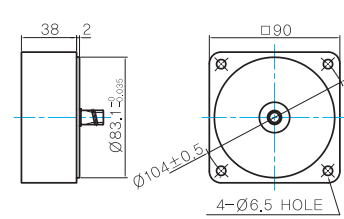

### GEARED MOTOR

#### P TYPE GEARBOX

- MOTOR MODEL: 9RDG□-90FP (GENERAL FAN)

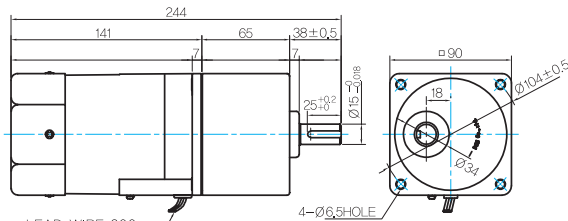

LEAD WIRE 300mm  
UL STYLE NO,3271 AWG NO,22

- GEARBOX MODEL: 9PBK□BH

- GEARBOX MODEL: 9PFK□BHI

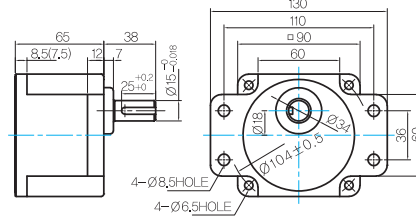

#### GEARBOX OUTPUT SHAFT

MODEL	SPEC
KEY TYPE	
9PBK□BH	
9PFK□BH	

#### KEY SPEC

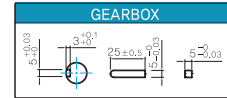

#### H TYPE GEARBOX

- MOTOR MODEL: 9RDG□-90FH (GENERAL FAN)

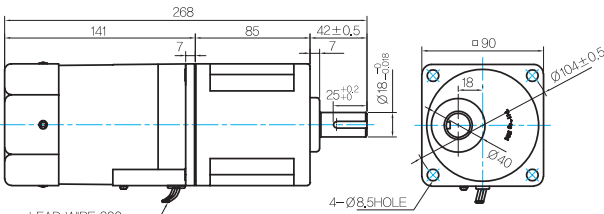

LEAD WIRE 300mm  
UL STYLE NO,3271 AWG NO,22

- GEARBOX MODEL: 9HBK□BH

- GEARBOX MODEL: 9HFK□BH

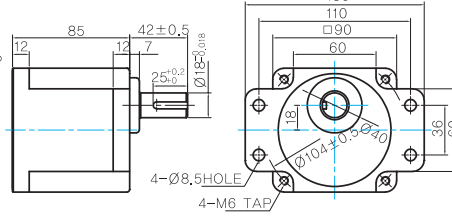

#### GEARBOX OUTPUT SHAFT

MODEL	SPEC
KEY TYPE	
9HBK□BH	
9HFK□BH	

#### KEY SPEC

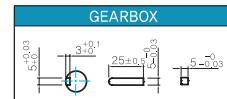

#### W TYPE GEARBOX

- MOTOR MODEL: 9RDG□-90FW (GENERAL FAN)

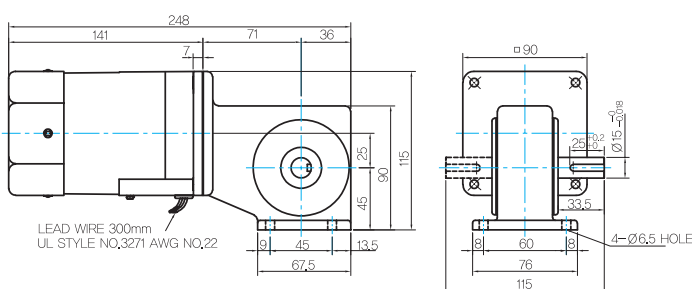

LEAD WIRE 300mm  
UL STYLE NO,3271 AWG NO,22

- GEARBOX MODEL: 9WD□BL/BR/BRL

#### KEY SPEC

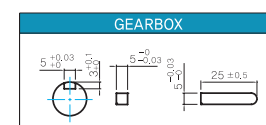

● MOTOR MODEL:  
9RDG□-90FWH (GENERAL FAN)

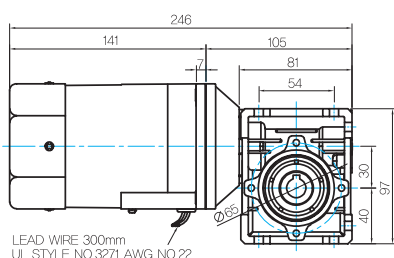

● GEARBOX MODEL:  
9WHD□-030

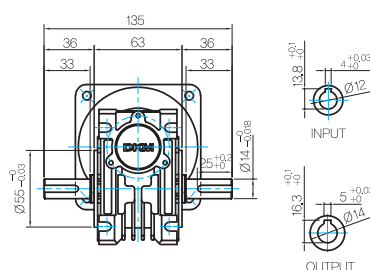

● SHAFT(Unidirectional, Bi-directional)

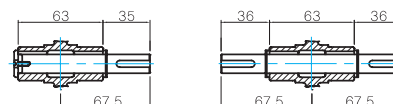

● FLANGE

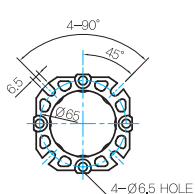

● KEY SPEC

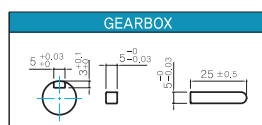

\* The output flange and shafts are sold separately.

● WEIGHT

PART	WEIGHT(Kg)
MOTOR	3,0
9PB(F)K2BH ~ 9PB(F)K18BH	1,3
9PB(F)K20BH ~ 9PB(F)K200BH	1,4
9HB(F)K3BH ~ 9HB(F)K9BH	1,45
9HB(F)K12.5BH ~ 9HB(F)K18BH	1,5
9HB(F)K20BH ~ 9HB(F)K60BH	1,7
9HB(F)K75BH ~ 9HB(F)K200BH	1,8
9WD□BL/BR/BRL	1,0
9WHD□-030	1,13
9XD10□	0,5

**Motor Images**

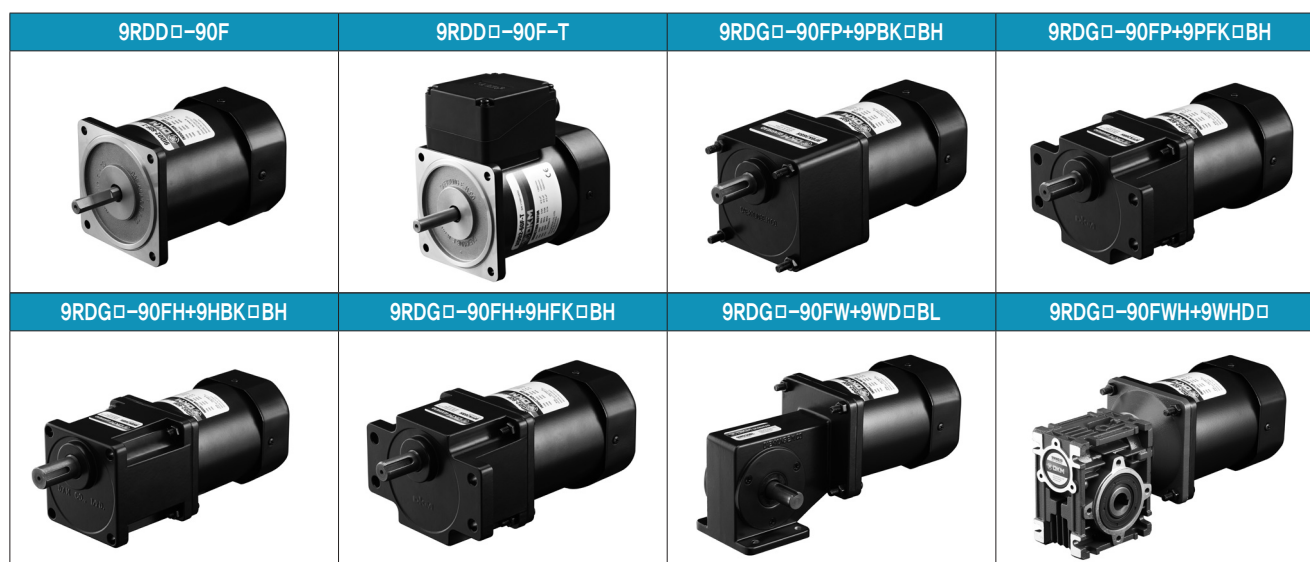

# B AC Motors

Reversible Motor 90W(□90mm)

## Connection Diagrams

Lead Wire Type	Terminal Box Type						
<table border="1"> <thead> <tr> <th style="background-color: #0070C0; color: white;">Code</th> <th style="background-color: #0070C0; color: white;">Contact Capacity</th> </tr> </thead> <tbody> <tr> <td style="text-align: center;"><b>SW</b></td> <td>AC125V 5A min. or AC250V 5A min. (Inductive load)</td> </tr> <tr> <td style="text-align: center;"><b>Ro, Co</b></td> <td>Ro=5~200Ω Co=0.1~0.2μF, 200W (400W)</td> </tr> </tbody> </table>		Code	Contact Capacity	<b>SW</b>	AC125V 5A min. or AC250V 5A min. (Inductive load)	<b>Ro, Co</b>	Ro=5~200Ω Co=0.1~0.2μF, 200W (400W)
Code	Contact Capacity						
<b>SW</b>	AC125V 5A min. or AC250V 5A min. (Inductive load)						
<b>Ro, Co</b>	Ro=5~200Ω Co=0.1~0.2μF, 200W (400W)						
<p>* Connect a CR circuit for surge suppression to protect the contact.</p>							

- 1) The direction of motor rotation is as viewed from the shaft end of the motor.
- 2) CW represents the clockwise direction, while CCW represents the counterclockwise direction.
- 3) During operation it is available to change the rotating direction by turning the switch to CW or CCW.

Reversible Motor 120W(□90mm)

# 120W

Reversible Motor  
120W(□90mm)

Reversible Motor 120W(□90mm)

## Motor Specification

Model		Output W	Voltage V	Frequency Hz	Poles	Duty	Starting Torque		Rated Load				Capacitor µF / VAC
Lead Wire Type	Terminal Box Type						kgfcm	N.m	Speed r/min	Current A	Torque kgfcm N.m		
9RDG*-120F□(-T): Gear Type Shaft 9RDD*-120F(-T): D-Cut Type Shaft 9RDK*-120F(-T): Key Type Shaft													
9RDGA-120F□	9RDGA-120F□-T	120	1∅110	60	4	30min.	7.60	0.760	1550	2.50	7.60	0.760	30.0 / 250
9RDGD-120F□	9RDGD-120F□-T	120	1∅220	60	4	30min.	6.60	0.660	1600	1.10	7.40	0.740	6.5 / 450
9RDGE-120F□	9RDGE-120F□-T	120	1∅220	50	4	30min.	6.40	0.640	1250	1.10	9.40	0.940	6.5 / 450
			1∅240				7.80	0.780			10.20	1.020	

- 1) Enter the phase & voltage code in the place \* and enter the model type of attaching Gearbox in the box (□) within the motor model name.
- 2) All models contain a built-in thermal protector.
- 3) Gear Type Shaft is for attaching Gearbox and D-Cut & Key Type Shafts are for using motor only.

## Max. Permissible Torque at Output Shaft of Gearbox

### 60Hz

Motor Model	Gearbox Model	Gear Ratio	Gear Ratio																							
			2	3	3.6	5	6	7.5	9	12.5	15	18	20	25	30	36	40	50	60	75	90	100	120	150	180	200
9RDG□ -120FP	9PBK□BH 9PFK□BH	kgfcm	12.3	18.4	22.1	30.7	36.9	46.1	55.3	69.4	83.3	99.9	100.6	125.8	151.0	181.2	200.0	200.0	200.0	200.0	200.0	200.0	200.0	200.0	200.0	200.0
		N.m	1.20	1.81	2.17	3.01	3.61	4.51	5.42	6.80	8.16	9.79	9.86	12.33	14.79	17.75	19.60	19.60	19.60	19.60	19.60	19.60	19.60	19.60	19.60	19.60
9RDG□ -120FH	9HBK□BH 9HFK□BH	kgfcm	-	18.4	22.1	-	36.9	-	55.3	69.4	83.3	99.9	100.6	125.8	151.0	181.2	-	251.6	300.0	300.0	300.0	300.0	300.0	300.0	300.0	300.0
		N.m	-	1.81	2.17	-	3.61	-	5.42	6.80	8.16	9.79	9.86	12.33	14.79	17.75	-	24.66	29.40	29.40	29.40	29.40	29.40	29.40	29.40	29.40

Motor Model	Gearbox Model	Gear Ratio	Gear Ratio								Motor Model	Gearbox Model	Gear Ratio	Gear Ratio										
			10	12	15	18	25	30	36	50				60	7.5	10	15	20	25	30	40	50	60	80
9RDG□ -120FW	9WD□BL/ □BR/□BRL	kgfcm	60.7	71.0	85.5	98.6	129.5	146.5	153.1	142.9	122.4	9RDG□ -120FWH	9WHD□ -030	kgfcm	46.6	59.9	84.4	106.6	122.1	142.1	174.6	173.5	163.3	132.7
		N.m	5.95	6.96	8.38	9.66	12.69	14.36	15.00	14.00	12.00			N.m	4.57	5.87	8.27	10.44	11.97	13.92	17.11	17.00	16.00	13.00

### 50Hz

Motor Model	Gearbox Model	Gear Ratio	Gear Ratio																							
			2	3	3.6	5	6	7.5	9	12.5	15	18	20	25	30	36	40	50	60	75	90	100	120	150	180	200
9RDG□ -120FP	9PBK□BH 9PFK□BH	kgfcm	15.6	23.4	28.1	39.0	46.8	58.5	70.2	88.1	105.8	126.9	127.8	159.8	191.8	200.0	200.0	200.0	200.0	200.0	200.0	200.0	200.0	200.0	200.0	200.0
		N.m	1.53	2.29	2.75	3.82	4.59	5.73	6.88	8.64	10.36	12.44	12.53	15.66	18.79	19.60	19.60	19.60	19.60	19.60	19.60	19.60	19.60	19.60	19.60	19.60
9RDG□ -120FH	9HBK□BH 9HFK□BH	kgfcm	-	23.4	28.1	-	46.8	-	70.2	88.1	105.8	126.9	127.8	159.8	191.8	230.1	-	300.0	300.0	300.0	300.0	300.0	300.0	300.0	300.0	300.0
		N.m	-	2.29	2.75	-	4.59	-	6.88	8.64	10.36	12.44	12.53	15.66	18.79	22.55	-	29.40	29.40	29.40	29.40	29.40	29.40	29.40	29.40	29.40

Motor Model	Gearbox Model	Gear Ratio	Gear Ratio								Motor Model	Gearbox Model	Gear Ratio	Gear Ratio										
			10	12	15	18	25	30	36	50				60	7.5	10	15	20	25	30	40	50	60	80
9RDG□ -90FW	9WD□BL/ □BR/□BRL	kgfcm	77.1	90.2	108.6	125.2	142.9	163.3	153.1	142.9	122.4	9RDG□ -120FWH	9WHD□ -030	kgfcm	59.2	76.1	107.2	135.4	155.1	180.5	183.7	173.5	163.3	132.7
		N.m	7.55	8.84	10.64	12.27	14.00	16.00	15.00	14.00	12.00			N.m	5.80	7.46	10.50	13.27	15.20	17.69	18.00	17.00	16.00	13.00

- 1) Enter the phase & voltage code in the box (□) within the motor model name.
- 2) Enter the gear ratio in the box (□) within the Gearbox model name.
- 3) A colored background indicates gear shaft rotation in the same direction as the motor shaft; a white background indicates rotation in the opposite direction.
- 4) The rotating speed is calculated by dividing the motor's synchronous speed (50Hz: 1,500r/min, 60Hz: 1,800r/min) by the gear ratio. The actual speed is 2~20% less than the displayed value, depending on the size of the load.

# B AC Motors

## Reversible Motor 120W(□90mm)

### Dimensions

#### MOTOR ONLY

- MOTOR MODEL: 9RDD□-120F(-T) (GENERAL FAN)

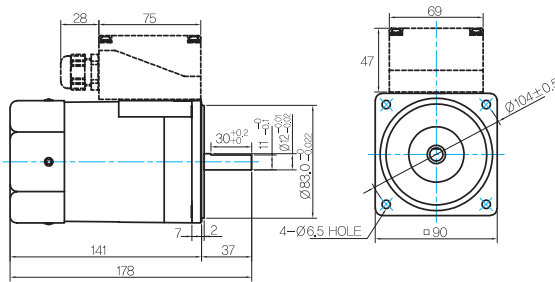

#### MOTOR OUTPUT SHAFT

MODEL	SPEC
D-CUT TYPE	37
9RDD□-120F	30 <sup>+0.2</sup> 11 <sup>+0.05</sup> 11 <sup>+0.05</sup>
KEY TYPE	37
9RDK□-120F	25 <sup>+0.2</sup> 11 <sup>+0.05</sup> 11 <sup>+0.05</sup>

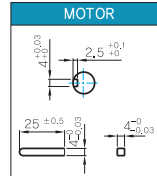

#### INTER-DECIMAL GEARBOX

- MODEL: 9XD10□□

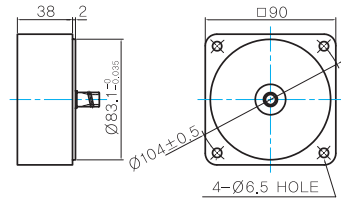

### GEARED MOTOR

#### P TYPE GEARBOX

- MOTOR MODEL: 9RDG□-120FP (GENERAL FAN)

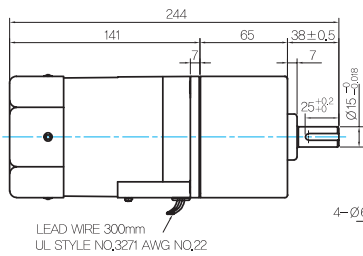

- GEARBOX MODEL: 9PBK□BH

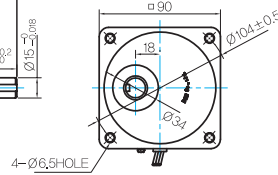

- GEARBOX MODEL: 9PFK□BHI

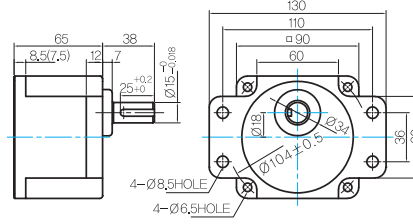

#### GEARBOX OUTPUT SHAFT

MODEL	SPEC
KEY TYPE	38
9PBK□BH	25 <sup>+0.2</sup> 11 <sup>+0.05</sup> 11 <sup>+0.05</sup>
9PFK□BHI	25 <sup>+0.2</sup> 11 <sup>+0.05</sup> 11 <sup>+0.05</sup>

#### KEY SPEC

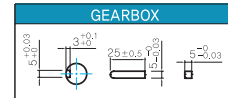

#### H TYPE GEARBOX

- MOTOR MODEL: 9RDG□-120FH (GENERAL FAN)

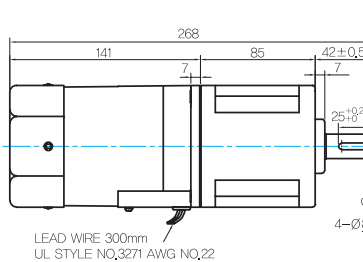

- GEARBOX MODEL: 9HBK□BH

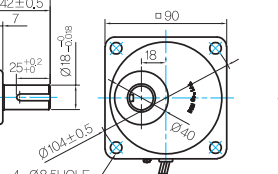

- GEARBOX MODEL: 9HFK□BH

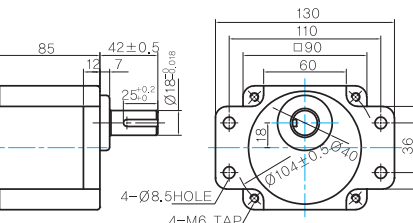

#### GEARBOX OUTPUT SHAFT

MODEL	SPEC
KEY TYPE	42
9HBK□BH	25 <sup>+0.2</sup> 11 <sup>+0.05</sup> 11 <sup>+0.05</sup>
9HFK□BH	25 <sup>+0.2</sup> 11 <sup>+0.05</sup> 11 <sup>+0.05</sup>

#### KEY SPEC

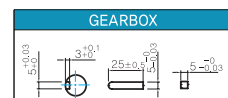

#### W TYPE GEARBOX

- MOTOR MODEL: 9RDG□-120FW (GENERAL FAN)

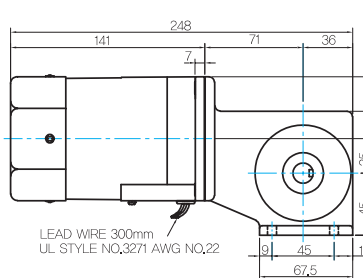

- GEARBOX MODEL: 9WD□BL/BR/BRL

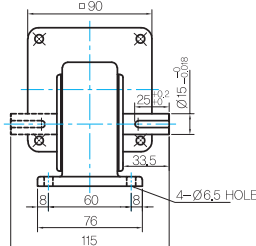

#### KEY SPEC

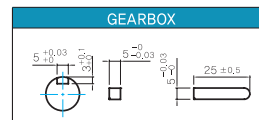

● MOTOR MODEL:  
9RDG□-120FWH (GENERAL FAN)

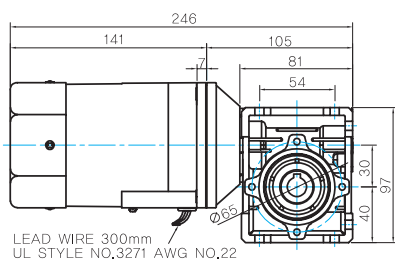

● GEARBOX MODEL:  
9WHD□-030

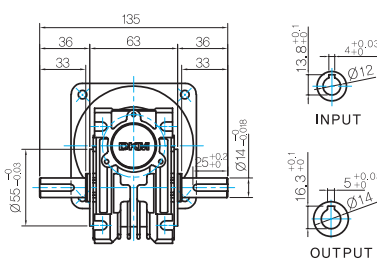

● SHAFT(Unidirectional, Bi-directional)

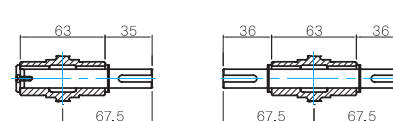

● WEIGHT

PART	WEIGHT(Kg)	
MOTOR	3,0	
GEAR BOX	9PB(F)K2BH ~ 9PB(F)K18BH	1,3
	9PB(F)K20BH ~ 9PB(F)K200BH	1,4
	9HB(F)K3BH ~ 9HB(F)K9BH	1,45
	9HB(F)K12,5BH ~ 9HB(F)K18BH	1,5
	9HB(F)K20BH ~ 9HB(F)K60BH	1,7
	9HB(F)K75BH ~ 9HB(F)K200BH	1,8
	9WD□BL/BR/BRL	1,0
	9WHD□-030	1,13
	9XD10□□	0,5

● FLANGE

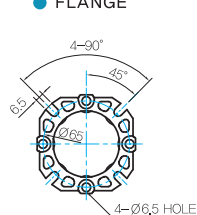

● KEY SPEC

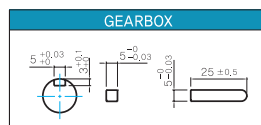

\* The output flange and shafts are sold separately.

Motor Images

9RDD□-120F	9RDD□-120F-T	9RDG□-120FP+9PBK□BH	9RDG□-120FP+9PFK□BH
9RDG□-120FH+9HBK□BH	9RDG□-120FH+9HFK□BH	9RDG□-120FW+9WD□BL	9RDG□-120FWH+9WHD□

# B AC Motors

## Reversible Motor 120W(90mm)

### Connection Diagrams

Lead Wire Type	Terminal Box Type						
<table border="1"> <thead> <tr> <th style="background-color: #0070C0; color: white;">Code</th> <th style="background-color: #0070C0; color: white;">Contact Capacity</th> </tr> </thead> <tbody> <tr> <td style="text-align: center;"><b>SW</b></td> <td>AC125V 5A min. or AC250V 5A min. (Inductive load)</td> </tr> <tr> <td style="text-align: center;"><b>Ro, Co</b></td> <td>Ro=5~200 Co=0.1~0.2 , 200W (400W)</td> </tr> </tbody> </table>		Code	Contact Capacity	<b>SW</b>	AC125V 5A min. or AC250V 5A min. (Inductive load)	<b>Ro, Co</b>	Ro=5~200 Co=0.1~0.2 , 200W (400W)
Code	Contact Capacity						
<b>SW</b>	AC125V 5A min. or AC250V 5A min. (Inductive load)						
<b>Ro, Co</b>	Ro=5~200 Co=0.1~0.2 , 200W (400W)						
<p>* Connect a CR circuit for surge suppression to protect the contact.</p>							

- 1) The direction of motor rotation is as viewed from the shaft end of the motor.
- 2) CW represents the clockwise direction, while CCW represents the counterclockwise direction.
- 3) During operation it is available to change the rotating direction by turning the switch to CW or CCW.